

STATE OF SOUTH DAKOTA	PROJECT	SHEET NO.	TOTAL SHEETS
	P-PH 0028(36)355	S1	S22

Plotting Date: 08/13/2024

Revised 8/13/2024 AT

SECTION S: PERMANENT SIGN PLANS

INDEX OF SHEETS

- S1 General Layout with Index
- S2-S3 Estimate of Quantities and Notes
- S4 Delineation
- S5-S11 Permanent Sign Installation
- S12 Sign Summary
- S13-S14 Special Sign Design
- S15 Sign Installation Detail
- S16-S22 Standard Plates



BEGIN P-PH 0028(36)355
Station 11+11.77

END P-PH 0028(36)355
Station 568+41.79

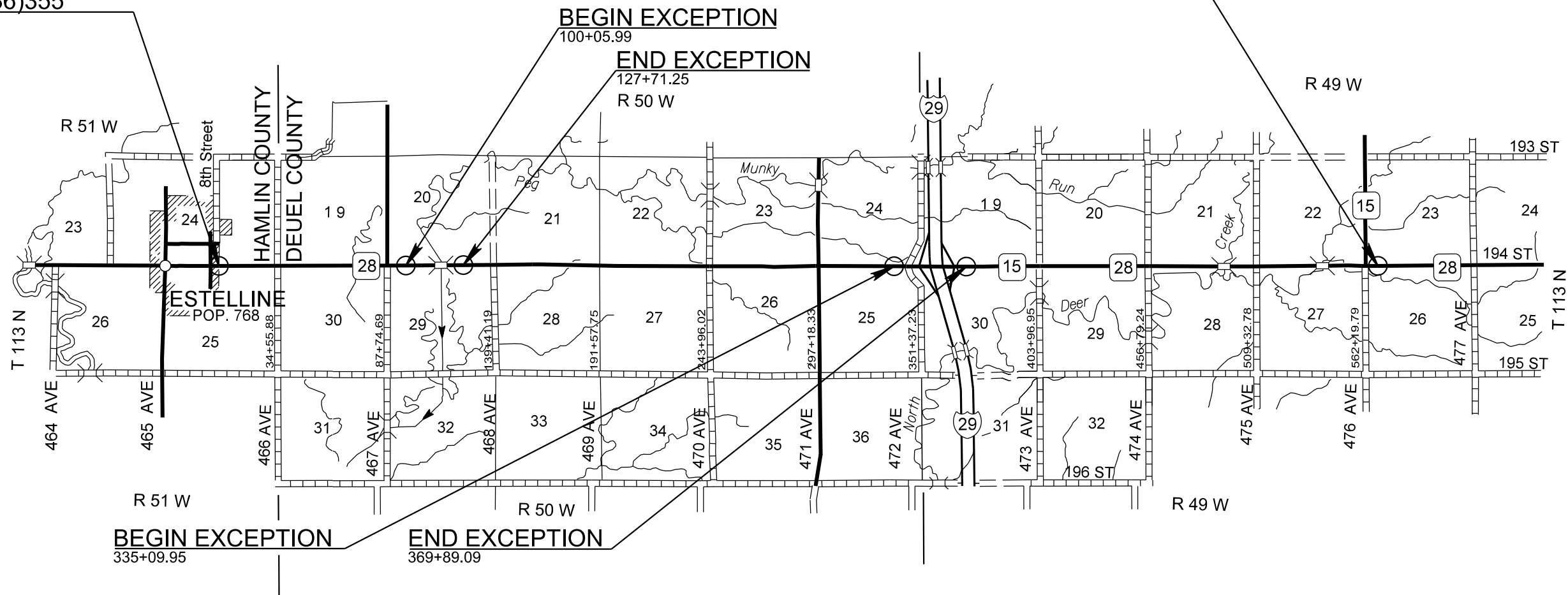

PLOT SCALE - 1:200

PLOTTED FROM - TRAB10100

PLOT NAME - 2

FILE - ... \SECTION S.DWG REVIEW\TITLES.DWG

SECTION S – ESTIMATE OF QUANTITIES – PCN 04HM

BID ITEM NUMBER	ITEM	QUANTITY	UNIT
110E0100	Remove Concrete Footing(s)	Lump Sum	LS
110E0130	Remove Traffic Sign	91	Each
110E0135	Remove Delineator	87	Each
110E5020	Salvage Traffic Sign	28	Each
110E7150	Remove Sign for Reset	30	Each
632E1320	2.0"x2.0" Perforated Tube Post	706.5	Ft
632E1340	2.5"x2.5" Perforated Tube Post	115.0	Ft
632E2022	4"x4" White Delineator Back to Back with 1.12 Lb/Ft Post	73	Each
632E2028	4" Tubular White Delineator with 1.12 Lb/Ft Post	6	Each
632E2510	Type 2 Object Marker Back to Back	155	Each
632E3203	Flat Aluminum Sign, Nonremovable Copy High Intensity	582.3	SqFt
632E3205	Flat Aluminum Sign, Nonremovable Copy Super/Very High Intensity	104.4	SqFt
632E3500	Reset Sign	29	Each

GENERAL PERMANENT SIGNING

New sign installations will be staked in the field by the Contractor and checked by the Engineer. The Contractor will give the Engineer a minimum of one week to check staked locations prior to signpost installation. Lateral offset of signs will be as shown in the plans or as directed by the Engineer.

The Contractor will be responsible for contacting South Dakota One Call to locate the utilities at the staked sign installation locations.

When signs are mounted in an assembly, they will be 1-2 inches apart vertically and horizontally.

The height of the post must not exceed the minimum height needed by more than 0.5 feet. Any portion that extends above the sign will be cut off. No separate payment will be made for cutting the post or for that length cut off.

Aluminum U-Channel stiffeners will be used on all signs 36 inches or greater in width and will conform to ASTM B221 Alloy 6063-T6 or 6061-T6. The U-Channel will be 2 inches in width and free of holes. The U-Channel stiffeners will also be used to connect various signs together so that an entire sign assembly can be erected on a single installation. Stiffeners may be fastened to signs by use of 1/4-inch diameter drive rivets.

The Contractor will use 3/8-inch diameter rust proof machine sign bolts, flat metal washers, neoprene washers (against the sign sheeting), lock washers, and nuts to fasten the sign to the channel aluminum and posts. A minimum of two bolts will extend through each post.

Prior to ordering signs, the Contractor will verify dimensions, background, border, and legend of the signs.

Prior to use, the Contractor will provide documentation for the sign support devices showing they meet the applicable NCHRP 350 or MASH requirements.

REMOVE TRAFFIC SIGN

Existing signs that are shown as being removed in the Permanent Signing Table will become the property of the Contractor. Existing signposts and

bases will be removed in their entirety. All existing signs, posts, and/or hardware removed will not be reused. Holes remaining from the removal of wood posts will be backfilled and compacted with material placed in layers not to exceed 6 inches in depth.

All costs associated with the removal of existing signs, posts, hardware, and backfilled holes will be incidental to the contract unit price per each for "Remove Traffic Sign". Quantities will be per assembly at the contract unit price per each.

NEW PERMANENT SIGNING

All signs will be manufactured in accordance with the sheeting manufacturer's recommendations utilizing a matched component system, including inks, electronic cuttable films, and protective overlay films.

All Flat Aluminum Signs, Nonremovable Copy High Intensity will have sheeting in conformance with the requirements of ASTM D4956 Type IV. All Flat Aluminum Signs, Nonremovable Copy Super/Very High Intensity will have sheeting in conformance with the requirements of ASTM D4956 Type XI.

All costs associated with furnishing and installing the new permanent signs, and with furnishing and installing stiffeners and hardware will be incidental to the contract unit price per square foot for "Flat Aluminum Sign, Nonremovable Copy High Intensity" or "Flat Aluminum Sign, Nonremovable Copy Super/Very High Intensity".

SALVAGE TRAFFIC SIGN

All Road Narrows, Shoulder Drop Off and No Passing Zone signs listed for salvage will have the existing posts, bases, and signs dismantled and delivered to the Clear Lake Maintenance Yard. The Contractor will notify the Engineer two days prior to time of delivery to the Maintenance Yard so correct placement for storage and inventory of materials can be made upon receipt. All bolts, nuts, and washers will be placed in individual 5-gallon pails. All signs listed for salvage will be handled with care so that the signs are not damaged during removal or transport. The Contractor will replace and pay for any salvaged signs damaged in their care.

All costs for labor and equipment necessary to remove, dismantle, and deliver signs to the Clear Lake Maintenance Yard will be incidental to the contract unit price for "Remove Traffic Sign".

REMOVE SIGN FOR RESET AND RESET SIGN

Signs that are scheduled for reset will be dismantled and reassembled to the extent needed by the Contractor to properly reset the sign. Signs will be handled with care so that the existing signs, posts, and bases are not damaged during the relocation process. The Contractor will replace and pay for any reset signs damaged in their care. The Contractor will remove and dispose of any existing posts for all reset signs that require use of new posts as shown in the Table of Permanent Signing.

All costs for removing, dismantling, and disposing of any existing posts will be incidental to the contract unit price per each for "Remove Sign for Reset".

All costs for resetting the existing signs will be incidental to the contract unit price per each for "Reset Sign". All quantities for Remove Sign for Reset and Reset Sign will be per assembly at the contract unit price per each.

STATE OF SOUTH DAKOTA	PROJECT	SHEET	TOTAL SHEETS
	P-PH 0028(36)355	S2	S22

Revised 8/13/2024 AT

Any 911 Emergency Number signs within the project work limits will not be stockpiled but temporarily repositioned at a location outside the work limits but within the immediate proximity of the existing location. To complete the project sign work, the 911 Emergency Number signs will be permanently installed at their original locations, or as near as practicable where entrances have been reconfigured by the project. The existing supports will be reused. Cost for removing, temporarily repositioning, and permanently resetting 911 Emergency Number signs will be included in the contract unit price per each for "Remove Sign for Reset" and "Reset Sign".

DIGITALLY PRINTED SIGNS

Digitally printed signs will be allowed on this project. If the Contractor elects to provide digitally printed signs, such signs will adhere to the following specifications.

PROTECTIVE OVERLAY FILM

Permanent traffic signs printed with digital ink systems will be fabricated with a full sign protective overlay film designed to provide a smooth surface needed for retroreflectivity, and to protect the sign from fading and UV degradation. The overlamine will comply with the retroreflective sheeting manufacturer's recommendations to ensure proper adhesion and transparency and will also meet the reflective film durability as identified in Table 1.

Table 1: Retroreflective Film Minimum Durability Requirements

ASTM D4956 Type	Full Sign Replacement Term (years)	Sheeting Replacement Term (years)
I	0	7
III	7	10
IV	7	10
VIII	7	10
IX	7	12
XI	7	12

FABRICATION

Retroreflective sheeting will be applied to a properly cleaned and prepared aluminum sign blank in accordance with the retroreflective sheeting manufacturer's recommendations. Sign legend will be applied using digital print technologies and systems in accordance with the retroreflective sheeting manufacturer's recommendations and the requirements of these plans.

Finished signs will be free of ragged edges and must be supplied clean and free of scratches, grease, oil, lubricants or other contaminants. Minor blemishes (dirt speck, dust, etc.) may settle on the fresh ink surface or become entrapped between the sheeting surface and transparent overlay film due to static charge within the sign shop environment. Any blemish must be minor and not interfere with the communication of the sign message to the motorist. The blemish must not be visible to the naked eye when viewed from 30 feet or greater.

STATE OF SOUTH DAKOTA	PROJECT	SHEET	TOTAL SHEETS
	P-PH 0028(36)355	S3	S22

Revised 8/13/2024 AT

DIGITALLY PRINTED SIGNS (CONTINUED)

After application of the retroreflective sheeting, sign blanks will be stacked and packaged face to face, back to back, and protected in accordance with the sheeting manufacturer's recommendations. Finished signs will be securely packaged to prevent damage during transit or storage according to the sheeting manufacturer's recommendations.

TRAFFIC SIGN PERFORMANCE WARRANTY PROVISIONS

Based on the ASTM Type of sheeting specified, traffic control signs will be warranted for the duration shown in Table 1. Full product terms and conditions are as established by each sheeting manufacturer and may contain certain limitations based on sheeting and ink colors, and geographic exposure of the sign. A copy of the warranty document with complete details of terms and conditions will be supplied if requested by the Engineer.

CERTIFIED DIGITAL SIGN FABRICATOR

Sign fabricators using digital imaging methods to produce regulated traffic signs must be certified by the reflective sheeting manufacturer whose materials are used to produce the delivered signs.

DATE TAGGING SIGNS WITH PERTINENT INFORMATION

All digitally printed signs are required to be date-tagged with the following 2 components:

1. Date tags on the back of signs
Tags will have the following information and be fabricated with material and printing system that are as durable as the warranted sign.
 - Name of Sign Fabricator
 - Date the sign was fabricated (month and year)
 - Process that was used for sign fabrication (digitally printed)
 - Supplier of sheeting that was used for fabricating the sign.
2. Border date
The month and year (mm/yyyy) of sign fabrication will be printed in the border of the sign in 3/8" sans serif font. Border date will be printed with the same warranted printed system as the sign face. The date should be printed in the locations indicated below.

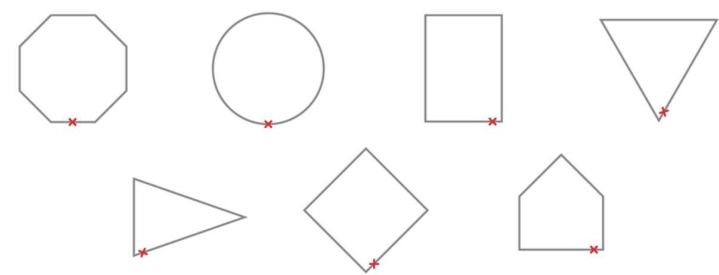

SQUARE TUBE ANCHOR SLEEVE

The Contractor will furnish and install new 2.5" x 2.5" x 18", 12 Gauge square tube anchor sleeve or equivalent components as approved by the Engineer for 2.0" x 2.0" perforated tube posts. A 2.25" x 2.25" x 4', 12 Gauge perforated tube post will be used as the anchor post for installation with the square tube anchor sleeve.

SQUARE TUBE POST SLEEVE

All 2.5" x 2.5", 10 Gauge perforated tube post will be sleeved with a 2-3/16" x 2-3/16" x 4', 10 Gauge perforated tube post.

WINGED SLIP BASE ANCHOR

The Contractor will furnish and install new winged slip base anchors for 2.5" x 2.5" perforated tube posts as required in the Permanent Signing Table. Winged slip base anchors will be installed using the direct drive method. Winged slip base anchors will consist of a slip base (upper), a 48-inch long winged anchor (lower), and a hardware kit.

TYPE 2 OBJECT MARKERS

All costs associated with the removal of object markers including posts and hardware and the installation of the new back-to-back object markers will be incidental to the contract unit price per each for "type 2 object marker back-to-back".

REMOVE CONCRETE FOOTING

Concrete footings that are to be removed will be removed by the Contractor to a minimum of 2' below the ground surface. Restoration of the disturbed area will be to the satisfaction of the Engineer.

The existing footings located at Stations 348+96 and 350+49 will be removed by the Contractor as per these plans.

All costs for removing the concrete footings will be incidental to the contract lump sum price for "Remove Concrete Footing(s)".

MILEAGE REFERENCE MARKERS

SDDOT will be notified to do Mileage Reference Markers (MRMs) locates prior to project completion by calling the Aberdeen Region Traffic Engineer at (605)626-2245. Payment for this work will be incidental to the various signing contract items.

NO PASSING ZONE SIGNS

SDDOT will be notified to do NO PASSING ZONE sign locates prior to project completion by calling the Aberdeen Region Traffic at (605)626-2245. Payment for this work will be incidental to the various signing contract items.

ROAD NARROWS SIGNS

Any Road Narrows signs will be returned to the SDDOT at the Clear Lake Maintenance Shop. The Engineer will be contacted before delivery. Cost for removing and returning the Road Narrows signs will be incidental to various contract items.

SIGNS FOR DELIVERY TO DOT

Any signs in the Permanent Sign Installation Table indicating "Deliver to DOT" will be returned to the SDDOT at the Clear Lake Maintenance Shop. The Engineer will be contacted before delivery. Cost for removing and returning the signs indicating "Deliver to DOT" will be incidental to various contract items.

DELINEATION

Delineation installation and spacing will be done according to Standard Plates 632.42, 632.44, and 632.46. Per the discretion of the Engineer, 73 delineators will be installed starting at Station 369+89 to Station 561+80. 3 delineators will be installed at the Northwest and Northeast radius of SD 15 respectively, totaling 6.

PLOT SCALE - 1:227.601

Object Marker Table		
Station	Type 2 Object Marker Back-to-Back (Each)	Description
15+91	2	1 Each Side of Road
22+54	2	1 Each Side of Road
25+82	1	1 Right Side of Road
26+38	1	1 Right Side of Road
28+34	1	1 Right Side of Road
28+84	1	1 Right Side of Road
35+19	2	1 Each Side of Road
40+05	1	1 Right Side of Road
40+71	1	1 Right Side of Road
57+39	1	1 Left Side of Road
57+89	1	1 Left Side of Road
64+54	2	1 Each Side of Road
73+04	2	1 Each Side of Road
88+35	2	1 Each Side of Road
97+25	2	1 Each Side of Road
127+94.19	1	1 Left Side of Road
128+13	1	1 Right Side of Road
128+54.31	1	1 Left Side of Road
128+79	1	1 Right Side of Road
133+95	2	1 Each Side of Road
139+06	1	1 Left Side of Road
139+06	1	1 Right Side of Road
139+76	1	1 Left Side of Road
139+76	1	1 Right Side of Road
145+00	2	1 Each Side of Road
148+34	2	1 Each Side of Road
154+22	2	1 Each Side of Road
159+15	2	1 Each Side of Road
162+06	1	1 Left Side of Road
162+88	1	1 Left Side of Road
167+69	2	1 Each Side of Road
170+56	2	1 Each Side of Road
177+94	2	1 Each Side of Road
191+23	1	1 Left Side of Road
191+93	1	1 Left Side of Road
193+51	1	1 Left Side of Road
194+17	1	1 Left Side of Road
202+29	2	1 Each Side of Road
203+86	1	1 Left Side of Road
204+88	1	1 Left Side of Road

Object Marker Table		
Station	Type 2 Object Marker Back-to-Back (Each)	Description
215+28	2	1 Each Side of Road
221+95	2	1 Each Side of Road
229+50	2	1 Each Side of Road
230+45	1	1 Left Side of Road
231+27	1	1 Left Side of Road
240+95	2	1 Each Side of Road
245+22	1	1 Left Side of Road
245+39	1	1 Left Side of Road
245+70	1	1 Right Side of Road
245+86	1	1 Right Side of Road
255+95	1	1 Left Side of Road
265+16	2	1 Each Side of Road
256+61	1	1 Left Side of Road
272+60	2	1 Each Side of Road
290+07	2	1 Each Side of Road
296+83	1	1 Left Side of Road
296+83	1	1 Right Side of Road
297+53	1	1 Left Side of Road
297+53	1	1 Right Side of Road
323+82	1	1 Left Side of Road
334+35	2	1 Each Side of Road
324+62	1	1 Left Side of Road
371+35	1	1 Left Side of Road
371+97	1	1 Left Side of Road
373+47	1	1 Left Side of Road
374+11	1	1 Left Side of Road
377+09	1	1 Right Side of Road
377+27	1	1 Left Side of Road
377+75	1	1 Right Side of Road
377+93	1	1 Left Side of Road
404+56	2	1 Each Side of Road
408+77	1	1 Right Side of Road
409+43	1	1 Right Side of Road
416+74	1	1 Left Side of Road
417+52	1	1 Left Side of Road
423+54	2	1 Each Side of Road
442+45	2	1 Each Side of Road
452+84	1	1 Left Side of Road
453+34	1	1 Left Side of Road
456+35	1	1 Right Side of Road

Object Marker Table		
Station	Type 2 Object Marker Back-to-Back (Each)	Description
456+40	1	1 Left Side of Road
457+23	1	1 Right Side of Road
457+39	1	1 Left Side of Road
458+50	1	1 Right Side of Road
460+25	2	1 Each Side of Road
460+50	1	1 Right Side of Road
462+50	1	1 Right Side of Road
464+50	1	1 Right Side of Road
466+50	1	1 Right Side of Road
468+50	1	1 Right Side of Road
469+03	2	1 Each Side of Road
469+07	1	1 Left Side of Road
470+39	1	1 Left Side of Road
470+50	1	1 Right Side of Road
482+56	1	1 Left Side of Road
483+36	1	1 Left Side of Road
493+40	1	1 Left Side of Road
493+50	2	1 Each Side of Road
493+60	1	1 Right Side of Road
505+60	2	1 Each Side of Road
508+89	1	1 Left Side of Road
509+64	1	1 Left Side of Road
512+75	2	1 Each Side of Road
523+27	2	1 Each Side of Road
542+89	2	1 Each Side of Road
543+11	2	1 Each Side of Road
544+40	1	1 Right Side of Road
545+06	1	1 Right Side of Road
550+61	1	1 Right Side of Road
551+27	1	1 Right Side of Road
554+14	1	1 Left Side of Road
554+30	1	1 Left Side of Road
554+46	1	1 Right Side of Road
554+54	1	1 Right Side of Road
561+85	1	1 Right Side of Road
562+55	1	1 Right Side of Road
564+17	2	1 Each Side of Road
564+59	1	1 Left Side of Road
565+17	1	1 Left Side of Road
Total	155	

PLOTTED FROM - TRAB10100

PLOT NAME - 1

FILE - ... \BROK05EX\SECTION SAT.TITLES.DGN

SD 28 Permanent Sign Installation Table

Station	Side of Road	Description	Sign Code	Width (Inches)	Height (Inches)	Flat Aluminum sign, Nonremovable Copy High Intensity (SQFT)	Flat Aluminum Sign, Nonremovable Copy Super/Very High Intensity (SQFT)	2.0"x2.0" Perforated Tube Post 12 ga. (FT)	2.5"x2.5" Perforated Tube Post 10 Ga. (FT)	(N.A.B.I.) Square Tube Anchor Sleeve (Each)	(N.A.B.I.) 48" Winged Slip Base Anchor (Each)	Remove Traffic Sign (Each)	Remove Sign For Reset (Each)	Reset Sign (Each)	Salvage Traffic Sign (Each)	Direction Sign Faces	Current Type of Post	Remarks
13+90	Lt.	Estelline POP 749	D1-1	60	18	7.5		24.0		2		1				E	Telespar	Replace Existing Sign with New Sign on Existing Post
16+05	Rt.	No Passing Zone	W14-3	48X48X36								1			1	E	Telespar	Remove Existing Sign Deliver to DOT.
23+29	Rt.	Speed Limit 65	R2-1	24	30			11.0		1			1	1		W	Telespar	Remove and Reset Existing Sign on New Post
23+29	Lt.	Speed Limit 45	R2-1	24	30			11.0		1			1	1		E	Telespar	Remove and Reset Existing Sign on New Post
29+48	Lt.	Speed Reduction 45 MPH	W3-5	36	36			11.5		1			1	1		E	Telespar	Remove and Reset Existing Sign on New Post
31+88	Lt.	DYNAMIC ENGINE BRAKING PROHIBITED		30	36							1				E	Telespar	Remove Existing Signs
		By City Ordinance		30	12													Place New Sign on New Post
31+88	Lt.	UNMUFFLED DYNAMIC ENGINE BRAKING PROHIBITED By City Ordinance		30	36	7.5		11.0		1								Place New Sign on New Post
33+94	Lt.	HAMLIN COUNTY	I-1	30	24			11.0		1			1	1		E	Telespar	Remove and Reset Existing Sign on New Post
34+34	Lt.	Stop	R1-1	30	30			11.0		1			1	1		N	Telespar	Remove and Reset Existing Sign on New Post
34+76	Rt.	Stop	R1-1	30	30			11.0		1			1	1		S	Telespar	Remove and Reset Existing Sign on New Post
34+89	Lt.	466 Ave (Two Signs)	D3-1	36	12	6.0		12.0		1		1				E/W	Telespar	Place New Sign on New Post
		SD Hwy 28 (Two Signs)	D3-1	42	12	7.0								N/S				
35+45	Rt.	DEUEL COUNTY	I-1	30	24			11.0		1			1	1		W	Telespar	Remove and Reset Existing Sign on New Post
		SHOULDER DROP OFF	W8-17P	36	36							1		1	Remove Existing Sign Deliver to DOT.			
59+87	Rt.	Mile Marker 356 (Two Signs)	D10-6	4.5	18	1.1		5.0		1		1			E/W	Telespar	Replace Existing Sign with New Sign on New Post at Existing MRM Location	
59+87	Lt.	Adopt A Highway	ADO-5	36	36							1				E	Telespar	Remove Existing Signs
		Trinity Lutheran Church ESTELLINE	ADO-1	36	18													
		Litter Crew Ahead	ADO-6	30	30													
87+48	Lt.	Stop	R1-1	30	30			11.0		1			1	1		N	Telespar	Remove and Reset Existing Sign on New Post
87+94	Rt.	Stop	R1-1	30	30			11.0		1			1	1		S	Telespar	Remove and Reset Existing Sign on New Post
88+20	Lt.	467 Ave (Two Signs)	D3-1	36	12	6.0		12.0		1		1				E/W	Telespar	Replace Existing Sign with New Sign on New Post
		SD Hwy 28 (Two Signs)	D3-1	42	12	7.0								N/S				
114+08	Rt.	Mile Marker 357 (Two Signs)	D10-6	4.5	18	1.1		5.0		1		1			E/W	Telespar	Replace Existing Sign with New Sign on New Post at Existing MRM Location	
114+11	Lt.	Mile Marker 357.02 (Two Signs)	D10-6	4.5	21	1.3		5.0		1		1			E/W	Telespar	Replace Existing Sign with New Sign on New Post at Existing MRM Location	
129+59	Lt.	No Passing Zone	W14-3	48X48X36								1			1	W	Telespar	Remove Existing Sign Deliver to DOT.
139+24	Lt.	Stop	R1-1	30	30			11.0		1			1	1		N	Telespar	Remove and Reset Existing Sign on New Post
139+60	Rt.	Stop	R1-1	30	30			11.0		1			1	1		S	Telespar	Remove and Reset Existing Sign on New Post
139+72	Lt.	468 Ave (Two Signs)	D3-1	36	12	6.0		12.0		1		1				E/W	Telespar	Replace Existing Sign with New Sign on New Post
		SD Hwy 28 (Two Signs)	D3-1	42	12	7.0								N/S				
148+15	Rt.	ADVANCE TRUCK (SYM)	W11-10	48	48							1			1	W	Telespar	Remove Existing Sign Deliver to DOT.
		TRUCKS ENTERING HIGHWAY	W8-6G	42	36													
149+30	Rt.	No Passing Zone	W14-3	48X48X36								1			1	E	Telespar	Remove Existing Sign Deliver to DOT.
151+19	Lt.	No Passing Zone	W14-3	48X48X36								1			1	W	Telespar	Remove Existing Sign Deliver to DOT.
166+52	Rt.	Mile Marker 358 (Two Signs)	D10-6	4.5	18	1.1		5.0		1		1			E/W	U Channel	Replace Existing Sign with New Sign on New Post at Existing MRM Location	

SD 28 Permanent Sign Installation Table

Station	Side of Road	Description	Sign Code	Width (Inches)	Height (Inches)	Flat Aluminum sign, Nonremovable Copy High Intensity (SQFT)	Flat Aluminum Sign, Nonremovable Copy Super/Very High Intensity (SQFT)	2.0"x2.0" Perforated Tube Post 12 ga. (FT)	2.5"x2.5" Perforated Tube Post 10 Ga. (FT)	(N.A.B.I.) Square Tube Anchor Sleeve (Each)	(N.A.B.I.) 48" Winged Slip Base Anchor (Each)	Remove Traffic Sign (Each)	Remove Sign For Reset (Each)	Reset Sign (Each)	Salvage Traffic Sign (Each)	Direction Sign Faces	Current Type of Post	Remarks
172+37	Rt.	No Passing Zone	W14-3	48X48X36								1			1	E	Telespar	Remove Existing Sign Deliver to DOT.
175+59	Lt.	ADVANCE TRUCK (SYM)	W11-10	48	48							1			1	E	Telespar	Remove Existing Sign Deliver to DOT.
		TRUCKS ENTERING HIGHWAY	W8-6G	42	36													
182+08	Lt.	No Passing Zone	W14-3	48X48X36								1			1	W	Telespar	Remove Existing Sign Deliver to DOT.
199+84	Lt.	No Passing Zone	W14-3	48X48X36								1			1	W	Telespar	Remove Existing Sign Deliver to DOT.
203+11	Rt.	No Passing Zone	W14-3	48X48X36								1			1	E	Telespar	Remove Existing Sign Deliver to DOT.
218+18	Rt.	No Passing Zone	W14-3	48X48X36								1			1	E	Telespar	Remove Existing Sign Deliver to DOT.
218+89	Rt.	Mile Marker 359 (Two Signs)	D10-6	4.5	18	1.1		5.0		1		1				E/W	U Channel	Replace Existing Sign with New Sign on New Post at Existing MRM Location
220+66	Lt.	No Passing Zone	W14-3	48X48X36								1			1	W	Telespar	Remove Existing Sign Deliver to DOT.
241+28	Rt.	No Passing Zone	W14-3	48X48X36								1			1	E	Telespar	Remove Existing Sign Deliver to DOT.
243+75	Lt.	Stop	R1-1	30	30			11.0		1			1	1		N	Telespar	Remove and Reset Existing Sign on New Post
244+15	Rt.	Stop	R1-1	30	30			11.0		1			1	1		S	Telespar	Remove and Reset Existing Sign on New Post
244+34	Lt.	470 Ave (Two Signs)	D3-1	36	12	6.0				1		1				E/W	Telespar	Replace Existing Sign with New Sign on New Post
		SD Hwy 28 (Two Signs)	D3-1	42	12	7.0		12.0								N/S		
245+24	Lt.	No Passing Zone	W14-3	48X48X36								1			1	W	Telespar	Remove Existing Sign Deliver to DOT.
245+23	Rt.	No Passing Zone	W14-3	48X48X36								1			1	E	Telespar	Remove Existing Sign Deliver to DOT.
272+03	Rt.	Mile Marker 360 (Two Signs)	D10-6	4.5	18	1.1		5.0		1		1				E/W	U Channel	Replace Existing Sign with New Sign on New Post at Existing MRM Location
295+14	Lt.	WEST	M3-4	24	12	2.0				1		1				E	Telespar	Replace Existing Signs with New Signs on New Post
		SD 28	M1-5	24	24	4.0		11.0										
296+75	Lt.	THINK SIGN WHY DIE?										1				E	U Channel	Remove Existing Sign
296+86	Lt.	Stop	R1-1	30	30		5.2	11.0		1		1				N	Telespar	Replace Existing Sign with New Sign on New Post
297+43	Rt.	Stop	R1-1	30	30		5.2	11.0		1		1				S	Telespar	Replace Existing Sign with New Sign on New Post
297+68	Lt.	471 Ave (Two Signs)	D3-1	36	12	6.0				1		1				E/W	Telespar	Replace Existing Sign with New Sign on New Post
		SD Hwy 28 (Two Signs)	D3-1	42	12	7.0		12.0								N/S		
324+63	Rt.	Mile Marker 361 (Two Signs)	D10-6	4.5	18	1.1		5.0		1		1				E/W	U Channel	Replace Existing Sign with New Sign on New Post at Existing MRM Location
335+88	Lt.	JUST A REMINDER SPEED LIMIT 65 PLEASE BUCKLE UP!	I-NS7									1				E	Telespar in Concrete	Remove Existing Signs and Posts
		IT'S THE LAW	R16-1															
337+93	Lt.	Speed Limit 65	R2-1	24	30	5.0		11.0		1		1				E	Telespar	Replace Existing Sign with New Sign on New Post
337+94	Rt.	JCT (blue)	M2-1	21	15	2.2				1		1				W	Telespar	Replace Existing Signs with New Signs on New Post
		I 29	M1-1	24	24	4.0		12.5										
340+64	Lt.	No Passing Zone	W14-3	48X48X36									1			W	Telespar	Remove and Reset Existing Sign at Station 341+50.
		SHOULDER DROP OFF	W8-17P	36	36								1		1			Remove Existing Sign Deliver to DOT.
341+50	Lt.	No Passing Zone	W14-3	48X48X36				11.0						1		W	Telespar	Reset Sign from Station 340+64 on New Post.
341+97	Lt.	Estelline 7 Hwy 81 20	D1-2	60	36	15.0						1				NE	Telespar	Replace Existing Sign with New Sign on Existing Post
342+94	Rt.	^ Toronto ^ Watertown Brookings -->	D1-2	108	60	45.0						1				W	Galvanized Steel Beam Breakaway	Replace Existing Sign with New Sign on Existing Post

SD 28 Permanent Sign Installation Table

Station	Side of Road	Description	Sign Code	Width (Inches)	Height (Inches)	Flat Aluminum sign, Nonremovable Copy High Intensity (SQFT)	Flat Aluminum Sign, Nonremovable Copy Super/Very High Intensity (SQFT)	2.0"x2.0" Perforated Tube Post 12 ga. (FT)	2.5"x2.5" Perforated Tube Post 10 Ga. (FT)	(N.A.B.I.) Square Tube Anchor Sleeve (Each)	(N.A.B.I.) 48" Winged Slip Base Anchor (Each)	Remove Traffic Sign (Each)	Remove Sign For Reset (Each)	Reset Sign (Each)	Salvage Traffic Sign (Each)	Direction Sign Faces	Current Type of Post	Remarks	
344+45	Lt.	Road Narrows	W5-1	36	36							1			1	E	Telespar	Remove Existing Sign Deliver to DOT.	
345+75	Lt.	Stop	R1-1	30	30		5.2	11.0		1		1				N	Telespar	Replace Existing Sign with New Sign on New Post	
346+13	Rt.	Stop	R1-1	30	30		5.2	11.0		1		1				S	Telespar	Replace Existing Sign with New Sign on New Post	
346+43	Lt.	472 Ave (Two Signs)	D3-1	36	12	6.0				1		1				E/W	Telespar	Replace Existing Signs with New Signs on New Posts	
		SD Hwy 28 (Two Signs)	D3-1	42	12	7.0		12.0								N/S			
346+94	Lt.	WEST	M3-4	24	12	2.0						1				E	Galvanized Pipe Breakaway	Replace Existing Signs with New Signs on Existing Post	
		SD 28	M1-5	24	24	4.0													
347+97	Rt.	EAST	M3-2	24	12	2.0											W	Galvanized Steel Beam Breakaway	Replace Existing Signs with New Signs on New Post
		SD 28	M1-5	24	24	4.0													
		Vertical Single Arrow	M6-3	21	15	2.2				26		2							
		South (blue)	M3-3	24	12	2.0													
		I 29	M1-1	24	24	4.0							1						
		Horizontal Arrow (blue)	M6-1	21	15	2.2													
		North	M3-1	24	12														
348+83	Lt.	ONE WAY ON LEFT ARROW	R6-1L	54	18	6.8						1				E	Perforated Tube Flush Mount (Bolted to Concrete)	Replace Existing Signs with New Signs on Existing Post	
		ONE WAY ON RIGHT ARROW	R6-1R	54	18	6.8									W				
		Stop	R1-1	36	36		7.7								N				
		DO NOT ENTER	R5-1	36	36		9.0								S				
348+87	Rt.	LODGING (SYM)	D9-9	24	24	4.0						1				N	Telespar	Replace Existing Signs with New Signs on Existing Post	
		GAS (SYM)	D9-7	24	24	4.0													
		7 MILES	SW3-1	36	12	3.0													
		Horizontal Arrow (blue)	M6-1	21	15	2.2													
348+96	Rt.	North	M3-1	24	12							1				N	Telespar in Concrete	Remove Existing Signs	
		SD 15	M1-5	24	24														
		Horizontal Arrow	M6-1	21	15														
		SD 28	M1-5	24	24	4.0													
349+59	Lt.	Horizontal Double Head Arrow	M6-4	21	15	2.2		11.0		1							Perforated Tube Flush Mount (Bolted to Concrete)	Replace Existing Signs with New Signs on New Post	
		ONE WAY ON LEFT ARROW	R6-1L	54	18	6.8						1			E				
		ONE WAY ON RIGHT ARROW	R6-1R	54	18	6.8									W				
		Stop	R1-1	36	36		7.7								N				
		DO NOT ENTER	R5-1	36	36		9.0								S				

SD 28 Permanent Sign Installation Table

Station	Side of Road	Description	Sign Code	Width (Inches)	Height (Inches)	Flat Aluminum sign, Nonremovable Copy High Intensity (SQFT)	Flat Aluminum Sign, Nonremovable Copy Super/Very High Intensity (SQFT)	2.0"x2.0" Perforated Tube Post 12 ga. (FT)	2.5"x2.5" Perforated Tube Post 10 Ga. (Ft)	(N.A.B.I.) Square Tube Anchor Sleeve (Each)	(N.A.B.I.) 48" Winged Slip Base Anchor (Each)	Remove Traffic Sign (Each)	Remove Sign For Reset (Each)	Reset Sign (Each)	Salvage Traffic Sign (Each)	Direction Sign Faces	Current Type of Post	Remarks
350+49	Lt.	South (blue)	M3-3	24	12	2.0			26.0		2	1				E	Galvanized Steel Beam Breakaway in Concrete	Replace Existing Sign with New Sign on New Post
		I 29	M1-1	24	24	4.0												
		Horizontal Arrow (blue)	M6-1	21	15	2.2												
		WEST	M3-4	24	12	2.0												
		SD 28	M1-5	24	24	4.0												
		Vertical Single Arrow	M6-3	21	15	2.2												
352+58	Rt.	^ Estelline ← Brookings	D1-2	66	30	13.8						1				E	Telespar	Replace Existing Sign with New Sign on Existing Post
356+10	Rt.	Mile Marker 361.61 (Two Signs)	D10-6	4.5	21	1.3		5.0		1		1				E/W	U Channel	Replace Existing Sign with New Sign on New Post at Existing MRM Location
356+13	Lt.	END MARKER	R3-9dP	18	12							1				E	Telespar	Remove Existing Signs and Post
		SD 15	M1-5	24	24													
356+46	Rt.	^ Toronto ← Watertown	D1-2	96	48	32.0						1				W	Galvanized Steel Beam Breakaway	Replace Existing Sign with New Sign on Existing Post
358+46	Rt.	North (blue)	M3-1	24	12	2.0			26		2	1				W	Galvanized Steel Beam Breakaway	Replace Existing Signs with New Signs on New Post
		I 29	M1-1	24	24	4.0												
		Horizontal Arrow (blue)	M6-1	21	15	2.2												
		EAST	M3-2	24	12	2.0												
				SD 28	M1-5	24	24	4.0										
				Vertical Single Arrow	M6-3	21	15	2.2										
				North	M3-1	24	12											
		SD 15	M1-5	24	24													
		Vertical Single Arrow	M6-3	21	15													
359+36	Rt.	ONE WAY ON LEFT ARROW	R6-1L	54	18	6.8						1				W	Telespar (Bolted to Concrete)	Replace Existing Signs with New Signs on Existing Post
		ONE WAY ON RIGHT ARROW	R6-1R	54	18	6.8												
		Stop	R1-1	36	36		7.7											
		DO NOT ENTER	R5-1	36	36		9.0											
359+91	Rt.	ONE WAY ON LEFT ARROW	R6-1L	54	18	6.8						1				W	Perforated Tube Flush Mount (Bolted to Concrete)	Replace Existing Signs with New Signs on Existing Post
		ONE WAY ON RIGHT ARROW	R6-1R	54	18	6.8												
		Stop	R1-1	36	36		7.7											
		DO NOT ENTER	R5-1	36	36		9.0											
359+99	Lt.	North	M3-1	24	12							1				S	Telespar	Remove Existing Signs
		SD 15	M1-5	24	24													
		Horizontal Arrow	M6-1	21	15													
		SD 28	M1-5	24	24	4.0												
		Horizontal Double Head Arrow	M6-4	21	15	2.2		11.0		1								Replace Existing Signs with New Signs on New Post
360+09	Lt.	LODGING (SYM)	D9-9	24	24	4.0						1				S	Telespar	Replace Existing Signs with New Signs on Existing Post
		GAS (SYM)	D9-7	24	24	4.0												
		7 MILES	SW3-1	36	12	3.0												
		Horizontal Arrow (blue)	M6-1	21	15	2.2												

SD 28 Permanent Sign Installation Table

Station	Side of Road	Description	Sign Code	Width (Inches)	Height (Inches)	Flat Aluminum sign, Nonremovable Copy High Intensity (SQFT)	Flat Aluminum Sign, Nonremovable Copy Super/Very High Intensity (SQFT)	2.0"x2.0" Perforated Tube Post 12 ga. (FT)	2.5"x2.5" Perforated Tube Post 10 Ga. (Ft)	(N.A.B.I.) Square Tube Anchor Sleeve (Each)	(N.A.B.I.) 48" Winged Slip Base Anchor (Each)	Remove Traffic Sign (Each)	Remove Sign For Reset (Each)	Reset Sign (Each)	Salvage Traffic Sign (Each)	Direction Sign Faces	Current Type of Post	Remarks
360+95	Rt.	DO NOT ENTER	R5-1	36	36		9.0					1				E	Galvanized Pipe Breakaway	Replace Existing Sign with New Sign on Existing Post
360+98	Lt.	South (blue)	M3-3	24	12	2.0						1				E	Galvanized Steel Beam Breakaway	Replace Existing Signs with New Signs on Existing Post
		I 29	M1-1	24	24	4.0												
		Vertical Single Arrow (blue)	M6-1	21	15	2.2												
		WEST	M3-4	24	12	2.0												
		SD 28	M1-5	24	24	4.0												
		Vertical Single Arrow	M6-3	21	15	2.2												
		North (blue)	M3-1	24	12	2.0												
		I 29	M1-1	24	24	4.0												
		Horizontal Arrow (blue)	M6-1	21	15	2.2												
361+44	Rt.	YIELD	R1-2	36	36		7.8					1				SW	Galvanized Steel Beam Breakaway	Replace Existing Sign with New Sign on Existing Post
363+95	Rt.	EAST	M3-2	24	12	2.0						1				W	Telespar	Replace Existing Signs with New Signs on Existing Post and Retrofit for Single Assembly
		SD 28	M1-5	24	24	4.0					Remove Existing Signs							
		North	M3-1	24	12													
		SD 15	M1-5	24	24													
365+45	Rt.	Road Narrows	W5-1	36	36							1		1	W	Telespar	Remove Existing Sign Deliver to DOT.	
365+96	Lt.	^ Estelline ^ Brookings Watertown -->	D1-2	108	60	45.0						1			E	Galvanized Steel Beam Breakaway	Replace Existing Sign with New Sign on Existing Post and Extruded Aluminum	
366+00	Rt.	No Passing Zone	W14-3	48X48X36				11.0		1				1	E	Telespar	Reset Sign from Station 366+83 on New Post	
366+83	Rt.	No Passing Zone	W14-3	48X48X36									1		E	Telespar	Remove and Reset Existing Sign at Station 366+00.	
368+94	Rt.	Toronto 6 Clear Lake 15	D1-2	96	36	24.0						1			W	Galvanized Pipe Breakaway	Replace Existing Sign with New Sign on Existing Post and Extruded Aluminum	
370+91	Lt.	JCT (blue)	M2-1	21	15	2.2						1			E	Telespar	Replace Existing Sign with New Signs on New Post	
		I 29	M1-1	24	24	4.0		11.5		1								
371+81	Rt.	Speed Limit 65	R2-1	24	30	5.0		11.0		1		1			W	Telespar	Replace Existing Sign with New Sign on New Post	
		SHOULDER DROP OFF	W8-17P	36	36								1	Remove Existing Sign Deliver to DOT.				
373+76	Rt.	JUST A REMINDER SPEED LIMIT 65 PLEASE BUCKLE UP!	I-NS7									1			W	Telespar	Remove Existing Signs	
		IT'S THE LAW	R16-1															
376+93	Rt.	Mile Marker 362 (Two Signs)	D10-6	4.5	18	1.1		5.0		1		1			E/W	U Channel	Replace Existing Sign with New Sign on New Post at Existing MRM Location	
403+75	Lt.	Stop	R1-1	30	30			11.0		1		1	1		N	Telespar	Remove and Reset Existing Sign on New Post	
404+15	Rt.	Stop	R1-1	30	30			11.0		1		1	1		S	Telespar	Remove and Reset Existing Sign on New Post	
404+34	Lt.	473 Ave (Two Signs)	D3-1	36	12	6.0						1			E/W N/S	Telespar	Replace Existing Signs with New Signs on New Post	
		SD Hwy 28 (Two Signs)	D3-1	42	12	7.0		11.0		1								
405+69	Rt.	EAST	M3-2	24	12			11.0		1		1	1	W	Telespar	Remove and Reset Existing Sign on New Post		
		SD 28	M1-5	24	24													
423+87	Lt.	No Passing Zone	W14-3	48X48X36								1			1	W	Telespar	Remove Existing Sign Deliver to DOT.

SD 28 Permanent Sign Installation Table

Station	Side of Road	Description	Sign Code	Width (Inches)	Height (Inches)	Flat Aluminum sign, Nonremovable Copy High Intensity (SQFT)	Flat Aluminum Sign, Nonremovable Copy Super/Very High Intensity (SQFT)	2.0"x2.0" Perforated Tube Post 12 ga. (FT)	2.5"x2.5" Perforated Tube Post 10 Ga. (Ft)	(N.A.B.I.) Square Tube Anchor Sleeve (Each)	(N.A.B.I.) 48" Winged Slip Base Anchor (Each)	Remove Traffic Sign (Each)	Remove Sign For Reset (Each)	Reset Sign (Each)	Salvage Traffic Sign (Each)	Direction Sign Faces	Current Type of Post	Remarks											
429+22	Rt.	Mile Marker 363 (Two Signs)	D10-6	4.5	18	1.1		5.0		1		1				E/W	U Channel	Replace Existing Sign with New Sign on New Post at Existing MRM Location											
440+61	Lt.	No Passing Zone	W14-3	48X48X36								1			1	W	Telespar	Remove Existing Sign Deliver to DOT.											
443+24	Rt.	No Passing Zone	W14-3	48X48X36								1			1	E	Telespar	Remove Existing Sign Deliver to DOT.											
456+56	Lt.	Stop	R1-1	30	30			11.0		1			1	1		N	Telespar	Remove and Reset Existing Sign on New Post											
456+97	Rt.	Stop	R1-1	30	30			11.0		1			1	1		S	Telespar	Remove and Reset Existing Sign on New Post											
457+10	Lt.	474 Ave (Two Signs)	D3-1	36	12	6.0		11.0		1		1				E/W	Telespar	Replace Existing Signs with New Signs on New Post											
		SD Hwy 28 (Two Signs)	D3-1	42	12	7.0	N/S																						
461+97	Rt.	No Passing Zone	W14-3	48X48X36								1			1	E	Telespar	Remove Existing Sign Deliver to DOT.											
480+92	Rt.	Mile Marker 364 (Two Signs)	D10-6	4.5	18	1.1		5.0		1		1				E/W	U Channel	Replace Existing Sign with New Sign on New Post at Existing MRM Location											
493+65	Rt.	Mile Marker 364.22 (Two Signs)	D10-6	4.5	21	1.3		5.0		1		1				E/W	U Channel	Replace Existing Sign with New Sign on New Post at Existing MRM Location											
503+00	Lt.	No Passing Zone	W14-3	48X48X36								1			1	W	Telespar	Remove Existing Sign Deliver to DOT.											
509+09	Lt.	Stop	R1-1	30	30			10.5		1			1	1		N	Telespar	Remove and Reset Existing Sign on New Post											
509+47	Rt.	Stop	R1-1	30	30			10.5		1			1	1		S	Telespar	Remove and Reset Existing Sign on New Post											
509+59	Lt.	475 Ave (Two Signs)	D3-1	36	12	6.0		11.0		1		1				E/W	Telespar	Replace Existing Signs with New Signs on New Post											
		SD Hwy 28 (Two Signs)	D3-1	42	12	7.0	N/S																						
522+54	Rt.	No Passing Zone	W14-3	48X48X36								1			1	E	Telespar	Remove Existing Sign Deliver to DOT.											
529+83	Rt.	Mile Marker 365 (Two Signs)	D10-6	4.5	18	1.1		5.0		1		1				E/W	U Channel	Replace Existing Sign with New Sign on New Post at Existing MRM Location											
543+19	Rt.	Mile Marker 365.16 (Two Signs)	D10-6	4.5	21	1.3		5.0		1		1				E/W	U Channel	Replace Existing Sign with New Sign on New Post at Existing MRM Location											
543+71	Lt.	No Passing Zone	W14-3	48X48X36								1			1	W	Telespar	Remove Existing Sign Deliver to DOT.											
552+12	Rt.	SD 15	M1-5	24	24													Remove Existing Sign											
		Advance Left Turn Arrow	M5-1L	21	15							1					W												
		SD 28	M1-5	24	24																								
		Vertical Single Arrow	M6-3	21	15																								
555+00	Rt.	JCT	M2-1	21	15	2.2		11.0		1								Place New Signs on New Post											
		SD 15	M1-5	24	24	4.0																							
557+13	Rt.	^ Toronto 2 ← Clear Lake 12	D1-2	96	30				24.0		2		1	1		W	Telespar	Remove and Reset Existing Sign on New Post											
559+18	Lt.	WEST	M3-4	24	12			24.0		2			1	1		E	Telespar	Remove and Reset Existing Sign on New Post											
		SD 28	M1-5	24	24														1		1								
		SHOULDER DROP OFF	W8-17P	36	36																1		1						
561+80	Lt.	Stop	R1-1	30	30			10.5		1			1	1		N	Telespar	Remove and Reset Existing Sign on New Post											
561+87	Rt.	North	M3-1	24	12	2.0		24.0		2						W	Telespar	Place New Sign											
		SD 15	M1-5	24	24																						Remove and Reset Existing Sign on New Post		
		Horizontal Arrow	W1-7	21	15																							Place New Sign	
		EAST	M3-2	24	12	2.0																							Remove and Reset Existing Sign on New Post
		SD 28	M1-5	24	24																								
		Vertical Single Arrow	M6-3	21	15																								Remove and Reset Existing Sign on New Post

SD 28 Permanent Sign Installation Table

Station	Side of Road	Description	Sign Code	Width (Inches)	Height (Inches)	Flat Aluminum sign, Nonremovable Copy High Intensity (SQFT)	Flat Aluminum Sign, Nonremovable Copy Super/Very High Intensity (SQFT)	2.0"x2.0" Perforated Tube Post 12 ga. (FT)	2.5"x2.5" Perforated Tube Post 10 Ga. (Ft)	(N.A.B.I.) Square Tube Anchor Sleeve (Each)	(N.A.B.I.) 48" Winged Slip Base Anchor (Each)	Remove Traffic Sign (Each)	Remove Sign For Reset (Each)	Reset Sign (Each)	Salvage Traffic Sign (Each)	Direction Sign Faces	Current Type of Post	Remarks											
561+84		END MARKER	R3-9dP	18	12	1.5		11.0		1						N		Place New Sign on New Post											
		SD 15	M1-5	24	24	4.0																							
562+36	Rt.	Stop	R1-1	36	36			11.0		1			1	1		S	Telespar	Remove and Reset Existing Sign on New Post											
562+71	Lt.	Mile Marker 128.23 (Two Signs)	D10-6	4.5	21	1.3		5.0		1		1				E/W	U Channel	Replace Existing Sign with New Sign on New Post at Existing MRM Location											
562+74	Lt.	SD Hwy 28 (Two Signs)	D3-1	42	12	7.0			13.0		1	1				N/S	Telespar	Replace Existing Signs with New Signs on New Post											
		<- SD Hwy 15 (Two Signs)	D3-1	48	12	4.0													W										
		SD Hwy 15 -> (Two Signs)	D3-1	48	12	4.0													E										
		476 Ave ^ (Two Signs)	D3-1	48	12	4.0													N										
		SD Hwy 15 ^ (Two Signs)	D3-1	48	12	4.0													S										
		476 Ave -> (Two Signs)	D3-1	48	12	4.0													W										
476 Ave <- (Two Signs)	D3-1	48	12	4.0		E																							
564+02	Rt.	EAST	M3-2	24	12			11.5		1			1	1		W	Telespar	Remove and Reset Existing Sign on New Post											
		SD 28	M1-5	24	24																								
565+30	Lt.	WEST	M3-4	24	12	2.0		24.0		2						E	Telespar	Place New Sign											
		SD 28	M1-5	24	24																						Remove and Reset Existing Sign on New Post		
		Vertical Single Arrow	M6-3	21	15																							Place New Sign	
		North	M3-1	24	12	2.0																							Remove and Reset Existing Sign
		SD 15	M1-5	24	24																								
Horizontal Arrow	W1-7	21	15																										
566+09	Rt.	Adopt A Highway	ADO-5	36	36																								
		Courtesy of	ADO-1	36	18							1					W	Telespar	Remove Existing Signs										
		Litter Crew Ahead	ADO-6	30	30																								
TOTAL						582.3	104.4	706.5	115.0	70.0	9.0	91	30	29	28														

PLOT SCALE - 1:227.601

PLOTTED FROM - TRAB10100

Sign Summary SD 28

STATE OF SOUTH DAKOTA	PROJECT	SHEET NO.	TOTAL SHEETS
	P-PH 0028(36)355	S12	S22

Plotting Date: 01/26/2024

Revised 8/12/2024 AT

Sign Code	Description	Width (Inches)	Height (Inches)	Sq. Ft.	No.	Flat Aluminum Sign, Nonremovable Copy High Intensity (SQFT)	Flat Aluminum Sign, Nonremovable Copy Super or Very High Intensity (SQFT)	Text / Background
	UNMUFFLED DYNAMIC ENGINE BRAKING PROHIBITED By City Ordinance	30	36	7.5	1	7.5		Black on White/Black Border
D1-1	Estelline POP 749	60	18	7.5	1	7.5		White on Green
D1-2	Estelline 7 Hwy 81 20	60	36	15.0	1	15.0		White on Green
D1-2	^ Toronto ^ Watertown Brookings -->	108	60	45.0	1	45.0		White on Green
D1-2	^ Estelline <-- Brookings	66	30	13.8	1	13.8		White on Green
D1-2	^ Toronto <-- Watertown	96	48	32.0	1	32.0		White on Green
D1-2	^ Estelline <-- Brookings Watertown -->	108	60	45.0	1	45.0		White on Green
D1-2	Toronto 6 Clear Lake 15	96	36	24.0	1	24.0		White on Green
D3-1	Street Signs SD Hwy 28 (Two Signs for Each)	42	12	3.5	20	70.0		White on Green
D3-1	Street Signs 466 Ave - 468 Ave, 470 Ave - 475 Ave (Two Signs for Each)	36	12	3.0	18	54.0		White on Green
D3-1	Street Sign ^ SD Hwy 15	48	12	4.0	1	4.0		White on Green
D3-1	Street Sign SD Hwy 15 ->	48	12	4.0	1	4.0		White on Green
D3-1	Street Sign <- SD Hwy 15	48	12	4.0	1	4.0		White on Green
D3-1	Street Sign 476 Ave ^	48	12	4.0	1	4.0		White on Green
D3-1	Street Sign 476 Ave ->	48	12	4.0	1	4.0		White on Green
D3-1	Street Sign <- 476 Ave	48	12	4.0	1	4.0		White on Green
D9-9	LODGING (SYM)	24	24	4.0	2	8.0		White on Blue/White Border
D9-7	GAS (SYM)	24	24	4.0	2	8.0		White on Blue/White Border
D10-6	Mile Markers 356-365 (Two Signs for Each)	4.5	18	0.6	20	11.3		White on Green
D10-6	Mile Markers 357.02, 361.61, 364.22, 365.16, 128.23 (Two Signs for Each)	4.5	21	0.7	10	6.6		White on Green
R3-9dP	End Marker	18	12	1.5	1	1.5		Black on White/Black Border
M1-1	I 29	24	24	4.0	7	28.0		
M1-5	SD 15	24	24	4.0	2	8.0		See Standard Plate 632.20
M1-5	SD 28	24	24	4.0	9	36.0		See Standard Plate 632.20
M2-1	Junction Marker	21	15	2.2	2	4.4		White on Blue/White Border
M2-1	Junction Marker	21	15	2.2	1	2.2		Black on White/Black Border
M3-1	North	24	12	2.0	2	4.0		White on Blue/White Border
M3-1	North	24	12	2.0	2	4.0		Black on White/Black Border
M3-2	East	24	12	2.0	4	8.0		Black on White/Black Border
M3-3	South	24	12	2.0	3	6.0		White on Blue/White Border
M3-4	West	24	12	2.0	5	10.0		Black on White/Black Border
M6-1	Horizontal Arrow	21	15	2.2	6	13.1		White on Blue/White Border
M6-1	Horizontal Arrow	21	15	2.2	0	0.0		Black on White/Black Border
M6-3	Vertical Single Arrow	21	15	2.2	1	2.2		White on Blue/White Border
M6-3	Vertical Single Arrow	21	15	2.2	4	8.8		Black on White/Black Border
M6-4	Horizontal Double Head Arrow	21	15	2.2	2	4.4		Black on White/Black Border
R1-1	Stop	30	30	5.2	4		20.8	White on Red
R1-1	Stop	36	36	7.7	4		30.8	White on Red
R1-2	Yield	36X36X36		7.8	1		7.8	White on Red
R2-1	Speed Limit 65	24	30	5.0	2	10.0		Black on White
R5-1	DO NOT ENTER	36	36	9.0	5		45.0	Red on White
R6-1L	ONE WAY ON LEFT ARROW	54	18	6.8	4	27.0		Black on White
R6-1R	ONE WAY ON RIGHT ARROW	54	18	6.8	4	27.0		Black on White
SW3-1	7 MILES	36	12	3.0	2	6.0		White on Blue/White Border
					Totals	582.3	104.4	

PLOT NAME - 1

FILE - ... \BROK05EX\SECTION SAT.TITLES.DGN

STATE OF SOUTH DAKOTA	PROJECT	SHEET NO.	TOTAL SHEETS
	P-PH 0028(36)355	S13	S22

Plotting Date: 01/26/2024

Revised 8/07/2024 AT

SPECIAL SIGN LAYOUT

PLOT SCALE - 1:227.601

PLOT NAME - 1

FILE - ... \BROK05EX\SECTION S\TTILES.DGN

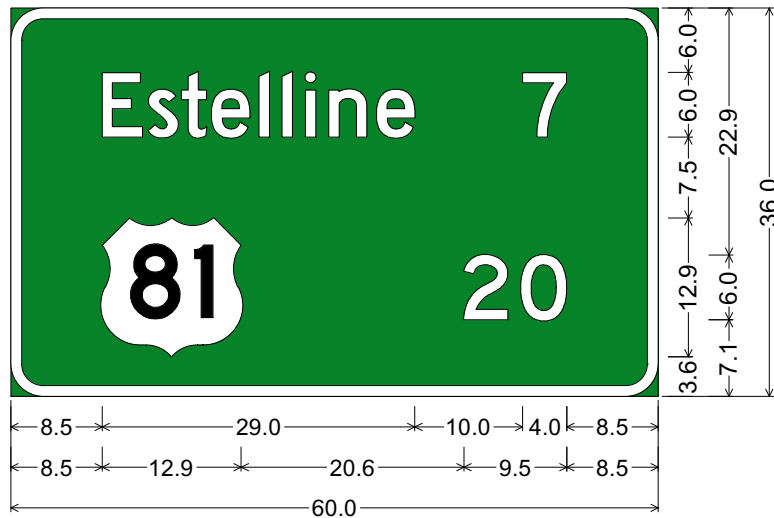

3.0" Radius, 1.0" Border, White on Green;
"Estelline", D 2K; "7", D 2K; "20", D 2K;

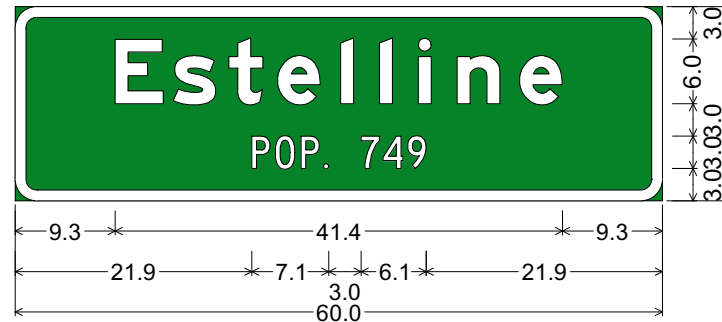

2.0" Radius, 1.0" Border, White on Green;
"Estelline", E Mod 2K; "POP. 749", C 2K;

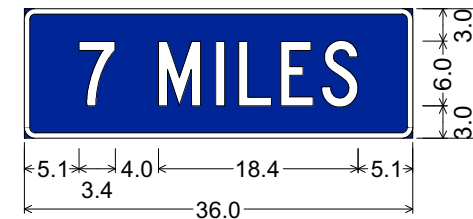

1.0" Radius, 0.5" Border, White on Blue;
"7", C 2K; "MILES", C 2K;

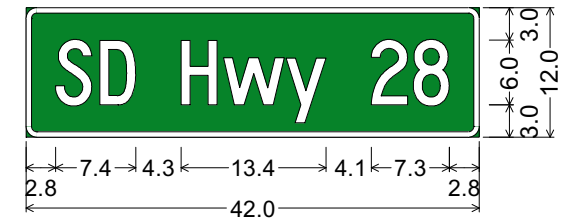

1.0" Radius, 0.5" Border, White on Green;
"SD Hwy 28", C 2K 70% spacing;

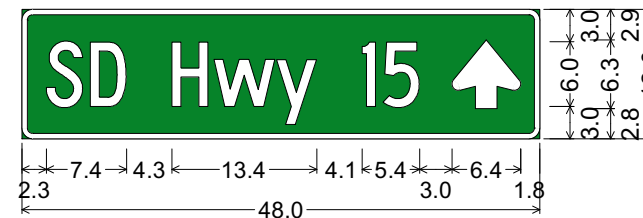

1.0" Radius, 0.5" Border, White on Green;
"SD Hwy 15", C 2K 70% spacing;
Standard Arrow Custom 6.4" X 6.4" 90°;

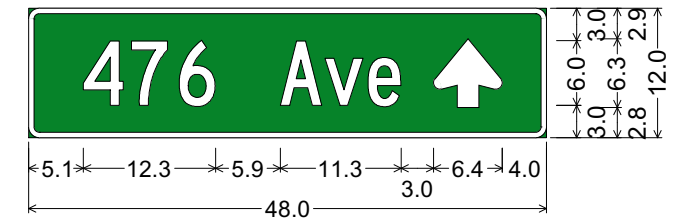

1.0" Radius, 0.5" Border, White on Green;
"476 Ave", C 2K;
Standard Arrow Custom 6.4" X 6.4" 90°;

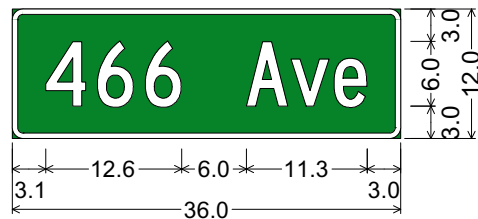

1.0" Radius, 0.5" Border, White on Green;
"466 Ave", C 2K;

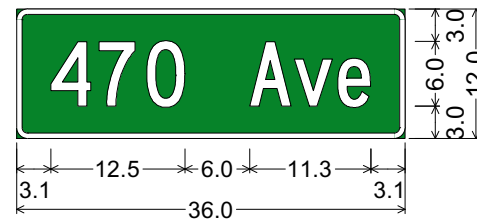

1.0" Radius, 0.5" Border, White on Green;
"470 Ave", C 2K;

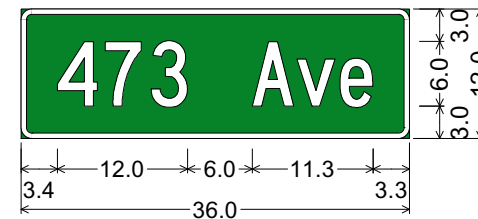

1.0" Radius, 0.5" Border, White on Green;
"473 Ave", C 2K;

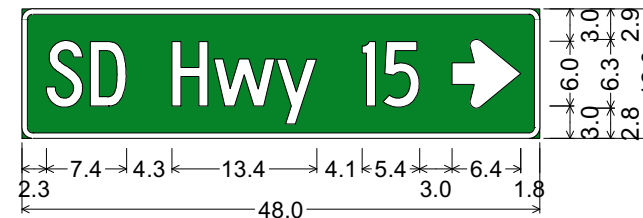

1.0" Radius, 0.5" Border, White on Green;
"SD Hwy 15", C 2K 70% spacing;
Standard Arrow Custom 6.4" X 6.4" 0°;

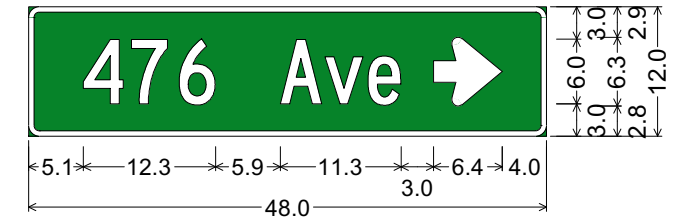

1.0" Radius, 0.5" Border, White on Green;
"476 Ave", C 2K;
Standard Arrow Custom 6.4" X 6.4" 0°;

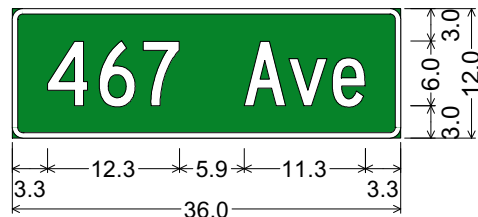

1.0" Radius, 0.5" Border, White on Green;
"467 Ave", C 2K;

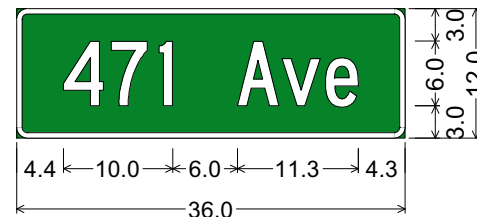

1.0" Radius, 0.5" Border, White on Green;
"471 Ave", C 2K;

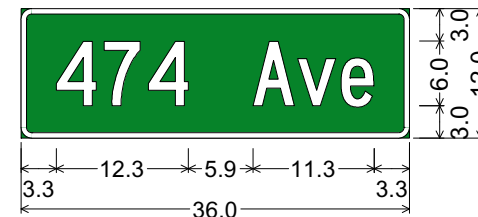

1.0" Radius, 0.5" Border, White on Green;
"474 Ave", C 2K;

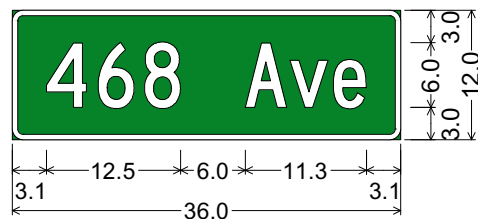

1.0" Radius, 0.5" Border, White on Green;
"468 Ave", C 2K;

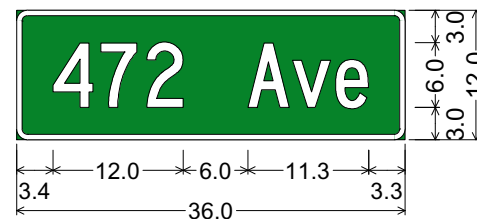

1.0" Radius, 0.5" Border, White on Green;
"472 Ave", C 2K;

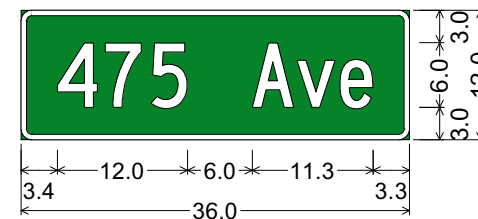

1.0" Radius, 0.5" Border, White on Green;
"475 Ave", C 2K;

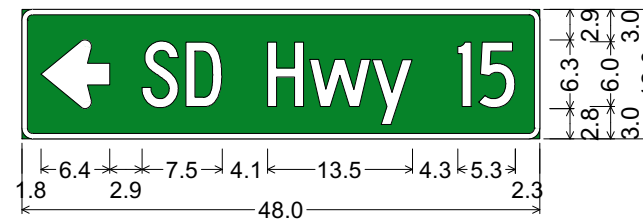

1.0" Radius, 0.5" Border, White on Green;
Standard Arrow Custom 6.4" X 6.4" 180°;
"SD Hwy 15", C 2K 70% spacing;

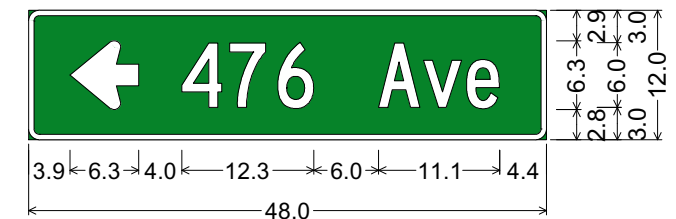

1.0" Radius, 0.5" Border, White on Green;
Standard Arrow Custom 6.4" X 6.4" 180°;
"476 Ave", C 2K;

PLOTTED FROM - TRAB10100

STATE OF SOUTH DAKOTA	PROJECT	SHEET NO.	TOTAL SHEETS
	P-PH 0028(36)355	S14	S22
Plotting Date: 01/26/2024			

SPECIAL SIGN LAYOUT

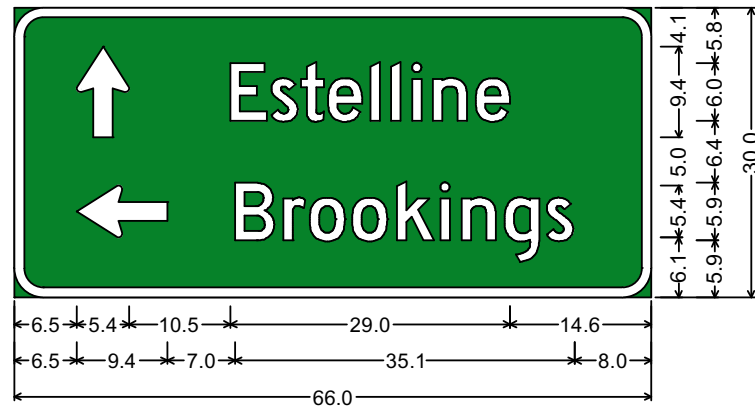

3.0" Radius, 1.0" Border, White on Green;
Standard Arrow 2 9.4" X 5.4" 90°; "Estelline", D 2K;
Standard Arrow 2 9.4" X 5.4" 180°; "Brookings", D 2K;



6.0" Radius, 1.3" Border, White on Green;
Standard Arrow 2.25 9.9" X 6.1" 90°; "Toronto", D 2K;
Standard Arrow 2.25 9.9" X 6.1" 180°; "Watertown", D 2K;

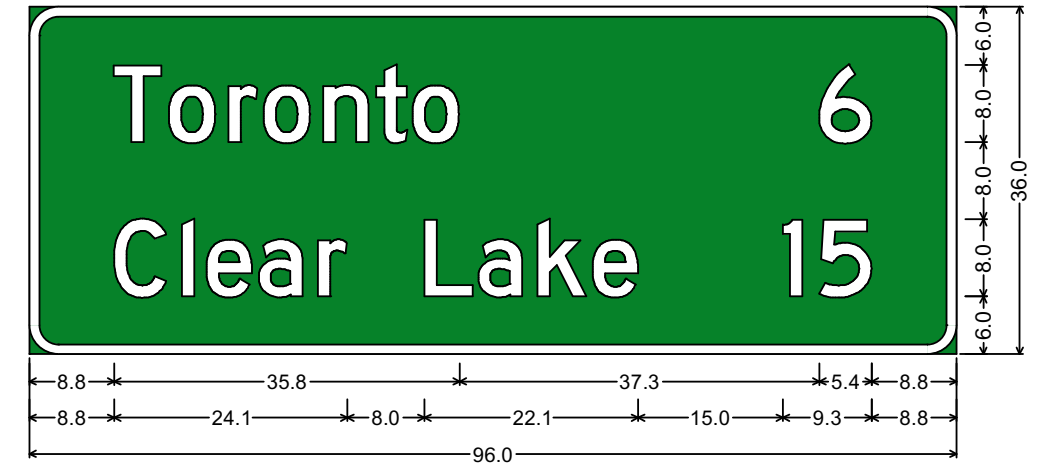

3.0" Radius, 1.0" Border, White on Green;
"Toronto", D 2K; "6", D 2K; "Clear Lake", D 2K; "15", D 2K;

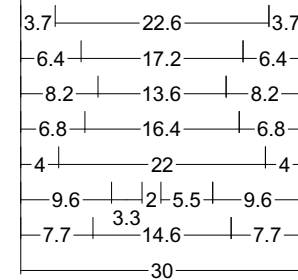
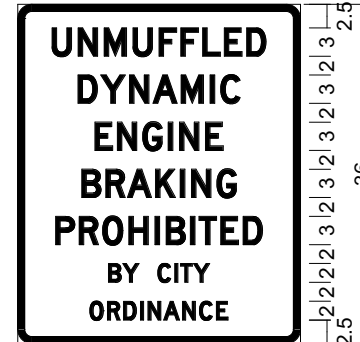

1.5" Radius, 0.8" Border, Black on, White;
"UNMUFFLED", D 2K;
"DYNAMIC", D 2K;
"ENGINE", D 2K;
"BRAKING", D 2K;
"PROHIBITED", D 2K;
"BY CITY", D 2K;
"ORDINANCE", D 2K;



6.0" Radius, 1.3" Border, White on Green;
Standard Arrow 2.25 9.9" X 6.1" 90°; "Estelline", D 2K; Standard Arrow 2.25 9.9" X 6.1" 90°;
"Brookings", D 2K; "Watertown", D 2K; Standard Arrow 2.25 9.9" X 6.1" 0°;



6.0" Radius, 1.3" Border, White on Green;
Standard Arrow 2.25 9.9" X 6.1" 90°; "Toronto", D 2K; Standard Arrow 2.25 9.9" X 6.1" 90°;
"Watertown", D 2K; "Brookings", D 2K; Standard Arrow 2.25 9.9" X 6.1" 0°;

BREAKAWAY SIGN SUPPORTS

SIGN BASE DETAILS FOR A 2" SIGN POST

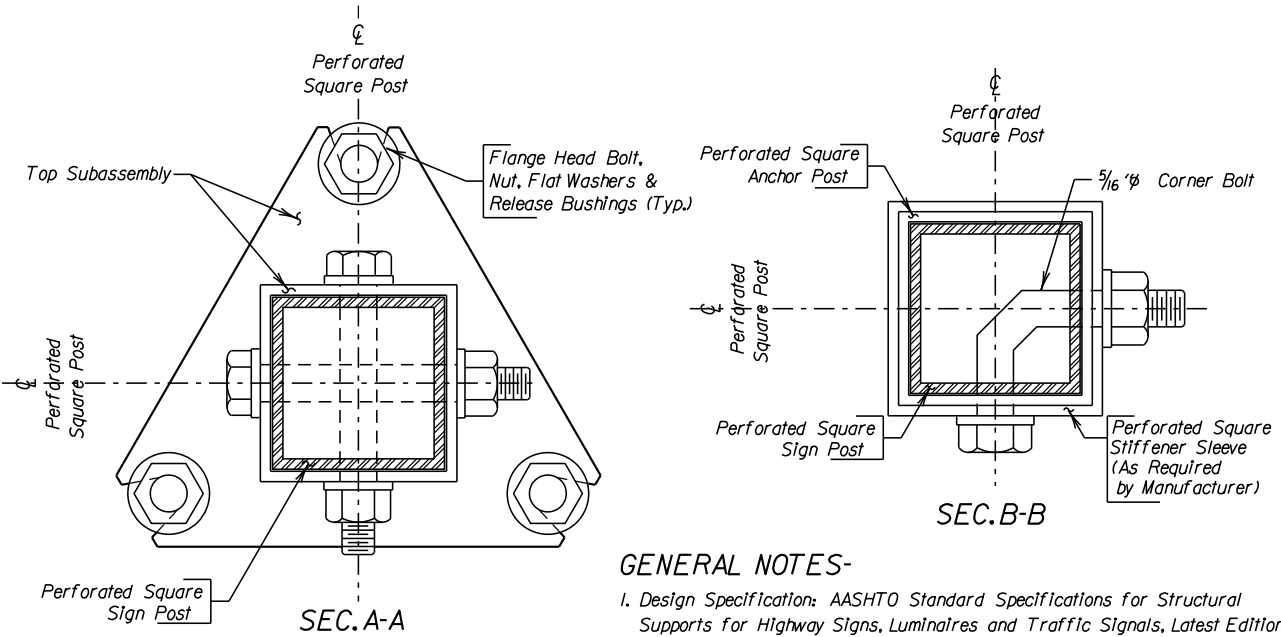

GENERAL NOTES-

1. Design Specification: AASHTO Standard Specifications for Structural Supports for Highway Signs, Luminaires and Traffic Signals, Latest Edition.
2. The manufacturer will provide certification that the posts and hardware furnished have essentially the same chemistry, mechanical properties and geometry as that used in the FHWA tests, and that it will meet the FHWA change in velocity requirements.
3. The manufacturer will also provide certification that the breakaway system furnished will develop the full shear and bending yield strength of the sign post section being spliced.
4. All posts will be galvanized in accordance with ASTM A653, Des. G-90.
5. All hardware will be galvanized in accordance with ASTM A153.

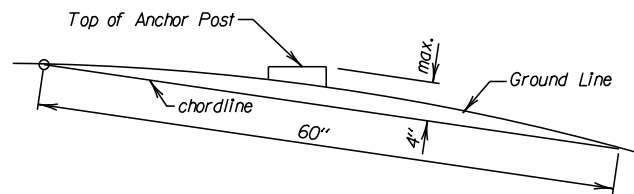

BREAKAWAY SUPPORT STUB CLEARANCE DIAGRAM

NOTE: The top of anchor post will NOT extend more than 4" max. above the chordline within a 60" chord.

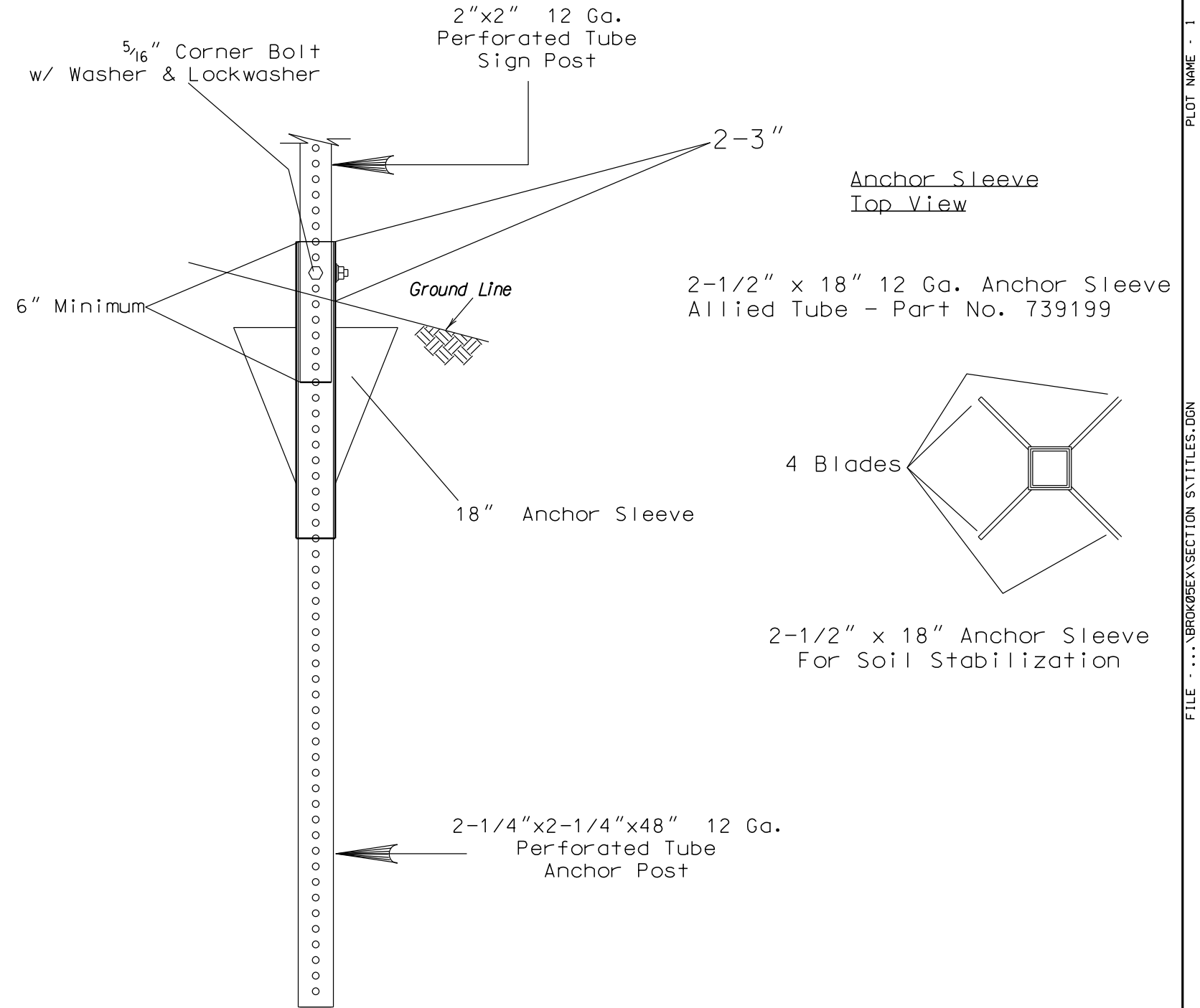

SIGN BASE DETAILS FOR A 2 1/2" SIGN POST

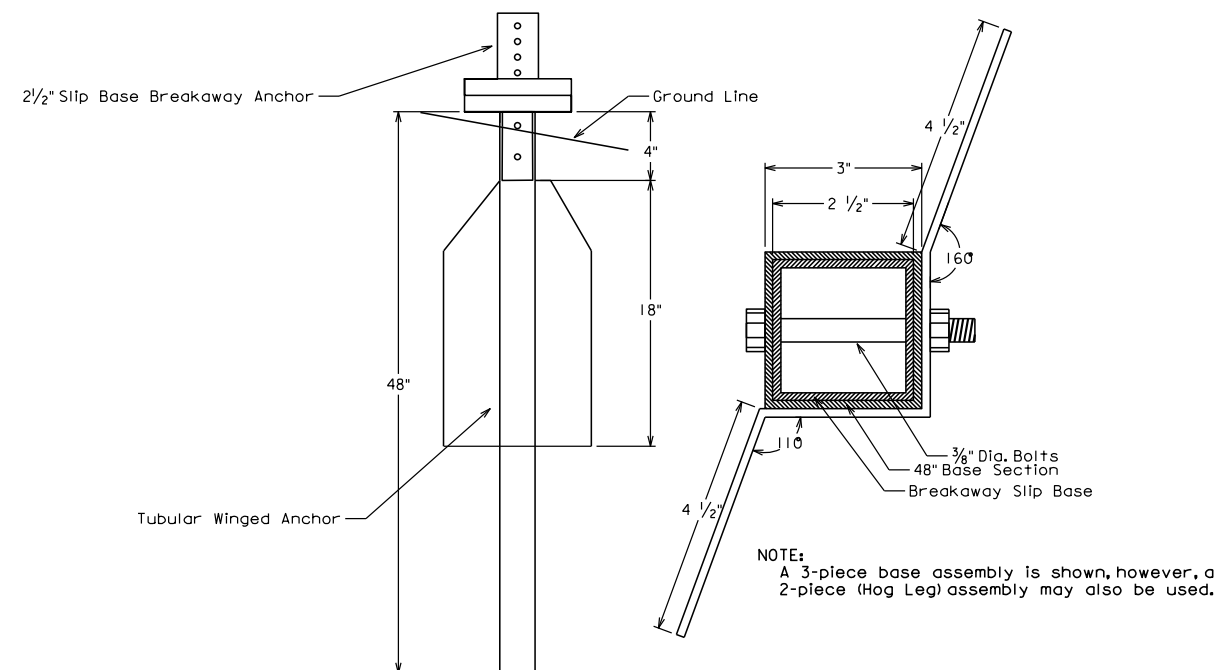

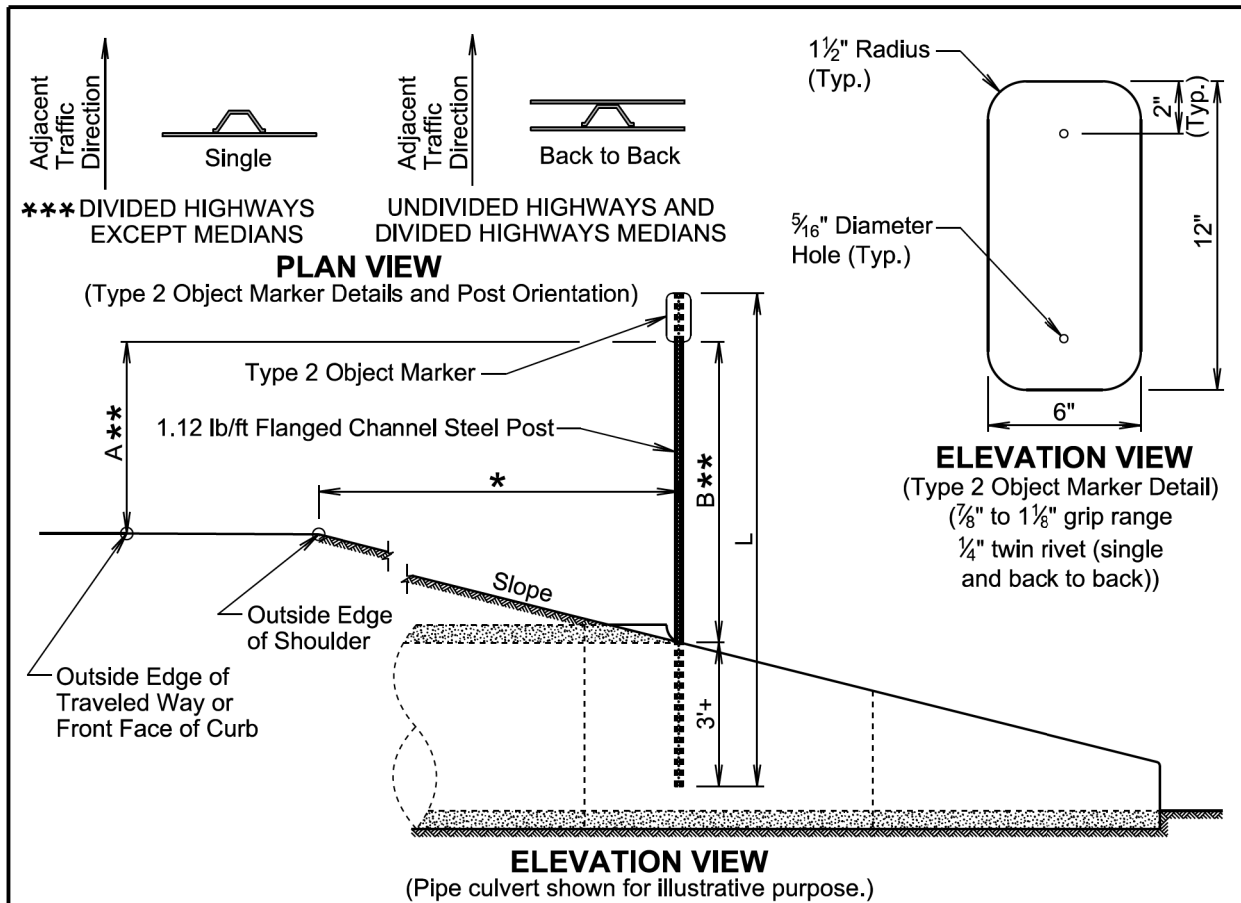

TYPE 2 OBJECT MARKER POST LENGTHS										
OFFSET (*)	1'	2'	3'	4'	5'	6'	7'	8'	Greater Than 8'	
POST LENGTH (L)										
SLOPE	3:1	8'-6"	8'-9"	9'-3"	9'-6"	9'-9"	10'-3"	10'-6"	10'-9"	8'-0"
	4:1	8'-6"	8'-9"	9'-0"	9'-3"	9'-9"	9'-9"	10'-0"	10'-3"	8'-0"
	5:1	8'-3"	8'-6"	8'-9"	9'-0"	9'-3"	9'-3"	9'-6"	9'-9"	8'-0"
	6:1	8'-3"	8'-6"	8'-9"	8'-9"	9'-0"	9'-3"	9'-3"	9'-6"	8'-0"

GENERAL NOTES:

- *** The type 2 object marker may be installed back to back when specified in the plans.
Post Length L was calculated based on a shoulder width of 6 feet at a crosslope of 4 percent and L was rounded up to the nearest 3 inches.
- ** Dimension A is 4 feet when the Offset * is 8 feet and less. Dimension B is 4 feet when Offset * is greater than 8 feet.
The type 2 object marker and the 1.12 lb/ft flanged channel steel post will be in conformance with Specifications Section 982.2 J.
Payment for the type 2 object marker will be in conformance with Specification Section 632.5 B.

December 23, 2019

SD DOT	TYPE 2 OBJECT MARKER (DIRECT DRIVE)	PLATE NUMBER 632.01
	Published Date: 2025	Sheet 1 of 1

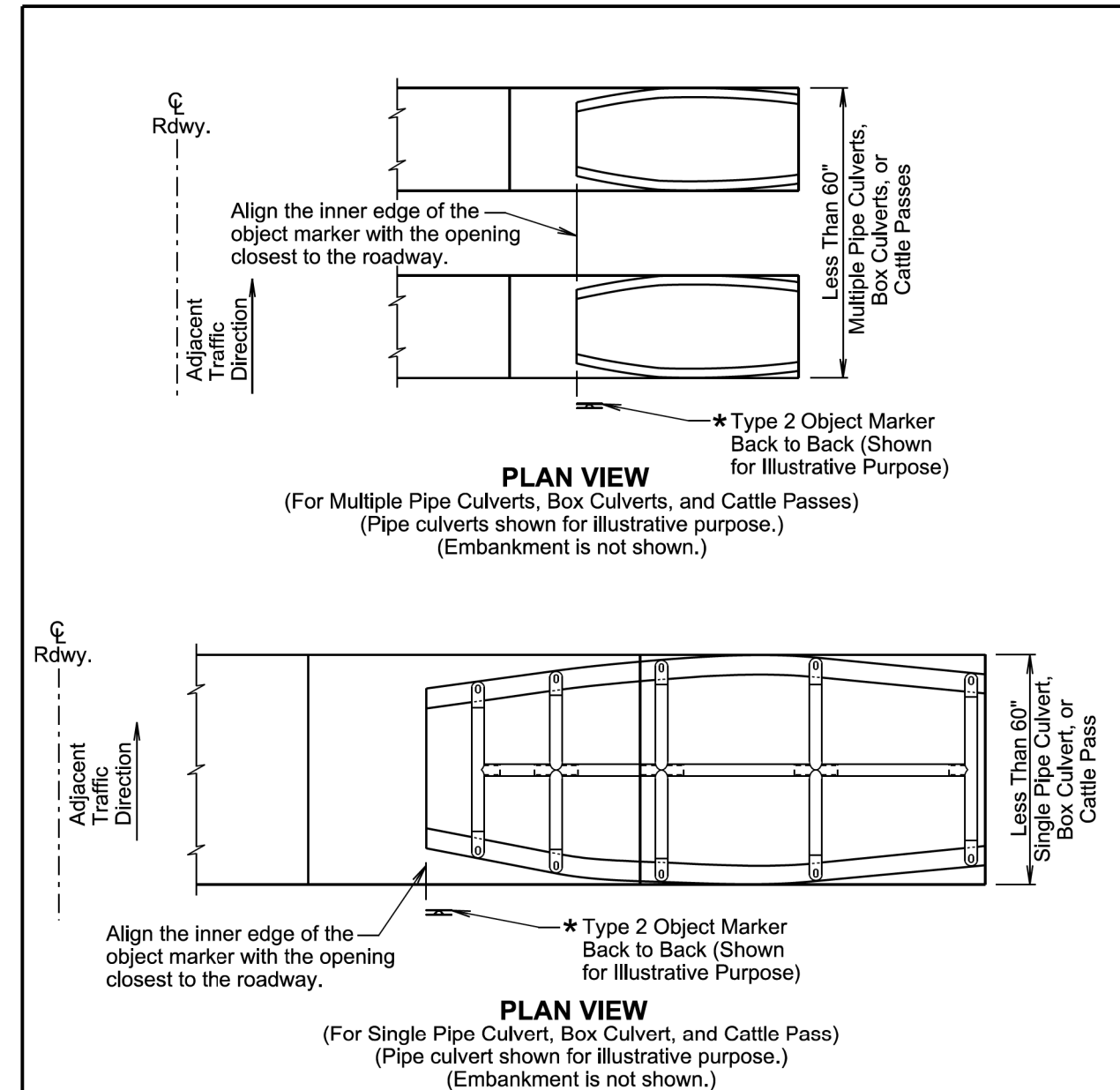

GENERAL NOTES:

- This standard plate will be used in conjunction with standard plate 632.01.
- * The type 2 object markers will be installed at the locations shown above. The type 2 object markers, single faced or back to back, will be as specified in the plans.

December 23, 2019

SD DOT	TYPE 2 OBJECT MARKER AT PIPE CULVERTS, BOX CULVERTS, AND CATTLE PASSES (Less than 60" Overall Width)	PLATE NUMBER 632.03
	Published Date: 2025	Sheet 1 of 1

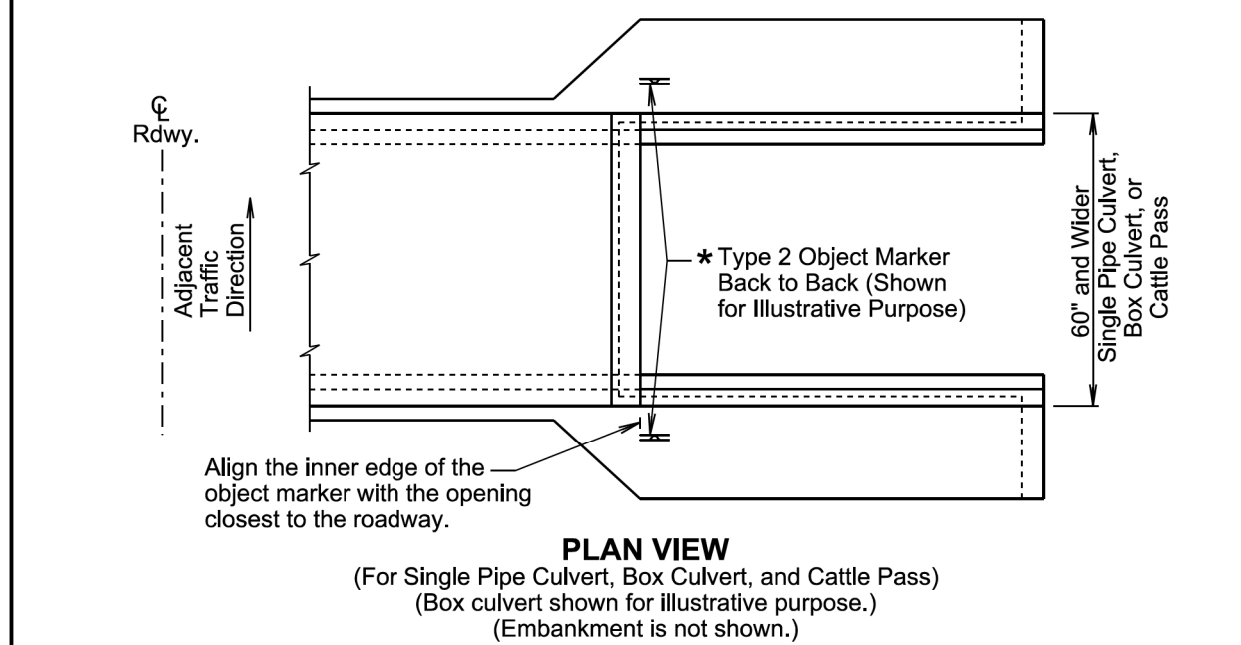
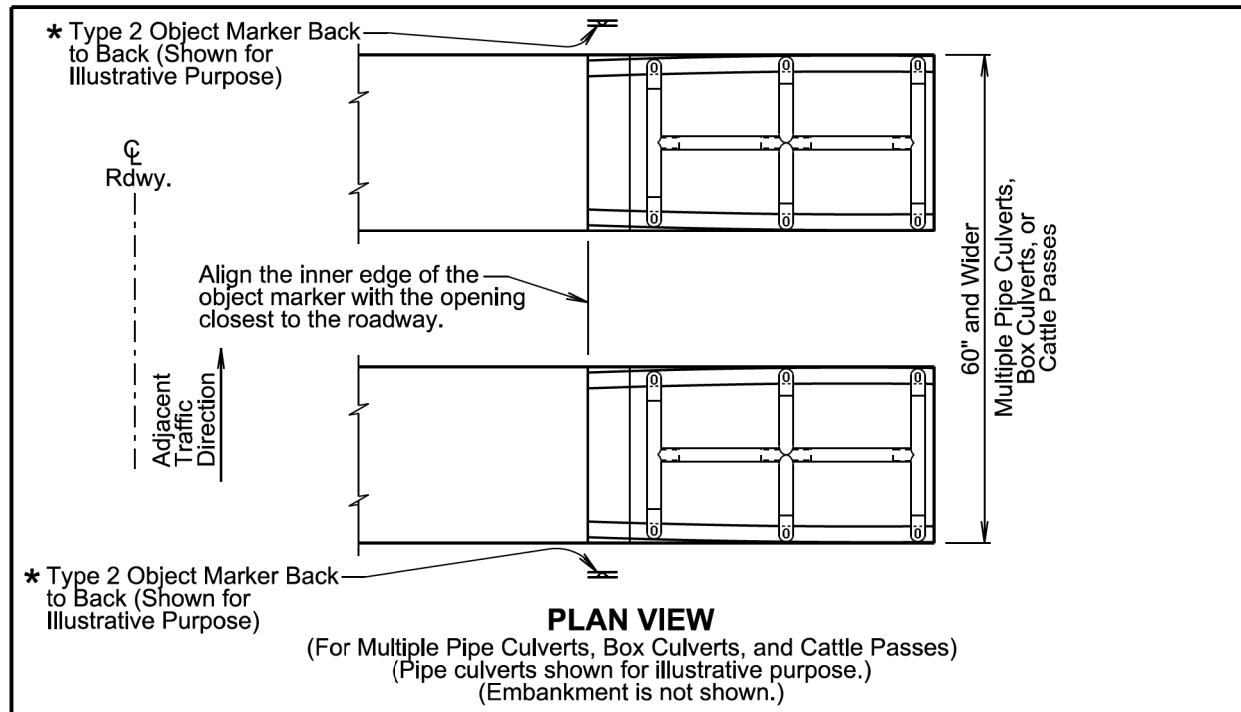

GENERAL NOTES:

This standard plate will be used in conjunction with standard plate 632.01.

* The type 2 object markers will be installed at the locations shown above. The type 2 object markers, single faced or back to back, will be as specified in the plans.

December 23, 2019

Published Date: 2025	S D D O T	TYPE 2 OBJECT MARKER AT PIPE CULVERTS, BOX CULVERTS, AND CATTLE PASSES (60" and Greater Overall Width)	PLATE NUMBER 632.04
			Sheet 1 of 1

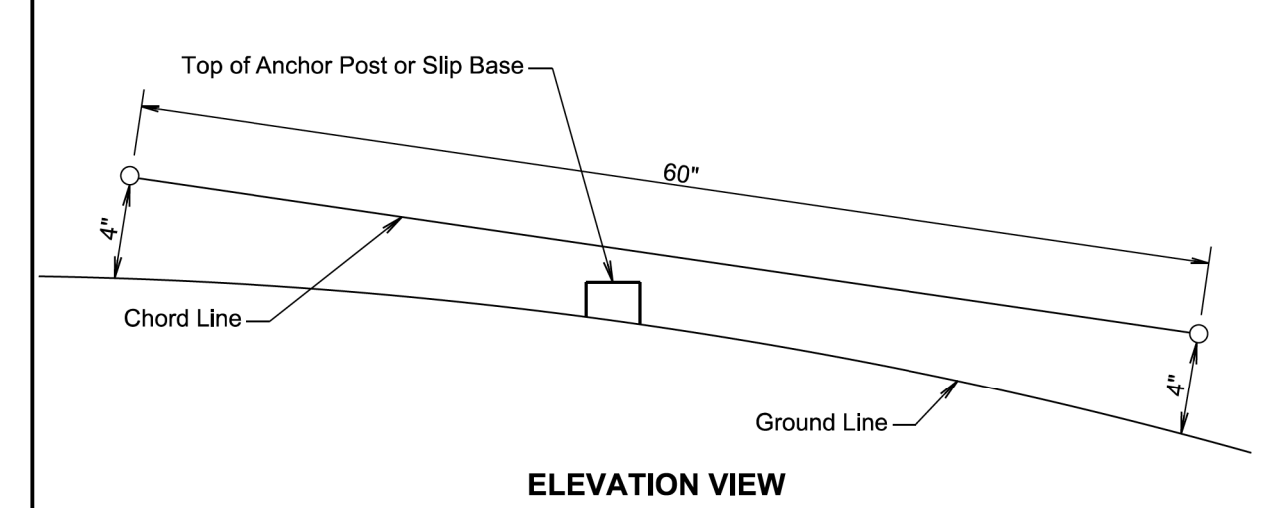
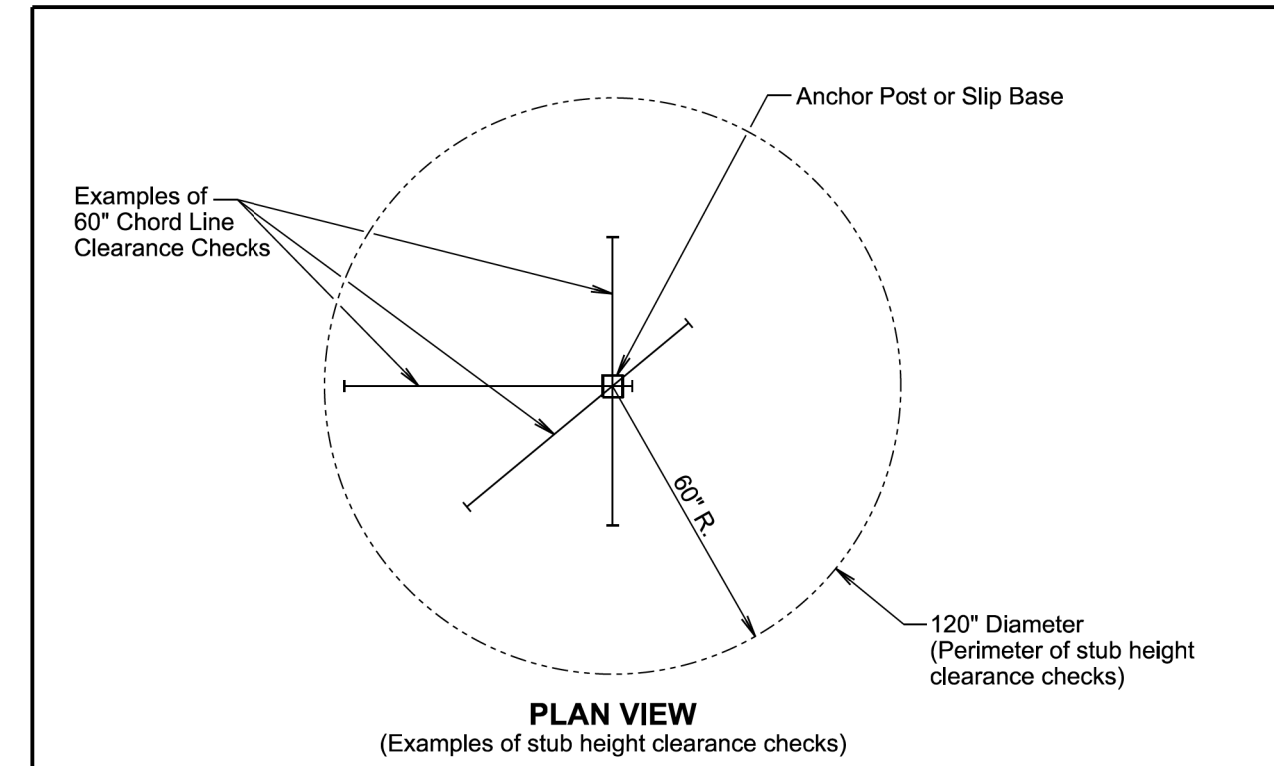

GENERAL NOTES:

The top of anchor posts and slip bases WILL NOT extend above a 60" chord line within a 120" diameter circle around the post with ends 4" above the ground.

At locations where there is curb and gutter adjacent to the breakaway sign support, the stub height will be a maximum of 4" above the ground line at the localized area adjacent to the breakaway support stub.

January 22, 2021

Published Date: 2025	S D D O T	BREAKAWAY SUPPORT STUB CLEARANCE	PLATE NUMBER 632.18
			Sheet 1 of 1

PLOT SCALE - 1:200

PLOTTED FROM - TRAB10100

PLOT NAME - 1

FILE - ... \04HM_STANDARD PLATES.DGN

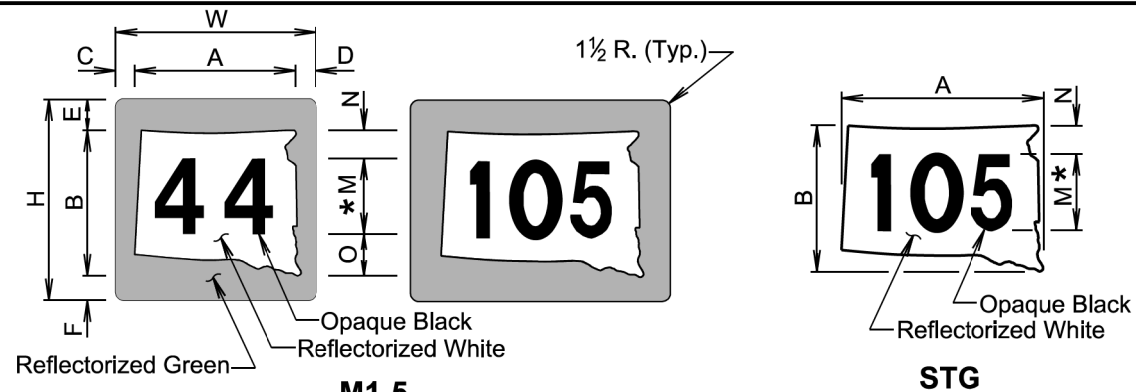

SIGN CODE	WxH	A	B	C	D	E	F	M*	N	O
M1-5	24x24	20½	18	2	1½	3½	2½	12D	2	4
M1-5 **	30x24	24	18	2¼	1¾	3½	2½	12D	2	4
M1-5	30x30	25⅞	22½	2½	1⅞	4⅜	3⅞	15D	2½	5
M1-5	36x36	30¾	27	3	2¼	5¼	3¾	18D	3	6

SIGN CODE	AxB	M*	N
STG-24	24x18	10D	4
STG-32	32x24	12D	4¾
STG-48	48x36	18D	7
STG-64	64x48	24D	9½

* In the few cases where there is not enough space for the numerals, the standard D series font may be replaced with C series font if approved by the Engineer.

** 3 Digits

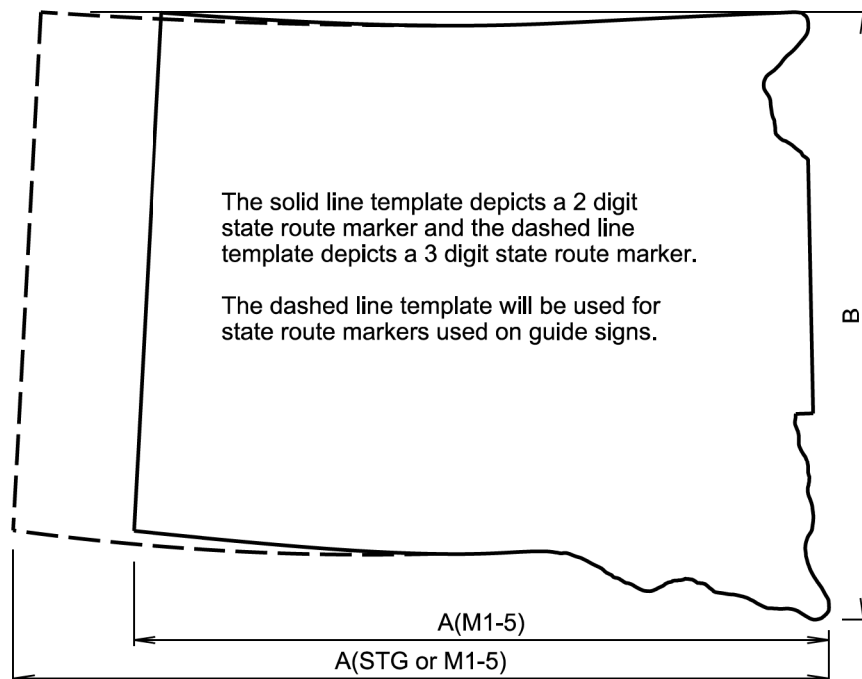

TEMPLATE FOR STATE ROUTE MARKER

GENERAL NOTES:

The unit for all dimensions shown is inches.

Numerals will be D series font for all state route markers except as noted above.

December 23, 2019

Published Date: 2025

S
D
D
O
T

STATE ROUTE MARKERS

PLATE NUMBER
632.20

Sheet 1 of 1

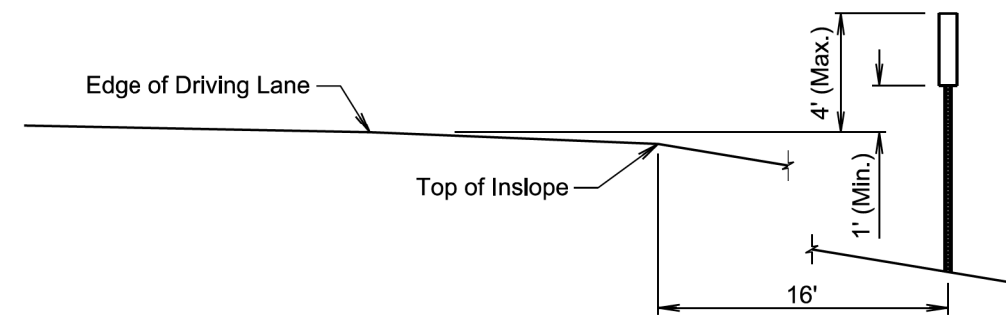
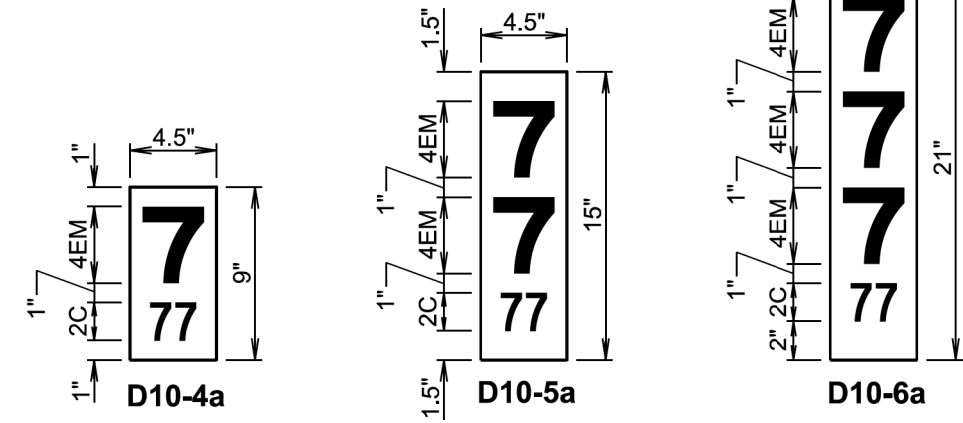
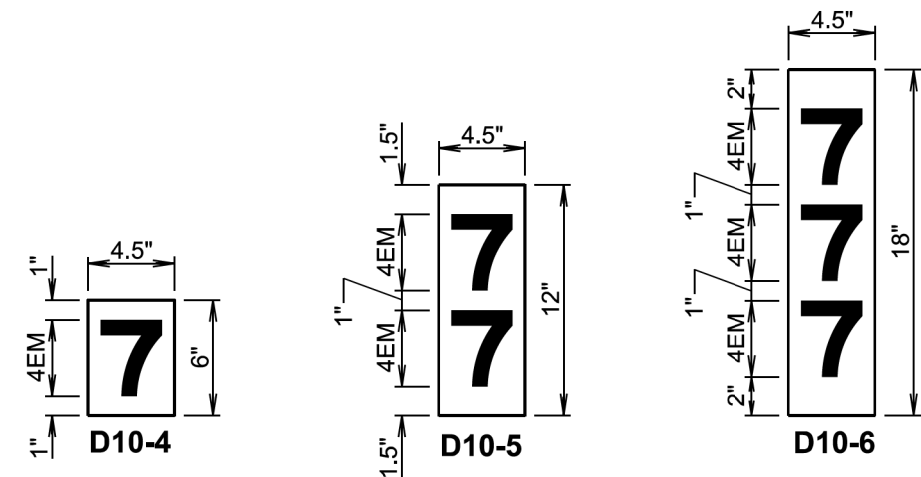

ELEVATION VIEW

GENERAL NOTES:

Background will be high intensity green.

Legend will be high intensity white.

Signs will have squared corners with no border.

Sign locations will be staked by the Engineer.

December 23, 2019

Published Date: 2025

S
D
D
O
T

NON-INTERSTATE
MILEAGE REFERENCE MARKERS

PLATE NUMBER
632.30

Sheet 1 of 1

STATE OF SOUTH DAKOTA	PROJECT	SHEET NO.	TOTAL SHEETS
	P-PH 0028(36)355	S19	S22
Plotting Date: 08/13/2024			

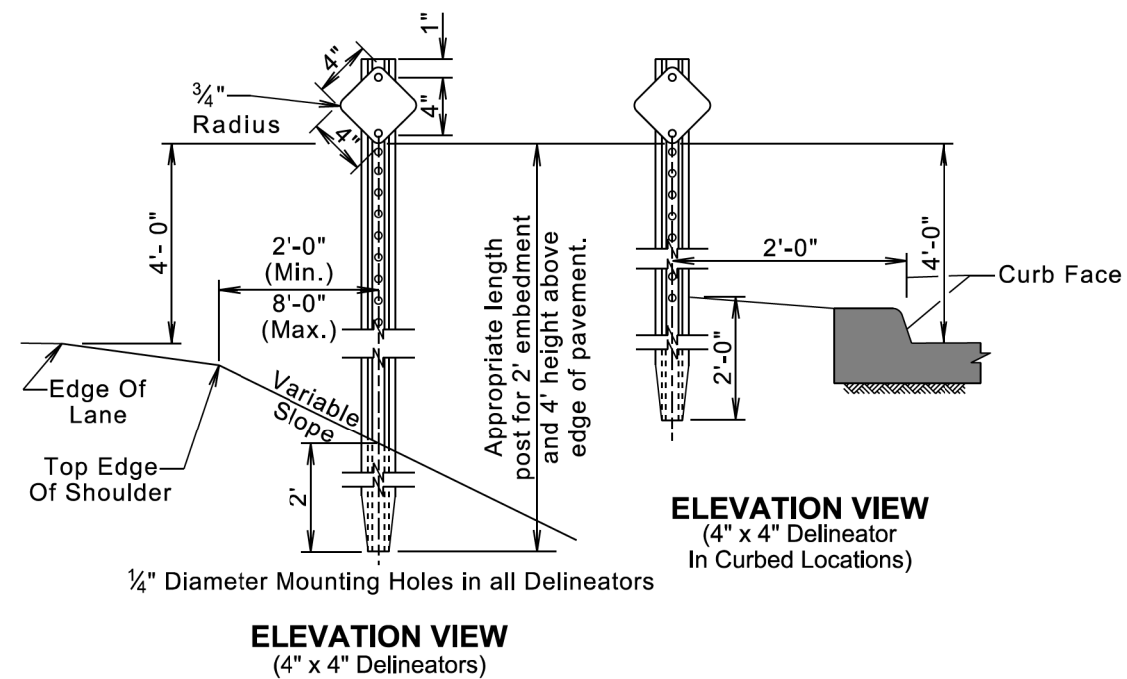
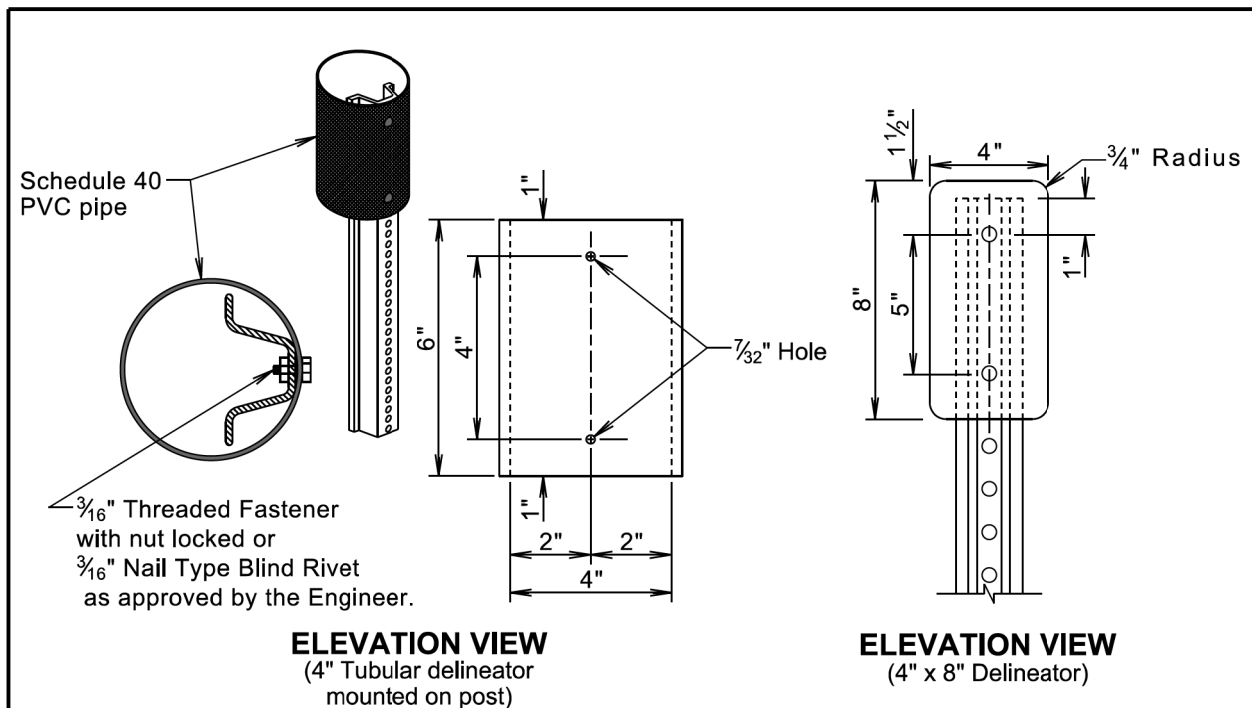

GENERAL NOTES:

Back-to-back delineation is required for two-way traffic, single-sided delineation for one-way traffic.

March 31, 2024

Published Date: 2025	S D D O T	DELINEATOR INSTALLATION DETAIL	PLATE NUMBER 632.42
			Sheet 1 of 1

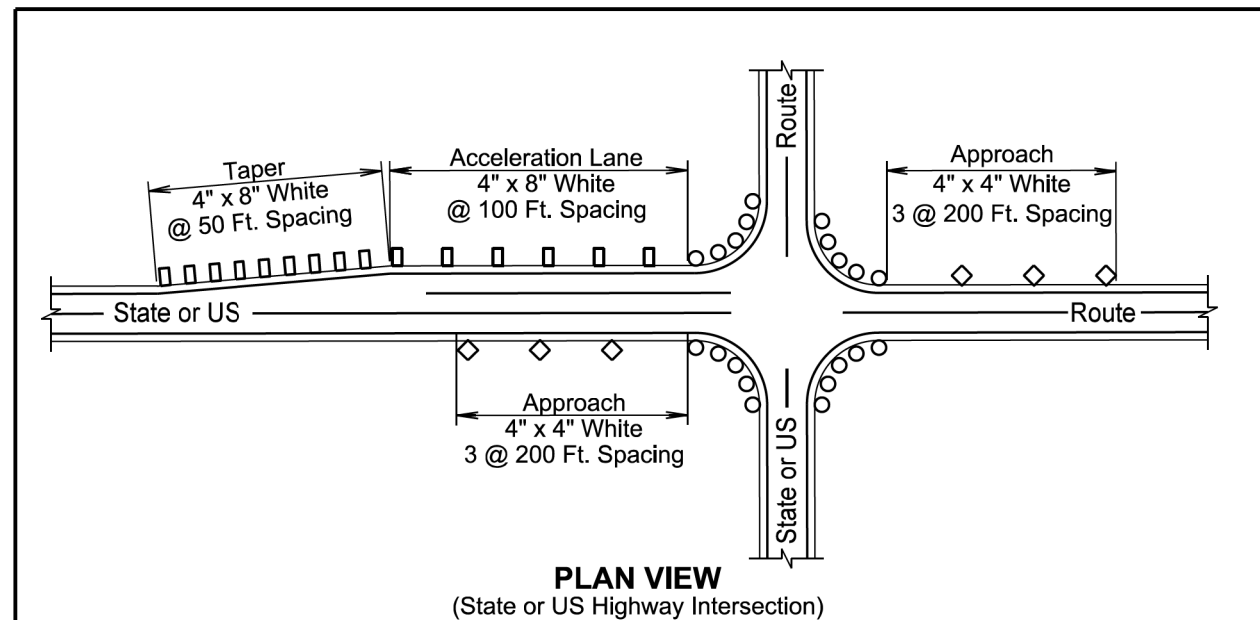

LEGEND	
◇	4" x 4" White Delineator
□	4" x 8" White Delineator
○	4" x 6" White Tubular Delineator

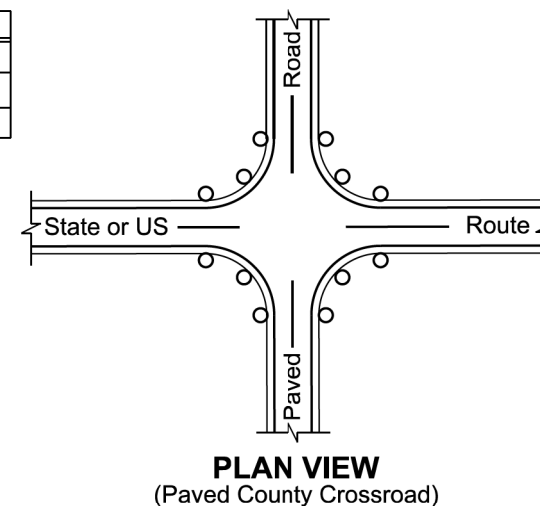

GENERAL NOTES:

At all intersections with State or US highways and paved county roads:

For radii greater than 100 feet, place 5 tubular white delineators on equally spaced posts around the turning radius.

For radii greater than 50 feet up to 100 feet, place 4 tubular white delineators on equally spaced posts around the turning radius.

For radii of 50 feet or less, place 3 tubular white delineators on equally spaced posts around the turning radius.

November 19, 2020

Published Date: 2025	S D D O T	DELINEATOR AT INTERSECTIONS	PLATE NUMBER 632.44
			Sheet 1 of 1

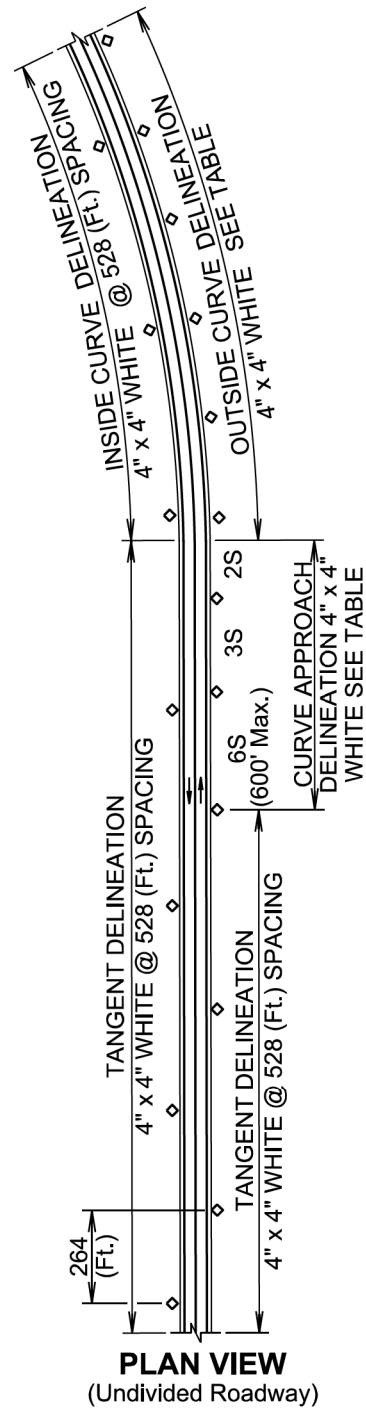
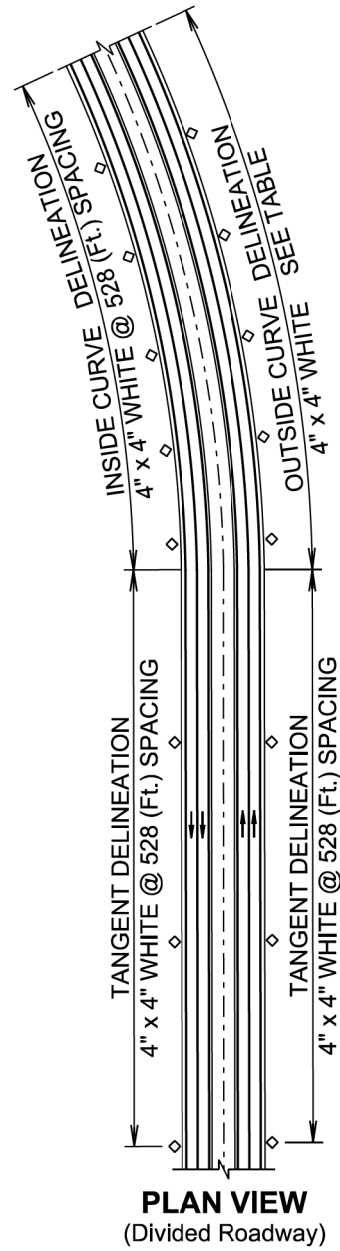

March 31, 2024

March 31, 2024

Published Date: 2025

**S
D
D
O
T**

DELINEATOR INSTALLATION SPACING

PLATE NUMBER
632.46

Sheet 1 of 2

GENERAL NOTES:

Delineators will be located from 2 to 8 feet outside of the outer edge of shoulder. When a roadside barrier or other obstruction intrudes into the space between the pavement edge and the extension of the line of delineators, the delineators should be in line with the barrier or in line with the innermost edge of the obstruction.

When normal spacing is interrupted by driveways, crossroads, or approaches, delineators falling within such areas may be moved in either direction a distance not exceeding one-quarter of the standard spacing. Delineators still falling within such areas should be eliminated.

The spacing for specific radii may be interpolated from the table. The minimum spacing should be 20 feet. The spacing on curves should not exceed 300 feet. In advance of or beyond a curve, and proceeding away from the end of the curve, the spacing of the first delineator is 2S, the second 3S, and the third 6S, but not to exceed 300 feet. S refers to the delineator spacing for specific radii computed from the formula $S = 3\sqrt{R - 50}$. The distances for S shown in the table were rounded to the nearest 5 feet.

Curve approach delineation is not required if curve delineation spacing exceeds 100 ft.

Back-to-back delineation is required for two-way traffic, single-sided delineation for one-way traffic.

DELINEATOR SPACING OUTSIDE CURVE				
Radius of Curve (Ft.)	Curve Delineator Spacing (Ft.)	Curve Approach Spacing (Ft.)		
		A	B	C
50	20	40	65	125
115	25	50	75	150
150	30	60	90	180
180	35	70	110	215
250	40	85	125	250
300	45	95	140	285
400	55	110	170	300
500	65	125	190	300
600	70	140	210	300
700	75	150	230	300
800	80	165	245	300
900	85	175	260	300
1000	90	185	275	300

Published Date: 2025

**S
D
D
O
T**

DELINEATOR INSTALLATION SPACING

PLATE NUMBER
632.46

Sheet 2 of 2

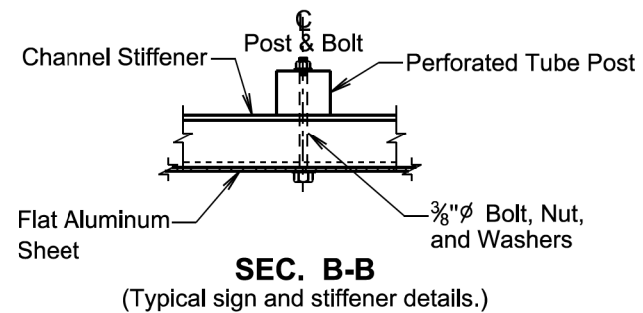
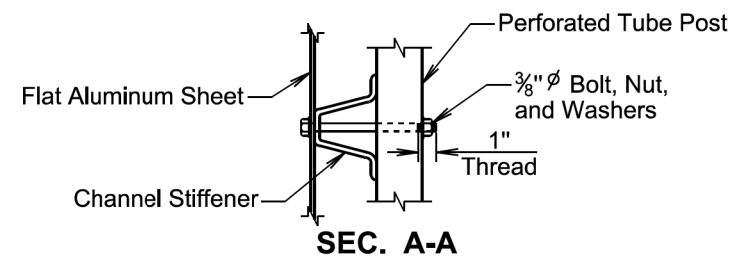
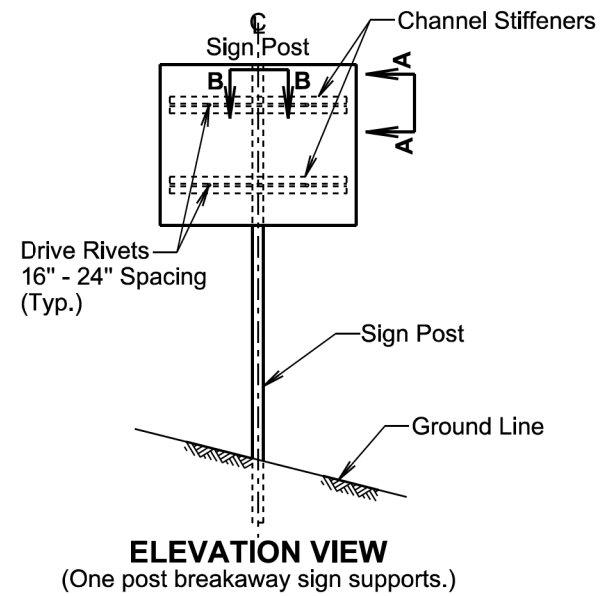

∅ A plastic washer, as recommended by the sheeting manufacturer, will be installed between the sign face and the metal washer shown.

November 19, 2020

Published Date: 2025

S
D
D
O
T

SIGN STIFFENER DETAILS

PLATE NUMBER
632.60

Sheet 1 of 2

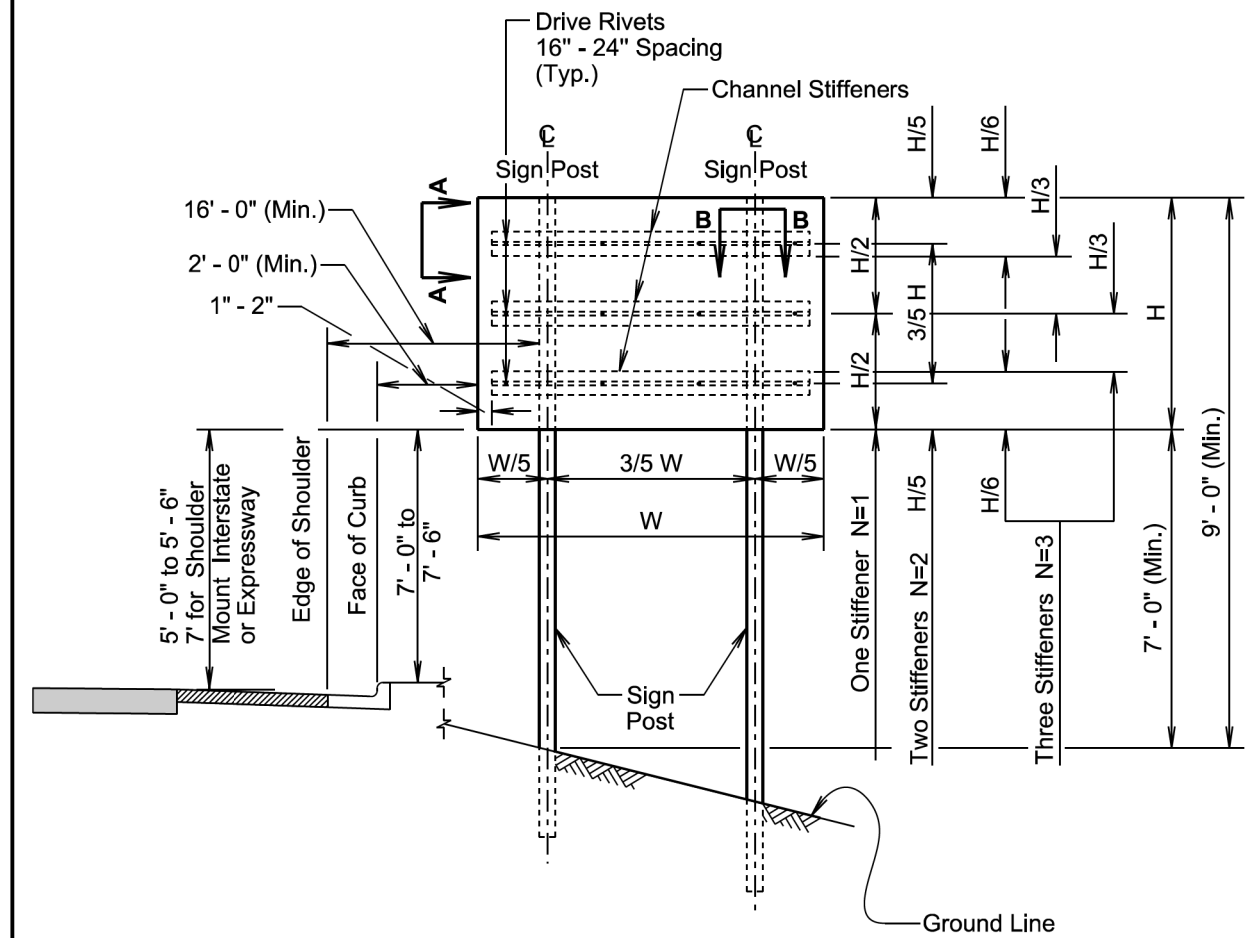

GENERAL NOTES:

The number of stiffeners used (N) will be as follows:
 If $H \leq 2' - 0''$ then $N = 1$
 if $2' - 0'' < H \leq 8' - 0''$ then $N = 2$
 if $8' - 0'' < H \leq 15' - 0''$ then $N = 3$
 where H is the vertical dimension of the sign.

A minimum of two bolts will be required to fasten the sign to each post.

November 19, 2020

Published Date: 2025

S
D
D
O
T

SIGN STIFFENER DETAILS

PLATE NUMBER
632.60

Sheet 2 of 2

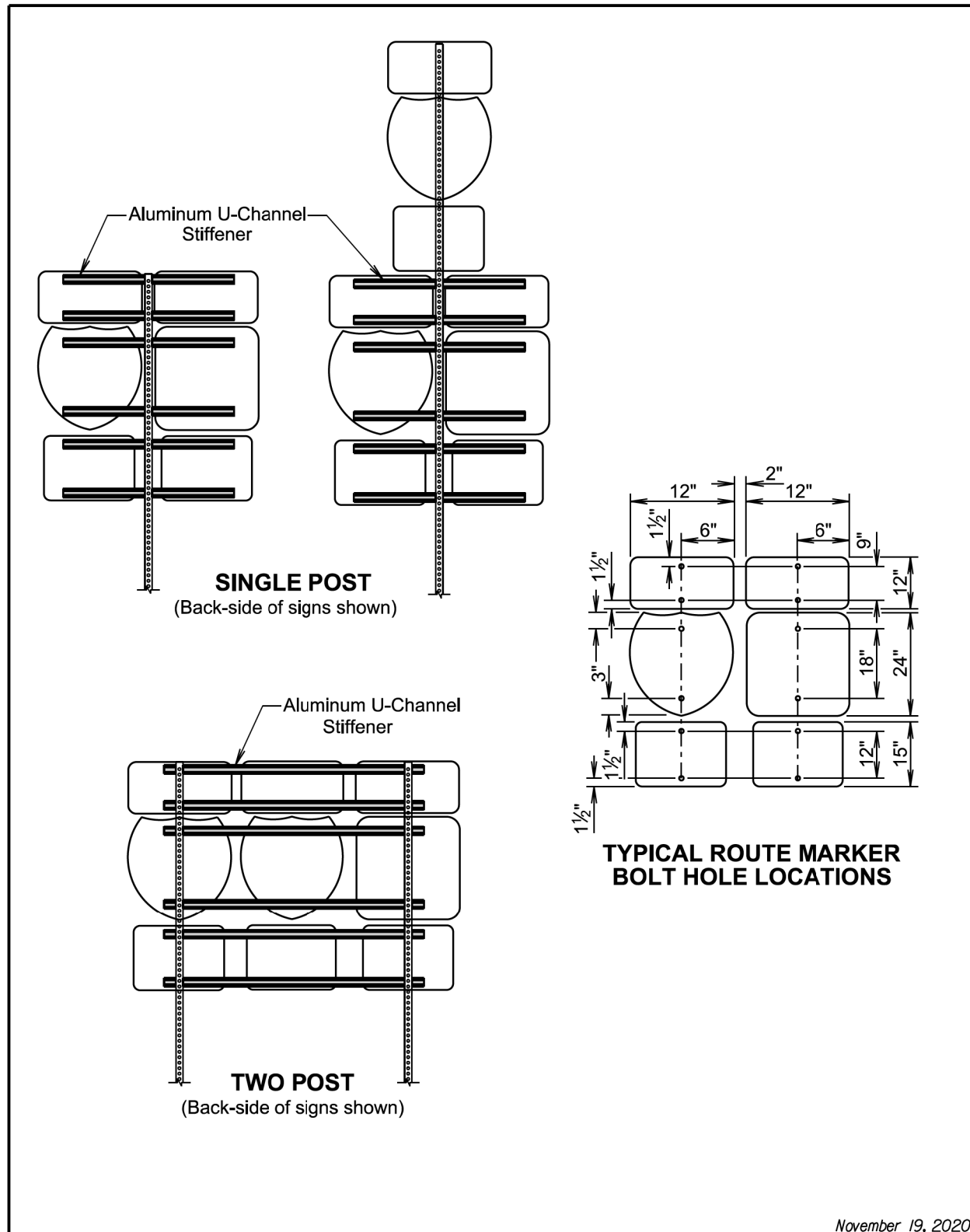

Published Date: 2025	S D D O T	MULTIPLE ROUTE MARKER SIGN STIFFENER INSTALLATION DETAILS	PLATE NUMBER 632.62
			Sheet 1 of 1

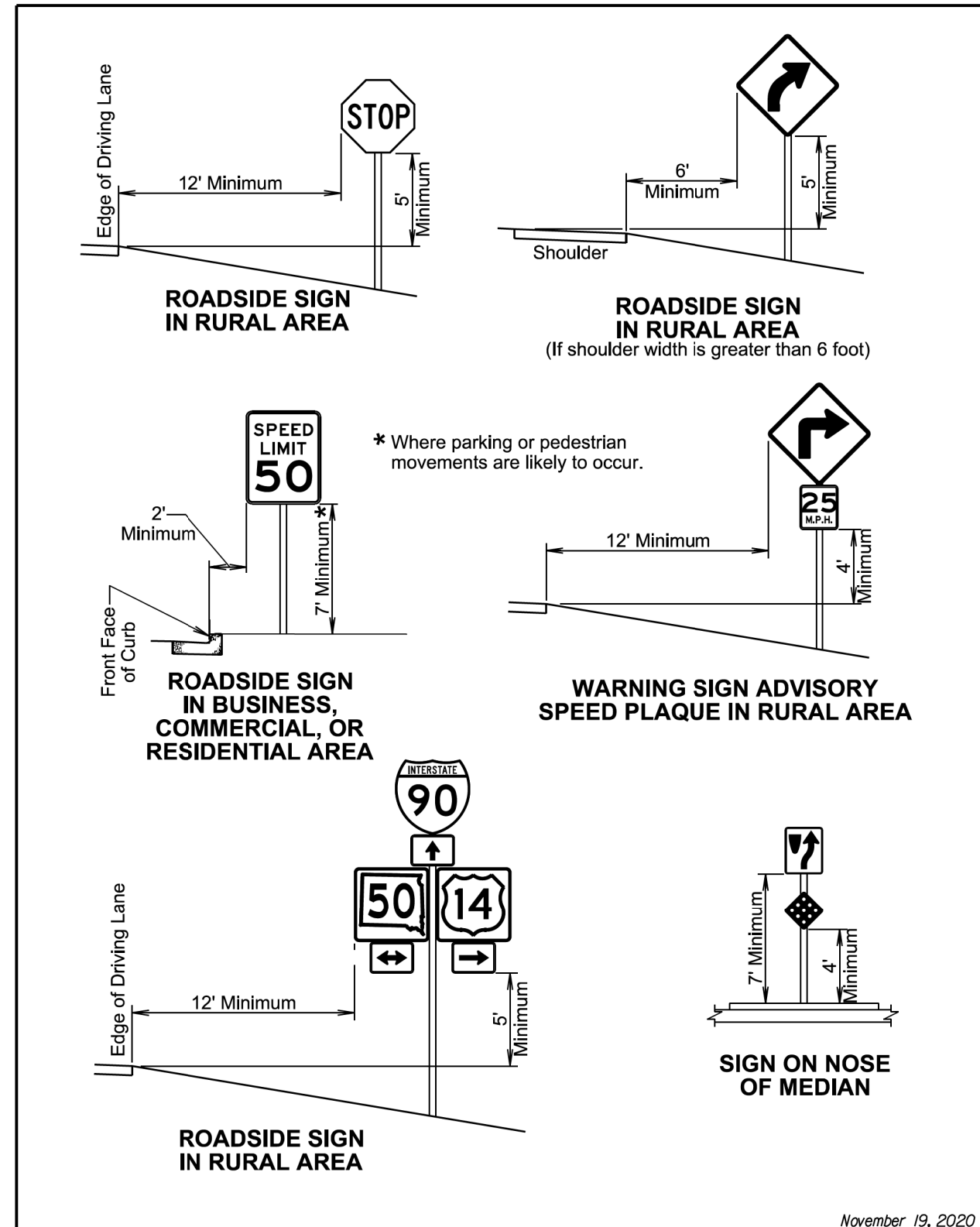

Published Date: 2025	S D D O T	OFFSETS FOR SIGN INSTALLATION	PLATE NUMBER 632.90
			Sheet 1 of 1