

SECTION F: SURFACING PLANS

FOR BIDDING PURPOSES ONLY

STATE OF SOUTH DAKOTA	PROJECT IM 2292(105)3	SHEET NO. F1	TOTAL SHEETS F20
-----------------------	--------------------------	-----------------	---------------------

Plotting Date: 03/01/2024

INDEX OF SHEETS

F1	General Layout with Index
F2-F3	Estimate with General Notes and Tables
F4-F8	In-Place Surfacing Sections
F9-F13	Typical Surfacing Sections
F14-F18	Pavement Slope Layouts
F19-F20	Median Crossovers

Plot Scale - 1:1500

InfrastructureDesignGroup

Plotted From -

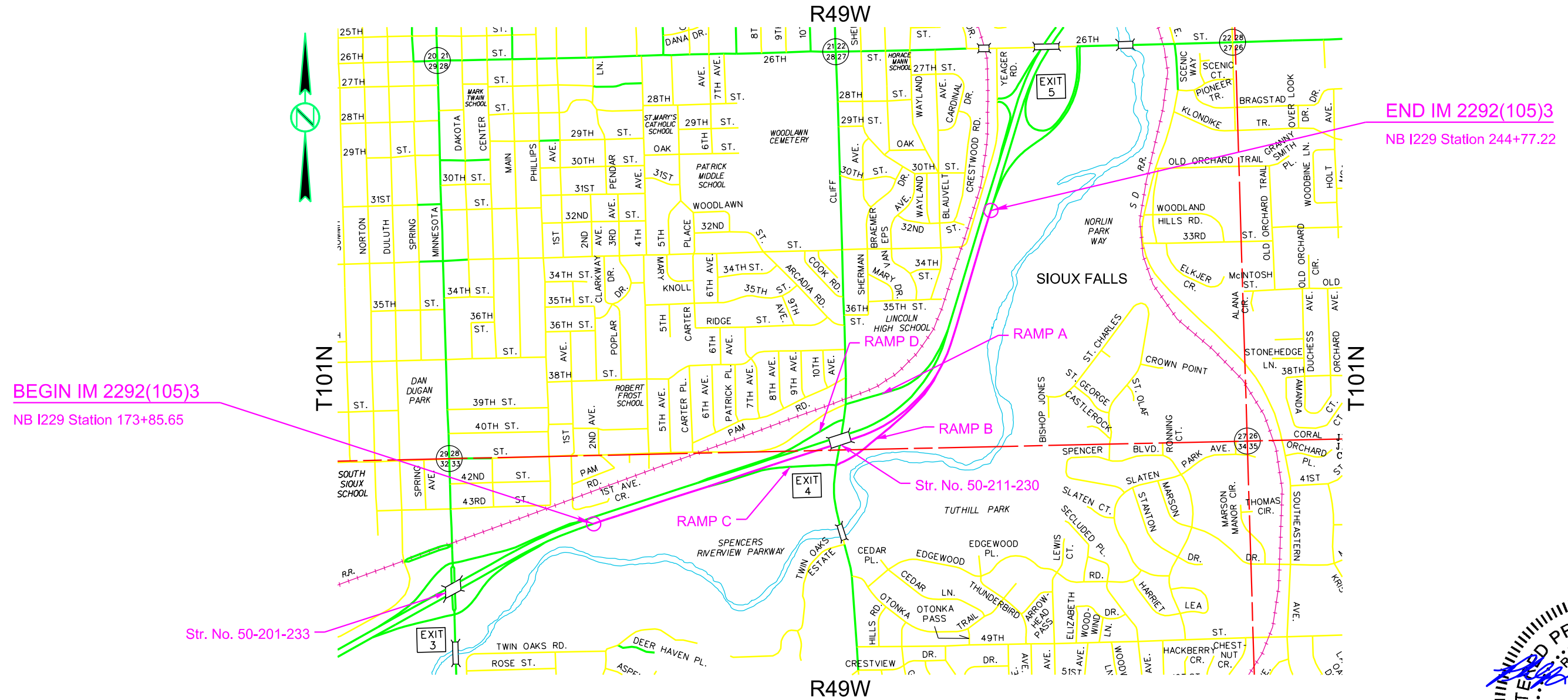

File - ...107\Cvs_SectionF_Title.dgn

SECTION F – ESTIMATE OF QUANTITIES

BID ITEM NUMBER	ITEM	QUANTITY	UNIT
120E6200	Water for Granular Material	132.7	MGal
120E9000	Pit Run	377.9	Ton
260E1010	Base Course	11,055.1	Ton
320E1200	Asphalt Concrete Composite	7,059.6	Ton
332E0010	Cold Milling Asphalt Concrete	1,813	SqYd
380E6450	Saw Joint in PCC Pavement	959.1	Ft
831E0210	Non-woven Separator Fabric	445	SqYd

CONTROL OF ACCESS

If a Contractor's operations would require access to the interstate ROW in any location not currently designated as public access, prior approval must be obtained from the Department. All requests will be reviewed based on safety and construction sequencing. A Contractor will not assume that all requests will be granted.

The Contractor will be responsible for all safety control and signing measures.

Anytime Contractor operations have ceased for the day, any entrances approved in a control of access area will be closed by the Contractor.

The request for access will be provided in writing to the Engineer two weeks in advance of any proposed break in control of access.

COLD MILLING ASPHALT CONCRETE

The Los Angeles Abrasion Loss value on the aggregate used for the in-place asphalt concrete was unknown.

Cold milling asphalt concrete will be done on the median crossover between Exit 3 and Exit 4. The top two inches of the existing asphalt pavement will be milled to allow for additional asphalt concrete composite. Any additional costs associated with this additional cold milling will be incidental to the contract unit price per square yard for "Cold Milling Asphalt Concrete."

Alignment	Location	Station	Cold Milling Asphalt Concrete (SqYd)
I-229 NB	Exit 3-4 Median Crossover	174+55 to 181+03	1,812.9
Total :			1,812.9

SURFACING THICKNESS DIMENSIONS

The plans shown spread rates will be applied even though the thickness may vary from that shown in the plans.

At those locations where material must be placed to achieve a required elevation, the depth/quantity may be varied to achieve the required elevation.

UNCLASSIFIED EXCAVATION

See Section B for total quantity of Unclassified Excavation, Removed Asphalt Mix Material, Removed Granular Material, and Waste Material. See typical sections for locations of these materials.

The Removed Granular Material and Waste Material quantities of the Unclassified Excavation quantity will be as noted in the following table. These Unclassified Excavation quantities will not be measured for payment and the basis of payment will be plans quantity.

The Unclassified Excavation waste material will be used as directed by the Engineer. It may be used as Contractor Furnished Borrow for inslope flattening and widening. The Contractor will ensure no asphalt concrete material will be used for inslope flattening and widening.

GRANULAR MATERIAL, FURNISH

Granular material will be furnished by the Contractor for use in this project.

The granular material will be Base Course meeting the requirements of Section 882.

TABLE OF UNCLASSIFIED EXCAVATION

Location of Removal Areas	Granular material for removal	Waste Material
	CuYd	CuYd
I-229 Outside Shoulder		
Sta 177+72.96 to Sta. 197+40.24 NBL		1,233.2
Sta 216+87.83 to Sta. 219+75.00 NBL	78.5	59.0
Sta 219+75.01 to Sta. 223+50.00 NBL		137.0
Sta 223+50.01 to Sta. 231+25.00 NBL	138.4	294.7
Sta 231+25.01 to Sta. 244+77.22 NBL		770.7
I-229 Inside Shoulder		
Sta 21+08.00 to Sta. 230+25.00 NBL		832.2
NB Diversion		
Sta 5197+40.24 to Sta. 5198+74.50	39.1	31.3
Sta 5198+74.51 to Sta. 5199+16.25	12.2	14.3
Sta 5199+16.26 to Sta. 5208+05.00		423.5
Sta 5209+45.00 to Sta. 5214+37.00		50.2
Sta 5214+37.01 to Sta. 5217+01.00	56.6	105.9
Ramp B		
Sta 20+30.63 to Sta. 22+33.62		14.1
Sta 22+33.63 to Sta. 25+35.87	91.1	27.1
Ramp C		
Sta 32+82.03 to Sta. 34+54.63	47.4	41.9
Sta 34+54.63 to Sta. 36+29.11		50.5
Exit 3-4 Median Crossover		
Exit 3-4 Median Crossover		235.2
Exit 4-5 Median Crossover		45.3
Total :	463.3	4,366.1

PIT RUN MATERIAL

Pit Run material will be obtained from a granular source conforming to Section 120 of the Specifications.

Minimum compaction testing requirements will be one test per crossover location.

SAW JOINT IN PCC PAVEMENT

Prior to the removal of in place asphalt concrete and/or PCC Pavement, the existing pavement will be sawed full depth to a true line with a vertical face. If approved by the Engineer, the Contractor may elect to use a different method to create this vertical face. All costs to saw joint will be incidental to the contract unit price per foot for Saw Joint in PCC Pavement.

JOINT SAWING TABLE

Station		Station	PCC Pavement Joint (feet)
Rt Shoulder			
197+40.2			23.3
197+40.2	to	199+28.8	188.6
199+28.8			9.9
214+26.6			10.2
214+26.6	to	219+75.0	548.4
219+75.0			20.8
219+75.0	to	219+81.6	6.6
219+81.6			4.0
223+48.4			9.4
223+48.4	to	231+26.1	77.7
231+26.1			10.3
Ramp C			
200+41.1	to	200+47.1	24.9
Ramp B			
213+98.3	to	214+04.0	25.0
Total =			959.1

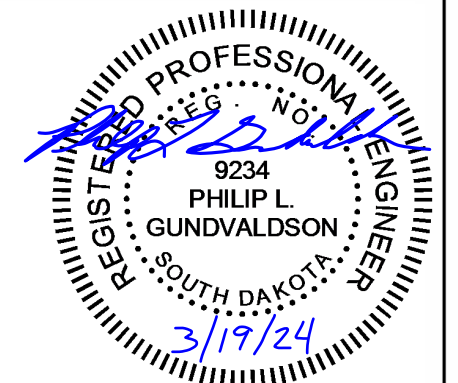

RECYCLED CONCRETE AGGREGATE (RCA)

Portland cement concrete pavement removed from the mainline within the project limits may be crushed and reused as granular material, provided it meets the requirements for the granular material it is replacing.

All in-place rebar will be separated and removed from the RCA.

There is an estimated 1623.1 ton of PCC Pavement on this project that can be crushed and reused. This quantity is based on a unit weight of 118 lbs. per cubic foot for the recycled concrete aggregate.

The Contractor will dispose of the material (including existing rebar) not utilized on the project at a site approved by the Engineer.

Payment for the recycled concrete aggregate will be at the contract unit price per unit per ton for the granular material that it is replacing.

ASPHALT CONCRETE COMPOSITE

Asphalt Concrete Composite will include MC-70 Asphalt for Prime placed at the rate of 0.30 gallons per square yard. The Asphalt for Prime will be applied to the Base Course for the full width of the bottom layer of Asphalt Concrete Composite plus one foot additional on the outside shoulder.

Asphalt for tack SS-1h or CSS-1h will be applied prior to each lift of Asphalt Concrete Composite. Asphalt for tack will be applied at a rate of 0.09 gallons per square yard on existing pavement or milled asphalt concrete surfaces and at a rate of 0.06 gallons per square yard on primed base course or new asphalt concrete pavement. The Asphalt for tack will be applied for the full width of the bottom layer of Asphalt Concrete Composite plus one-half foot additional on the outside shoulder.

Application of flush seal will not be required following the completion of the asphalt concrete surfacing.

EXISTING PCC PAVEMENT

The existing 10.5" Continuously Reinforced P.C.C. Pavement is reinforced with No. 6 Longitudinal deformed steel bars spaced at 6" center-to-center, and No. 4 Transverse deformed steel bars spaced at 48" center-to-center.

The aggregate in the existing Continuously Reinforced P.C.C. Pavement may be quartzite.

NON-WOVEN SEPARATOR FABRIC

Non-woven Separator Fabric has been included in the Estimate of Quantities for the median crossovers. This fabric is to be used as a separator between the Pit Run material and the Base Course to prevent migration of fines from the Base Course into the Pit Run material. If the Pit Run material contains enough fines as placed to prevent the loss of material from the Base Course, the separator fabric may be eliminated by CCO.

Table of Non-Woven Separator Fabric provided below:

Location	Non-woven Separator Fabric
	SqYds
Median Crossovers	
Exit 3-4 Crossover	389.9
Exit 4-5 Crossover	55.5
Totals	445.4

Non-woven Separator Fabric will be paid for at the contract unit price per square yard of fabric placed. Payment for this item will be full payment for furnishing all equipment, labor and incidentals required to furnish and install the fabric.

TABLE OF QUANTITIES

Location	Description	WATER FOR GRANULAR MATERIAL MGal	BASE COURSE Ton	PIT RUN MATERIAL Ton	ASPHALT CONCRETE COMPOSITE		
					1st Lift (3 in) Ton	2nd Lift (3 in) Ton	Top Lift (2 in) Ton
I-229 Outside Shoulder							
177+73.0 to 197+40.2		21.1	1761.6		213.4	213.4	142.3
216+87.8 to 219+75.0		10.5	871.6		211.3	211.3	140.9
219+75.0 to 223+50.0		3.8	314.0		24.1	24.1	16.1
223+50.0 to 231+25.0		13.6	1133.4		198.8	198.8	132.5
231+25.0 to 244+77.2		14.8	1235.3		141.3	141.3	94.2
I-229 Inside Shoulder							
177+73.0 to 197+40.2		4.9	408.4		126.6	126.6	84.4
NB Diversion							
5197+40.2 to 5198+74.5		3.9	323.5		100.3	100.3	66.9
5198+74.5 to 5199+16.3		0.9	71.4		22.2	22.2	14.8
5199+16.3 to 5208+05.0		23.7	1970.9		611.0	611.0	407.4
5209+45.0 to 5214+37.0		16.7	1393.2		431.9	431.9	288.0
5124+37.0 to 5127+01.0		7.2	603.3		187.1	187.1	124.7
Ramp B							
20+30.6 to 22+33.6		0.7	56.0		17.4	17.4	11.6
22+33.6 to 25+35.9		4.7	395.5		122.6	122.6	81.8
Ramp C							
32+82.0 to 34+54.6		2.7	222.9		69.1	69.1	46.1
34+54.6 to 36+29.1		0.5	43.4		13.5	13.5	9.0
Median Crossover							
173+85.7 to 177+03.8	Extension	2.6	219.4	216.9	68.0	68.0	45.4
174+55.0 to 181+03.0	Overlay						210.4
243+68.7 to 244+34.7	Extension	0.4	31.3	161.0	9.7	9.7	6.5
Total :		132.7	11,055.1	377.9	7,059.6		

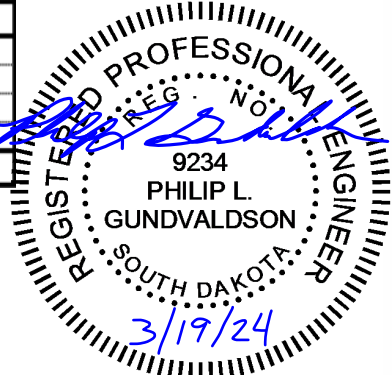

IN PLACE SURFACING SECTIONS



FOR BIDDING PURPOSES ONLY

STATE OF SOUTH DAKOTA	PROJECT IM 2292(105)3	SHEET NO. F4	TOTAL SHEETS F20
-----------------------	--------------------------	-----------------	---------------------

Plotting Date: 03/01/2024

I-229 NB Lanes

Sta. 177+72.86 to Sta. 197+40.24
Sta. 231+26.14 to Sta. 244+77.22

-  Remove Granular Base Material
-  Unclassified Excavation (waste material)
-  PCC Pavement Removal

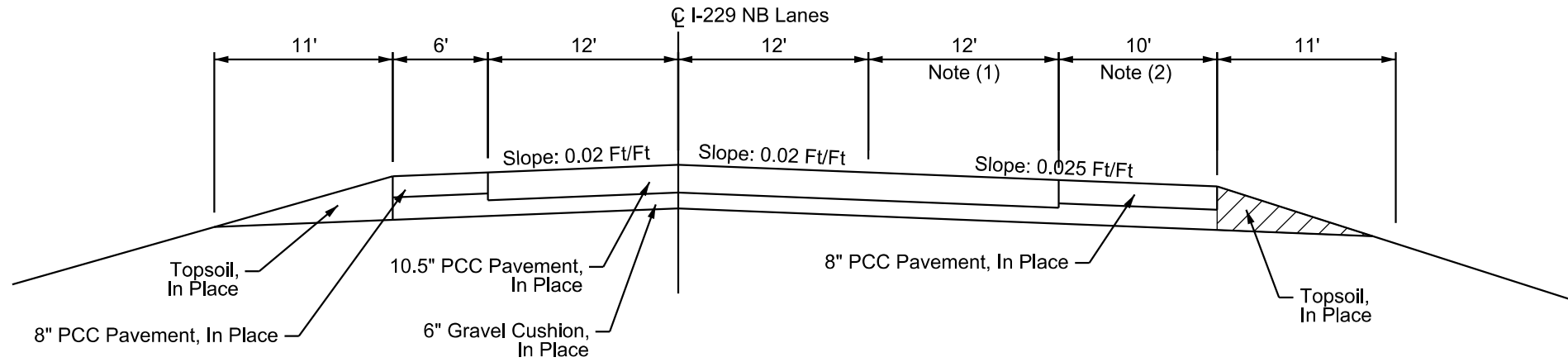

Note:

- (1) 12' to 19.5' from STA 195+89.08 to STA 197+40.24
- (2) 10' to 4' from STA 195+89.08 to STA 197+40.24

I-229 NB Lanes

Sta. 197+40.24 to Sta. 198+61.19

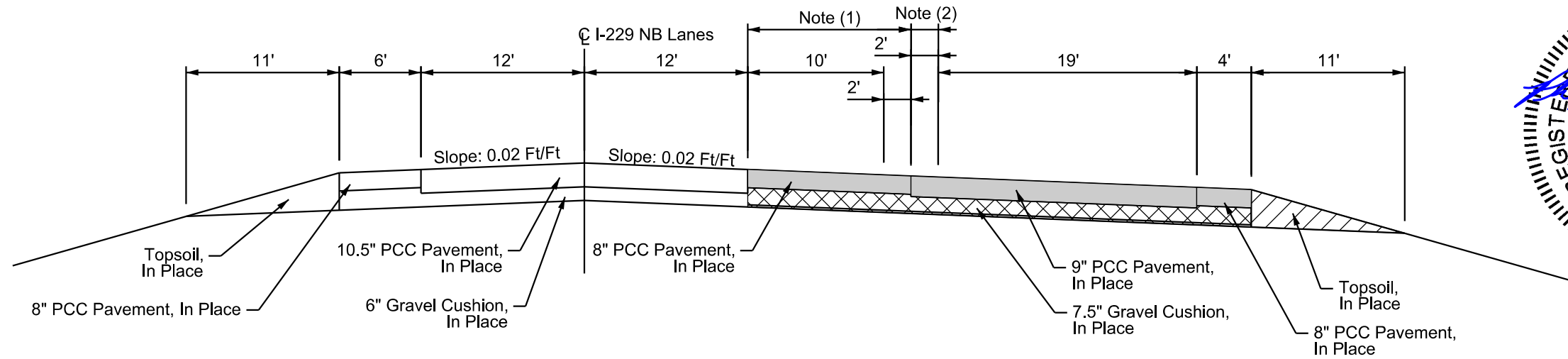

Note:

- (1) 0' to 12' from STA 197+55.91 to STA 198+61.19
- (2) 0' to 2' from STA 197+40.24 to STA 197+55.91



Plot Scale - 1:10

InfrastructureDesignGroup

Plotted From -

File - ...107CYS_SectionF_In-Place-Surfacing-Sections.dgn

IN PLACE SURFACING SECTIONS



FOR BIDDING PURPOSES ONLY

STATE OF SOUTH DAKOTA	PROJECT IM 2292(105)3	SHEET NO. F5	TOTAL SHEETS F20
-----------------------	--------------------------	-----------------	---------------------

Plotting Date: 03/01/2024

I-229 NB Lanes

Sta. 198+61.19 to Sta. 217+36.73

-  Remove Granular Base Material
-  Unclassified Excavation (waste material)
-  PCC Pavement Removal

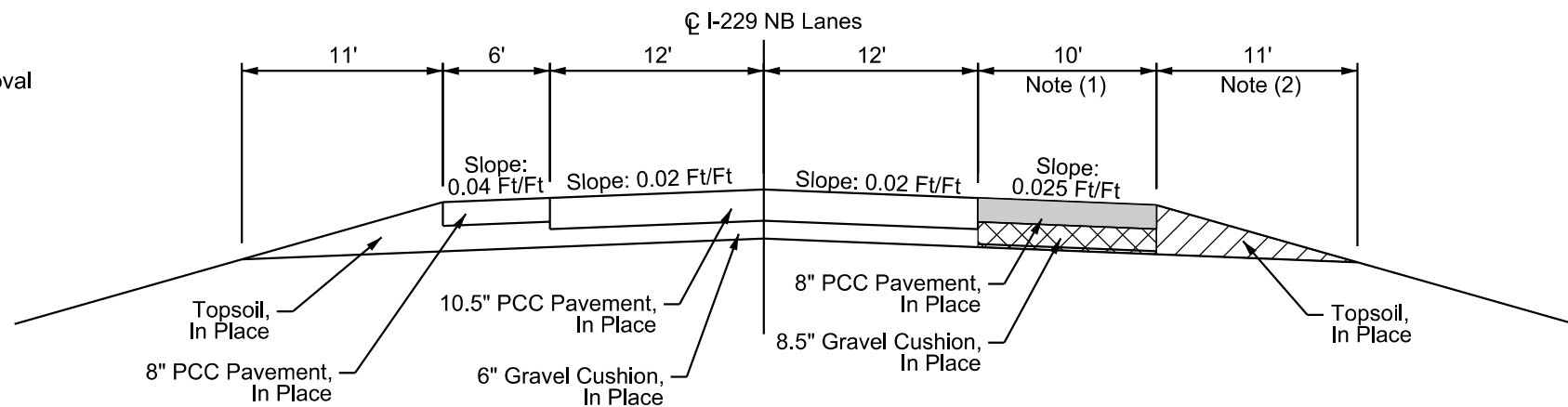

Note:

- (1) Concrete Removal is from Sta. 198+61.19 to Sta. 199+28.84
Concrete Removal is from Sta. 214+26.48 to Sta. 217.36.73
- (2) Shoulder Removal is from Sta. 199+28.84 to Sta. 204+49.44
Shoulder Removal is from Sta. 213+26.24 to Sta. 214+26.48

I-229 NB Lanes

Sta. 217+36.73 to Sta. 219+81.60

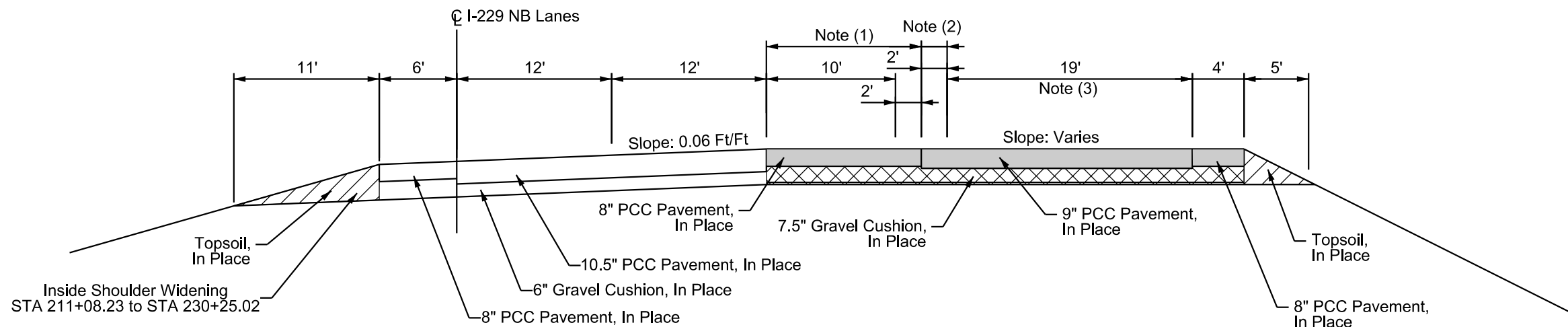

Note:

- (1) 12' to 0' from STA 217+36.73 to STA 219+69.83
- (2) 2' to 1.77' from STA 219+69.83 to STA 219+81.60
- (3) Removal Ends at STA 219+75.00

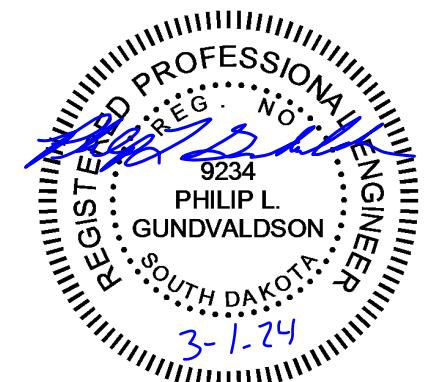

Plot Scale - 1:10

InfrastructureDesignGroup

Plotted From -



File - ...107CVs_SectionF_In-Place-Surfacing-Sections.dgn

IN PLACE SURFACING SECTIONS

FOR BIDDING PURPOSES ONLY

STATE OF SOUTH DAKOTA	PROJECT IM 2292(105)3	SHEET NO. F6	TOTAL SHEETS F20
-----------------------	--------------------------	-----------------	---------------------

Plotting Date: 03/01/2024

-  Remove Granular Base Material
-  Unclassified Excavation (waste material)
-  PCC Pavement Removal

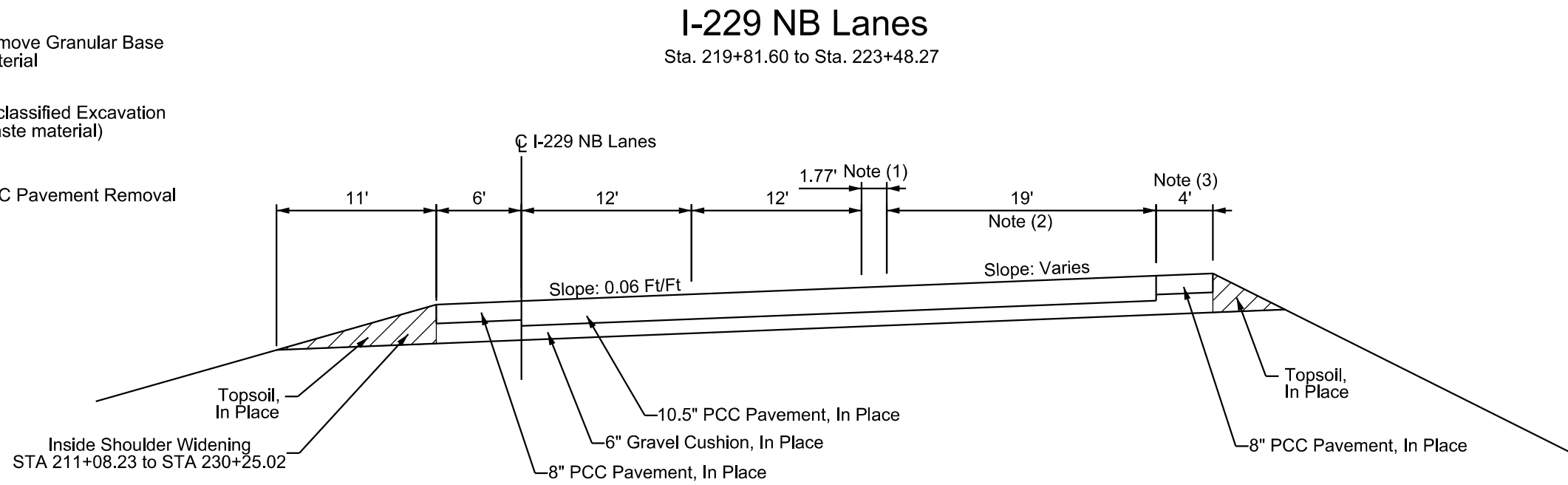

Note:

- (1) 1.77' to 0' from STA 219+81.60 to STA 220+42.58
- (2) 19' to 12' from STA 219+81.60 to STA 223+48.27
- (3) 4' to 10' from STA 219+81.60 to STA 223+48.27

I-229 NB Lanes

Sta. 223+48.27 to Sta. 231+26.14

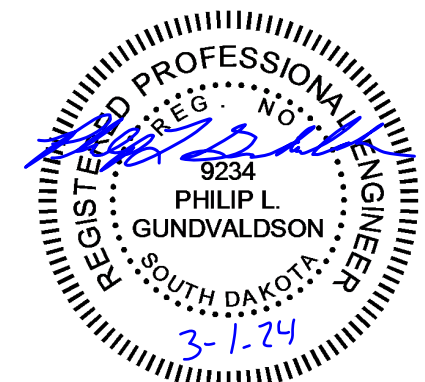
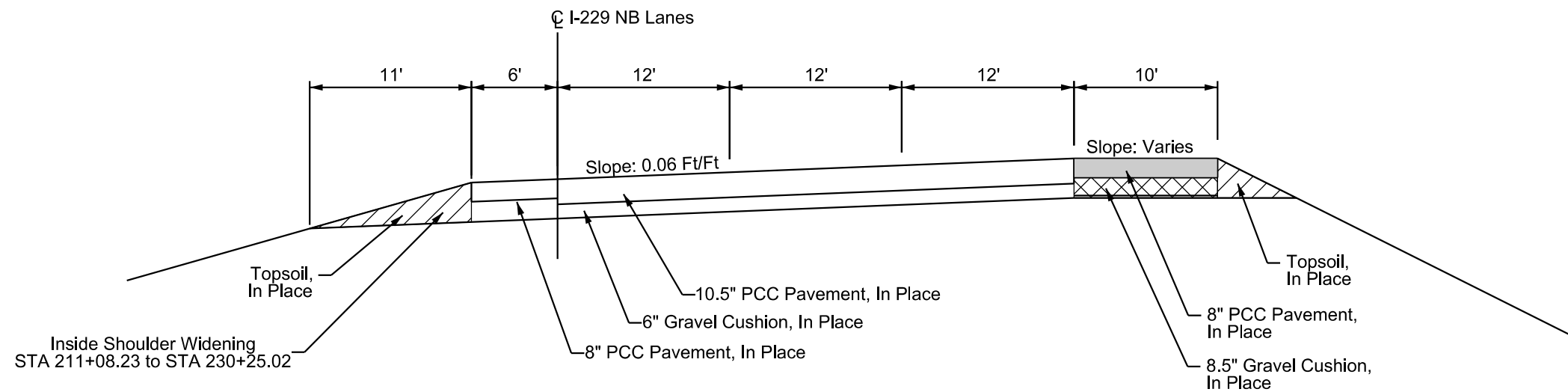

Plot Scale - 1:10

InfrastructureDesignGroup

Plotted From -

File - ...107CYS_SectionF_In-Place-Surfacing-Sections.dgn

IN PLACE SURFACING SECTIONS



FOR BIDDING PURPOSES ONLY

STATE OF SOUTH DAKOTA	PROJECT	SHEET NO.	TOTAL SHEETS
	IM 2292(105)3	F7	F20

Plotting Date: 03/01/2024

I229 RAMP C

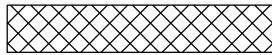
Sta. 32+82.03 to Sta. 34+54.63

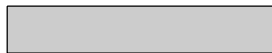
-  Remove Granular Base Material
-  Unclassified Excavation (waste material)
-  PCC Pavement Removal

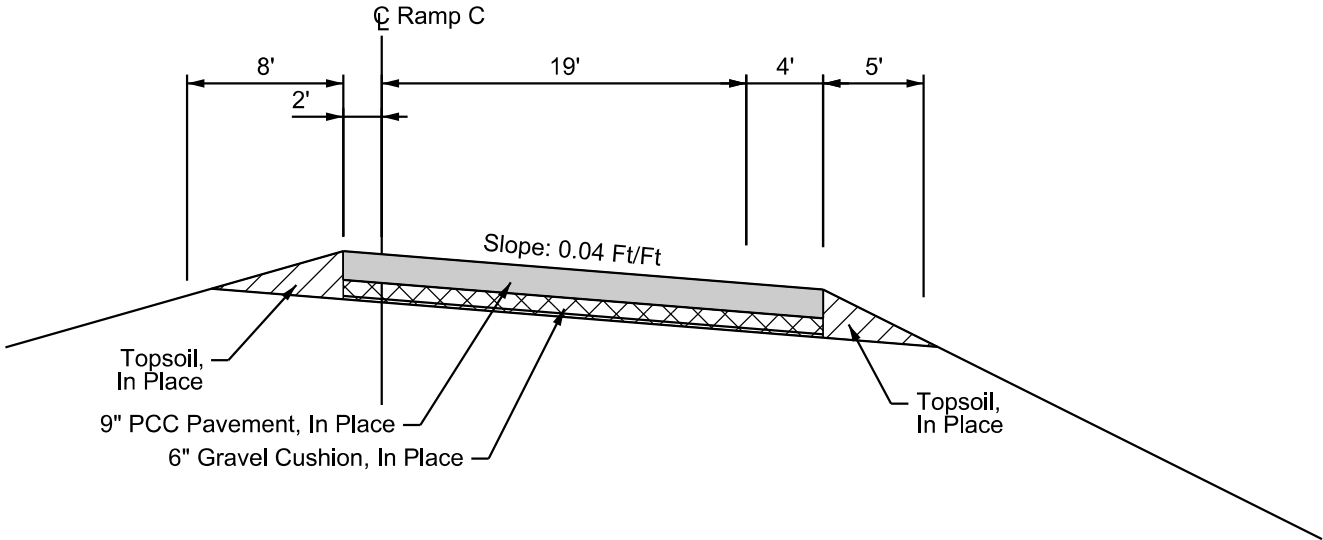

I229 RAMP C

Sta. 34+54.63 to Sta. 36+29.11

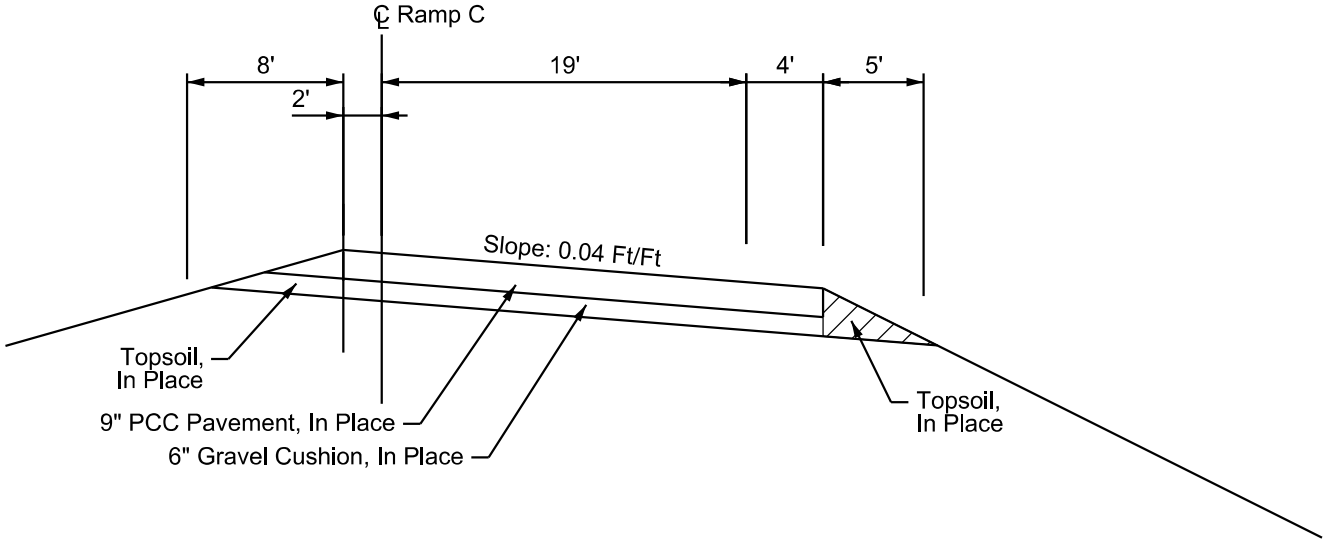

Plot Scale - 1:10

InfrastructureDesignGroup

Plotted From -

File - ...107CYs_SectionF_In-Place-Surfacing-Sections.dgn



IN PLACE SURFACING SECTIONS

FOR BIDDING PURPOSES ONLY

STATE OF SOUTH DAKOTA	PROJECT IM 2292(105)3	SHEET NO. F8	TOTAL SHEETS F20
-----------------------	--------------------------	-----------------	---------------------

Plotting Date: 03/01/2024

Plot Scale - 1:10

-  Remove Granular Base Material
-  Unclassified Excavation (waste material)
-  PCC Pavement Removal

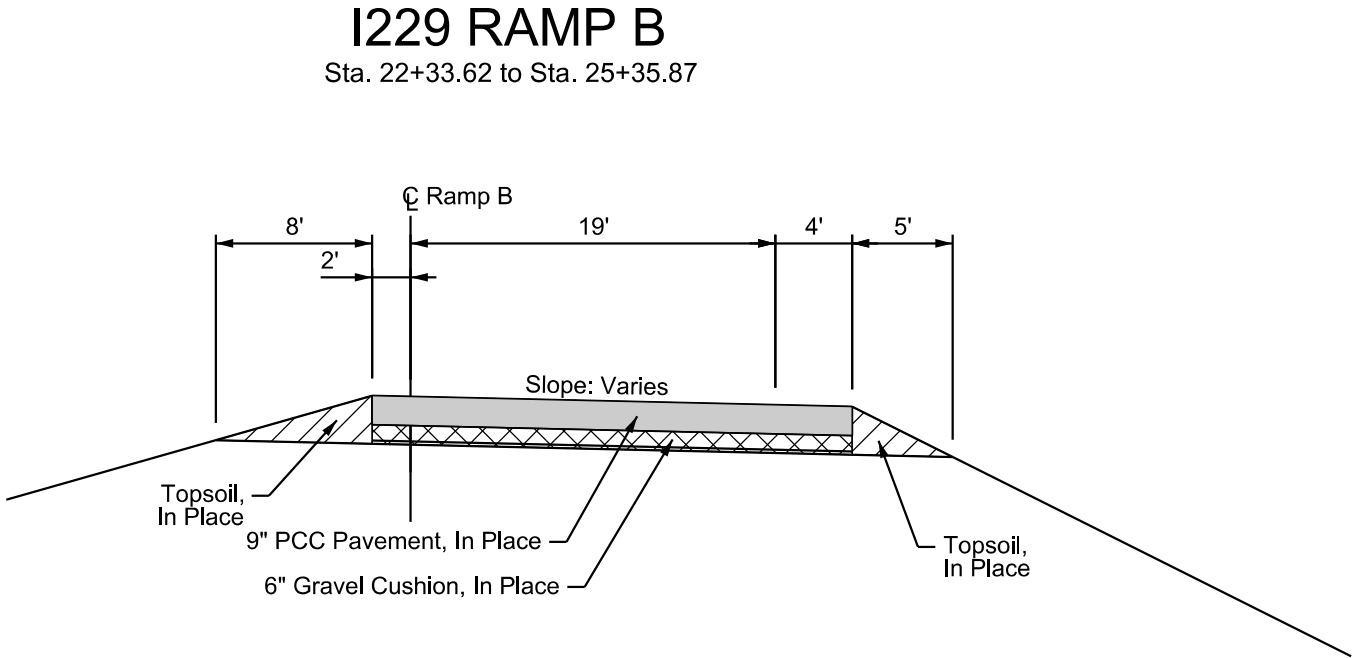
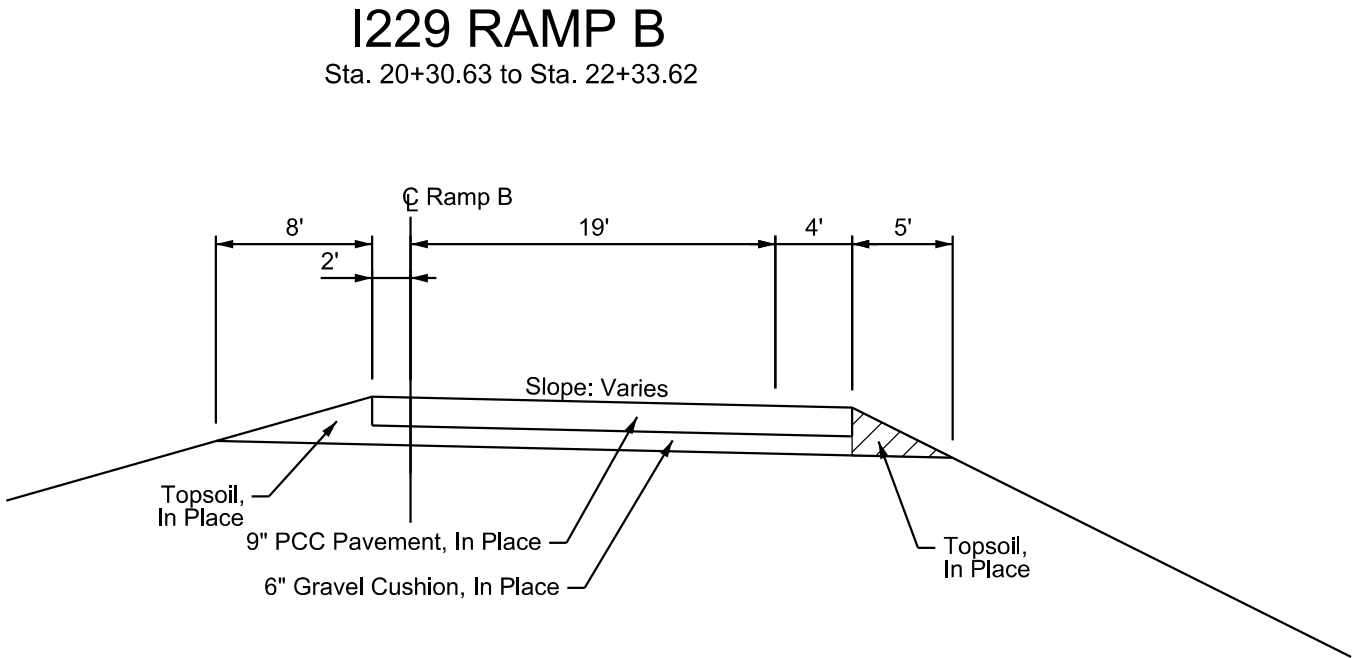

Plotted From - InfrastructureDesignGroup

File - ...107CVs_SectionF_In-Place-Surfacing-Sections.dgn



TYPICAL SURFACING SECTIONS

FOR BIDDING PURPOSES ONLY

STATE OF SOUTH DAKOTA	PROJECT IM 2292(105)3	SHEET NO. F9	TOTAL SHEETS F20
-----------------------	-----------------------	--------------	------------------

Plotting Date: 03/01/2024

I-229 NB Lanes

Sta. 177+72.86 to Sta. 197+40.24
Sta. 231+26.14 to Sta. 244+77.22

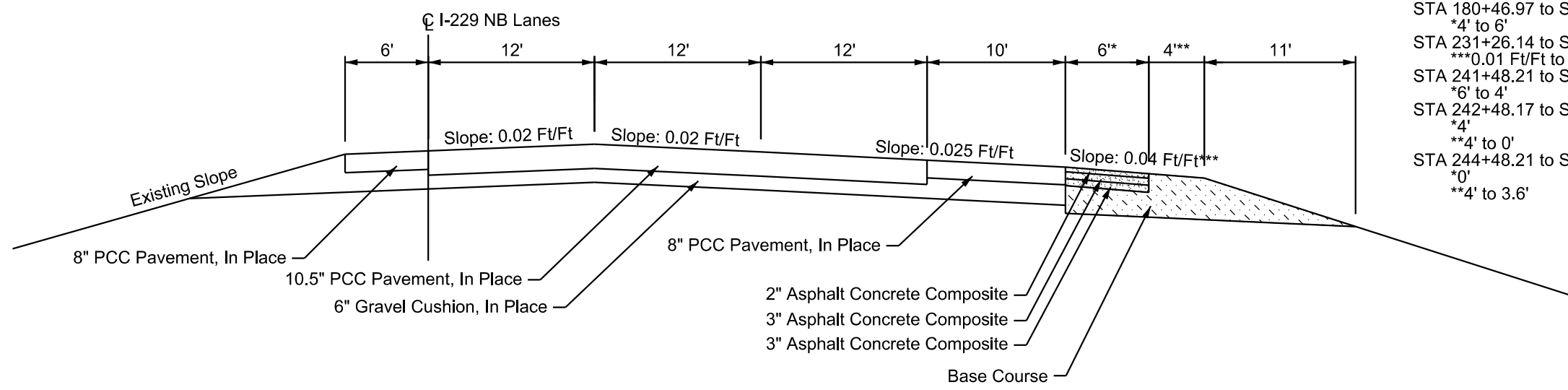

- Transitions**
- STA 177+72.86 to STA 178+46.93
*0'
 - **2.5' to 4'
 - STA 178+46.93 to STA 180+46.97
*4'
 - **0' to 4'
 - STA 180+46.97 to STA 181+47.00
*4' to 6'
 - STA 231+26.14 to STA 232+37.14
***0.01 Ft/Ft to 0.04 Ft/Ft
 - STA 241+48.21 to STA 242+48.17
*6' to 4'
 - STA 242+48.17 to STA 244+48.21
*4'
 - **4' to 0'
 - STA 244+48.21 to STA 244+77.22
*0'
 - **4' to 3.6'

I-229 NB Lanes

Sta. 216+87.83 to Sta. 231+26.14

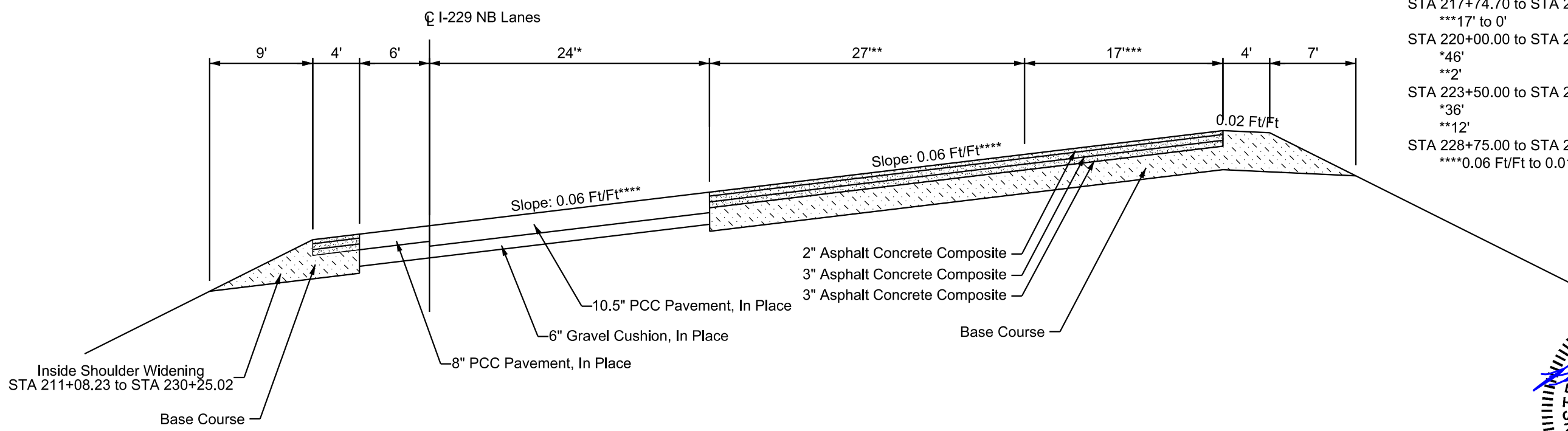

- Transitions**
- STA 216+87.83 to STA 220+00.00
* 24'
 - STA 216+87.83 to STA 217+74.70
**27' to 21'
 - ***17'
 - STA 217+74.70 to STA 220+00.00
**21'
 - STA 217+74.70 to STA 221+53.93
***17' to 0'
 - STA 220+00.00 to STA 223+50.00
*46'
 - **2'
 - STA 223+50.00 to STA 231+25.00
*36'
 - **12'
 - STA 228+75.00 to STA 231+25.00
***0.06 Ft/Ft to 0.01 Ft/Ft



Plotted From: InfrastructureDesignGroup 1:10

File: ...107\Cvs_SectionF_TypicalSurfacing-Sections.dgn

TYPICAL SURFACING SECTIONS

FOR BIDDING PURPOSES ONLY

STATE OF SOUTH DAKOTA	PROJECT IM 2292(105)3	SHEET NO. F10	TOTAL SHEETS F20
-----------------------	--------------------------	------------------	---------------------

Plotting Date: 03/01/2024

I229 RAMP C

Sta. 32+82.03 to Sta. 34+54.63

Transitions
STA 34+16.03 to STA 34+54.63
* 4' to 4.87'

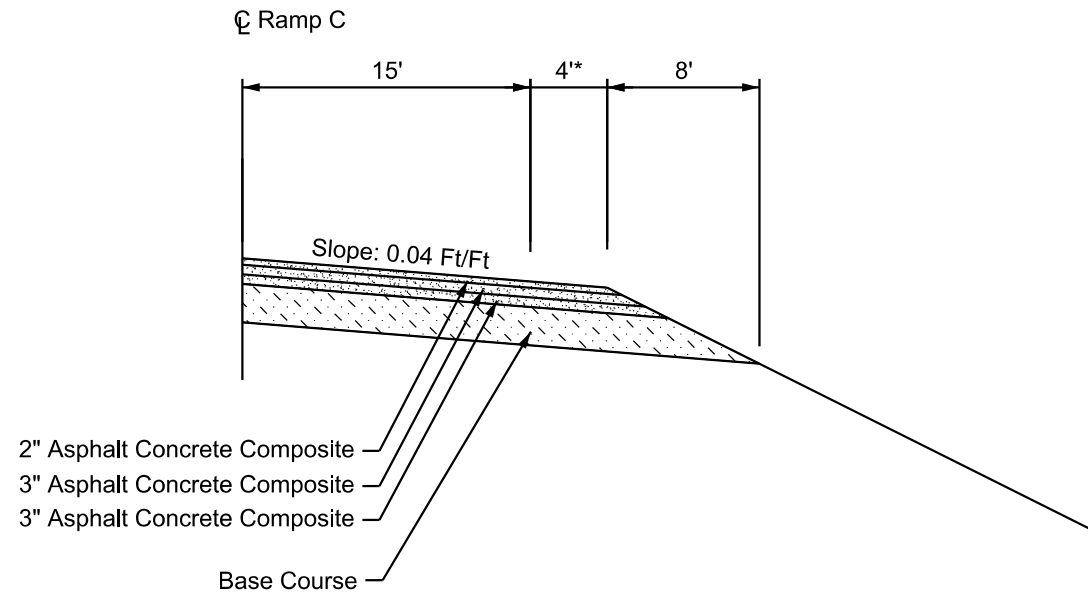

I229 RAMP C

Sta. 34+54.63 to Sta. 36+29.11

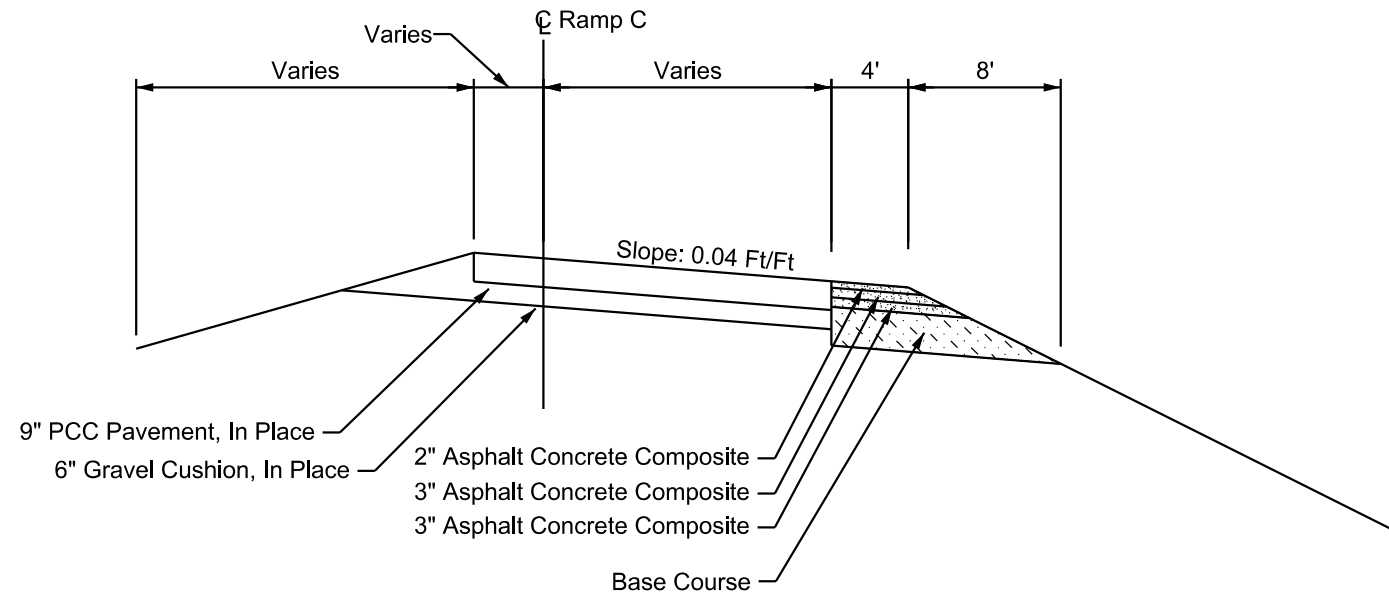

TYPICAL SURFACING SECTIONS

FOR BIDDING PURPOSES ONLY

STATE OF SOUTH DAKOTA	PROJECT IM 2292(105)3	SHEET NO. F11	TOTAL SHEETS F20
-----------------------	--------------------------	------------------	---------------------

Plotting Date: 03/01/2024

I229 NB DIVERSION

Sta. 5197+40.24 to Sta. 5199+15.98

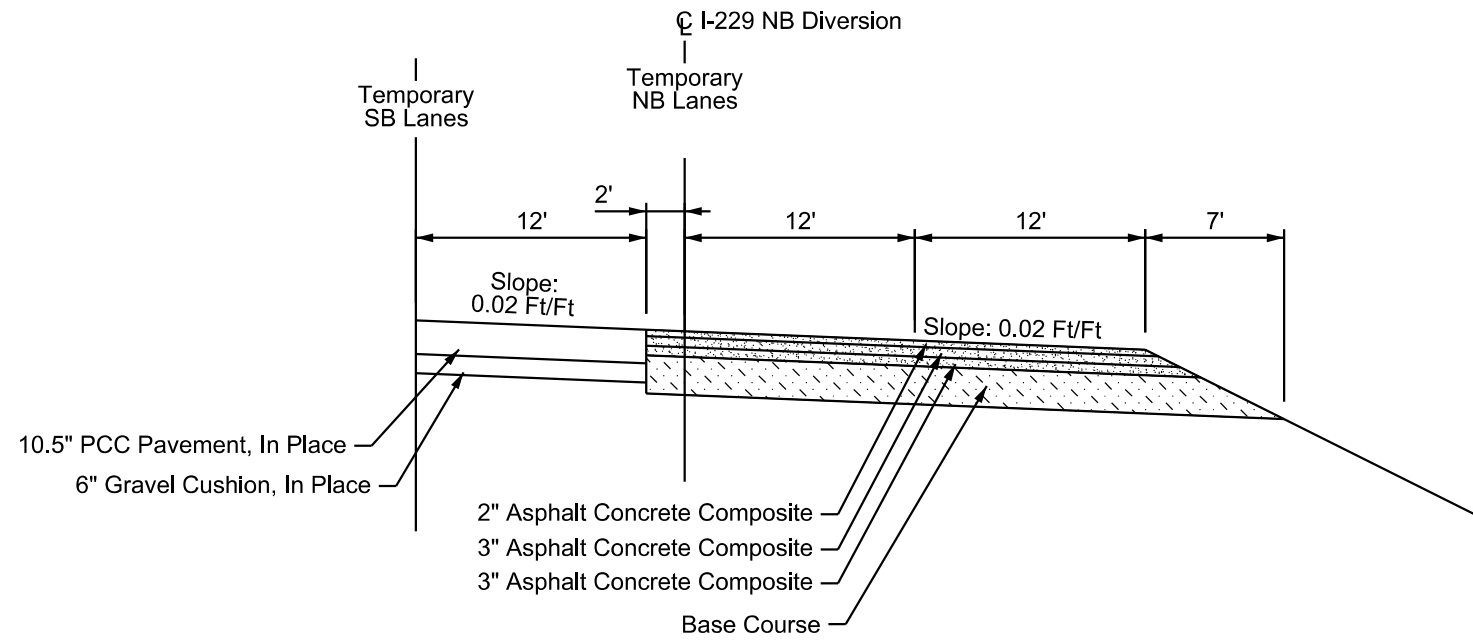

I229 NB DIVERSION

Sta. 5199+15.98 to Sta 5202+72.41

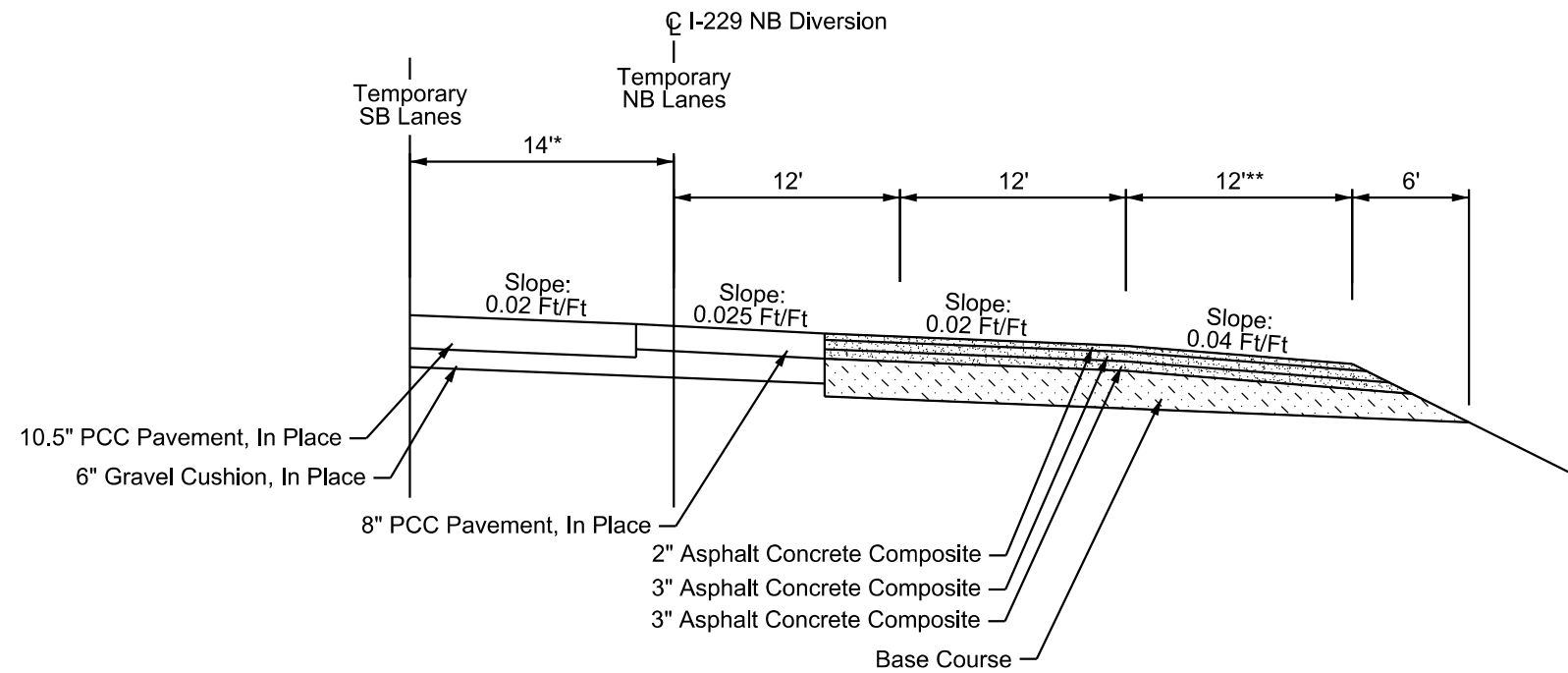

Transitions
 STA 5199+62.83 to STA 5202+72.41
 *14' to 22'
 STA 5199+18.45 to STA 5200+02.99
 **0' to 12'



Plot Scale - 1:10

InfrastructureDesignGroup

Plotted From -

File - ...107\CYS_SectionF_TypicalSurfacing-Sections.dgn

TYPICAL SURFACING SECTIONS

FOR BIDDING PURPOSES ONLY

STATE OF SOUTH DAKOTA	PROJECT IM 2292(105)3	SHEET NO. F12	TOTAL SHEETS F20
-----------------------	--------------------------	------------------	---------------------

Plotting Date: 03/01/2024

I229 NB DIVERSION

Sta. 5202+72.41 to Sta. 5212+19.86

Transitions
 STA 211+08.23 to STA 212+15.28 (I-229 NB Alignment)
 *0' to 2.14'
 STA 5209+31.86 to STA 5212+19.86
 ** -0.02 Ft/Ft to 0.06 Ft/Ft
 STA 5211+55.86 to STA 5212+19.86
 *** -0.04 Ft/Ft to -0.02 Ft/Ft

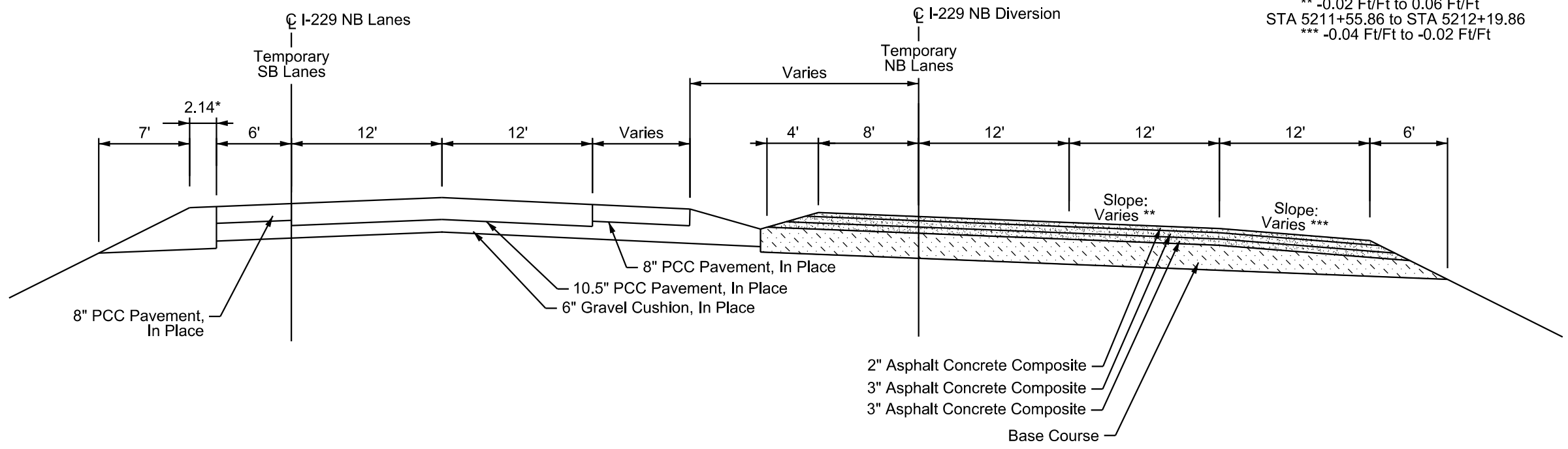

I229 NB DIVERSION

Sta. 5212+19.86 to Sta. 5217+01.32

Transitions
 STA 211+15.28 to STA 213+08.30 (I-229 NB Alignment)
 *2.14' to 4.0'

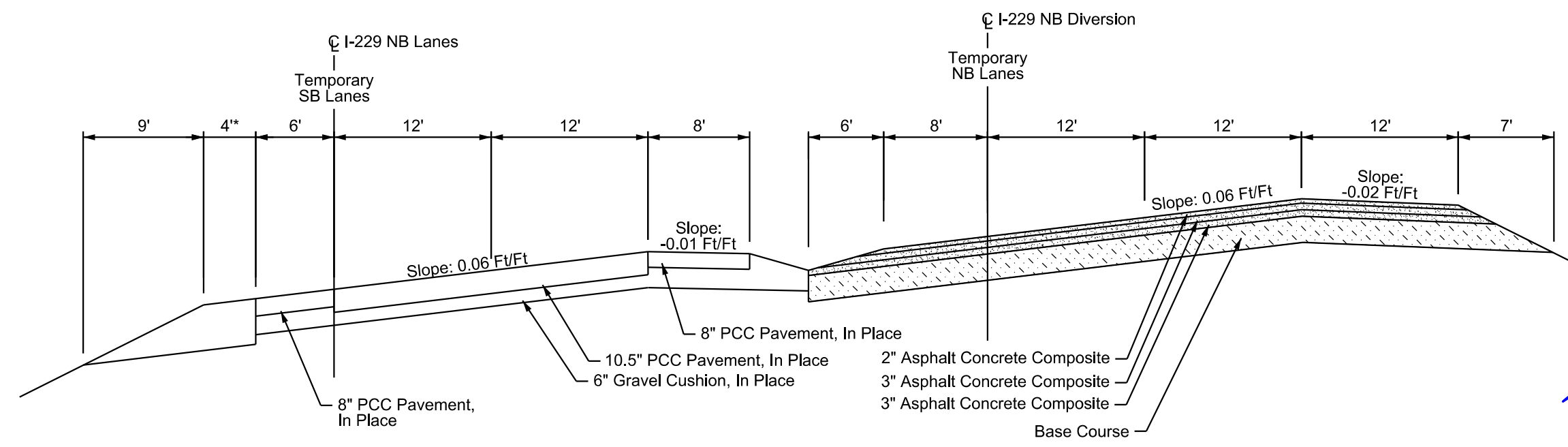

Plot Scale - 1:10

InfrastructureDesignGroup

Plotted From -

File - ...107\CYS_SectionF_TypicalSurfacing-Sections.dgn

TYPICAL SURFACING SECTIONS

FOR BIDDING PURPOSES ONLY

STATE OF SOUTH DAKOTA	PROJECT	SHEET NO.	TOTAL SHEETS
	IM 2292(105)3	F13	F20

Plotting Date: 03/01/2024

I229 RAMP B

Sta. 20+30.63 to Sta. 22+33.62

Transitions

STA 21+66.63 to STA 22+33.62
*4' to 6'

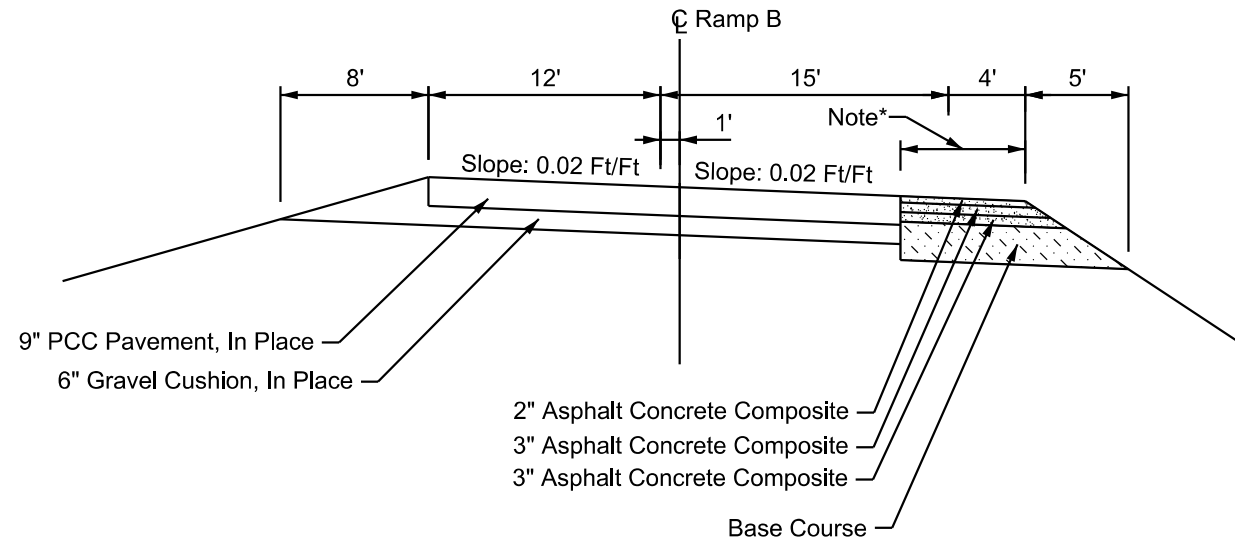

I229 RAMP B

Sta. 22+33.62 to Sta. 25+35.87

Transitions

STA 22+33.62 to STA 25+35.87
*-0.02 Ft/Ft to 0.06 Ft/Ft

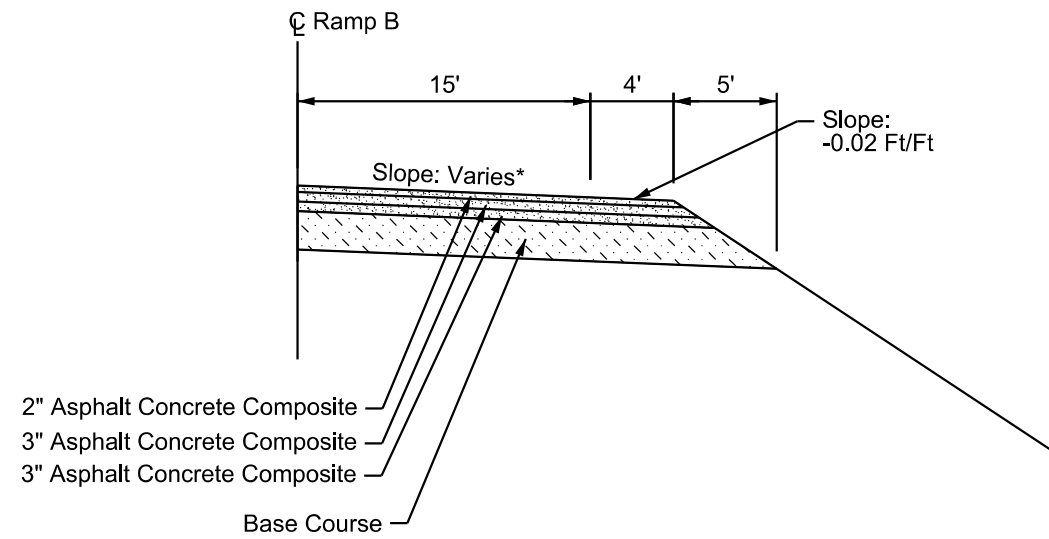

Plot Scale - 1:10

InfrastructureDesignGroup

Plotted From -

File - ...107CYS_SectionF_TypicalSurfacing-Sections.dgn





PAVEMENT SLOPE LAYOUT

FOR BIDDING PURPOSES ONLY

STATE OF SOUTH DAKOTA	PROJECT	SHEET NO.	TOTAL SHEETS
	IM 2292(105)3	F14	F20

Plotting Date: 03/01/2024

I229 NB & SB

-  Paving Area
-  Pavement Slope Transition

Plot Scale -
1:100

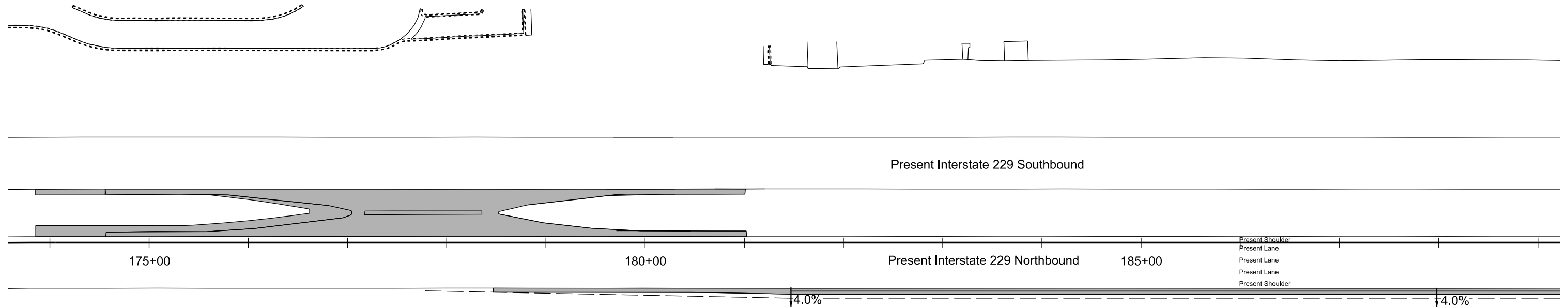
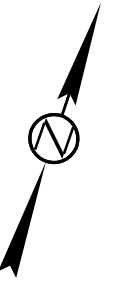

InfrastructureDesignGroup

Plotted From -

File - ...107CYs_SectionF_PavementSlope-Layout.dgn





PAVEMENT SLOPE LAYOUT

FOR BIDDING PURPOSES ONLY

STATE OF SOUTH DAKOTA	PROJECT	SHEET NO.	TOTAL SHEETS
	IM 2292(105)3	F15	F20

Plotting Date: 03/01/2024

I229 NB & SB

-  Paving Area
-  Pavement Slope Transition

Plot Scale -
1:100

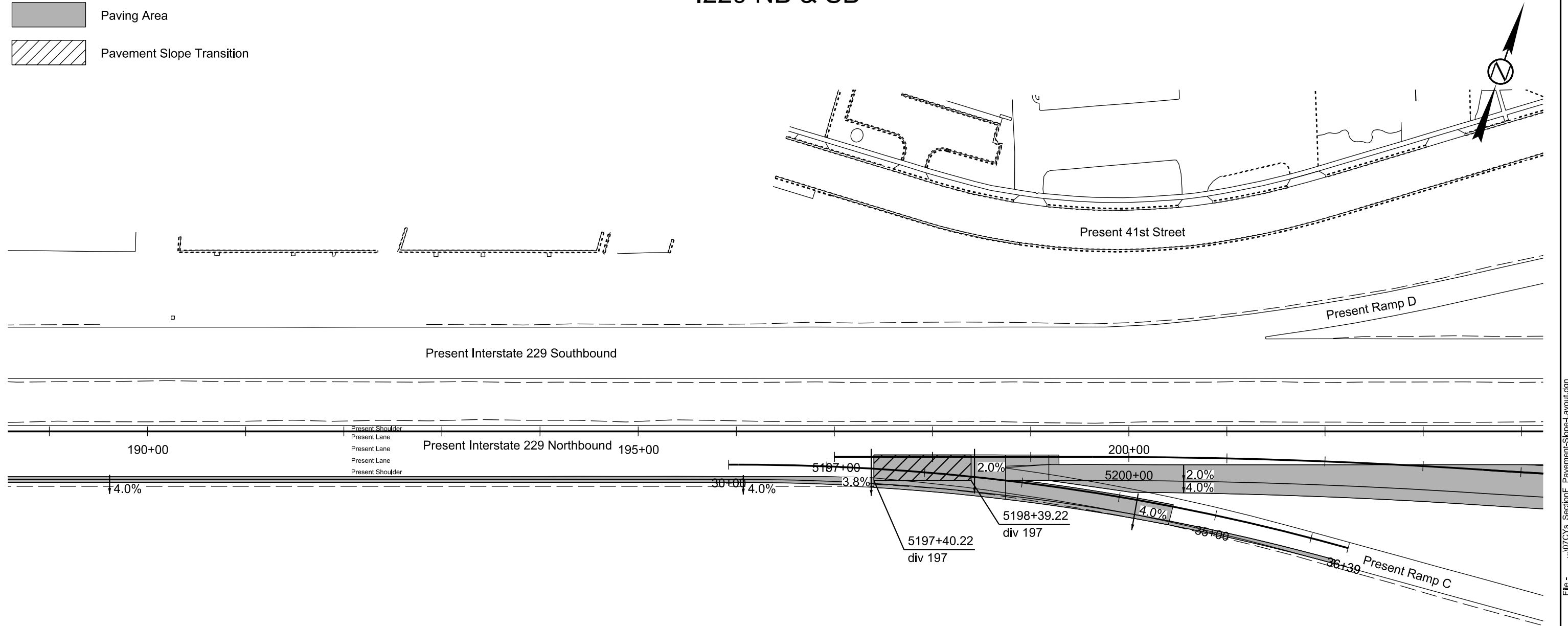

InfrastructureDesignGroup

Plotted From -

File - ...107CVs_SectionF_PavementSlope-Layout.dgn





PAVEMENT SLOPE LAYOUT

FOR BIDDING PURPOSES ONLY

I229 NB & SB

STATE OF SOUTH DAKOTA	PROJECT	SHEET NO.	TOTAL SHEETS
	IM 2292(105)3	F16	F20

Plotting Date: 03/01/2024

-  Paving Area
-  Pavement Slope Transition

Plot Scale - 1:100

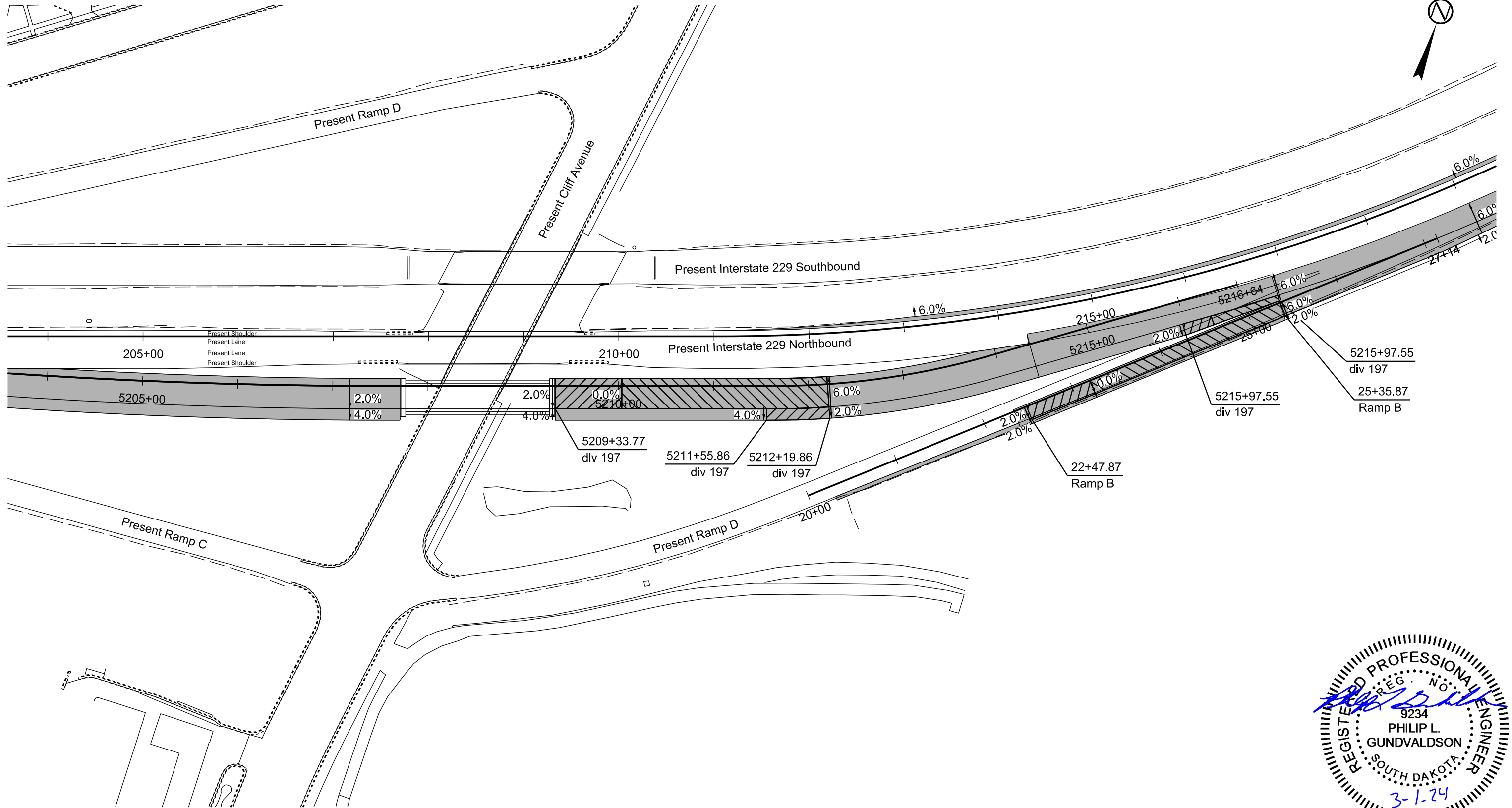
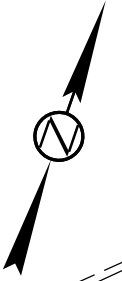

InfrastructureDesignGroup

Plotted From -

File - ...107CYs_SectionF_PavementSlope-Layout.dgn



PAVEMENT SLOPE LAYOUT



FOR BIDDING PURPOSES ONLY

I229 NB & SB

STATE OF SOUTH DAKOTA	PROJECT IM 2292(105)3	SHEET NO. F17	TOTAL SHEETS F20
-----------------------	--------------------------	------------------	---------------------

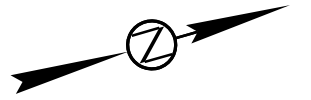
Plotting Date: 03/01/2024



-  Paving Area
-  Pavement Slope Transition

Plot Scale -
1:100

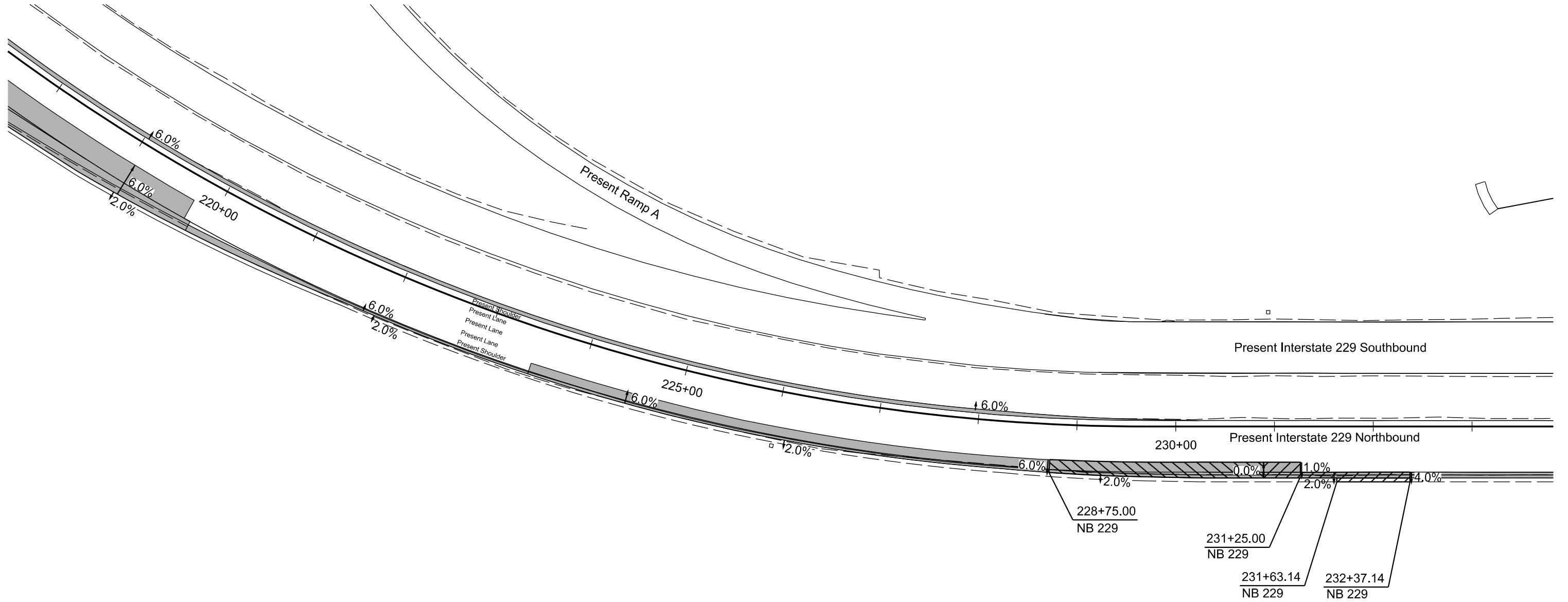

InfrastructureDesignGroup

Plotted From -

File - ...107CVs_SectionF_PavementSlope-Layout.dgn





PAVEMENT SLOPE LAYOUT

FOR BIDDING PURPOSES ONLY

I229 NB & SB

STATE OF SOUTH DAKOTA	PROJECT	SHEET NO.	TOTAL SHEETS
	IM 2292(105)3	F18	F20

Plotting Date: 03/01/2024

-  Paving Area
-  Pavement Slope Transition

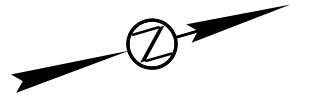

Plot Scale -
1:100

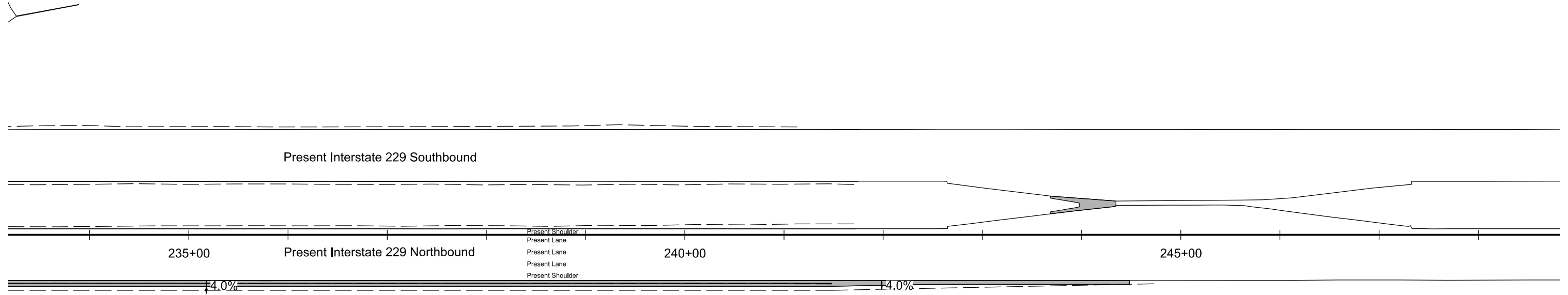

InfrastructureDesignGroup

Plotted From -

File - ...107CYs_SectionF_PavementSlope-Layout.dgn





MEDIAN CROSSOVER FOR BIDDING PURPOSES ONLY

I-229 Exit 3 & 4 Crossover Extension

STATE OF SOUTH DAKOTA	PROJECT IM 2292(105)3	SHEET NO. F19	TOTAL SHEETS F20
-----------------------	--------------------------	------------------	---------------------

Plotting Date: 03/01/2024

-  2" Cold Milling Asphalt Concrete
-  8" Surfacing Area

Plot Scale - 1:60

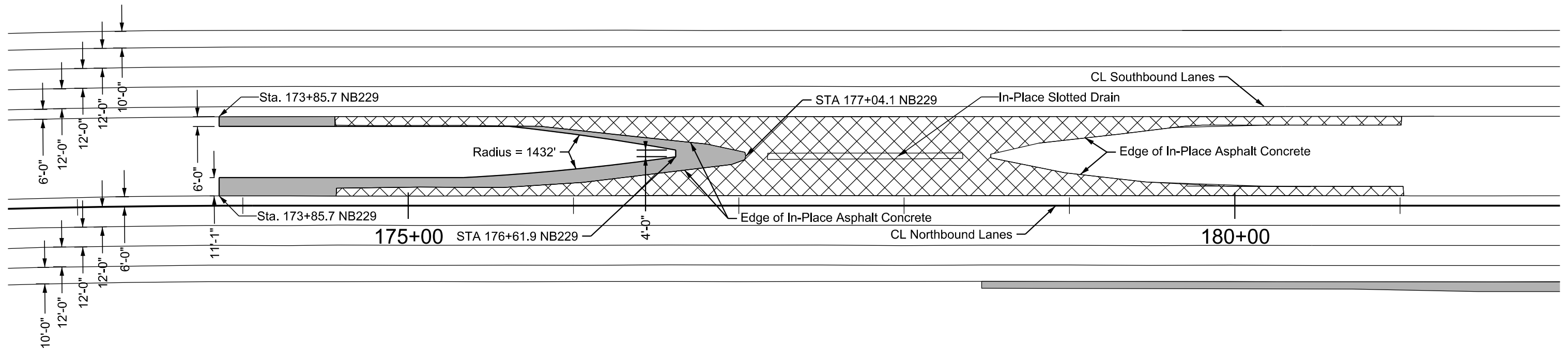

Typical Median Crossover

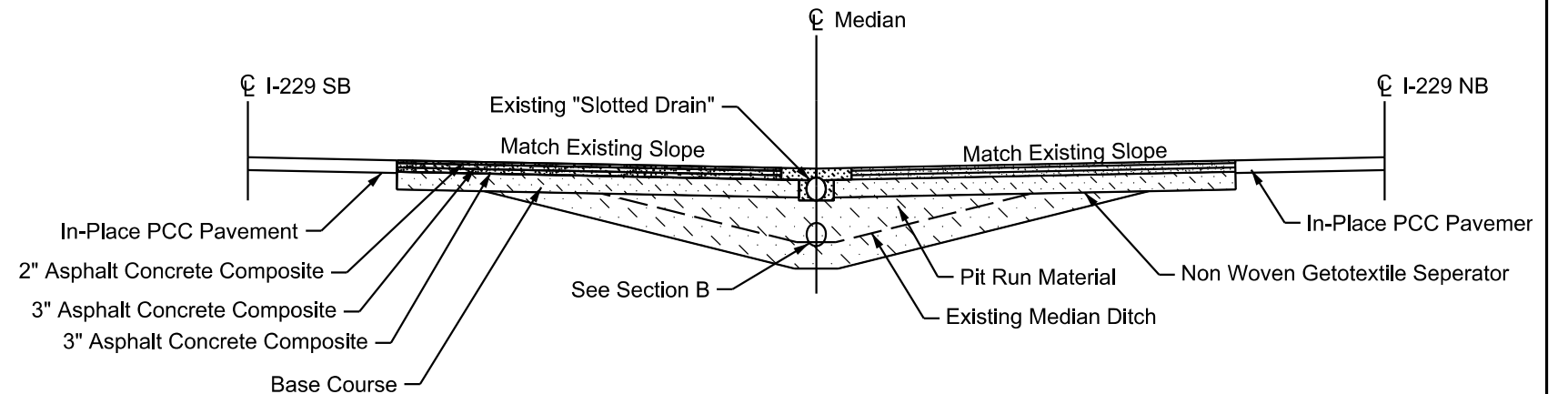

Plotted From - InfrastructureDesignGroup

File - ...107\Cys_SectionF_Crossover-Extensions.dgn

MEDIAN CROSSOVER FOR BIDDING PURPOSES ONLY

I-229 Exit 4 & 5 Crossover Extension

STATE OF SOUTH DAKOTA	PROJECT IM 2292(105)3	SHEET NO. F20	TOTAL SHEETS F20
-----------------------	--------------------------	------------------	---------------------

Plotting Date: 03/01/2024

8" Surfacing Area

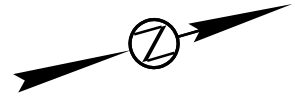

Plot Scale - 1:60

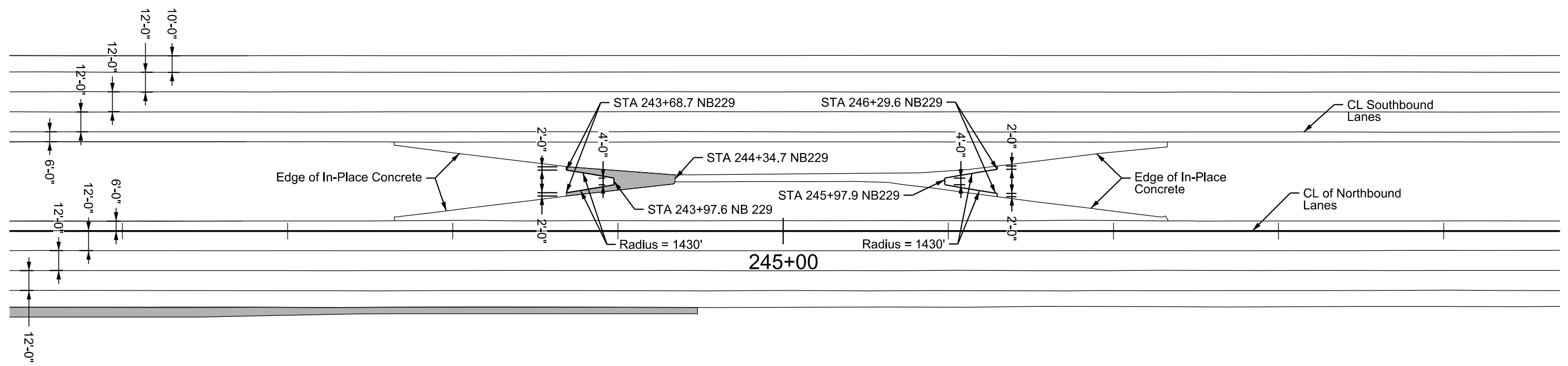

InfrastructureDesignGroup

Plotted From -

File - ...107CVs_SectionF_Crossover-Extensions.dgn

