

SECTION M: PAVEMENT MARKING PLANS

INDEX OF SHEETS:

- M1 General Layout with Index
- M2 - M3 Estimate of Quantities with General Notes & Tables
- M4 - M6 Pavement Marking Layouts
- M7 - M8 Typical Pavement Marking Layouts
- M9 Standard Plates



SECTION M ESTIMATE OF QUANTITIES

BID ITEM NUMBER	ITEM	QUANTITY	UNIT
633E0210	Preformed Thermoplastic Pavement Marking, 4"	5,320	Ft
633E0215	Preformed Thermoplastic Pavement Marking, 8"	1,580	Ft
633E0225	Preformed Thermoplastic Pavement Marking, 24"	260	Ft
633E0230	Preformed Thermoplastic Pavement Marking, Area	40	SqFt
633E0235	Preformed Thermoplastic Pavement Marking, Arrow	9	Each
633E0240	Preformed Thermoplastic Pavement Marking, Combination Arrow	1	Each
633E5000	Grooving for Cold Applied Plastic Pavement Marking, 4"	2,500	Ft
633E5005	Grooving for Cold Applied Plastic Pavement Marking, 8"	1,580	Ft
633E5015	Grooving for Cold Applied Plastic Pavement Marking, 24"	260	Ft
633E5020	Grooving for Cold Applied Plastic Pavement Marking, Area	40	SqFt
633E5025	Grooving for Cold Applied Plastic Pavement Marking, Arrow	8	Each
633E5030	Grooving for Cold Applied Plastic Pavement Marking, Combination Arrow	1	Each
633E5050	Surface Preparation for Pavement Marking	2,820	Ft
633E5052	Surface Preparation for Pavement Marking	1	Each
634E0560	Remove Pavement Marking, 4" or Equivalent	50	Ft
634E0575	Remove Pavement Marking, Area	30.0	SqFt

- Preformed Thermoplastic Pavement Marking, 4": 4060' of white, 1260' of yellow
- Preformed Thermoplastic Pavement Marking, 8": 1580' of white
- Preformed Thermoplastic Pavement Marking, 24": 240' of white, 20' of yellow
- Preformed Thermoplastic Pavement Marking, Area: 40 sqft of white

GROOVING FOR PREFORMED THERMOPLASTIC PAVEMENT MARKING

The Contractor will establish a positive means for the removal of the grinding and/or grooving residue. Residue from dry grooving will be vacuumed. Solid residue will be removed from the pavement surfaces before being blown by traffic action or wind. The Contractor will conduct this work to control and minimize airborne dust and similar debris that may become a hazard to motor vehicle operation or nuisance to property owners. Residue from wet grooving will not be permitted to flow across lanes being used by public traffic or into gutter or drainage facilities. Residue, whether in solid or slurry form, will be disposed of in a manner that will prevent it from reaching any waterway in a concentrated state. The cleaning of the residue for grooving will be to the satisfaction of the Engineer and may require more than one pass to adequately remove material. All costs for removal of grinding and/or grooving residue will be included in the contract unit price per foot, square foot and each for "Grooving for Cold Applied Plastic Pavement Marking" contract items.

Unless otherwise specified in the plans, the Contractor will groove the surface for Preformed Thermoplastic Pavement Marking as specified in these plans and as per the manufacturer's instructions.

The grooving will be completed within the following tolerances:

Description	Specification	Tolerance
Depth of Groove	Marking Thickness ¹ + 15 mils	+ 5 mils
Width of Groove	5 to 6 inches	
Length of Skip Lines ²	10 foot 6 inches	± 3 inch
Tapers at ends of lines	6 to 9 inches	
Between Double Lines	4 inches	± 1/2 inch

¹ Marking thickness will include the thickness of marking material and reflective media.

² Additional length may be required as specified in the plans.

The equipment will be capable of the following:

- Grooving the total width of the groove in one pass or uniform depths with multiple passes.
- Grooving without causing damage to the pavement joints or joint sealant material.
- Provide uniform alignment and depth.
- Moving continuously to permit a mobile traffic work operation.

If damage occurs, including, but not limited to, joints, joint sealant material, and backer rod, the grooving operation will be stopped and modifications will be made to the grooving operation to prevent further damage. The Contractor will be required to use specially prepared circular diamond blade cutting heads to prevent damage at the joints. Damage caused will be repaired or replaced by the Contractor, as directed by the Engineer. No additional payment will be made for the repair work or any reapplication of the pavement marking in the area of the repair.

Grooving on or near bridge decks will start and stop a sufficient distance from the expansion joints so no damage occurs in these areas.

SURFACE PREPARATION FOR PAVEMENT MARKING

The Contractor will prepare the pavement surface prior to applying the preformed thermoplastic pavement marking in accordance with the following:

In areas where the existing groove meets the required depth and existing markings are still in place, the Contractor will clean the existing groove without adding additional depth beyond the required depth for the new pavement marking, including reflective media as noted below.

Description	Specification	Tolerance
Depth of Groove	Marking Thickness ¹ + 15 mils	+ 5 mils

¹ Marking thickness will include the thickness of marking material and reflective media.

The cleaning will result in the existing pavement marking being adequately scuffed, abraded, and removed by light grinding or abrasive blasting or both to allow proper adhesion of the new durable pavement marking as per the manufacturer's recommendations to comply with product warranties.

Existing grooves not meeting the required depth will be re-grooved to the required depth for the new pavement marking, including reflective media. Equipment for grooving will be capable of the following:

- Grooving the total width of the groove in one pass or uniform depths with multiple passes.
- Grooving without causing damage to the pavement joints or joint sealant material.
- Provide uniform alignment and depth.
- Moving continuously to permit a mobile traffic work operation.

All costs associated with cleaning of the existing groove, including re-grooving, if needed, will be included in the contract unit price per foot, square foot and each for "Surface Preparation for Pavement Marking". Surface preparation will be measured as 4" equivalent.

REMOVE PAVEMENT MARKING, 4" OR EQUIVALENT

Markings that fall outside of the new groove will be obliterated using additional methods approved by the Engineer. Removal of the existing markings will be accomplished without causing damage to the pavement, pavement joints, or joint sealant. The Contractor will repair any damage to the pavement, pavement joints, or joint sealant for no additional payment and at no cost to the State. All costs for materials, labor, and equipment necessary to remove the existing markings will be incidental to the contract unit price per foot for "Remove Pavement Marking, 4" or Equivalent".

PREFORMED THERMOPLASTIC PAVEMENT MARKING

The application of preformed thermoplastic pavement marking will begin no sooner than 7 calendar days following completion of the fog or flush seal. Application of preformed thermoplastic pavement marking will be completed within 14 calendar days following completion of the final surfacing.

General

- Made of prefabricated retroreflective, resilient thermoplastic material;
- Contains glass beads uniformly distributed through the entire cross-sectional area;
- Capable of being affixed to bituminous or concrete pavement by heating;
- Resistant to deterioration due to exposure to sunlight, water, salt, and adverse weather conditions;
- Under traffic wear, shows no appreciable fading in accordance with the color requirements, lifting, or shrinkage throughout the life of the marking;
- Capable of conforming to pavement contours, breaks, and faults through the action of traffic at normal pavement temperatures;
- Possesses resealing characteristics, such that it is capable of fusing with itself and previous thermoplastic markings when heated; and
- Protected during shipment and in storage.

Apply the preformed thermoplastic pavement marking as recommended by the manufacturer to provide a neat, durable marking that will not flow, distort, or crack due to temperature if the pavement surface remains stable. Use equipment and application methods specified by the manufacturer. Primer as required by the manufacturer will be provided with the material.

Application of the markings will include the use of any manufacturer recommended sealers. Sealers may be required on concrete pavements, inside grooves, or on older asphalt pavements. Prior to placing any markings on new concrete, the Contractor will remove any curing compounds. Removal will be by sandblasting or other standard industry methods.

Any required primers or sealers will be included in the contract unit price for the various preformed thermoplastic pavement marking items.

Provide precut messages and symbols meeting the requirements of the MUTCD and the Standard Signs Manual in custom kits. Use separate pieces or segments to form individual letters or symbols only to the extent supplied by the manufacturer. Provide shapes, sizes, and colors as required by the contract.

Color

- Will meet the color specification limits and luminance factors for Cold Applied Plastic Pavement Marking and Legends (Section 983.2 D of the Specifications, Tables 1 and 2).

Glass Beads

- Ensure the preformed thermoplastic pavement marking contains a minimum 30% intermixed glass beads by weight and a minimum 80% true spheres.
- Ensure preformed thermoplastic pavement markings contain only clear beads.

Skid Resistance

- Ensure the surface of the preformed thermoplastic pavement marking provides a skid resistance value of at least 45 British Pendulum Number (BPN) when tested in accordance with ASTM E303.

Retroreflectivity

- Provide preformed thermoplastic pavement marking meeting the minimum initial pavement marking retroreflectivity values using 30 m geometry and meeting the testing procedures of ASTM E1710:

Minimum Initial Pavement Marking Retroreflectivity		
	White	Yellow
Thermoplastic	400 mcd/sq. ft./ft.	250 mcd/sq. ft./ft.
Thermoplastic, enhanced skid resistance (ESR)	250 d/sq. ft./ft.	150 d/sq. ft./ft.

Thickness

- A longitudinal marking is a minimum 90 mils thick at the edges, and a maximum 125 mils thick at the center of the stripe.
- Transverse markings and symbols are a minimum 125 mils thick at the edges, and a maximum 160 mils thick at the center.

Sample

- Prior to application, the Contractor will provide a sample of the preformed thermoplastic pavement marking to be used on the project to the Region Traffic Engineer for inspection and approval.
- Do not begin application of the preformed thermoplastic pavement marking prior to obtaining the Region Traffic Engineer's approval of the preformed thermoplastic pavement marking material. The Region Traffic Engineer's approval of the preformed thermoplastic pavement marking does not void other preformed thermoplastic pavement marking requirements specified.

PAVEMENT MARKING LAYOUT

KEY	ITEM	EST QUANT	UNIT
4 WT	Preformed Thermoplastic Pavement Marking, 4" White	4,060	FT
4 YT	Preformed Thermoplastic Pavement Marking, 4" Yellow	1,260	FT
8 WT	Preformed Thermoplastic Pavement Marking, 8" White	1,580	FT
24 WT	Preformed Thermoplastic Pavement Marking, 24" White	240	FT
24 YT	Preformed Thermoplastic Pavement Marking, 24" Yellow	20	FT
SW A	Preformed Thermoplastic Pavement Marking, Area	40	SQFT
	Preformed Thermoplastic PM, Arrow (Lt - 3, Rt - 4, Lt/Th -1, U-turn - 2)	10	EACH

KEY	ITEM	EST QUANT	UNIT
	Grooving for C.A.P. Pavement Marking, 4"	2,500	FT
	Grooving for C.A.P. Pavement Marking, 8"	1,580	FT
	Grooving for C.A.P. Pavement Marking, 24"	260	FT
	Grooving for C.A.P. Pavement Marking, Area	40	SQFT
	Grooving for C.A.P. Pavement Marking, Arrow (Lt - 2, Rt - 4, Lt/Th - 1, U-turn - 2)	9	EACH
	Surface Preparation for Pavement Marking, 4"	2,820	FT
	Surface Preparation for Pavement Marking, Arrow	1	EACH

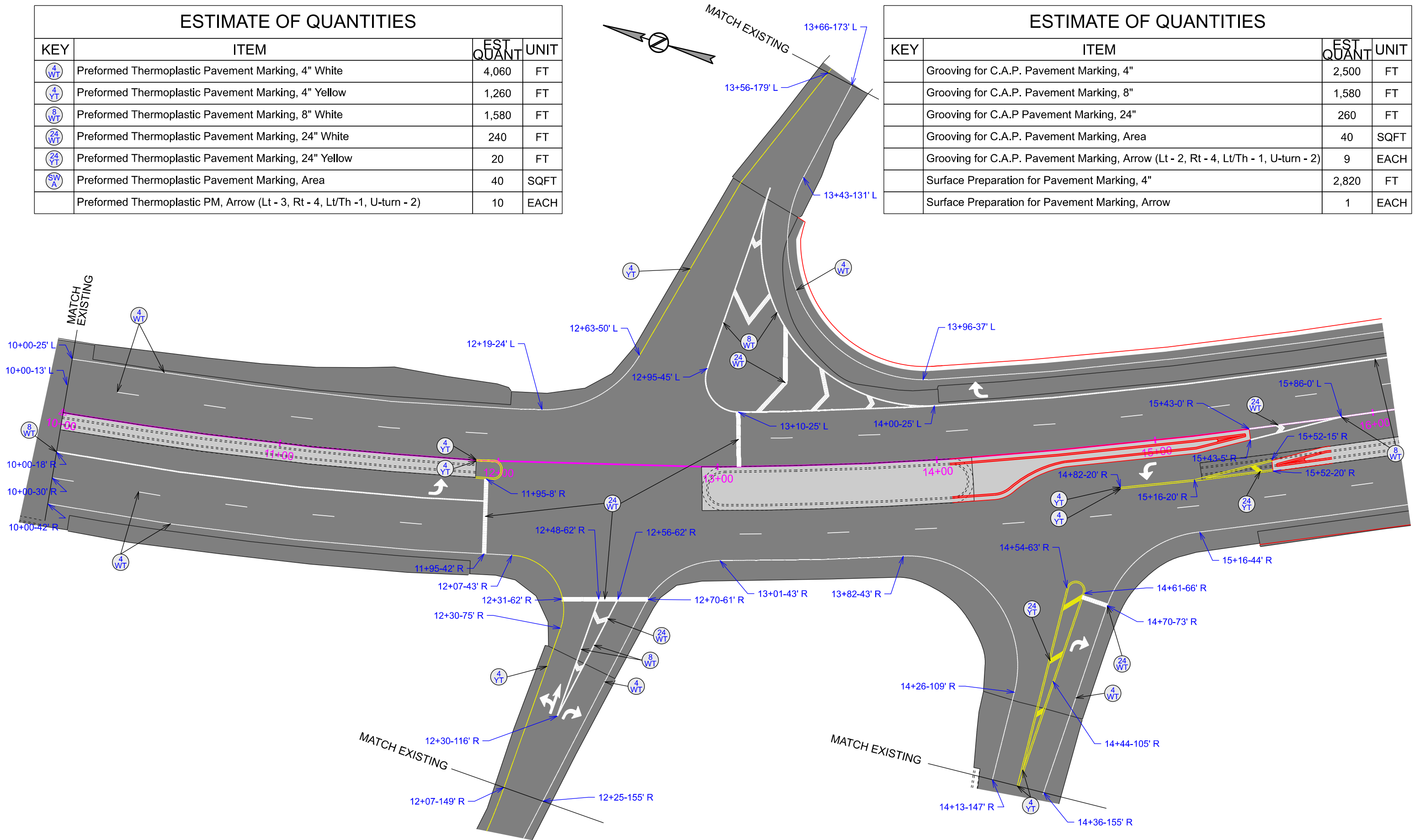

Plotting Date: 3/4/2026

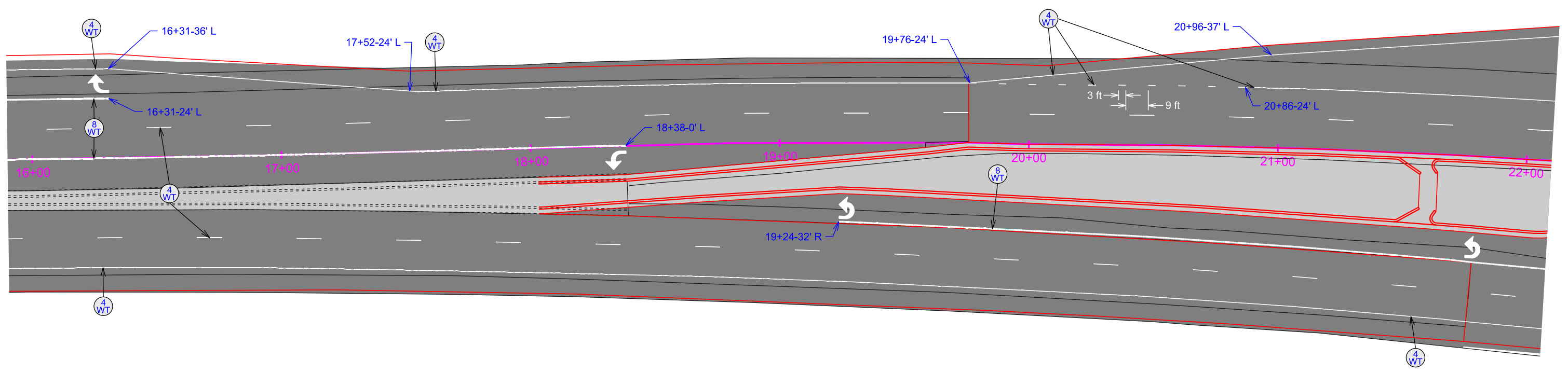
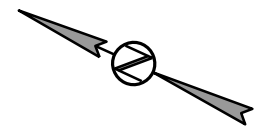

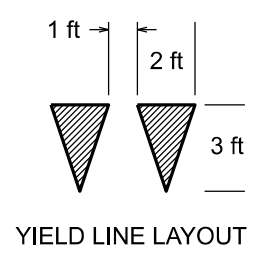
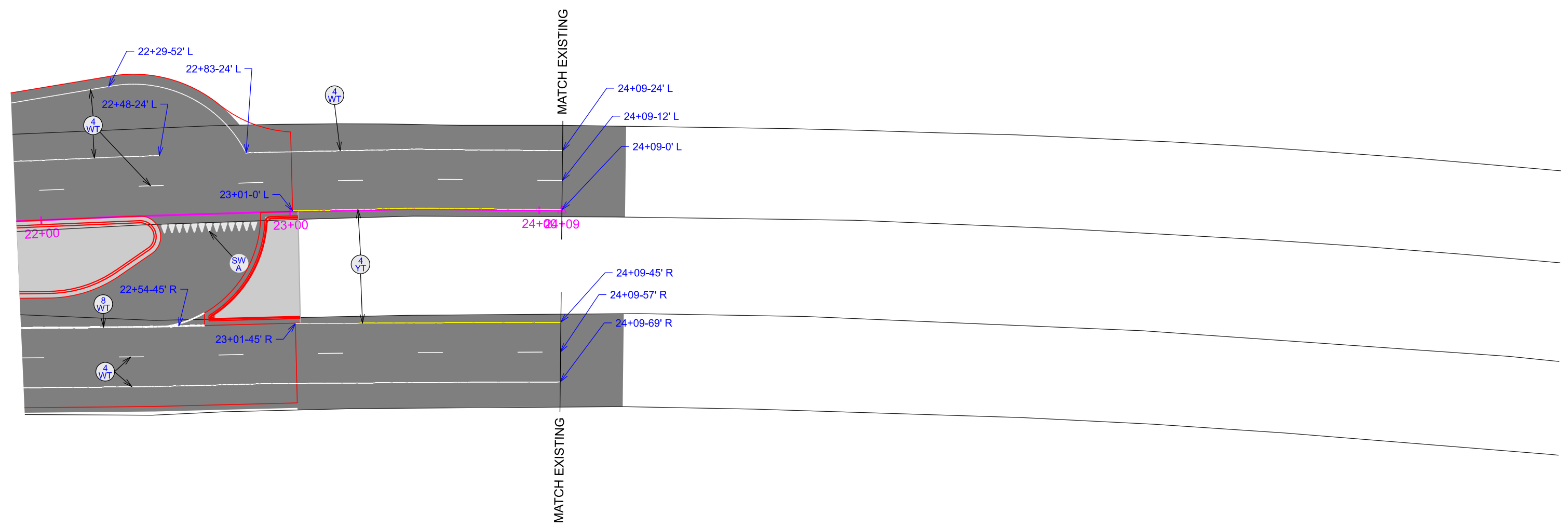
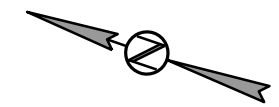

TYPICAL PAVEMENT MARKING LAYOUT



(A) NO PASSING ZONE
(B) End of Zone Marker

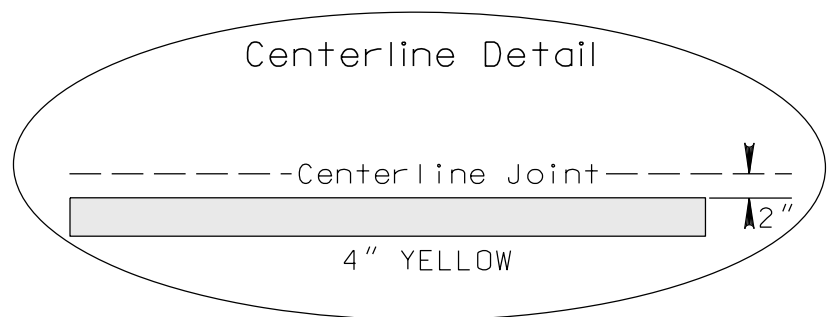
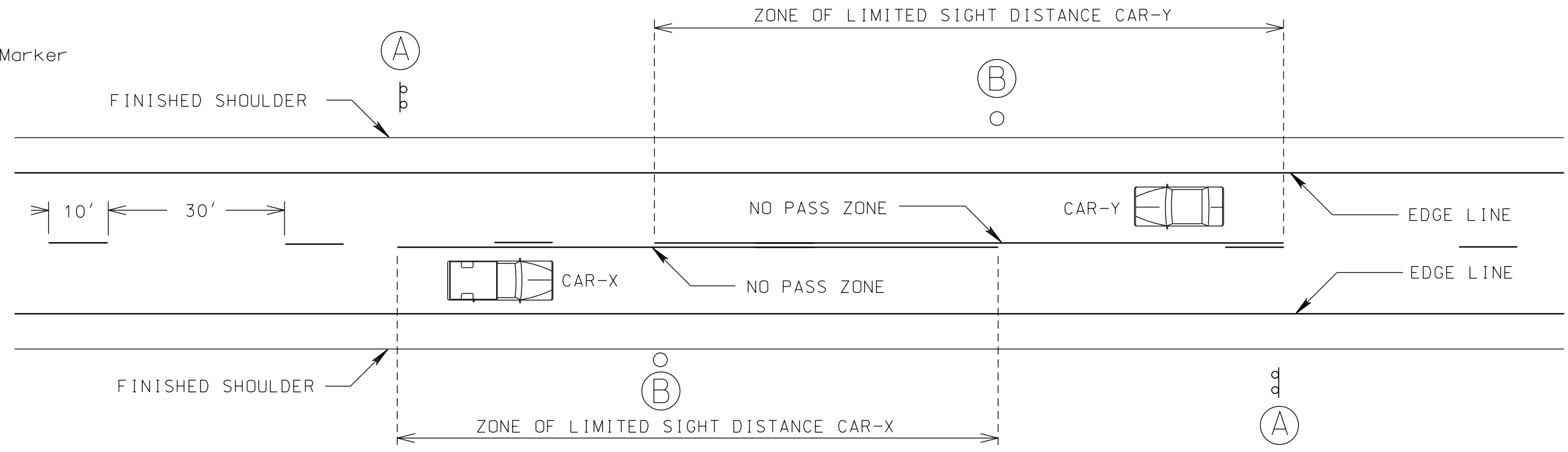

NOTE: A TWO "GUN" SYSTEM WILL BE USED TO OBTAIN THIS PATTERN.
 WHEN A SINGLE SKIP LINE EXISTS, THE SKIP WILL BE PLACED TO THE SOUTH OR EAST OF THE CENTERLINE JOINT.

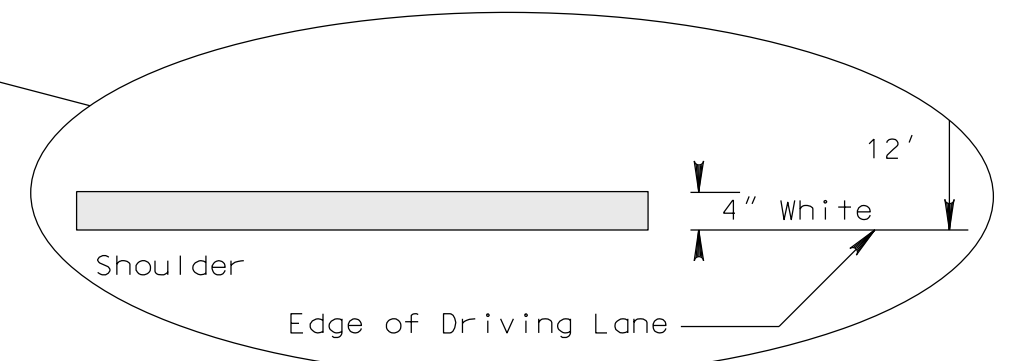
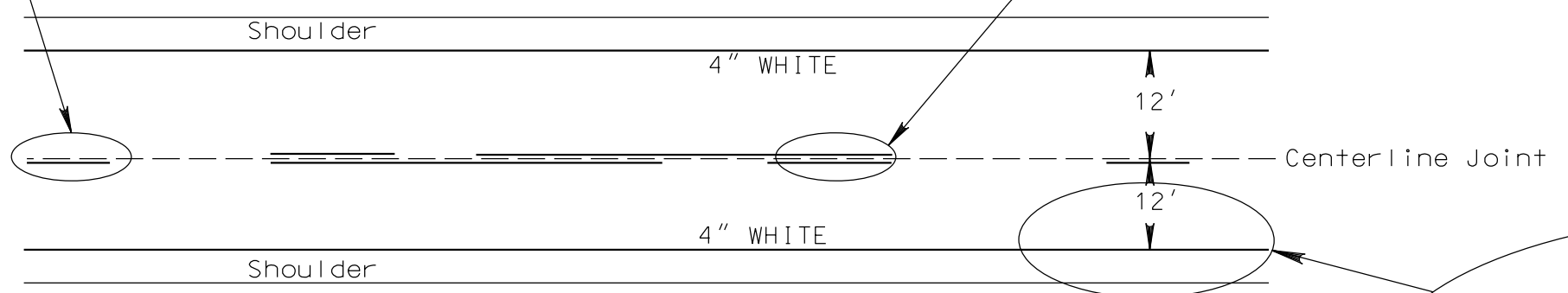
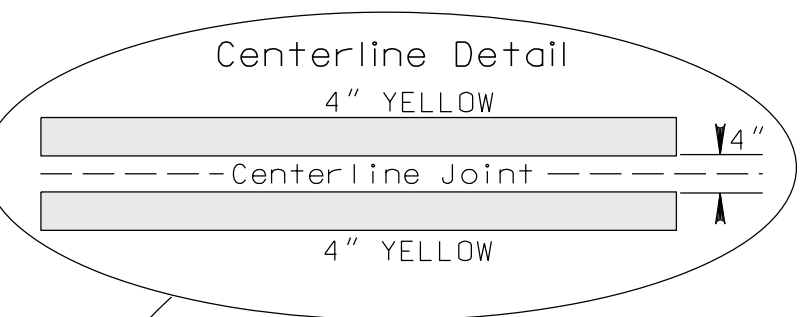

TYPICAL PAVEMENT MARKING LAYOUT

4 LANE DIVIDED HIGHWAY (4" Marking)

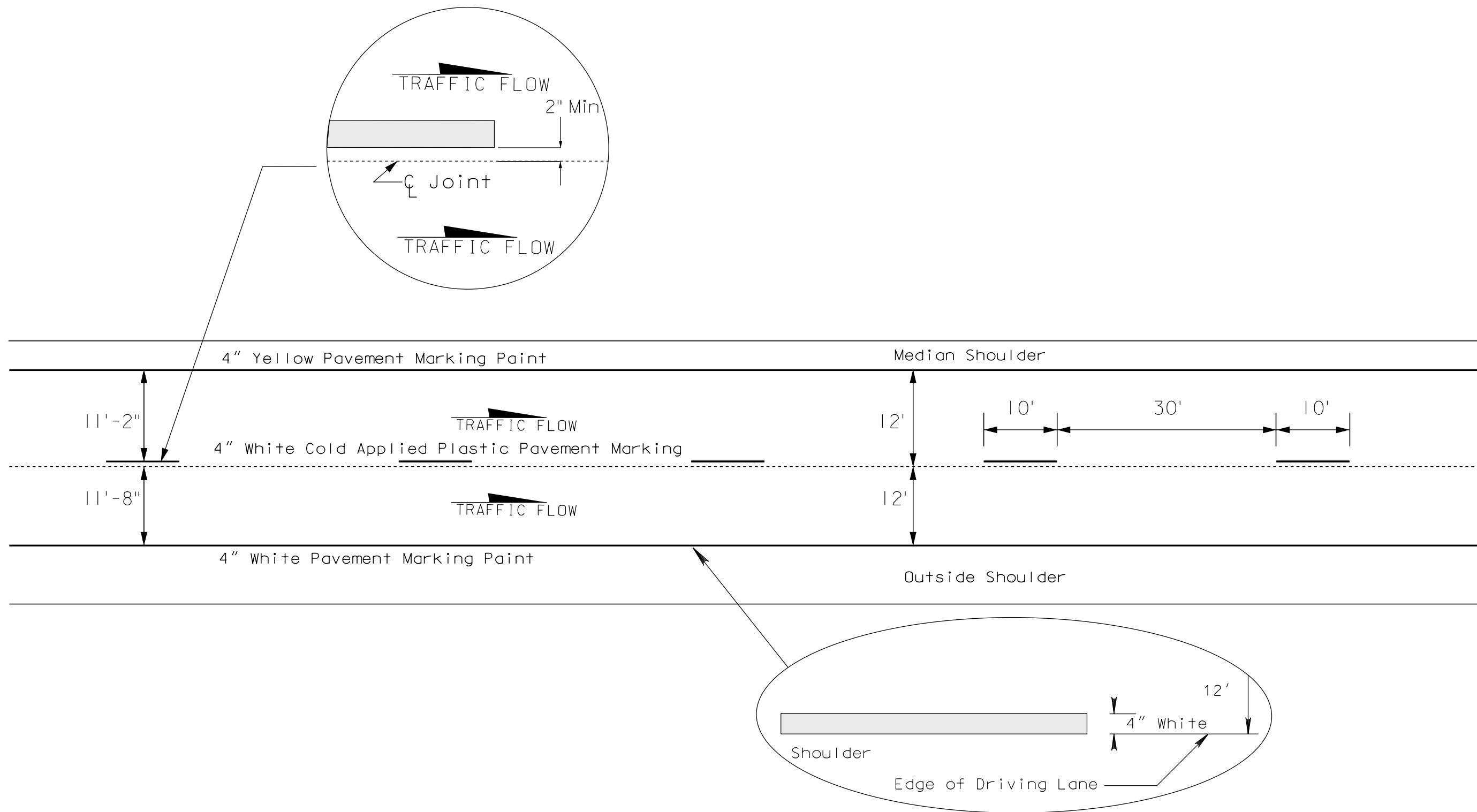

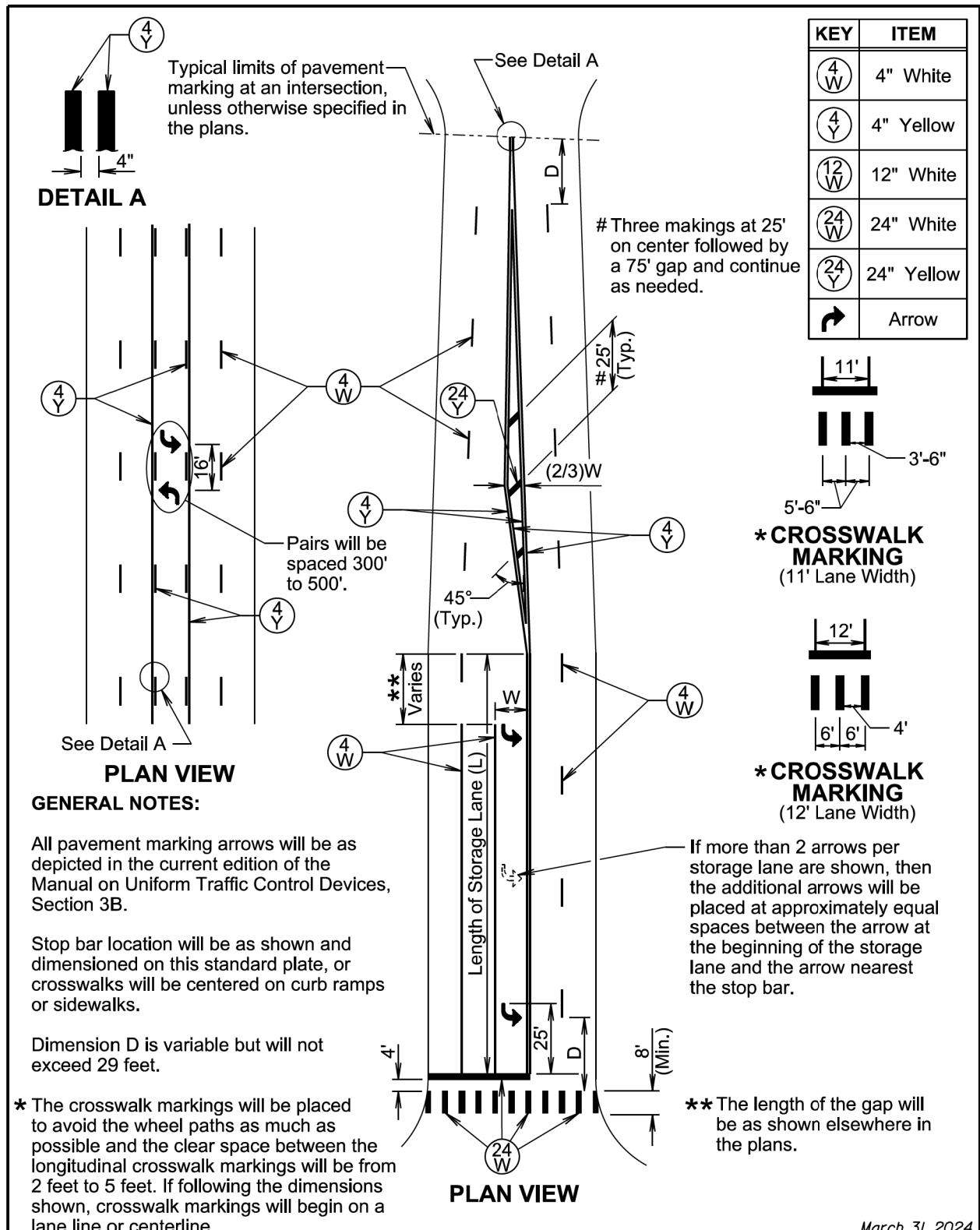

GENERAL NOTES:

All pavement marking arrows will be as depicted in the current edition of the Manual on Uniform Traffic Control Devices, Section 3B.

Stop bar location will be as shown and dimensioned on this standard plate, or crosswalks will be centered on curb ramps or sidewalks.

Dimension D is variable but will not exceed 29 feet.

* The crosswalk markings will be placed to avoid the wheel paths as much as possible and the clear space between the longitudinal crosswalk markings will be from 2 feet to 5 feet. If following the dimensions shown, crosswalk markings will begin on a lane line or centerline.

If more than 2 arrows per storage lane are shown, then the additional arrows will be placed at approximately equal spaces between the arrow at the beginning of the storage lane and the arrow nearest the stop bar.

** The length of the gap will be as shown elsewhere in the plans.

Published Date: 2026	SD DOT	PAVEMENT MARKINGS FOR ADJACENT INTERSECTIONS AND CENTER TURN LANE	March 31, 2024
			PLATE NUMBER 633.01
			Sheet 1 of 1