

# SECTION D: EROSION CONTROL PLANS

## INDEX OF SHEETS

D1	General Layout with Index
D2-D7	Estimate With General Notes & Tables
D8	Legend
D9-D13	Erosion Control Sheets
D14-D15	Standard Plates

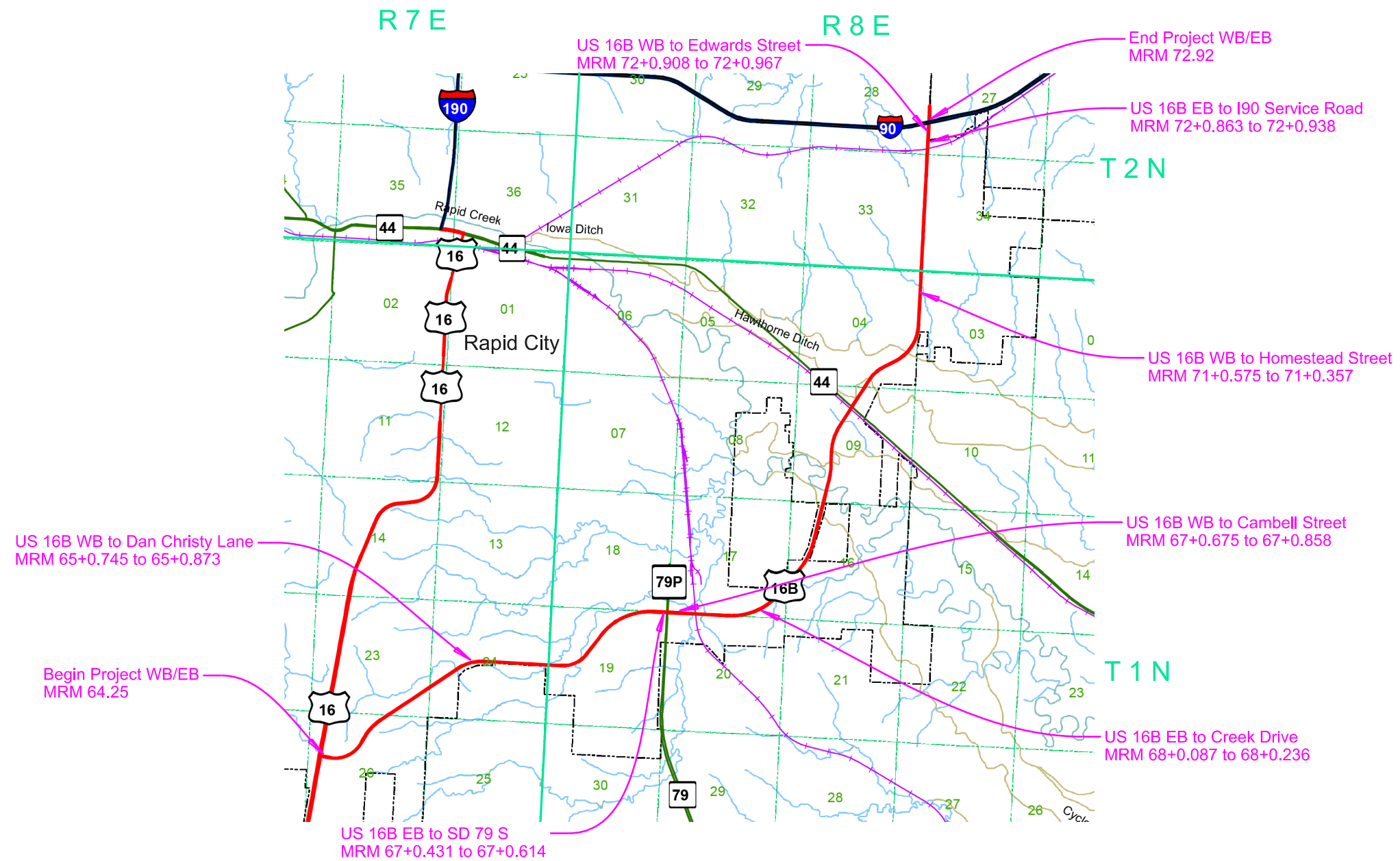

**SECTION D ESTIMATE OF QUANTITIES**

BID ITEM NUMBER	ITEM	QUANTITY	UNIT
110E1690	Remove Sediment	2.7	CuYd
110E1700	Remove Silt Fence	1,105	Ft
230E0010	Placing Topsoil	2,637	CuYd
730E0210	Type F Permanent Seed Mixture	128	Lb
731E0200	Fertilizing	3.68	Ton
732E0250	Fiber Mulching	9,807	Lb
734E0044	Soil Stabilizer	4.9	Acre
734E0132	Type 2 Turf Reinforcement Mat	142.0	SqYd
734E0154	12" Diameter Erosion Control Wattle	1,185	Ft
734E0165	Remove and Reset Erosion Control Wattle	296	Ft
734E0604	High Flow Silt Fence	1,105	Ft
734E0610	Mucking Silt Fence	77	CuYd
734E0620	Repair Silt Fence	276	Ft

**PLACING TOPSOIL**

The thickness will be approximately 4 inches within the right-of-way and 6 inches on temporary easements.

The estimated amount of topsoil to be placed is as follows:

Location	Topsoil (CuYd)
US16B/Dan Christy Lane	318
US16B/SD79S	692
US16B/Cambell Street	842
US16B/Creek Drive	486
US16B/I90 Serivce Road	157
US16B/Edwards Street	142
Total:	2637

**MYCORRHIZAL INOCULUM**

Mycorrhizal inoculum will consist of mycorrhizal fungi spores and mycorrhizal fungi-infected root fragments in a solid carrier. The carrier may include organic materials, calcinated clay, or other materials consistent with application and good plant growth. The supplier will provide certification of the fungal species claimed and the live propagule count. The inoculum will include a minimum 25% the fungal species *Rhizophagus intraradices*. The remaining 75% may include other endomycorrhizal fungal species.

All seed will be inoculated by the seed supplier with a minimum of 100,000 live propagules of mycorrhizal fungi per acre. All costs of inoculating the seed will be incidental to the contract unit price per pound for the corresponding permanent seed mixture.

The Mycorrhizal Inoculum provided will be from the approved product list. The approved product list may be viewed at the following internet site:

<https://apps.sd.gov/HC60ApprovedProducts/main.aspx>

**FERTILIZING**

The Contractor will apply an all-natural slow release fertilizer prior to seeding or placing sod. The all-natural fertilizer will have a minimum guaranteed analysis of 4-4-4 and be USDA Certified BioBased. It should provide a minimum of 4% (N) nitrogen with a minimum water insoluble nitrogen (WIN) fraction of 2.07%, a minimum of 4% (P2O5) available phosphate, a minimum of 4% (K2O) soluble potash, and a maximum carbon to nitrogen ratio (C:N ratio) of 5:1. The all-natural fertilizer will be free of weed-seed and pathogens accomplished through thermophilic composting, and not mechanical or chemical sterilization, to assure presence of beneficial soil microbiology. The fertilizer will have a near neutral pH, a low salt index, a low biological oxygen demand, contain organic humic and fulvic acids, and have high aerobic organism counts. The fertilizer will also be stable, free of bad odors, and be unattractive as a food source for animals. It should also be in a granular form that is easily spread.

The fertilizer will be applied at a rate of 1,500 pounds per acre in accordance with the manufacturer's recommended method of application.

The Fertilizer provided will be from the approved product list. The approved product list may be viewed at the following internet site:

<https://apps.sd.gov/HC60ApprovedProducts/main.aspx>

**PERMANENT SEEDING**

The areas to be seeded consist of all newly graded areas within the project limits except for the top of roadways, temporary easements under cultivation,

Type F Permanent Seed Mixture will consist of the following:

Grass Species	Variety	Pure Live Seed (PLS) (Pounds/Acre)
Western Wheatgrass	Arriba, Flintlock, Rodan, Rosana, Walsh	7
Green Needlegrass	Lodorm, AC Mallard Ecovar	4
Sideoats Grama	Butte, Pierre	3
Blue Grama	Bad River	2
Oats or Spring Wheat:		10
April through May;		
Winter Wheat: August through November		
Total:		26

**FIBER MULCHING**

Fiber mulch will be applied in a separate operation following permanent seeding.

The Contractor will allow the fiber mulch to cure a minimum of 18 hours prior to watering or any storm event to ensure proper cohesion between the soil and fiber particles.

The fiber mulch provided will be from the approved product list. The approved product list for fiber mulch may be viewed at the following internet site:

<https://apps.sd.gov/HC60ApprovedProducts/main.aspx>

**TABLE OF SEEDING, MULCHING, AND FERTILIZING**

Location	Area (Acres)	Type F Seed Mixture (Lb)	Fiber Mulching (Lb)	Fertilizing (Ton)
US16B/Dan Christy Lane	0.6	15	1181	0.44
US16B/SD79S	1.3	33	2574	0.97
US16B/Cambell Street	1.6	41	3131	1.17
US16B/Creek Drive	0.9	24	1808	0.68
US16B/I90 Serivce Road	0.3	8	584	0.22
US16B/Edwards Street	0.3	7	529	0.20
Totals:	4.9	128	9807	3.68

**SOIL STABILIZER**

An estimated quantity of 4.9 acres of soil stabilizer has been included in the Estimate of Quantities. The soil stabilizer will be applied on permanently seeded areas and areas deemed necessary by the Engineer.

The Contractor will apply soil stabilizer in accordance with the manufacturer's application instructions and at the rate specified in the list of approved soil stabilizers.

Wood fiber mulch that contains a green dye will be mixed with the soil stabilizer to be used as a tracer when the soil stabilizer is applied hydraulically. Wood fiber mulch will be added at a rate of 300 pounds per acre to all of the approved soil stabilizers listed in the table except for the Pam-12 Plus product. The wood fiber mulch will be a 100% wood fiber product and does not need to contain a tackifier.

All costs for furnishing and applying the soil stabilizer including wood fiber mulch, hauling, materials, equipment, labor, and incidentals necessary will be paid for at the contract unit price per Acre for "Soil Stabilizer".

The Soil Stabilizer provided will be from the approved product list. The approved product list may be viewed at the following internet site:

<https://apps.sd.gov/HC60ApprovedProducts/main.aspx>

**EROSION CONTROL WATTLE**

Erosion control wattles for restraining the flow of runoff and sediment will be installed at locations noted in the table and at locations determined by the Engineer during construction. Refer to Standard Plate 734.06 for details.

The Contractor will provide certification that the erosion control wattles do not contain noxious weed seeds.

Erosion control wattles will remain on the project to decompose.

An additional quantity of 12" Diameter Erosion Control Wattles has been added to the Estimate of Quantities for temporary erosion and sediment control in highway ditch channels and as an alternative to low flow or high flow silt fence at wetland areas adjacent to the highway.

The erosion control wattle provided will be from the approved product list. The approved product list for erosion control wattle may be viewed at the following internet site:

<https://apps.sd.gov/HC60ApprovedProducts/main.aspx>

**TABLE OF EROSION CONTROL WATTLE**

Location	Description	Diameter (Inch)	Quantity (Ft)
US16B/Dan Christy Lane	Highway Ditch (75 Ft spacing)	12	210
US16B/Creek Drive	Highway Ditch	12	50
US16B/I90 Service Road	Perimeter Control	12	325
	Additional Quantity:	12	600
		<b>Total:</b>	<b>1185</b>

**HIGH FLOW SILT FENCE**

The high flow silt fence fabric provided will be from the approved product list. The approved product list for high flow silt fence may be viewed at the following internet site:

<https://apps.sd.gov/HC60ApprovedProducts/main.aspx>

High flow silt fence will be placed at the locations noted in the table and at locations that will minimize siltation of adjacent streams, lakes, dams, or drainage areas as determined by the Engineer during construction. Refer to Standard Plate 734.05 for details.

**TABLE OF HIGH FLOW SILT FENCE**

Location	Station	Description	Quantity (Ft)
US16B/Dan Christy Lane	7+15	Perimeter Control Across Ditch	45
US16B/SD79S	5+52	Pipe Inlet	40
US16B/Cambell Street	2+30 to 8+50	Perimeter Control	630
US16B/Creek Drive	3+75	Perimeter Control Across Ditch	55
US16B/Edwards Street	2+09	Pipe Inlet	35
		Additional Quantity:	300
		<b>Total:</b>	<b>1105</b>

**TURF REINFORCEMENT MAT**

Turf Reinforcement Mat will be installed at locations shown in the table at the widths specified, and at locations determined by the Engineer during construction. The Contractor will use a turf reinforcement mat from the approved products list. The approved product list for turf reinforcement mat may be viewed at the following internet site:

<https://apps.sd.gov/HC60ApprovedProducts/main.aspx>

Turf Reinforcement Mat will be installed in accordance with the manufacturer's installation instructions.

**TABLE OF TURF REINFORCEMENT MAT**

Location	Station	Description	Type	Quantity (SqYd)
US16B/SD79S	5+12 to 5+92	Ditch Bottom	2	142
			<b>Total Type 2 Turf Reinforcement Mat:</b>	<b>142</b>

**STORMWATER POLLUTION PREVENTION PLAN CHECKLIST**

*(The numbers left of the title headings are reference numbers to the GENERAL PERMIT FOR STORM WATER DISCHARGES ASSOCIATED WITH CONSTRUCTION ACTIVITIES (Stormwater Permit))*

**5.3 (2): STAFF TRAINING/SWPPP IMPLEMENTATION**

To promote stormwater management awareness specific for this project, the Contractor's Erosion Control Supervisor should provide correspondence of how the SWPPP will be implemented. The Contractor's Erosion Control Supervisor is responsible for providing this information at the preconstruction meeting, and subsequently completing an attendance log, which should identify site-specific implementation of the SWPPP and the names of the personnel who attended the preconstruction meeting. Documentation of the preconstruction meeting will be filed with the SWPPP documents.

**5.3 (3): DESCRIPTION OF CONSTRUCTION ACTIVITIES**

- **5.3 (3a): Project Limits** (See Title Sheet)
- **5.3 (3a): Project Description** (See Title Sheet)
- **5.3 (4): Site Map(s)** (See Title Sheet and Plans)
- **Major Soil Disturbing Activities** (check all that apply)
  - Clearing and grubbing
  - Excavation/borrow
  - Grading and shaping
  - Filling
  - Other (describe):
- **5.3 (3b): Total Project Area** 8.0 ac
- **5.3 (3b): Total Area to be Disturbed** 6.8 ac
- **5.3 (3c): Maximum Area Disturbed at One Time** 6.8 ac
- **5.3 (3d): Existing Vegetative Cover (%)**
- **5.3 (3d): Description of Vegetative Cover**
- **5.3 (3e): Soil Properties:** A-4, A-6, A-7, A-7-6
- **5.3 (3f): Name of Receiving Water Body/Bodies** Tributaries of Rapid and Boxelder Creeks
- **5.3 (3g): Location of Construction Support Activity Areas**

**5.3 (3h): ORDER OF CONSTRUCTION ACTIVITIES**

The Contractor will enter the Estimated Start Date.

Description	Estimated Start Date
Install stabilized construction entrance(s).	
Install perimeter protection where runoff may exit site.	
Install perimeter protection around stockpiles.	
Install channel and ditch bottom protection.	
Clearing and grubbing.	
Remove and stockpile topsoil.	
Stabilize disturbed areas.	
Install utilities, storm sewers, curb and gutter.	
Install inlet and culvert protection after completing storm drainage and other utility installations.	
Final grading.	
Final paving.	
Removal of protection devices.	
Reseed areas disturbed by removal activities.	

**5.3 (5): DESCRIPTION AND MAINTENANCE OF CONTROL MEASURES**

All controls will be maintained in good working order. Necessary repairs will be initiated within 24 hours of the site inspection report. Include the technical reasoning for selecting each control. (check all that apply)

**Perimeter Controls (See Detail Plan Sheets)**

Description	Estimated Start Date
<input type="checkbox"/> Natural Buffers (within 50 ft of Waters of State)	
<input checked="" type="checkbox"/> Silt Fence	
<input checked="" type="checkbox"/> Erosion Control Wattles	
<input type="checkbox"/> Temporary Berm / Windrow	
<input type="checkbox"/> Floating Silt Curtain	
<input type="checkbox"/> Stabilized Construction Entrances	
<input type="checkbox"/> Entrance/Exit Equipment Tire Wash	
<input type="checkbox"/> Other:	

**Structural Erosion and Sediment Controls**

Description	Estimated Start Date
<input checked="" type="checkbox"/> Silt Fence	
<input type="checkbox"/> Temporary Berm/Windrow	
<input checked="" type="checkbox"/> Erosion Control Wattles	
<input type="checkbox"/> Temporary Sediment Barriers	
<input type="checkbox"/> Erosion Bales	
<input type="checkbox"/> Temporary Slope Drain	
<input checked="" type="checkbox"/> Turf Reinforcement Mat	
<input checked="" type="checkbox"/> Riprap	
<input type="checkbox"/> Gabions	
<input type="checkbox"/> Rock Check Dams	
<input type="checkbox"/> Sediment Traps/Basins	
<input type="checkbox"/> Culvert Inlet Protection	
<input type="checkbox"/> Transition Mats	
<input type="checkbox"/> Median/Area Drain Inlet Protection	
<input type="checkbox"/> Curb Inlet Protection	
<input type="checkbox"/> Interceptor Ditch	
<input type="checkbox"/> Concrete Washout Facility	
<input type="checkbox"/> Work Platform	
<input type="checkbox"/> Temporary Water Barrier	
<input type="checkbox"/> Temporary Water Crossing	
<input type="checkbox"/> Permanent Stormwater Ponds	
<input type="checkbox"/> Permanent Open Vegetated Swales	
<input type="checkbox"/> Natural Depressions to allow for Infiltration	
<input type="checkbox"/> Sequential Systems that combine several practices	
<input type="checkbox"/> Other:	

**Dust Controls**

Description	Estimated Start Date
<input type="checkbox"/> Tarps & Wind impervious fabrics	
<input type="checkbox"/> Watering	
<input type="checkbox"/> Stockpile location/orientation	
<input type="checkbox"/> Dust Control Chlorides	
<input type="checkbox"/> Other	

**Dewatering BMPs**

Description	Estimated Start Date
<input type="checkbox"/> Sediment Basins	
<input type="checkbox"/> Dewatering bags	
<input type="checkbox"/> Weir tanks	
<input type="checkbox"/> Temporary Diversion Channel	
<input type="checkbox"/> Other:	

**Stabilization Practices (See Detail Plan Sheets)**

(Stabilization measures will begin the following work day whenever earth disturbing activity on any portion of the site has temporarily or permanently ceased. Temporary stabilization will be completed as soon as practicable but no later than 14 days after initiating soil stabilization activities (3.18))

Description	Estimated Start Date
<input type="checkbox"/> Vegetation Buffer Strips	
<input type="checkbox"/> Temporary Seeding (Cover Crop Seeding)	
<input checked="" type="checkbox"/> Permanent Seeding	
<input type="checkbox"/> Sodding	
<input type="checkbox"/> Planting (Woody Vegetation for Soil Stabilization)	
<input checked="" type="checkbox"/> Mulching (Grass Hay or Straw)	
<input type="checkbox"/> Fiber Mulching (Wood Fiber Mulch)	
<input type="checkbox"/> Soil Stabilizer	
<input type="checkbox"/> Bonded Fiber Matrix	
<input type="checkbox"/> Fiber Reinforced Matrix	
<input type="checkbox"/> Erosion Control Blankets	
<input type="checkbox"/> Surface Roughening (e.g. tracking)	
<input type="checkbox"/> Other:	

**Wetland Avoidance**

Will construction and/or erosion and sediment controls impinge on regulated wetlands? Yes  No  If yes, the structural and erosion and sediment controls have been included in the total project wetland impacts and have been included in the 404 permit process with the USACE.

### 5.3 (6): PROCEDURES FOR INSPECTIONS

- Inspections will be conducted at least once every 7 days.
- All controls will be maintained in good working order. Necessary repairs will be initiated within 24 hours of the site inspection report.
- Silt fence will be inspected for depth of sediment and for tears to ensure the fabric is securely attached to the posts and that the posts are well anchored. Sediment buildup will be removed from the silt fence when it reaches 1/3 of the height of the silt fence.
- Sediment basins and traps will be checked. Sediment will be removed when depth reaches approximately 50 percent of the structure's capacity, and at the conclusion of the construction.
- Check dams will be inspected for stability. Sediment will be removed when depth reaches 1/2 the height of the dam.
- All seeded areas will be checked for bare spots, washouts, and vigorous growth free of significant weed infestations.
- Inspection and maintenance reports will be prepared on form DOT 298 for each site inspection, this form will also be used to document changes to the SWPPP. A copy of the completed inspection form will be filed with the SWPPP documents.
- The SDDOT Project Engineer and Contractor's Erosion Control Supervisor are responsible for inspections. Maintenance and repair activities are the responsibility of the Contractor. The SDDOT Project Engineer will complete the inspection and maintenance reports and distribute copies per the distribution instructions on DOT 298.

### 5.3 (7): POST CONSTRUCTION STORMWATER MANAGEMENT

Stormwater management will be handled by temporary controls outlined in "DESCRIPTION AND MAINTENANCE OF CONTROL MEASURES" above, and any permanent controls needed to meet permanent stormwater management needs in the post construction period will be shown in the plans and noted as permanent.

### 5.3 (8): POLLUTION PREVENTION PROCEDURES

#### 5.3 (8a): Spill Prevention and Response Procedures

##### ➤ Material Management

- Housekeeping
  - Only needed products will be stored on-site by the Contractor.
  - Except for bulk materials the contractor will store all materials under cover and/or in appropriate containers.
  - Products must be stored in original containers and labeled.
  - Material mixing will be conducted in accordance with the manufacturer's recommendations.
  - When possible, all products will be completely used before properly disposing of the container off-site.
  - The manufacturer's directions for disposal of materials and containers will be followed.
  - The Contractor's site superintendent will inspect materials storage areas regularly to ensure proper use and disposal.
  - Dust generated will be controlled in an environmentally safe manner.
- Hazardous Materials
  - Products will be kept in original containers unless the container is not resealable and provide secondary containment as applicable.
  - Original labels and material safety data sheets will be retained in a safe place to relay important product information.
  - If surplus product must be disposed of, manufacturer's label directions for disposal will be followed.

- Maintenance and repair of all equipment and vehicles involving oil changes, hydraulic system drain down, de-greasing operations, fuel tank drain down and removal, and other activities which may result in the accidental release of contaminants will be conducted on an impervious surface and under cover during wet weather to prevent the release of contaminants onto the ground.
- Wheel wash water will be collected and allowed to settle out suspended solids prior to discharge. Wheel wash water will not be discharged directly into any stormwater system or stormwater treatment system.
- Potential pH-modifying materials such as: bulk cement, cement kiln dust, fly ash, new concrete washings, concrete pumping, residuals from concrete saw cutting (either wet or dry), and mixer washout waters will be collected on site and managed to prevent contamination of stormwater runoff.

##### ➤ Spill Control Practices

In addition to the previous housekeeping and management practices, the following practices will be followed for spill prevention and cleanup if needed.

- For all hazardous materials stored on site, the manufacturer's recommended methods for spill cleanup will be clearly posted. Site personnel will be made aware of the procedures and the locations of the information and cleanup supplies.
- Appropriate cleanup materials and equipment will be maintained by the Contractor in the materials storage area on-site. As appropriate, equipment and materials may include items such as brooms, dust pans, mops, rags, gloves, goggles, kitty litter, sand, sawdust, and plastic and metal trash containers specifically for cleanup purposes.
- All spills will be cleaned immediately after discovery and the materials disposed of properly.
- The spill area will be kept well ventilated and personnel will wear appropriate protective clothing to prevent injury from contact with a hazardous substance.
- After a spill a report will be prepared describing the spill, what caused it, and the cleanup measures taken. The spill prevention plan will be adjusted to include measures to prevent this type of spill from reoccurring, as well as clean up instructions in the event of reoccurrences.
- The Contractor's site superintendent, responsible for day-to-day operations, will be the spill prevention and cleanup coordinator.

##### ➤ Spill Response

The primary objective in responding to a spill is to quickly contain the material(s) and prevent or minimize migration into stormwater runoff and conveyance systems. If the release has impacted on-site stormwater, it is critical to contain the released materials on-site and prevent their release into receiving waters. If a spill of pollutants threatens stormwater or surface water at the site, the spill response procedures outlined below must be implemented in a timely manner to prevent the release of pollutants.

- The Contractor's site superintendent will be notified immediately when a spill or the threat of a spill is observed. The superintendent will assess the situation and determine the appropriate response.
- If spills represent an imminent threat of escaping erosion and sediment controls and entering receiving waters, personnel will be directed to respond immediately to contain the release and notify the superintendent after the situation has been stabilized.

- Spill kits containing appropriate materials and equipment for spill response and cleanup will be maintained by the Contractor at the site.
- If oil sheen is observed on surface water (e.g. settling ponds, detention ponds, swales), action will be taken immediately to remove the material causing the sheen. The Contractor will use appropriate materials to contain and absorb the spill. The source of the oil sheen will also be identified and removed or repaired as necessary to prevent further releases.
- If a spill occurs the superintendent or the superintendent's designee will be responsible for completing the spill reporting form and for reporting the spill to SDDANR.
- Personnel with primary responsibility for spill response and cleanup will receive training by the Contractor's site superintendent or designee. The training must include identifying the location of the spill kits and other spill response equipment and the use of spill response materials.
- Spill response equipment will be inspected and maintained as necessary to replace any materials used in spill response activities.

### 5.3 (8b): WASTE MANAGEMENT PROCEDURES

##### ➤ Waste Disposal

- All liquid waste materials will be collected and stored in approved sealed containers. All trash and construction debris from the site will be deposited in the approved containers. Containers will be serviced as necessary, and the trash will be hauled to an approved disposal site or licensed landfill. All onsite personnel will be instructed in the proper procedures for waste disposal and notices stating proper practices will be posted. The Contractor is responsible for ensuring waste disposal procedures are followed.

##### ➤ Hazardous Waste

- All hazardous waste materials will be disposed of in a manner specified by local or state regulations or by the manufacturer. Site personnel will be instructed in these practices, and the Contractor will be responsible for seeing that these practices are followed.

##### ➤ Sanitary Waste

- Portable sanitary facilities will be provided on all construction sites. Sanitary waste will be collected from the portable units which must be secured to prevent tipping and serviced in a timely manner by a licensed waste management Contractor or as required by any local regulations.

**5.3 (9): CONSTRUCTION SITE POLLUTANTS**

The following materials or substances are expected to be present on the site during the construction period. These materials will be handled as noted under the heading "POLLUTION PREVENTION PROCEDURES" (check all that apply).

- Concrete and Portland Cement
- Detergents
- Paints
- Metals
- Bituminous Materials
- Petroleum Based Products
- Diesel Exhaust Fluid
- Cleaning Solvents
- Wood
- Cure
- Texture
- Chemical Fertilizers
- Other:

**Product Specific Practices**

▪ **Petroleum Products**

All on-site vehicles will be monitored for leaks and receive regular preventive maintenance to reduce the chance of leakage. Petroleum products will be stored in tightly sealed containers which are clearly labeled.

▪ **Fertilizers**

Fertilizers will be applied only in the amounts specified by the SDDOT. Once applied, fertilizers will be worked into the soil to limit the exposure to stormwater. Fertilizers will be stored in an enclosed area. The contents of partially used fertilizer bags will be transferred to sealable containers to avoid spills.

▪ **Paints**

All containers will be tightly sealed and stored when not required for use. The excess will be disposed of according to the manufacturer's instructions and any applicable state and local regulations.

▪ **Concrete Trucks**

Contractors will provide designated truck washout facilities on the site. These areas must be self-contained and not connected to any stormwater outlet of the site. Upon completion of construction, the area at the washout facility will be properly stabilized.

**5.3 (10): NON-STORMWATER DISCHARGES**

The following non-stormwater discharges are anticipated during the course of this project (check all that apply).

- Discharges from water line flushing.
- Pavement wash-water, where no spills or leaks of toxic or hazardous materials have occurred.
- Uncontaminated ground water associated with dewatering activities.

**5.3 (11): INFEASIBILITY DOCUMENTATION**

If it is determined to be infeasible to comply with any of the requirements of the Stormwater Permit, the infeasibility determination must be thoroughly documented in the SWPPP.

**7.0: SPILL NOTIFICATION**

In the event of a spill, the Contractor's site superintendent will make the appropriate notification(s), consistent with the following procedures:

- A release or spill of a regulated substance (includes petroleum and petroleum products) must be reported to SDDANR immediately **if any one of the following** conditions exists:
  - The release or spill threatens or is able to threaten waters of the state (surface water or ground water)
  - The release or spill causes an immediate danger to human health or safety
  - The release or spill exceeds 25 gallons
  - The release or spill causes a sheen on surface water
  - The release or spill of any substance that exceeds the ground water quality standards of ARSD Chapter 74:54:01
  - The release or spill of any substance that exceeds the surface water quality standards of ARSD Chapter 74:51:01
  - The release or spill of any substance that harms or threatens to harm wildlife or aquatic life
  - The release or spill is required to be reported according to Superfund Amendments and Reauthorization Act (SARA) Title III List of Lists, Consolidated List of Chemicals Subject to Reporting Under the Emergency Planning and Community Right to Know Act, US Environmental Protection Agency.
- To report a release or spill, call SDDANR at 605-773-3296 during regular office hours (8 a.m. to 5 p.m. Central Standard Time). To report the release after hours, on weekends or holidays, call South Dakota Emergency Management at 605-773-3231. Reporting the release to SDDANR does not meet any obligation for reporting to other state, local, or federal agencies. Therefore, you must also contact local authorities to determine the local reporting requirements for releases. A written report of the unauthorized release of any regulated substance, including quantity discharged, and the location of the discharge will be sent to SDDANR within 14 days of the discharge.

**5.4: SWPPP CERTIFICATIONS**

➤ **Certification of Compliance with Federal, State, and Local Regulations**

The Storm Water Pollution Prevention Plan (SWPPP) for this project reflects the requirements of all local municipal jurisdictions for storm water management and sediment and erosion control as established by ordinance, as well as other state and federal requirements for sediment and erosion control plans, permits, notices or documentation as appropriate.

➤ **South Dakota Department of Transportation**

I certify under penalty of law that this document and all attachments were prepared under my direction or supervision in accordance with a system designed to assure that qualified personnel properly gather and evaluate the information submitted. Based on my inquiry of the person or persons who manage the system, or those persons directly responsible for gathering the information, the information submitted is, to the best of my knowledge and belief, true, accurate, and complete. I am aware that there are significant penalties for submitting false information, including the possibility of fine and imprisonment for knowing violations.



\_\_\_\_\_  
Authorized Signature (See the General Permit, Section 7.4 (1))

➤ **Prime Contractor**

This section is to be executed by the General Contractor after the award of the contract. This section may be executed any time there is a change in the Prime Contractor of the project.

I certify under penalty of law that this document and all attachments will be revised or maintained under my direction or supervision in accordance with a system designed to assure that qualified personnel properly gather and evaluate the information submitted. Based on my inquiry of the person or persons who manage the system, or those persons directly responsible for gathering the information, the information submitted is, to the best of my knowledge and belief, true, accurate, and complete. I am aware that there are significant penalties for submitting false information, including the possibility of fine and imprisonment for knowing violations.

\_\_\_\_\_  
Authorized Signature

**CONTACT INFORMATION**

The following personnel are duly authorized representatives and have signatory authority for modifications made to the SWPPP:

➤ **Contractor Information:**

- Prime Contractor Name: \_\_\_\_\_
- Contractor Contact Name: \_\_\_\_\_
- Address: \_\_\_\_\_
- \_\_\_\_\_
- City: \_\_\_\_\_ State: \_\_\_\_\_ Zip: \_\_\_\_\_
- Office Phone: \_\_\_\_\_ Field: \_\_\_\_\_
- Cell Phone: \_\_\_\_\_ Fax: \_\_\_\_\_

➤ **Erosion Control Supervisor**

- Name: \_\_\_\_\_
- Address: \_\_\_\_\_
- \_\_\_\_\_
- City: \_\_\_\_\_ State: \_\_\_\_\_ Zip: \_\_\_\_\_
- Office Phone: \_\_\_\_\_ Field: \_\_\_\_\_
- Cell Phone: \_\_\_\_\_ Fax: \_\_\_\_\_

➤ **SDDOT Project Engineer**

- Name: \_\_\_\_\_
- Business Address: \_\_\_\_\_
- Job Office Location: \_\_\_\_\_
- City: \_\_\_\_\_ State: \_\_\_\_\_ Zip: \_\_\_\_\_
- Office Phone: \_\_\_\_\_ Field: \_\_\_\_\_
- Cell Phone: \_\_\_\_\_ Fax: \_\_\_\_\_

➤ **SDDANR Contact Spill Reporting**

- Business Hours Monday-Friday (605) 773-3296
- Nights and Weekends (605) 773-3231

➤ **SDDANR Contact for Hazardous Materials.**

- (605) 773-3153

➤ **National Response Center Hotline**

- (800) 424-8802.

➤ **SDDANR Stormwater Contact Information**

- SDDANR Stormwater (800) 737-8676
- Surface Water Quality Program (605) 773-3351

**5.5: REQUIRED SWPPP MODIFICATIONS**

➤ **5.5 (1): Conditions Requiring SWPPP Modification**

The SWPPP must be modified, including the site map(s), in response to any of the following conditions:

- When a new operator responsible for implementation of any part the SWPPP begins work on the site.
- When changes to the construction plans, sediment and erosion control measures, or any best management practices on site that are no longer accurately reflected in the SWPPP. This includes changes made in response to corrective actions triggered by inspections.
- To reflect areas on the site map where operational control has been transferred (including the date of the transfer) or has been covered under a new permit since initiating coverage under this general permit.
- If inspections by site staff, local officials, SDDANR, or U.S. EPA determine that SWPPP modifications are necessary for compliance with the Stormwater Permit.
- To reflect any revisions to applicable federal, state, or local requirements that affect the control measures implemented at the site.
- If approved by the Secretary, to reflect any changes in chemical water treatment systems or controls, including the use of a different water treatment chemical, age rates, different areas, or methods of application.

➤ **5.5 (2): Deadlines for SWPPP Modification**

Any required revisions to the SWPPP must be completed within 7 calendar days following any of the items listed above.

➤ **5.5 (3): Documentation of Modifications to the Plan**

All SWPPP modification records are required to be maintained showing the dates of when the modification occurred. The records must include the name of the person authorizing each change and a brief summary of all changes.

➤ **5.5 (4): Certification Requirements**





























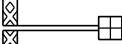

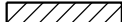
All modifications made to the SWPPP must be signed and certified as required in Section 7.4.

➤ **5.5 (5): Required Notice to Other Operators**

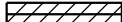
If there are multiple operators at the site, the Contractor's Erosion Control Supervisor must notify each operator that may be impacted by the change to the SWPPP within 24 hours.

When modifications as described above occur, the SWPPP will be modified to provide appropriate protection to disturbed areas, all storm water structures, and adjacent waters. The SDDOT Project Engineer will modify the SWPPP using the DOT 298 form and drawings on the plan will be modified to reflect the needed changes. Copies of the DOT 298 forms and the SWPPP will be retained on site in a designated place for review throughout the course of the project. A copy of the DOT 298 form will be given to the Contractor Erosion Control Supervisor and a copy will be emailed to the SDDOT Environmental Section in accordance with the DOT 298 Form.

# EROSION AND SEDIMENT CONTROL LEGEND

-  Silt Fence J-Hooks
-  Low Flow Silt Fence
-  High Flow Silt Fence
-  High Flow Silt Fence at Pipe
-  Sediment Control at Inlet After Placement of Surfacing
-  Sediment Control at Inlet Before Placement of Surfacing
-  Temporary Sediment Barrier
-  Temporary Water Barrier
-  Floating Silt Curtain
-  Sediment Filter Bags
-  Triangular Silt Barriers
-  Erosion Control Wattles on Slopes
-  Erosion Control Wattles at Inlets
-  Erosion Control Wattles in Ditches
-  Erosion Bales
-  Surfacing Roughening
-  Temporary Grass Hay or Straw Mulch/ Soil Stabilizer
-  Cut Interceptor Ditch
-  Temporary Slope Drain
-  Bonded Fiber Matrix/ Fiber Reinforced Matrix
-  Rock Check Dam
-  Type 1 Erosion Control Blanket
-  Type 2 Erosion Control Blanket
-  Type 3 Erosion Control Blanket
-  Type 4 Erosion Control Blanket
-  Type 1 Turf Reinforcement Mat
-  Type 2 Turf Reinforcement Mat
-  Type 3 Turf Reinforcement Mat
-  Transition Mat
-  Articulated Concrete Matress
-  Silt Trap (See Standard Plate 734.04)

## BEST MANAGEMENT PRACTICES

Best Management Practices (BMPs) are split into three categories and are to be used throughout construction.

### INITIAL PHASE

BMPs from the Legend shown as Orange Symbols on the Erosion and Sediment Control Plan Sheets are to be installed in the Initial Phase prior to earth disturbing activities and remain in place for the Intermediate Phase for temporary stabilization and in the Final Phase to achieve final stabilization.

### INTERMEDIATE PHASE

BMPs from the Legend shown as Blue Symbols on the Erosion and Sediment Control Plan Sheets are to be installed in the Intermediate Phase for temporary stabilization and remain in place in the Final Phase to achieve final stabilization.

### FINAL PHASE

BMPs from the Legend shown as Green Symbols on the Erosion and Sediment Control Plan Sheets are to be installed in the Final Phase to achieve final stabilization.

If these items are applicable they are to be shown in the updated SWPPP using the Symbols given.

- |   |  |
|---|--|
|  TS Topsoil Stockpile  |  M On-Site Construction Material Storage Area |
|  B Borrow Area  |  SK Spill Kit                                |
|  CE Stabilized Construction Entrance                                     |  WP Work Platform                           |
|  VB Vegetated Buffer Strip   |  CC Cover Crop Seeding                      |
|  CW Concrete Washout   |  PT Portable Toilet                         |
|  AP Asphalt Plant Site   |  |
|  CP Concrete Plant Site  |  |
|  V Vehicle and Equipment Parking Area, Fueling Area, or Maintenance Area |  |
|  D Dumpster or other Trash and Debris Containers                         |  |

# EROSION CONTROL LAYOUT

## US 16B - Dan Christy Ln

SD DOT	PROJECT	SECTION	SHEET
	NH 016B(03)64	D	9
Plotting Date: 2/13/2026			

Install 12" Diameter Erosion Control  
Wattles at the following locations:

1+85 to 6+10 L Across Highway Ditch spaced 75' (210 ft)

Install High Flow Silt Fence  
at the following Locations:

7+15 L Perimeter Control Across Ditch (45 ft)

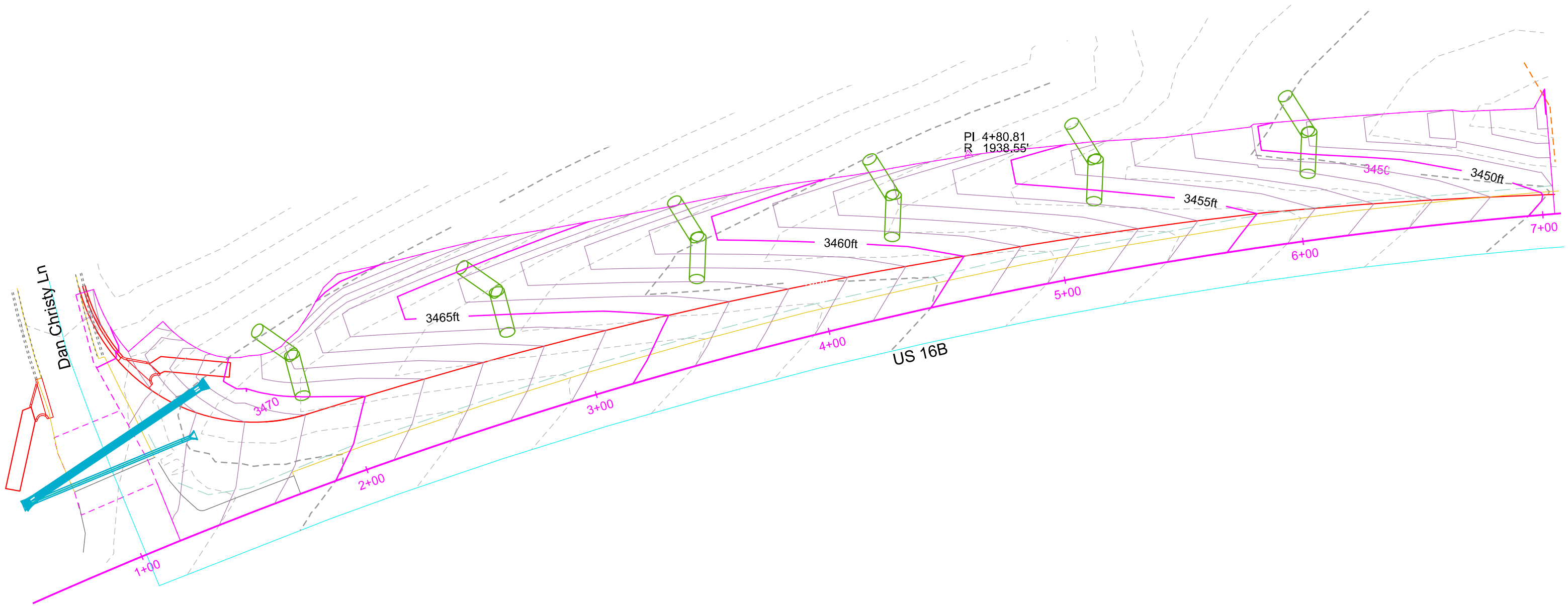

Dan Christy Ln Erosion Control Plan  
US 16B 1"=40'

— Edge of Surfacing



# EROSION CONTROL LAYOUT

## US 16B - SD 79 S



PROJECT	SECTION	SHEET
NH 016B(03)64	D	10

Plotting Date: 2/13/2026

Install Type 2 Turf Reinforcement Mat  
at the following locations:

5+12 to 5+92 R Ditch Bottom (142 SqYd)

Install High Flow Silt Fence  
at the following Locations:

5+52 R Pipe Inlet (40 ft)

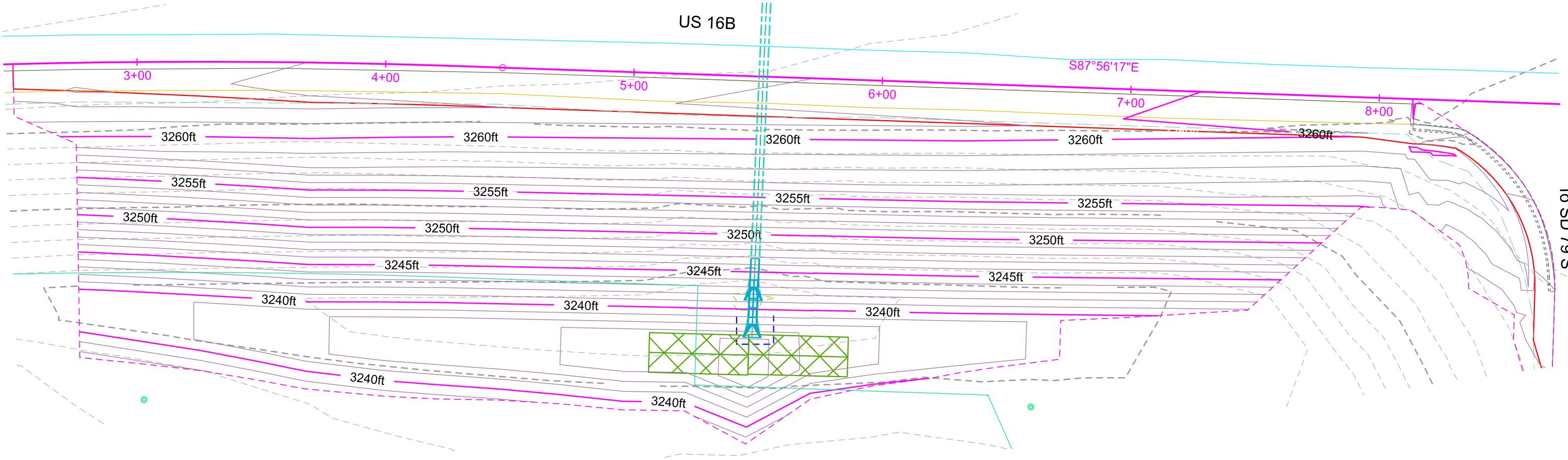

SD 79 S	Erosion Control Plan
US 16B	1"=40'

Edge of Surfacing



# EROSION CONTROL LAYOUT

## US 16B - Cambell Street



PROJECT	SECTION	SHEET
NH 016B(03)64	D	11

Plotting Date: 2/13/2026

Install High Flow Silt Fence  
at the following locations:  
2+30 to 8+50 R Perimeter Control (630 ft)

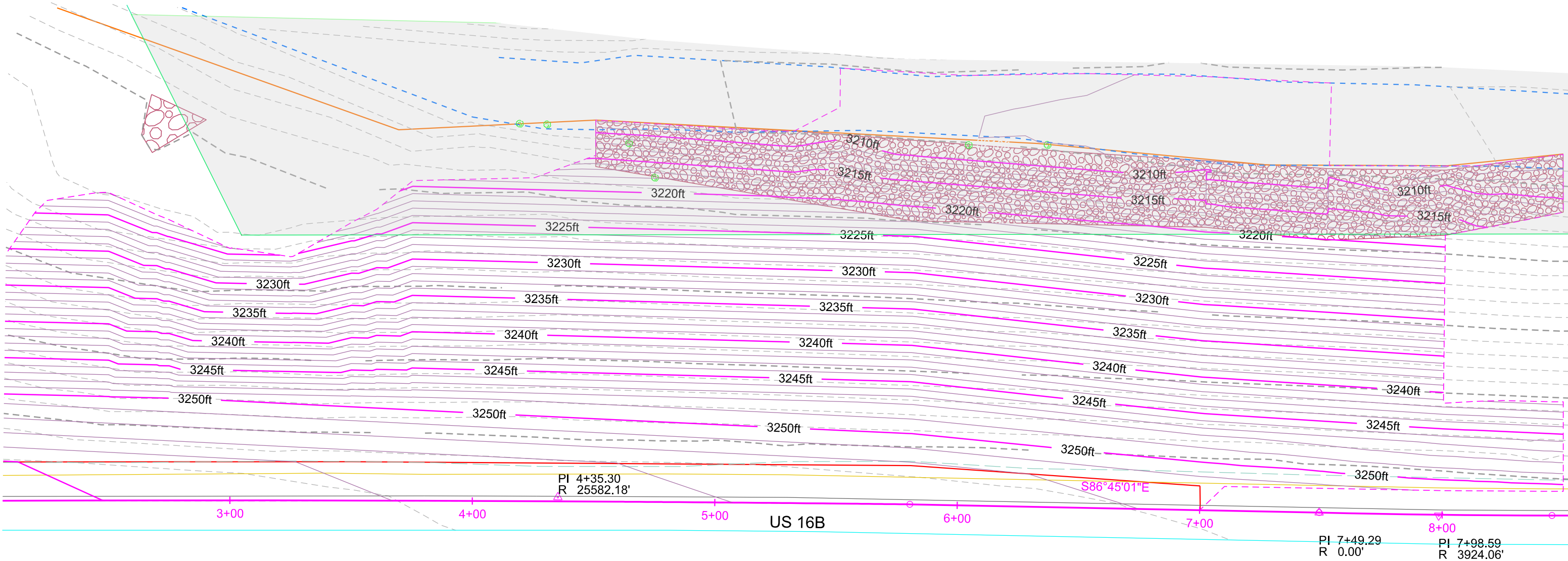

Cambell St Erosion Control Plan  
US 16B 1"=40'

Edge of Surfacing



# EROSION CONTROL LAYOUT

## US 16B - Creek Dr

	PROJECT	SECTION	SHEET
	NH 016B(03)64	D	12

Plotting Date: 2/13/2026

Install 12" Diameter Erosion Control  
Wattles at the following locations:  
8+90 R Across Highway Ditch (50 ft)

Install High Flow Silt Fence  
at the following Locations:  
3+75 L Perimeter Control Across Ditch (55 ft)

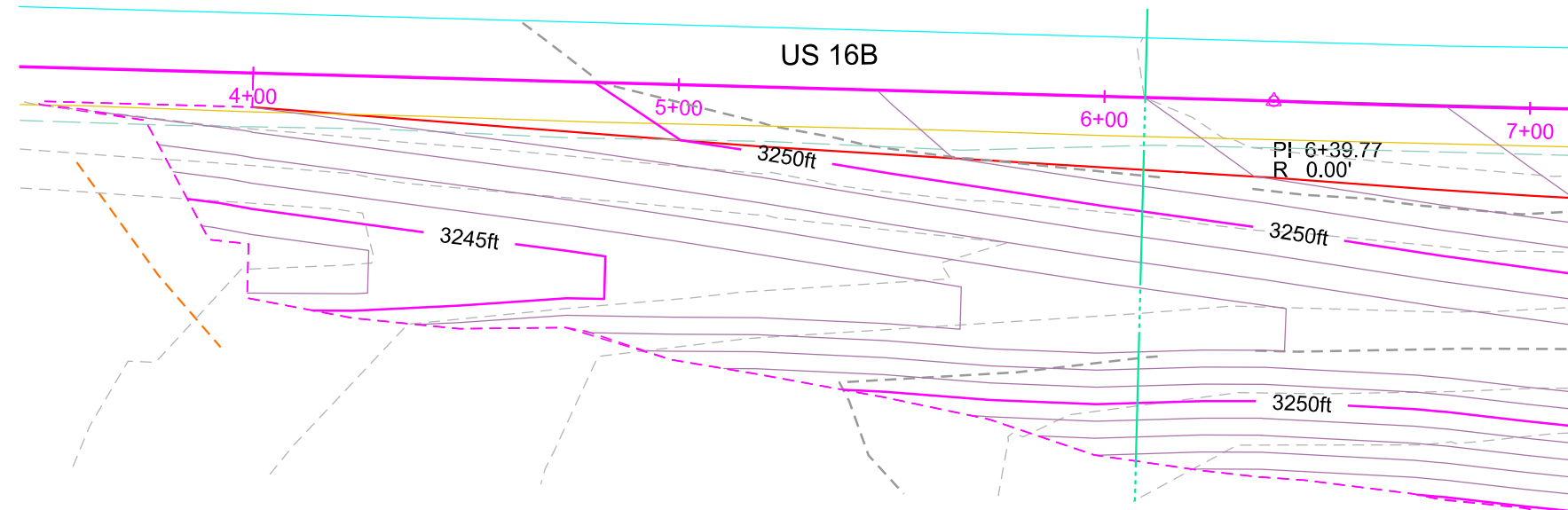

Creek Dr Erosion Control Plan  
US 16B 1"=40'

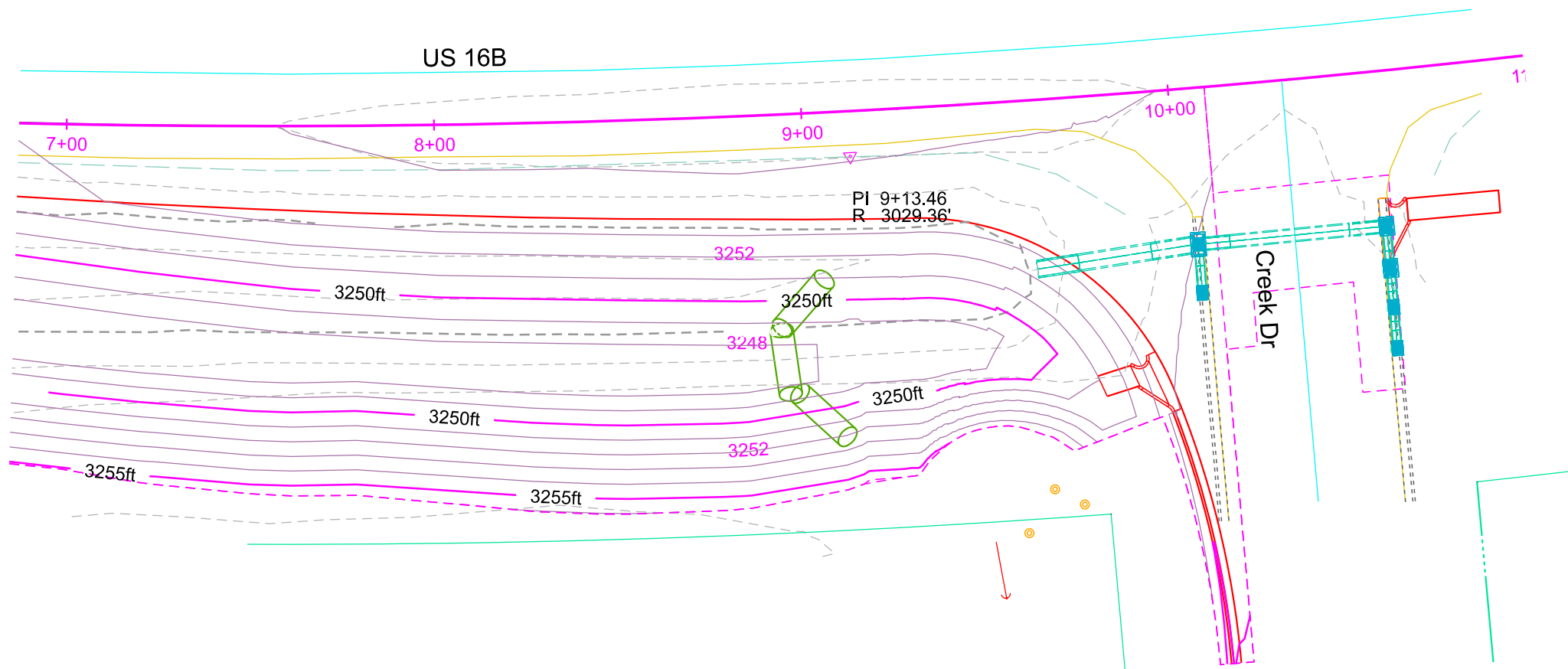

# EROSION CONTROL LAYOUT

SD DOT	PROJECT	SECTION	SHEET
	NH 016B(03)64	D	13

Plotting Date: 2/13/2026

## US 16B - Edwards St

Install High Flow Silt Fence  
at the following Locations:  
2+09 L Pipe Inlet (35 ft)

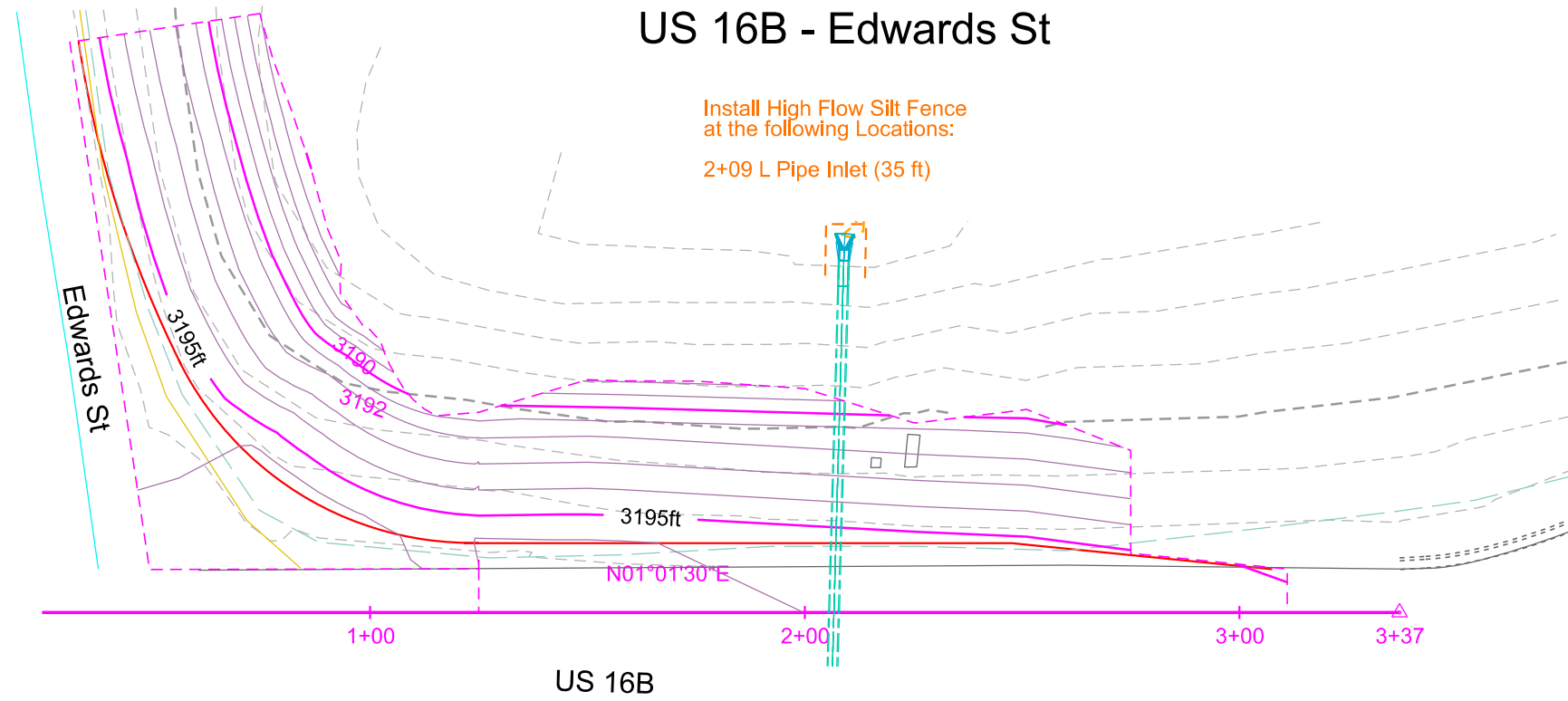
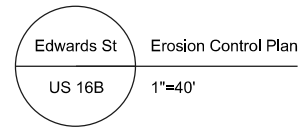

## US 16B - I90 Service Rd

Install 12" Diameter Erosion Control  
Wattles at the following locations:  
0+33 to 3+24 R Perimeter Control (325 ft)

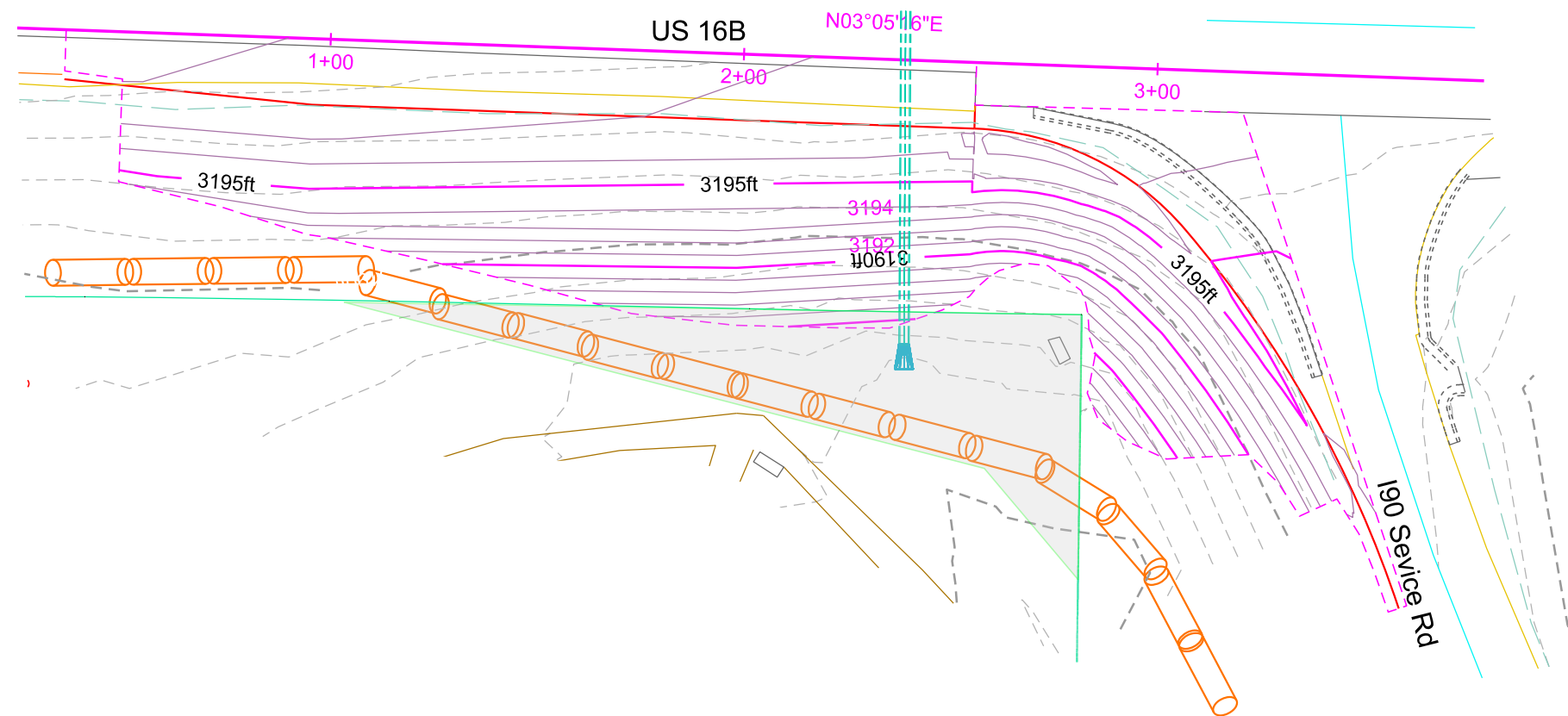
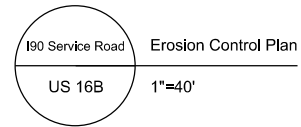

— Edge of Surfacing



### MANUAL HIGH FLOW SILT FENCE INSTALLATION



① EXCAVATE TRENCH

② DRIVE STEEL T FENCE POSTS

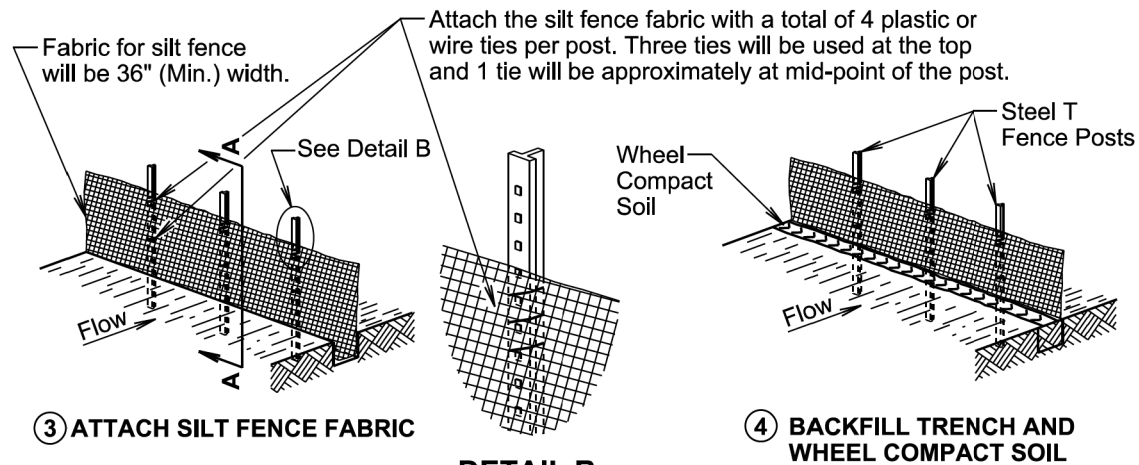

③ ATTACH SILT FENCE FABRIC

④ BACKFILL TRENCH AND WHEEL COMPACT SOIL

DETAIL B

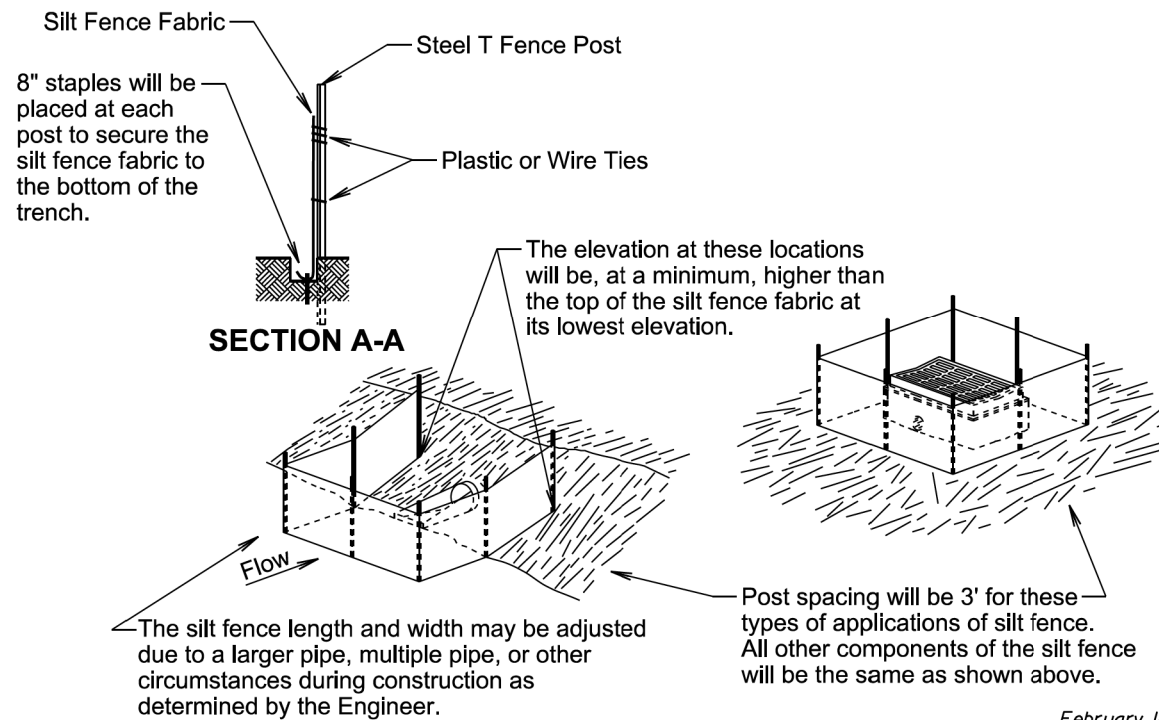

February 14, 2020

Published Date: 2026

SD  
DOT

HIGH FLOW SILT FENCE

PLATE NUMBER  
734.05

Sheet 1 of 2

### MACHINE SLICED HIGH FLOW SILT FENCE INSTALLATION

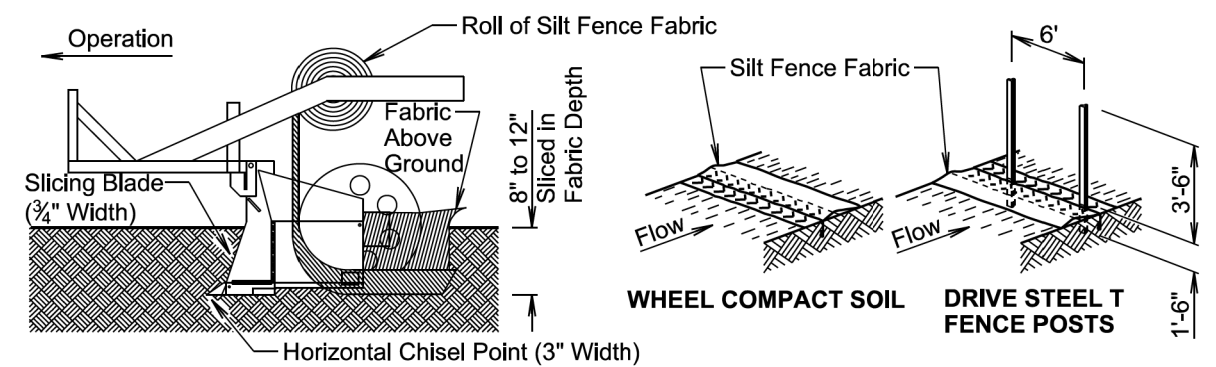

① INSTALL SILT FENCE FABRIC BY MACHINE SLICING METHOD.

② WHEEL COMPACT SOIL ABOVE SLICED IN PORTION OF FABRIC AND THEN DRIVE STEEL T FENCE POSTS.

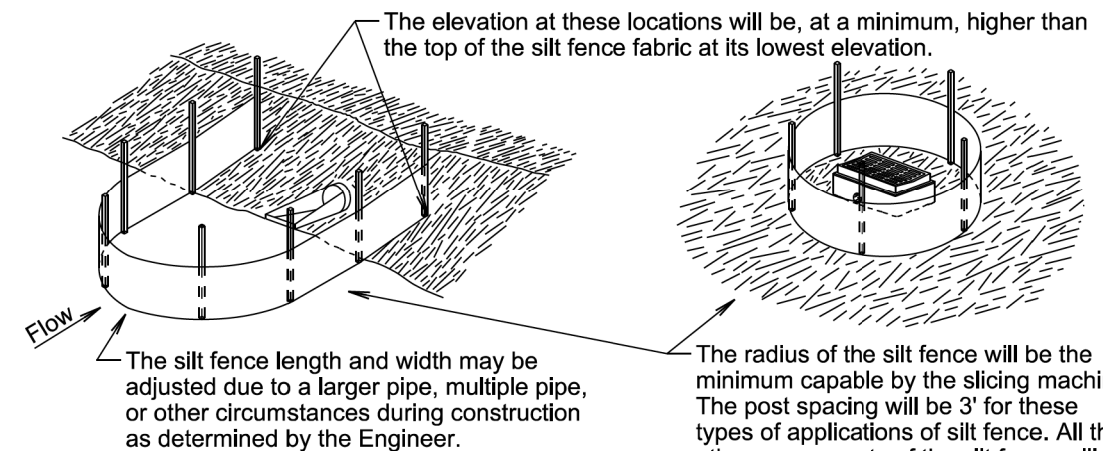
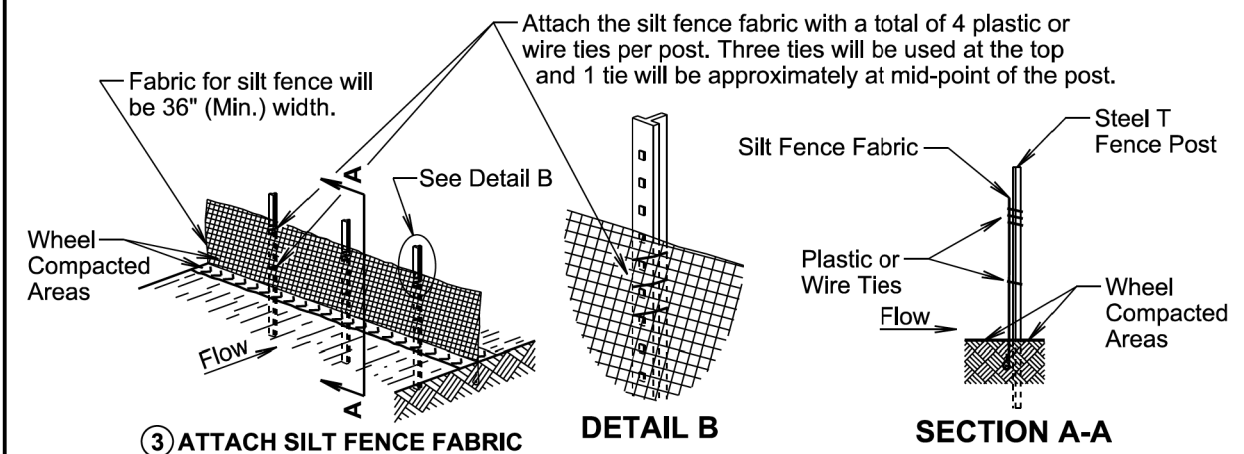

**GENERAL NOTE:**

If a trench can not be dug or the silt fence fabric can not be sliced in due to the type of earthen material (such as rock), then a row of 30 to 40 pound sandbags butted end to end will be provided on top of the extra length of silt fence fabric to prevent underflow.

February 14, 2020

Published Date: 2026

SD  
DOT

HIGH FLOW SILT FENCE

PLATE NUMBER  
734.05

Sheet 2 of 2

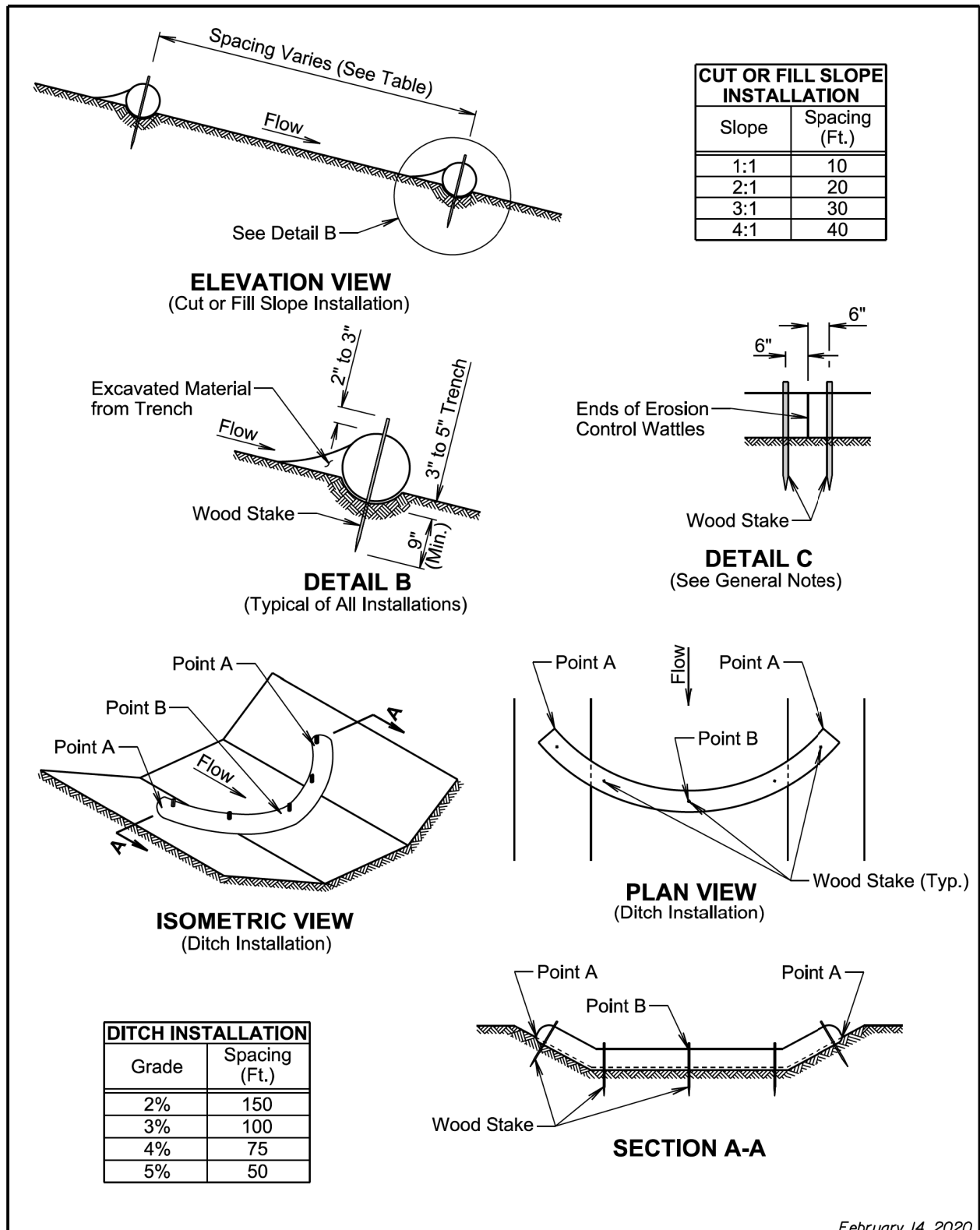

February 14, 2020

Published Date: 2026	SD DOT	EROSION CONTROL WATTLE	PLATE NUMBER 734.06
			Sheet 1 of 2

**GENERAL NOTES:**

At cut or fill slope installations, wattles will be installed along the contour and perpendicular to the water flow.

At ditch installations, point A must be higher than point B to ensure that water flows over the wattle and not around the ends.

The Contractor will dig a 3" to 5" trench, install the wattle tightly in the trench so that daylight can not be seen under the wattle, and then compact the soil excavated from the trench against the wattle on the uphill side. See Detail B.

The stakes will be 1"x2" or 2"x2" wood stakes, however, other types of stakes such as rebar may be used only if approved by the Engineer. The stakes will be placed 6" from the ends of the wattles and the spacing of the stakes along the wattles will be 3' to 4'.

Where installing running lengths of wattles, the Contractor will butt the second wattle tightly against the first and will not overlap the ends. See Detail C.

The Contractor and Engineer will inspect the erosion control wattles in accordance with the storm water permit. The Contractor will remove, dispose, or reshape the accumulated sediment when necessary as determined by the Engineer.

Sediment removal, disposal, or necessary shaping will be as directed by the Engineer. All costs for removing accumulated sediment, disposal of sediment, and necessary shaping will be incidental to the contract unit price per cubic yard for "Remove Sediment".

All costs for furnishing and installing the erosion control wattles including labor, equipment, and materials will be incidental to the contract unit price per foot for the corresponding erosion control wattle contract item.

All costs for removing the erosion control wattle from the project including labor, equipment, and materials will be incidental to the contract unit price per foot for "Remove Erosion Control Wattle".

February 14, 2020

Published Date: 2026	SD DOT	EROSION CONTROL WATTLE	PLATE NUMBER 734.06
			Sheet 2 of 2