

SECTION F: SURFACING PLANS

SD DOT	PROJECT	SECTION	SHEET
	NH 016B(03)64	F	1

Plotting Date: 2/13/2026

INDEX OF SHEETS

F1	General Layout with Index
F2-F3	Estimate With General Notes & Tables
F4-F10	Typical Surfacing Sections
F11-F17	Surfacing Layout
F18-F23	Standard Plates

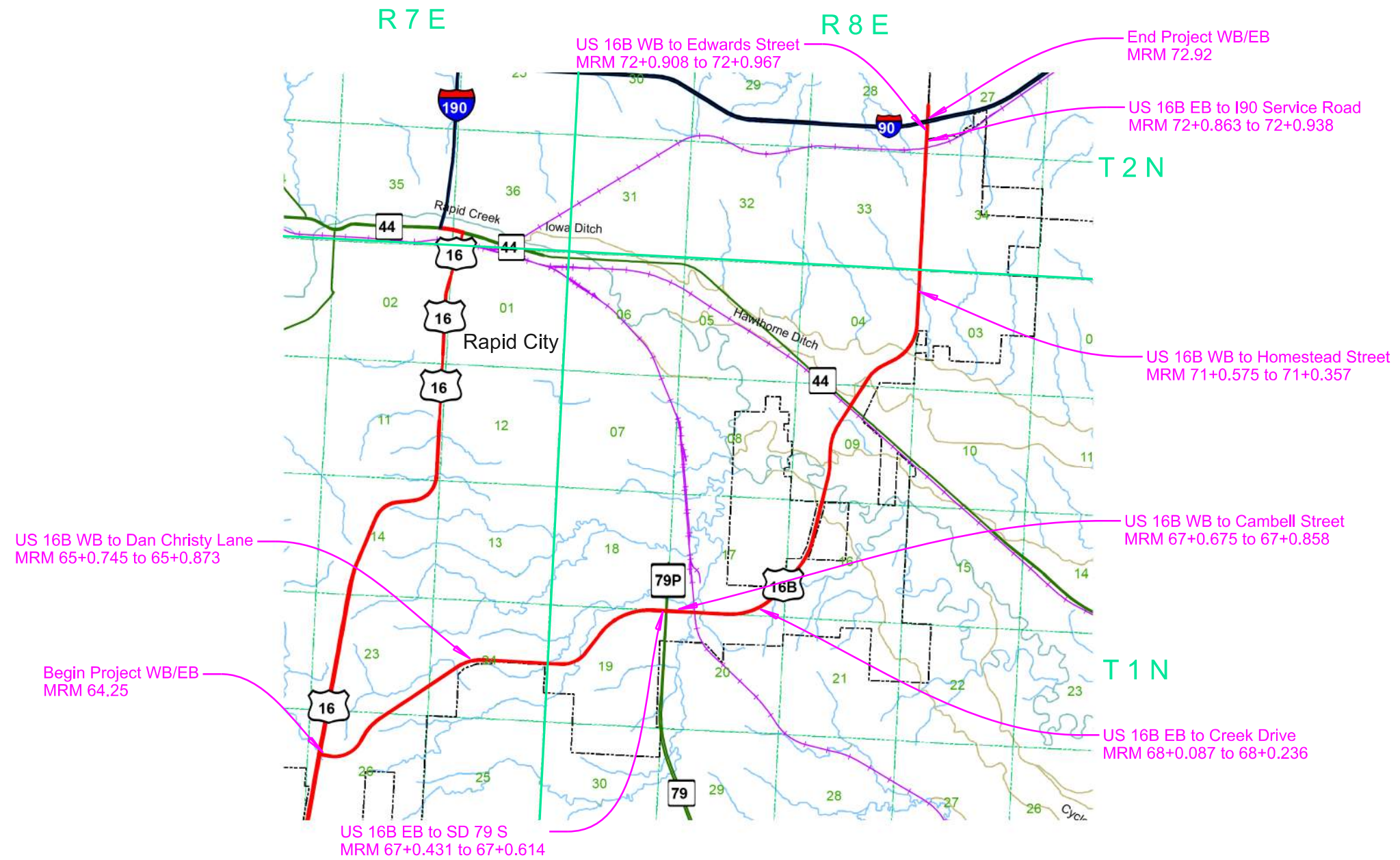

SECTION F – ESTIMATE OF QUANTITIES

BID ITEM NUMBER	ITEM	QUANTITY	UNIT
120E6200	Water for Granular Material	40.3	MGal
260E1010	Base Course	728.0	Ton
260E2010	Gravel Cushion	2,630.9	Ton
320E1200	Asphalt Concrete Composite	473.7	Ton
380E0060	8.5" Nonreinforced PCC Pavement	1,407.3	SqYd
380E0080	9.5" Nonreinforced PCC Pavement	4,367.9	SqYd
380E2564	4" Barrier Type Colored Median PCC Pavement	197.0	SqYd
380E6000	Dowel Bar	2,160	Each
380E6110	Insert Steel Bar in PCC Pavement	1,371	Each

SURFACING THICKNESS DIMENSIONS

At those locations where material must be placed to achieve a required elevation, the depth/quantity may be varied to achieve the required elevation.

RECYCLED CONCRETE AGGREGATE (RCA)

Portland cement concrete pavement (RCA) removed from the mainline within the project limits may be crushed and reused as granular material provided it meets the requirements for the granular material it is replacing.

All in-place rebar will be separated and removed from the RCA.

There is an estimated 203 tons of PCC Pavement on this project that can be crushed and reused. This quantity is based on a unit weight of 118 lbs. per cubic foot for the recycled concrete aggregate.

The Contractor will dispose of the material (including existing rebar) not utilized on the project at a site approved by the Engineer.

Payment for the recycled concrete aggregate will be at the contract unit price per ton for the granular material that it is replacing.

8.5" NONREINFORCED PCC PAVEMENT

The aggregate may require screening as determined by the Engineer.

The concrete mix used in the PCC Pavement will conform to Section 380.

In lieu of an automatic subgrader operating from a preset line, a motor grader or other suitable equipment may be used to trim the gravel cushion to final grade prior to placement of concrete. There will be no direct payment for trimming of the gravel cushion for PCC pavement. The trimming will be considered incidental to the related items required for PCC Pavement.

A construction joint will be sawed whenever new concrete pavement is placed adjacent to existing concrete pavement.

The transverse construction joints will be handled in accordance with Standard Plate 380.15.

Unless specified otherwise in the PCC Pavement Joint Layout Sheet or elsewhere in the plans, the transverse joints for the 8.5" Nonreinforced PCC Pavement will match existing PCC joints.

Unless specified otherwise in the PCC Pavement Joint Layout Sheet or elsewhere in the plans, the typical joint spacing for the 8.5" Nonreinforced PCC Pavement will match existing PCC joints.

The location of joints, as shown and designated on the PCC Pavement Joint Layout(s) are only approximate locations to be used as a guide and to afford bidders a basis for estimating the construction cost of the joints. The final locations of the joints are to be designated by the Engineer during construction.

Longitudinal and transverse joints will be sealed with Hot Poured Elastic Joint Sealer

All driving surfaces of the mainline paving and auxiliary lanes will be longitudinally tined from 6" each side of centerline pavement markings to 6" inside the outside pavement markings. All other areas will be textured as directed by the Engineer.

9.5" NONREINFORCED PCC PAVEMENT

The aggregate may require screening as determined by the Engineer.

The concrete mix used in the PCC Pavement will conform to Section 380.

In lieu of an automatic subgrader operating from a preset line, a motor grader or other suitable equipment may be used to trim the gravel cushion to final grade prior to placement of concrete. There will be no direct payment for trimming of the gravel cushion for PCC pavement. The trimming will be considered incidental to the related items required for PCC Pavement.

A construction joint will be sawed whenever new concrete pavement is placed adjacent to existing concrete pavement.

The transverse construction joints will be handled in accordance with Standard Plate 380.15.

Unless specified otherwise in the PCC Pavement Joint Layout Sheet or elsewhere in the plans, the transverse joints for the 9.5" Nonreinforced PCC Pavement will match existing PCC joints.

Unless specified otherwise in the PCC Pavement Joint Layout Sheet or elsewhere in the plans, the typical joint spacing for the 9.5" Nonreinforced PCC Pavement will match existing PCC joints.

The location of joints, as shown and designated on the PCC Pavement Joint Layout(s) are only approximate locations to be used as a guide and to afford bidders a basis for estimating the construction cost of the joints. The final locations of the joints are to be designated by the Engineer during construction.

Longitudinal and transverse joints will be sealed with Hot Poured Elastic Joint Sealer

All driving surfaces of the mainline paving and auxiliary lanes will be longitudinally tined from 6" each side of centerline pavement markings to 6"

inside the outside pavement markings. All other areas will be textured as directed by the Engineer.

STEEL BAR INSERTION

The Contractor will insert the Steel Bars into drilled holes in the existing concrete pavement. Anchoring of the steel bars in the drilled holes will conform to the Specifications.

The steel bars will be cut to the specified length by sawing or shearing and will be free from burring or other deformations.

Epoxy coated plain round 1¼" steel bars will be inserted on 12-inch centers in the transverse joint. The first steel bar will be placed a minimum of 3 inches and a maximum of 6 inches from the outside edge of the slab.

Epoxy coated deformed No. 5 steel bars will be inserted on 30-inch centers in the longitudinal joint and will be placed a minimum of 15 inches from the existing transverse contraction joint.

ASPHALT CONCRETE COMPOSITE

Asphalt Concrete Composite will include MC-70 Asphalt for Prime placed at the rate of 0.30 gallons per square yard. The Asphalt for Prime will be applied to the Base Course for the full width of the bottom layer of Asphalt Concrete Composite plus one foot additional on the outside shoulder.

Asphalt for tack SS-1h or CSS-1h will be applied prior to each lift of Asphalt Concrete Composite. Asphalt for tack will be applied at a rate of 0.09 gallons per square yard on existing pavement or milled asphalt concrete surfaces and at a rate of 0.06 gallons per square yard on primed base course or new asphalt concrete pavement. The Asphalt for tack will be applied for the full width of the bottom layer of Asphalt Concrete Composite plus one-half foot additional on the outside shoulder.

4" BARRIER TYPE COLORED MEDIAN PCC PAVEMENT

The colored concrete will have the integral color Solomon Sand #775 or an equal approved by the Engineer.

ColorFlo Liquid Color
Solomon Colors, Inc.
www.solomoncolors.com

Sand requires a rate of 6.25 lbs of Solomon Sand #775 per cubic yard of concrete. The colored concrete must be cured according to the manufacturer's recommendations with two coats of a non-yellowing acrylic curing and sealing compound. The curing and sealing compound will meet ASTM C309 specification. The curing and sealing product will be (DECRA-SEAL) or an equal approved by the Engineer.

DECRA-SEAL
W.R. Meadows, Inc.
1-800-342-5976
www.wrmeadows.com

4" BARRIER TYPE COLORED MEDIAN PCC PAVEMENT, CONTINUED

No white pigmented cure will be used. The Contractor will protect the colored concrete to insure no white pigmented curing compound comes in contact with the colored concrete. All costs for furnishing, handling, and applying the curing and sealing compound, and liquid integral color, including the materials, equipment, labor, and incidentals necessary will be incidental to the contract unit price for the colored concrete bid item.

JOINTS IN CONCRETE MEDIAN PAVEMENT

Transverse contraction joints in the median pavement will coincide with mainline transverse joints and be formed by means of a grooving tool, to a depth of at least 1/4 the thickness of the median pavement. Expansions joints will be formed at planned contraction joint locations.

CURING OF CONCRETE

Portland Cement Concrete Pavement, Concrete and Curb & Gutter will be cured with Linseed Oil Base Emulsion Compound. All costs for Curing of Concrete will be incidental to the contract unit price per various Portland Cement Concrete bid items.



TABLE OF SURFACING QUANTITIES

Location	Station to	Station	8.5" Nonreinforced PCC Pavement SqYd	9.5" Nonreinforced PCC Pavement SqYd	4" Barrier Type Colored Median PCC Pavement SqYd	1 1/4" Dowel Bars Each	Insert Steel Bar in PCC Pavement Each	Gravel Cushion Ton	Base Course Ton	Water for Granular Mgal	Asphalt Concrete Composite Ton
US16B/Dan Christy Lane	1+12	7+05	1407.3			677	257	570.8	104.4	8.1	68.0
US16B/SD79S	2+50	8+73		1074.2		342	280	510.4		6.1	
US16B/Cambell Street	0+74	7+00		1075		350	288	512.5		6.2	
US16B/Creek Drive	4+00	10+10		1123.1		401	210	472.9	381.8	10.3	247.5
US16B/Homestead Street	9+10	13+40		413.3	197	197	168	247.7		3.0	
US16B/I90 Service Road	0+36	3+65		371.6		107	92	172.1	116.2	3.5	76.0
US16B/Edwards Street	0+31	3+11		310.7		86	76	144.5	125.7	3.2	82.2
Totals:			1407.3	4367.9	197	2160	1371	2630.9	728.0	40.3	473.7

TYPICAL SURFACING SECTIONS

STATE OF SOUTH DAKOTA	PROJECT	SECTION	SHEET
		F	4

Plotting Date: 3/24/2026

-  Remove Asphalt Concrete Pavement
-  Unclassified Excavation

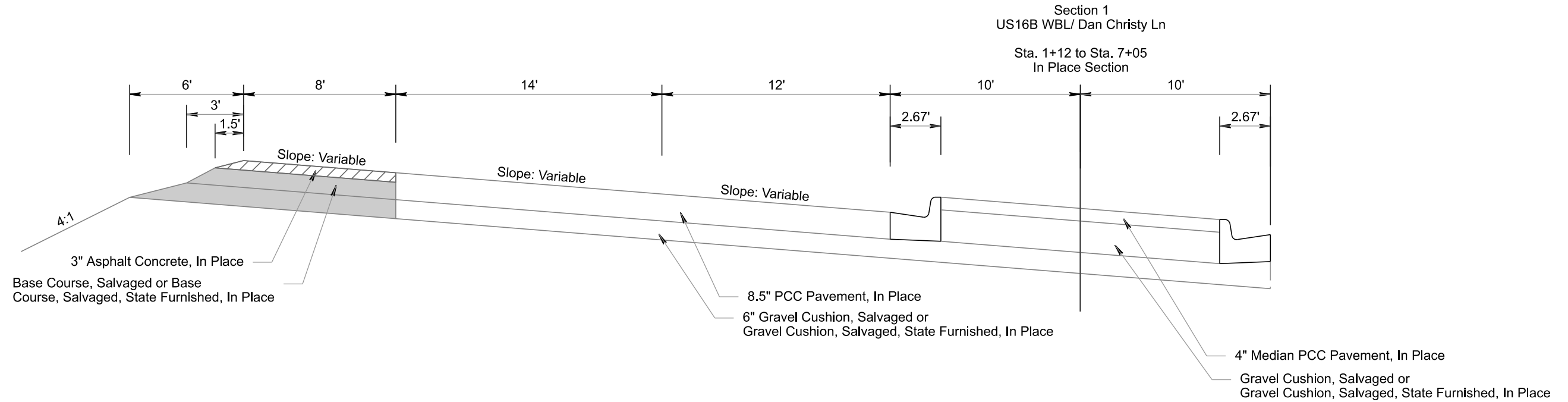

Transitions:

Sta. 1+85 to 4+60
* 16'

Sta. 4+60 to 5+85
* 18' to 14'

Sta. 5+85 to 7+05
* 14' to 8'

Sta. 1+85 to 4+60
** 14' to 2'

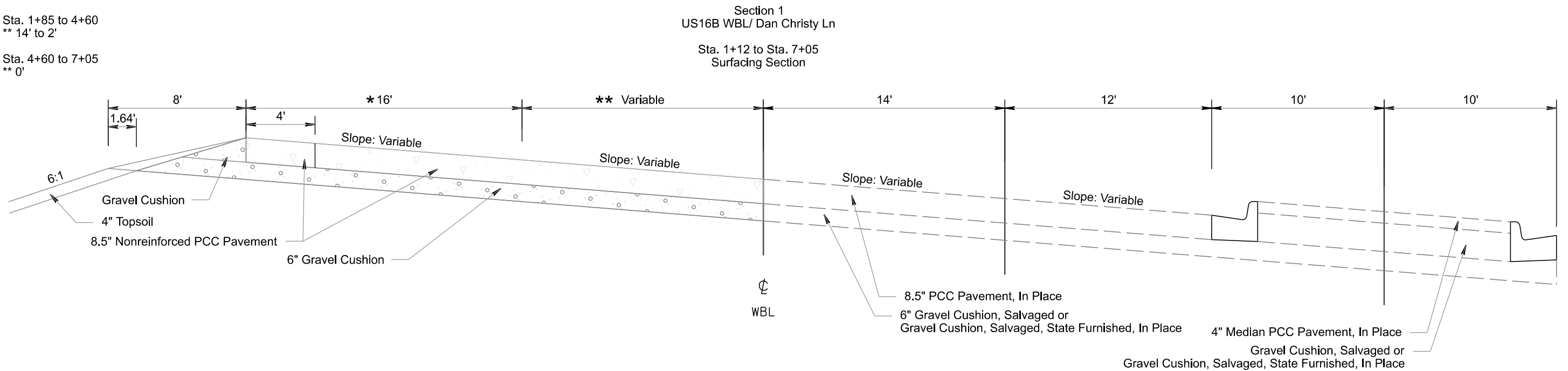

Sta. 4+60 to 7+05
** 0'



TYPICAL SURFACING SECTIONS

STATE OF SOUTH DAKOTA	PROJECT	SECTION	SHEET
		F	5

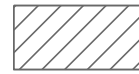
Plotting Date: 3/24/2026

-  Remove Asphalt Concrete Pavement
-  Remove Concrete Pavement
-  Unclassified Excavation

Section 2
US 16B EBL (US16B/SD79S)
Sta. 2+50 to Sta. 8+80
In Place Section

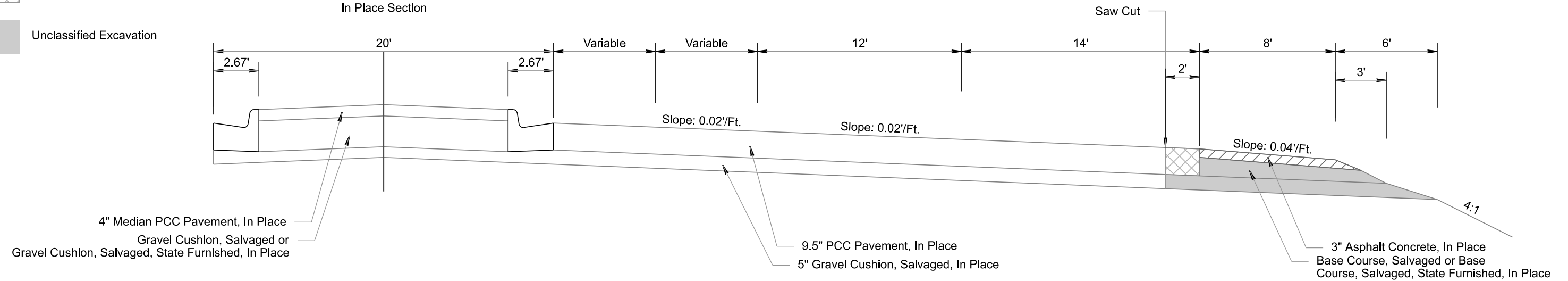

Section 2
US 16B EBL (US16B/SD79S)
Sta. 2+50 to Sta. 8+80
Surfacing Section

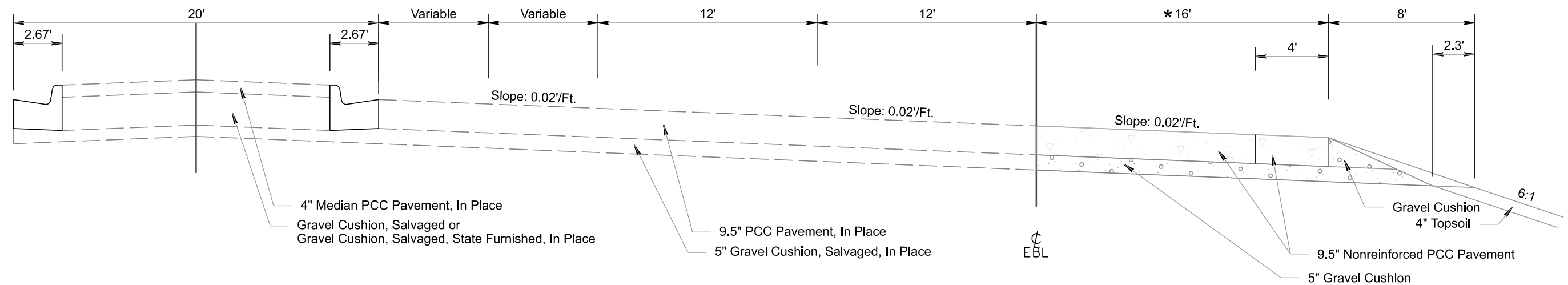

Transitions:
Sta. 2+50 to Sta. 3+70
* 10' to 16'



TYPICAL SURFACING SECTIONS

STATE OF SOUTH DAKOTA	PROJECT	SECTION	SHEET
		F	6

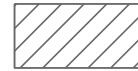
Plotting Date: 3/24/2026

-  Remove Asphalt Concrete Pavement
-  Unclassified Excavation

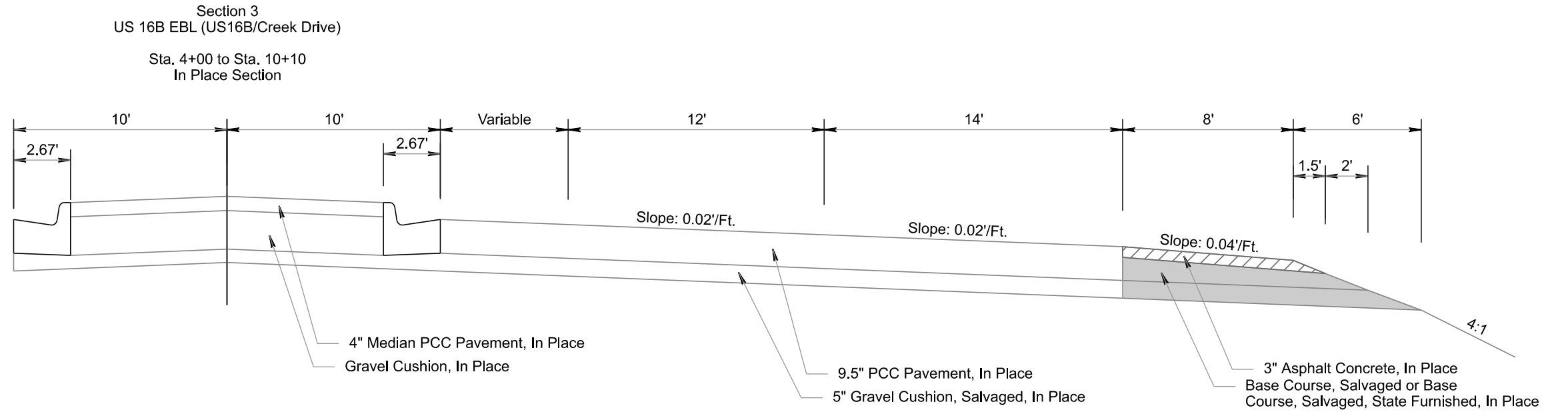

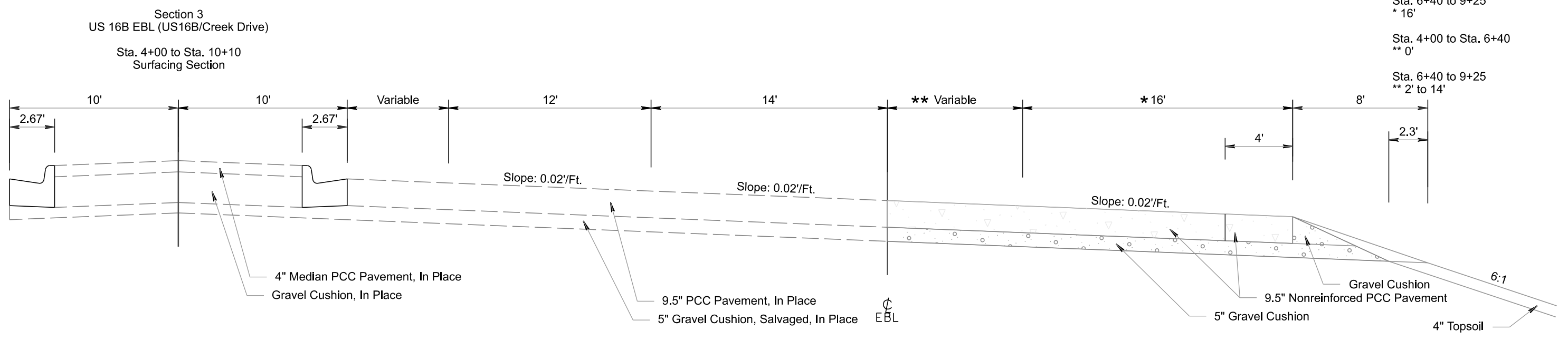

- Transitions:
- Sta. 4+00 to Sta. 5+20
* 8' to 14'
 - Sta. 5+20 to Sta. 6+40
* 14' to 18'
 - Sta. 6+40 to 9+25
* 16'
 - Sta. 4+00 to Sta. 6+40
** 0'
 - Sta. 6+40 to 9+25
** 2' to 14'



TYPICAL SURFACING SECTIONS

STATE OF SOUTH DAKOTA	PROJECT	SECTION	SHEET
		F	7

Plotting Date: 3/24/2026

-  Remove Asphalt Concrete Pavement
-  Remove Concrete Pavement
-  Unclassified Excavation

Section 4
US 16B WBL (US 16B/Cambell St.)
Sta. 0+74 to Sta. 7+00
In Place Section

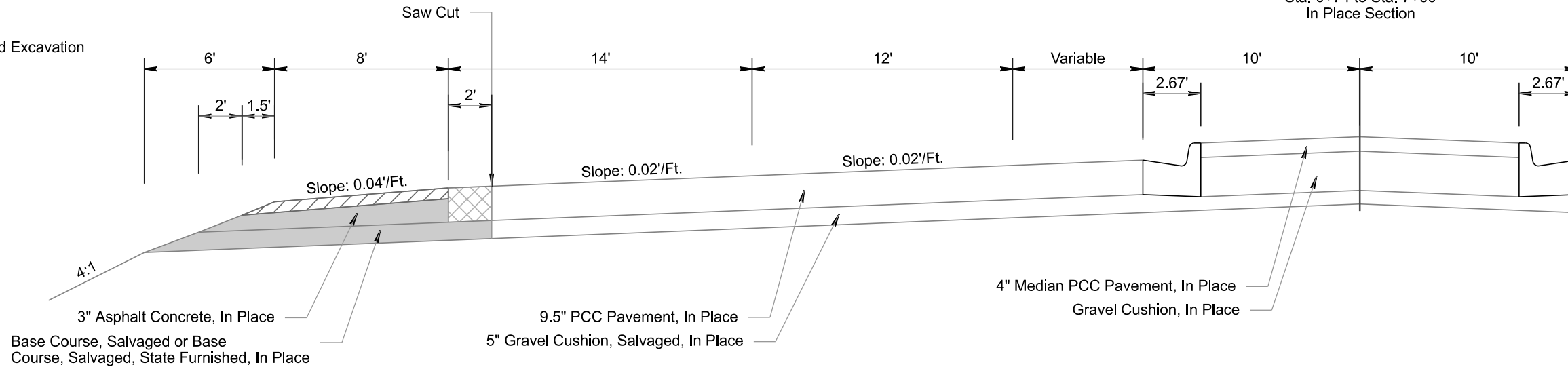

Section 4
US 16B WBL (US 16B/Cambell St.)
Sta. 0+74 to Sta. 7+00
Surfacing Section

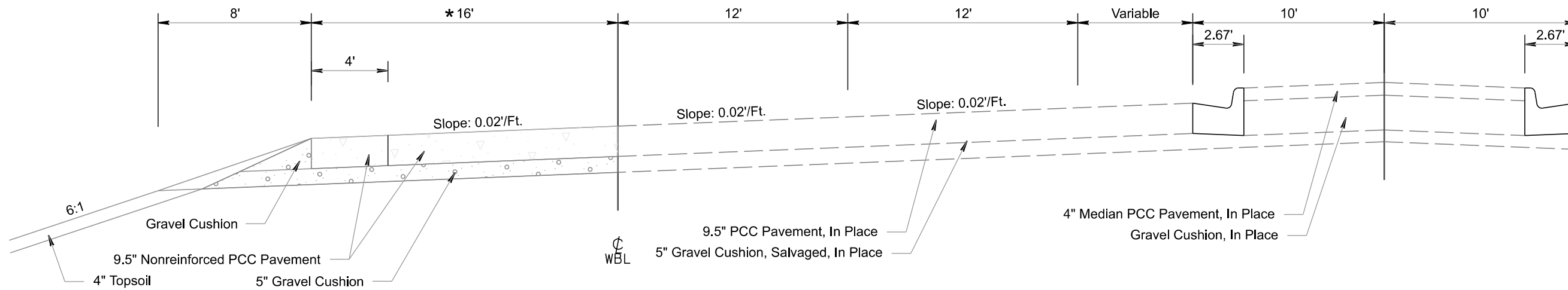

Transitions:
Sta. 5+80 to Sta. 7+00
* 16' to 10'



TYPICAL SURFACING SECTIONS

STATE OF SOUTH DAKOTA	PROJECT	SECTION	SHEET
		F	8

Plotting Date: 3/24/2026

 Remove Concrete Pavement
 Unclassified Excavation

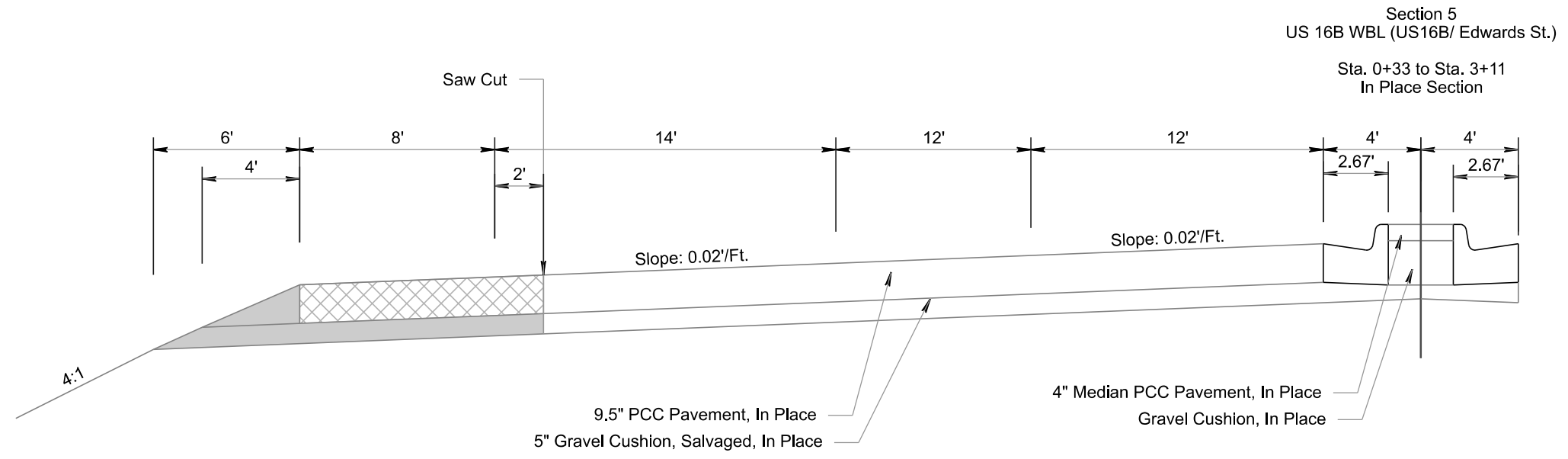

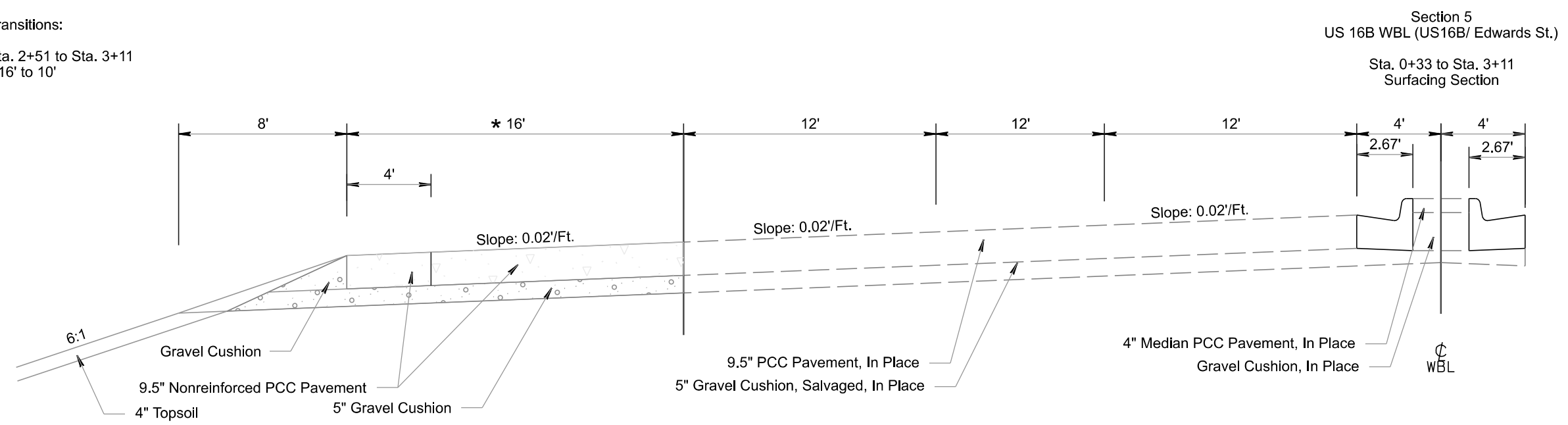

Transitions:
 Sta. 2+51 to Sta. 3+11
 * 16' to 10'



TYPICAL SURFACING SECTIONS

STATE OF SOUTH DAKOTA	PROJECT	SECTION	SHEET
		F	9

Plotting Date: 3/24/2026

-  Remove Asphalt Concrete Pavement
-  Remove Concrete Pavement
-  Unclassified Excavation

Section 6
US 16B EBL (US16B/I90 Service Rd.)

Sta. 0+36 to Sta. 3+66
In Place Section

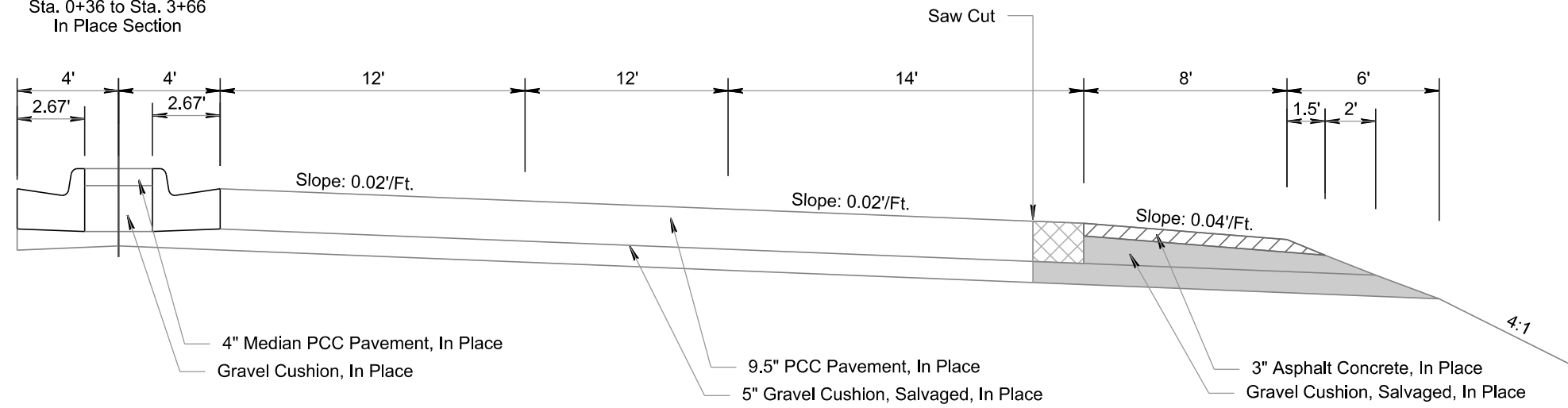

Section 6
US 16B EBL (US16B/I90 Service Rd.)

Sta. 0+36 to Sta. 3+66
Surfacing Section

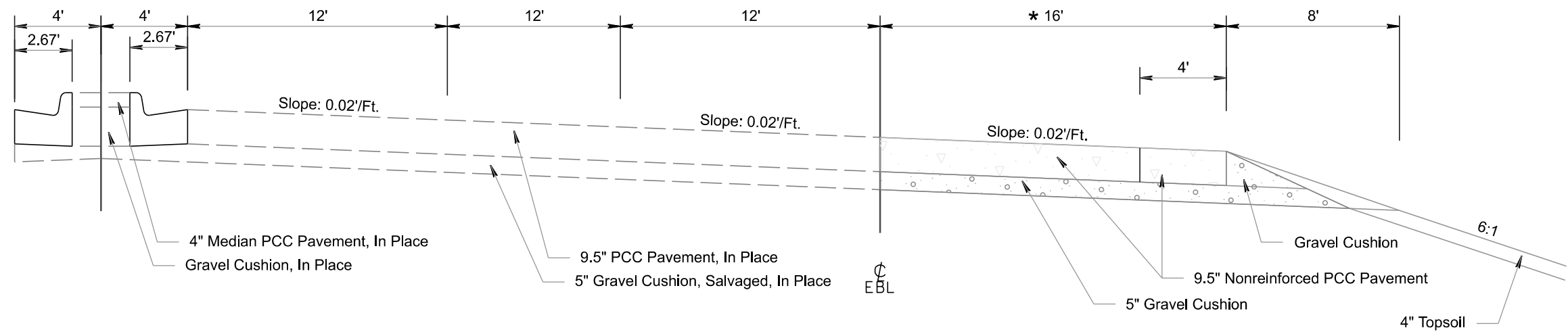

Transitions:
Sta. 0+36 to Sta. 0+96
* 10' to 16'



TYPICAL SURFACING SECTIONS

STATE OF SOUTH DAKOTA	PROJECT	SECTION	SHEET
		F	10

Plotting Date: 3/24/2026

-  Remove Concrete Pavement
-  Unclassified Excavation

Section 7
US 16B WBL (US16B/Homestead)
Sta. 9+10 to Sta. 13+30
In Place Section

Transitions:
Sta. 9+10 to Sta. 10+30
* 38' to 26'
2.66' to 14.66'

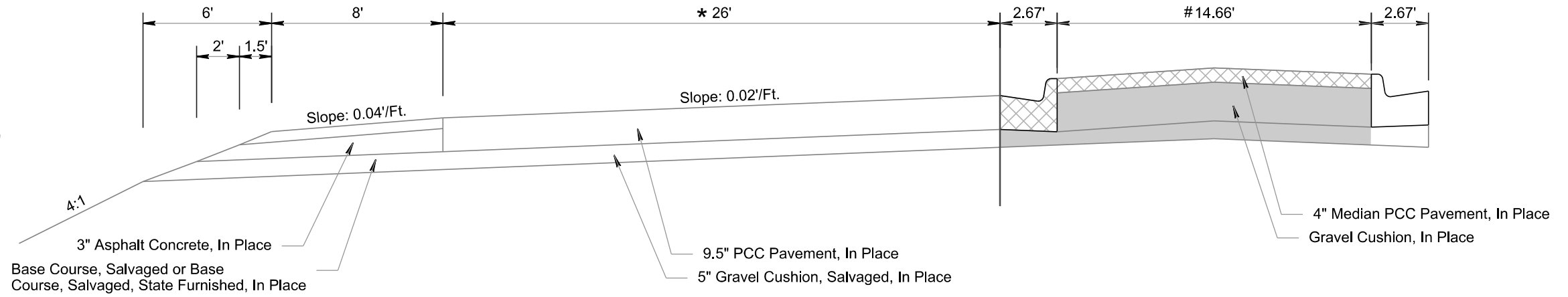

Section 7
US 16B WBL (US16B/Homestead)
Sta. 9+10 to Sta. 13+30
Surfacing Section

Transitions:
Sta. 9+10 to Sta. 10+30
* 0' to 12'
24' to 12'

Sta. 12+10 to Sta. 13+30
* 12' to 0'
** 5.33' to 17.33'

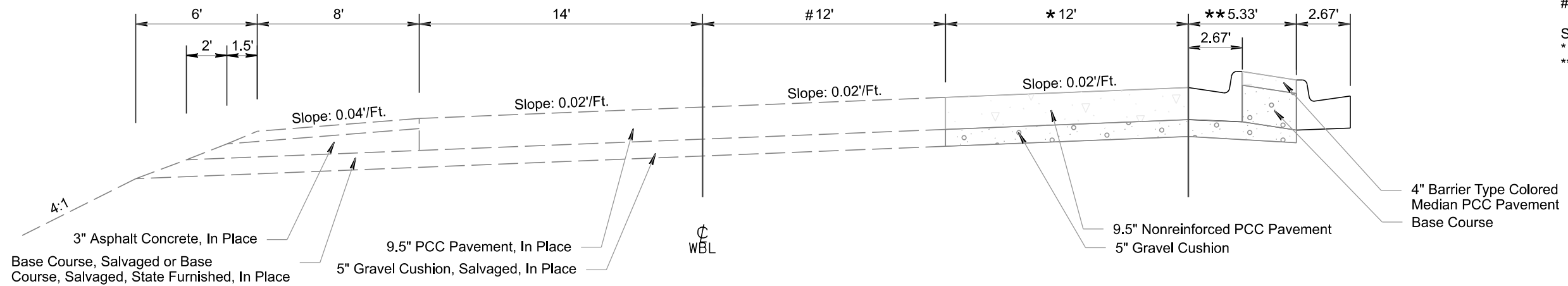

PCC PAVEMENT JOINT LAYOUT

US16B/Dan Christy Lane

SD DOT	PROJECT	SECTION	SHEET
	NH 016B(03)64	F	11

Plotting Date: 2/13/2026

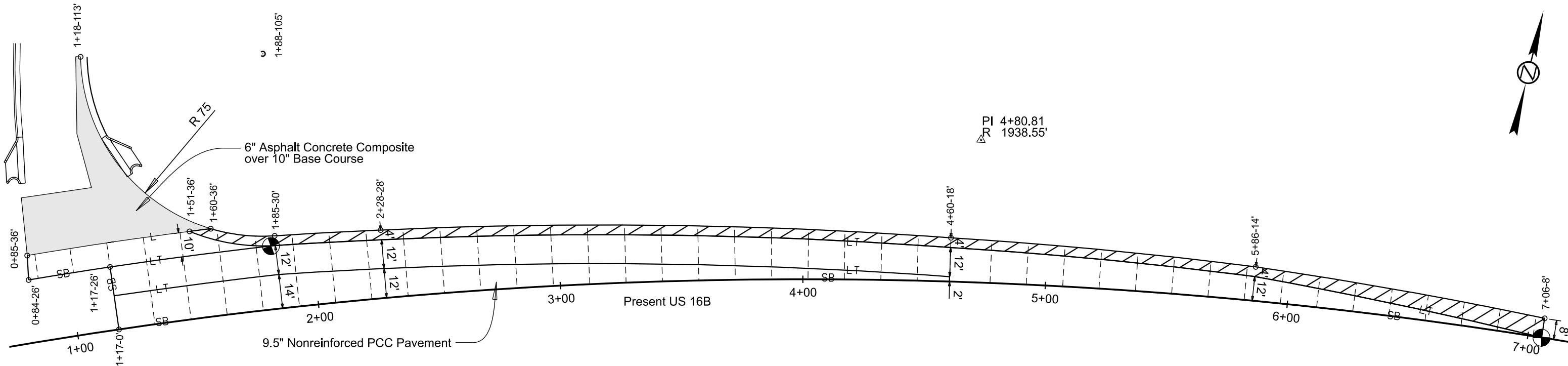

PI 4+80.81
R 1938.55'



Dan Christy Ln Pavement Layout
US 16B 1"=40'

LEGEND:

- Transverse Joint Spacing = Match Existing
- Longitudinal Joint With Tie Bars (Construction or Sawed) ——— LT ——— LT ———
- Longitudinal Joint Without Tie Bars ——— L ——— L ———
- Transverse Contraction Joint - - - - -
- Steel Bar Installation in Longitudinal or Transverse Joint ——— SB ——— SB ———
- Areas to be poured monolithically with adjacent slab ● (See Detail A)
- Areas to be poured monolithically with adjacent curb and gutter ⊕ (See Detail B)
- Transverse contraction joints within these areas shall not have dowel bar assemblies. All other transverse contraction joints shall have dowel bar assemblies.

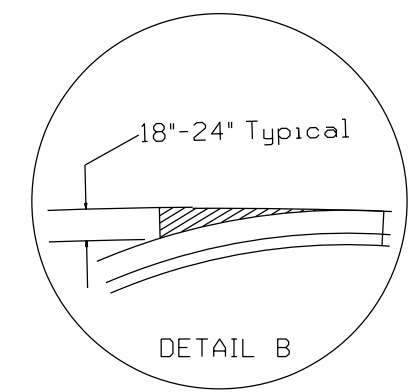
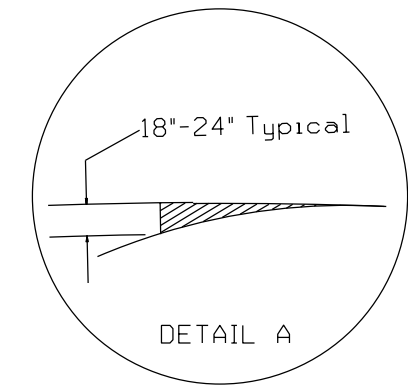

PCC PAVEMENT JOINT LAYOUT

US16B/SD79S



PROJECT	SECTION	SHEET
NH 016B(03)64	F	12

Plotting Date: 2/13/2026

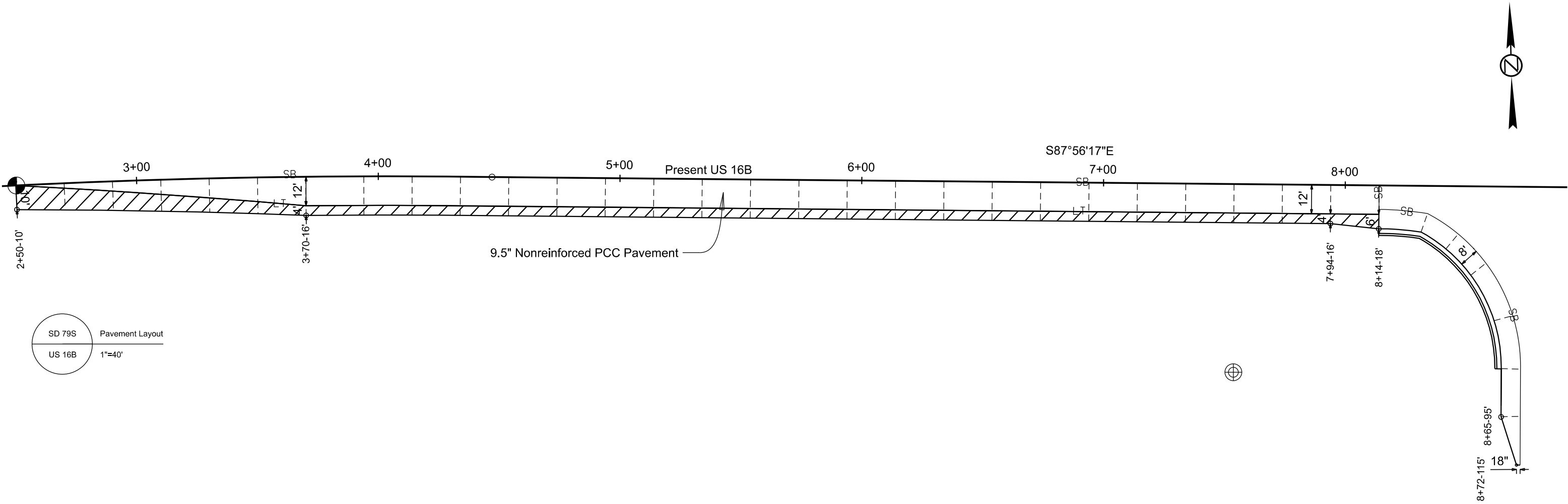

SD 79S Pavement Layout
US 16B 1"=40'

PCC PAVEMENT JOINT LAYOUT

US16B/Cambell Street

SD DOT	PROJECT	SECTION	SHEET
	NH 016B(03)64	F	13
Plotting Date: 2/13/2026			

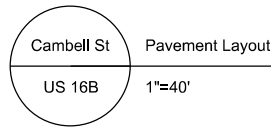
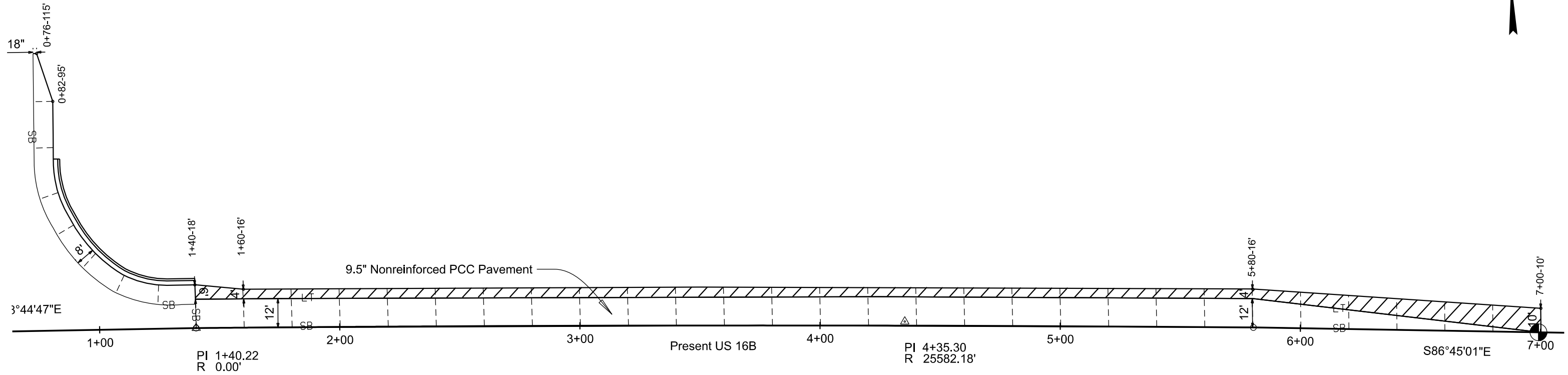

PCC PAVEMENT JOINT LAYOUT

US16B/Creek Drive



PROJECT	SECTION	SHEET
NH 016B(03)64	F	14

Plotting Date: 2/13/2026

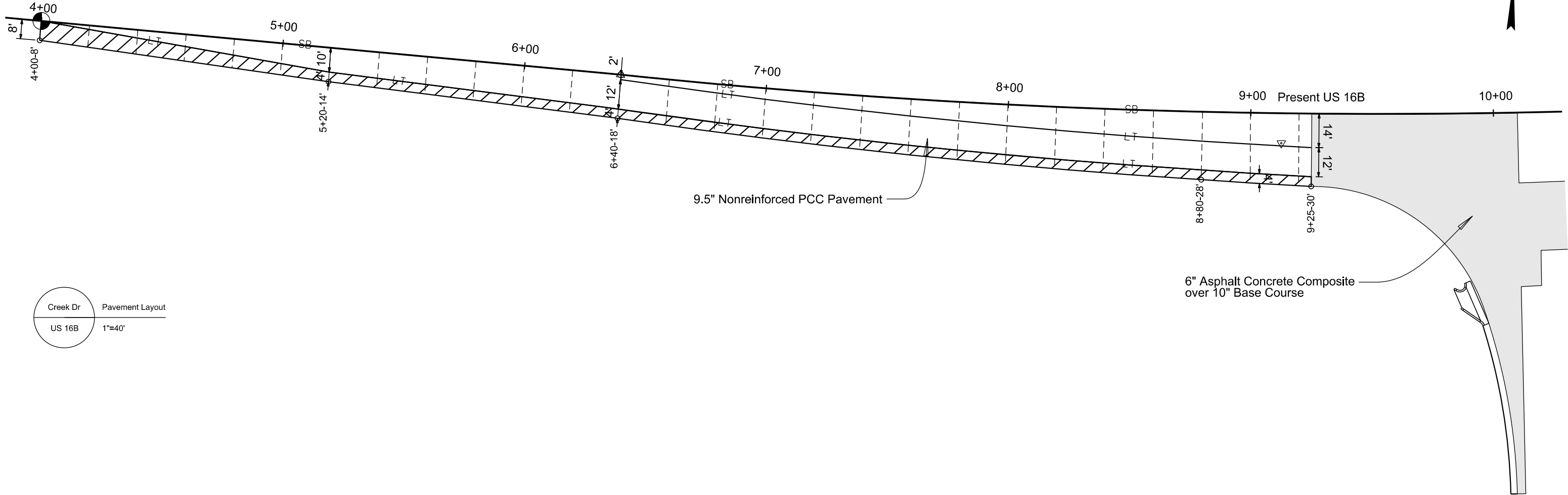

Creek Dr Pavement Layout
US 16B 1"=40'

PCC PAVEMENT JOINT LAYOUT

US16B/Homestead Street



PROJECT	SECTION	SHEET
NH 016B(03)64	F	15

Plotting Date: 2/13/2026

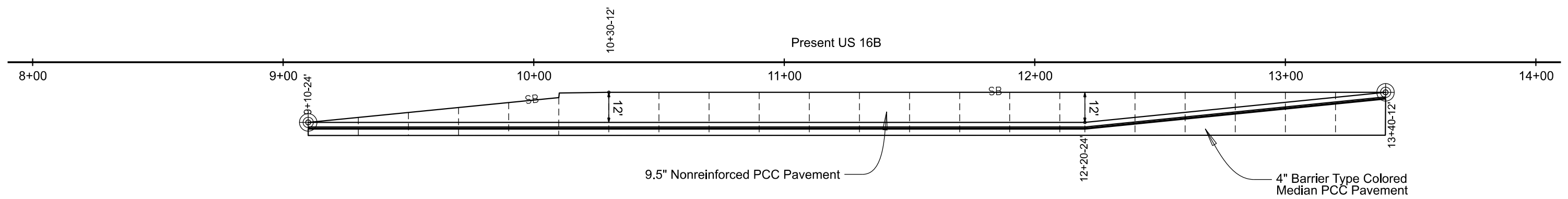
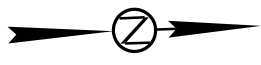

Homestead St Pavement Layout
US 16B 1"=40'

PCC PAVEMENT JOINT LAYOUT

US16B/I90 Service Road



PROJECT	SECTION	SHEET
NH 016B(03)64	F	16

Plotting Date: 2/13/2026

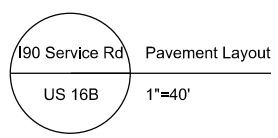
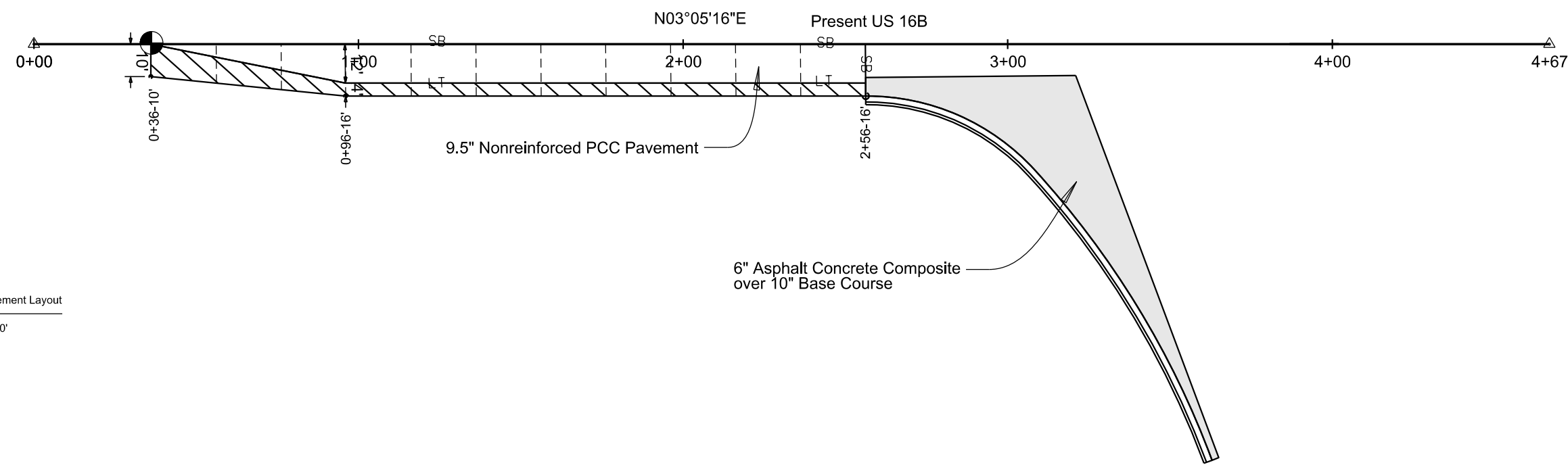
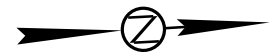

PCC PAVEMENT JOINT LAYOUT

US16B/Edwards Street



PROJECT	SECTION	SHEET
NH 016B(03)64	F	17

Plotting Date: 2/13/2026

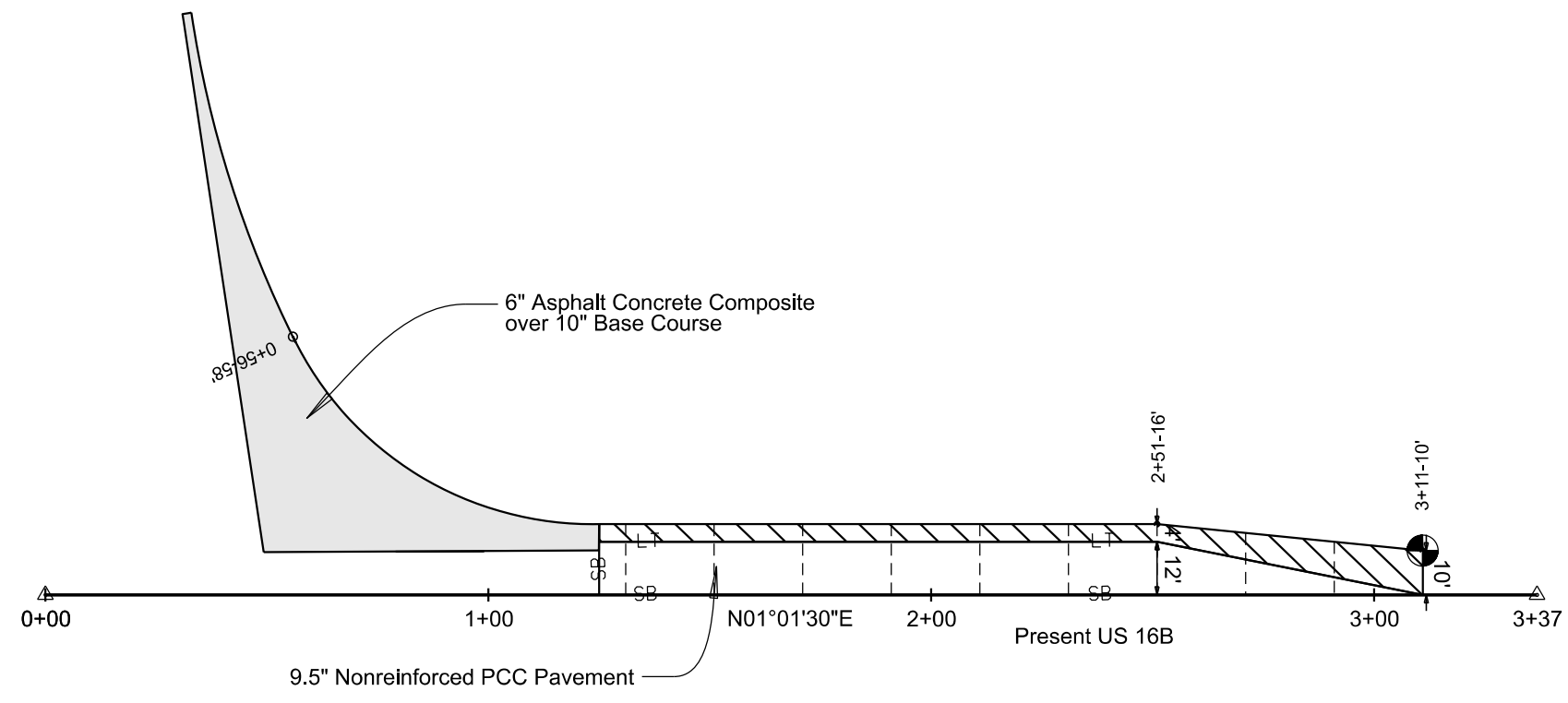
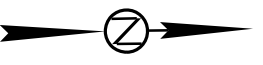

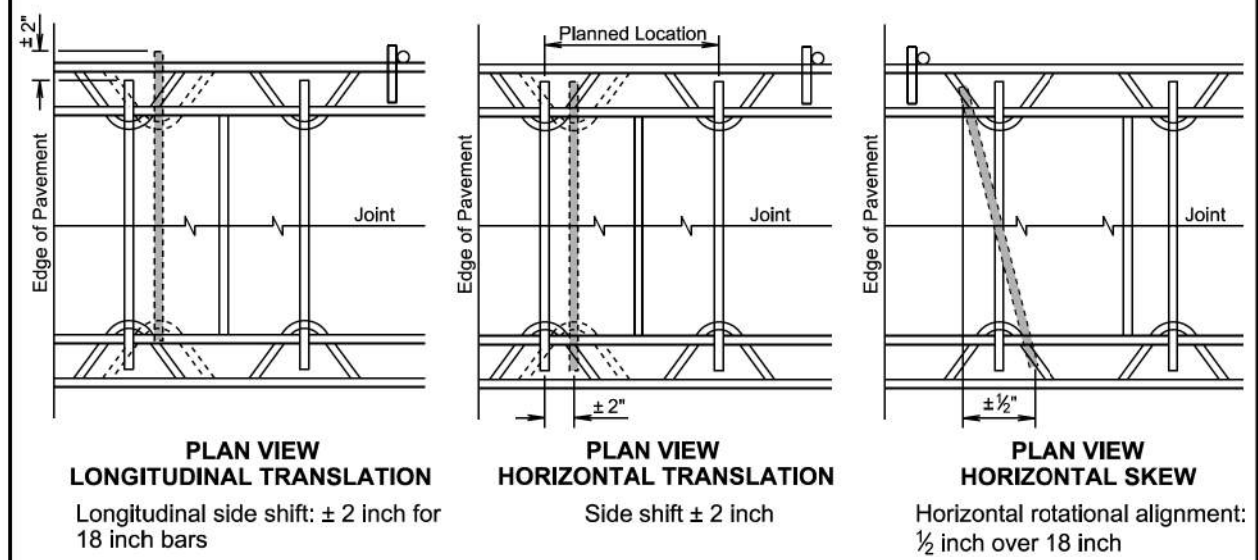
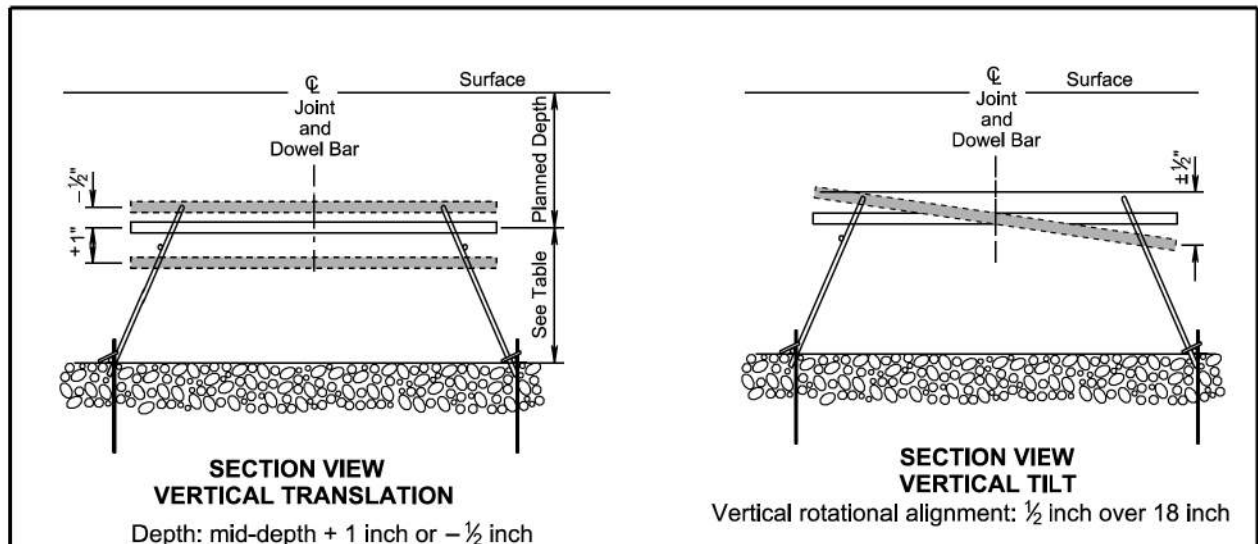

PAVEMENT THICKNESS	EPOXY COATED DOWEL BAR SIZE	HEIGHT TO CENTER
7" to 7 1/2"	1" x 18"	3.0"
8" to 10"	1 1/4" x 18"	4.0"
10 1/2" to 13"	1 1/2" x 18"	5.0"

GENERAL NOTE:
The tolerances shown above represent the maximum deviation for acceptance of dowel bar placement.

November 19, 2022

SD DOT	PCC PAVEMENT DOWEL BAR ALIGNMENT TOLERANCES	PLATE NUMBER 380.01
		Sheet 1 of 1

Published Date: 2026

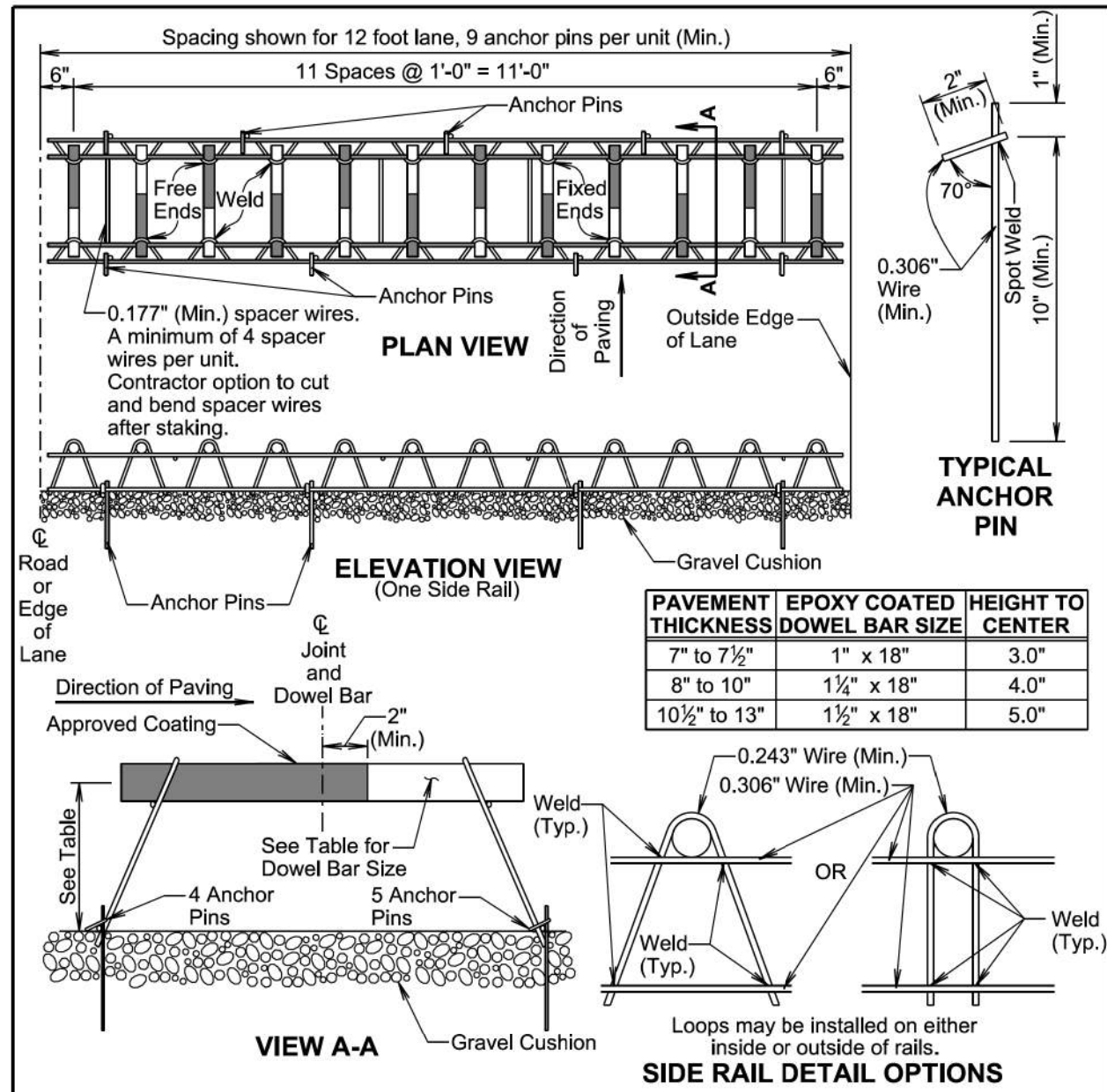

GENERAL NOTES:

Longitudinal joint tie bars will be placed a minimum of 15 inches from the transverse contraction joint.

The transverse contraction joints will be sawed perpendicular to the centerline of the roadway. The transverse sawed joint will be centered over the dowel bars.

Supporting devices as shown on this sheet, or equivalent as approved by the Engineer, will be used to maintain proper horizontal and vertical alignment of the dowel bars.

All dowel bar alignment tolerances will be as shown in the PCC Pavement Dowel Bar Alignment Tolerances standard plate.

November 19, 2022

SD DOT	PCC PAVEMENT DOWEL BAR ASSEMBLY FOR TRANSVERSE CONTRACTION JOINTS 12 Bar Assembly on Granular Base Material	PLATE NUMBER 380.04
		Sheet 1 of 1

Published Date: 2026

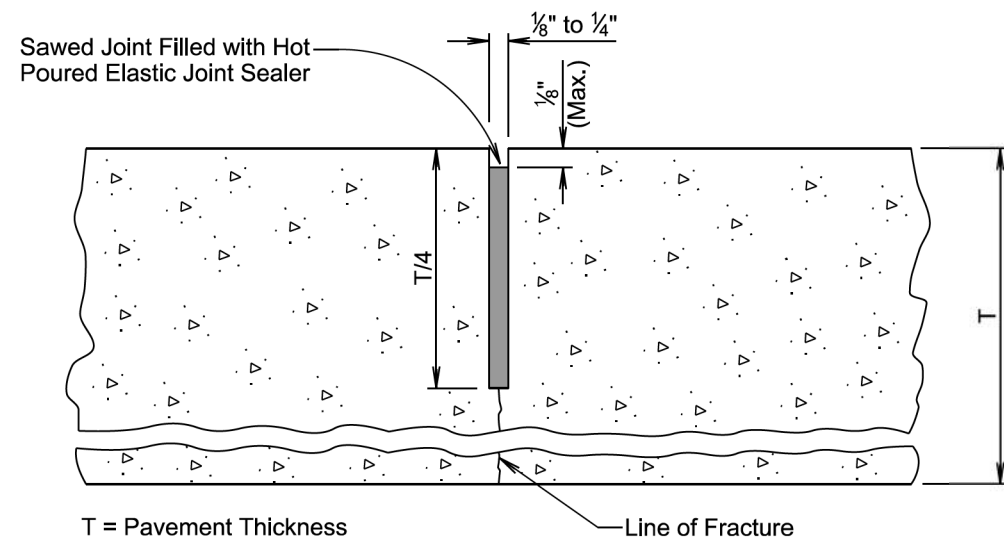

GENERAL NOTES:

If an early entrance saw cut does not develop the full transverse crack, then the saw cut to control cracking will be a minimum 1/4 of the thickness of the pavement.

All hot poured elastic joint sealer material spilled on the surface of the concrete pavement will be removed as soon as the material has cooled. The extent of removal of material will be to the satisfaction of the Engineer. All costs for removal of the spilled joint sealer material will be borne by the Contractor.

November 19, 2022

Published Date: 2026	SD DOT	PCC PAVEMENT TRANSVERSE CONTRACTION JOINT WITH OR WITHOUT DOWEL BAR ASSEMBLY	PLATE NUMBER 380.12
			Sheet 1 of 1

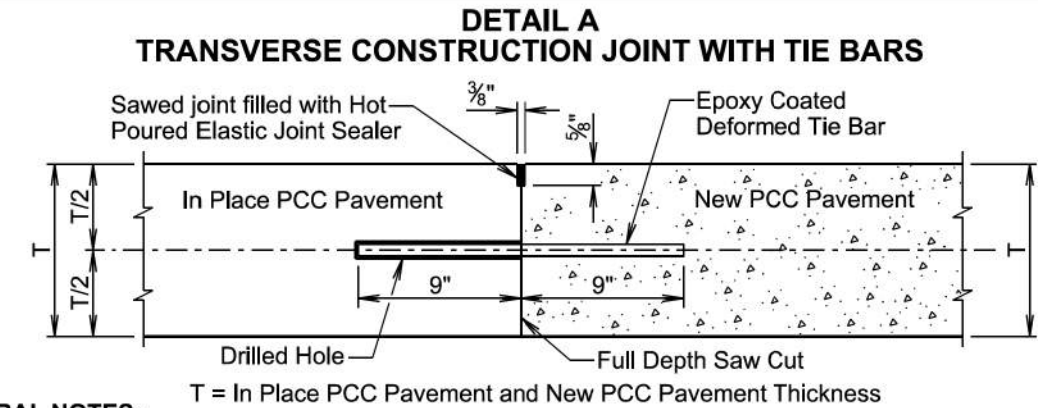

GENERAL NOTES:

The term "In Place PCC Pavement" in the above drawing indicates that the in place PCC pavement was placed on a previous project.

See sheet 2 of 2 of this standard plate to determine if Detail A will be used.

The tie bars will be embedded a minimum depth of 9 inches into the in place PCC pavement and anchored with an epoxy resin adhesive or a non-shrink grout.

No. 9 epoxy coated deformed tie bars will be used in 10 inch thickness and less PCC Pavement and No. 11 epoxy coated deformed tie bars will be used in 10.5 inch thickness and greater PCC Pavement. The tie bar spacing will be 18 inches center to center and will be a minimum of 3 inches and a maximum of 9 inches from the pavement edges.

**DETAIL B
TRANSVERSE CONSTRUCTION JOINT WITH DOWEL BARS**

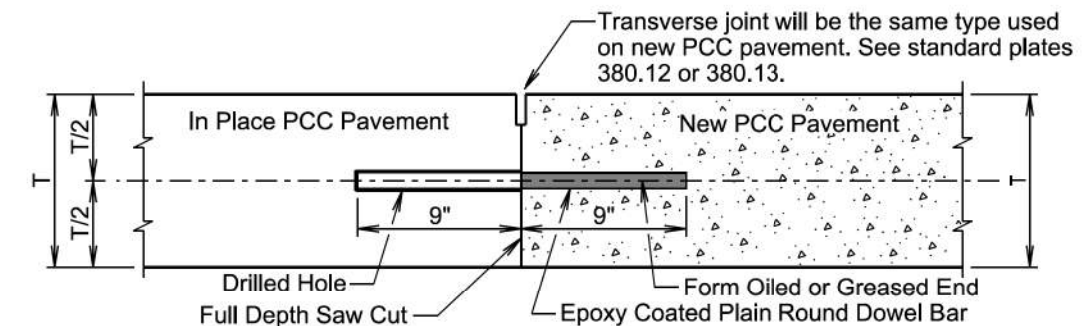

GENERAL NOTES:

The term "In Place PCC Pavement" in the above drawing indicates that the in place PCC pavement was placed on a previous project or current project.

See sheet 2 of 2 of this standard plate to determine if Detail B will be used.

The plain round dowel bars will be embedded a minimum depth of 9 inches into the in place PCC pavement and anchored with an epoxy resin adhesive or a non-shrink grout.

The epoxy coated plain round dowel bar size, number, and spacing will be the same as detailed on the corresponding dowel bar assembly standard plate (380.04, 380.05, 380.06, or 380.07). The epoxy coated plain round dowel bars will be a minimum of 3 inches and a maximum of 6 inches from the pavement edges.

January 22, 2023

Published Date: 2026	SD DOT	PCC PAVEMENT TRANSVERSE CONSTRUCTION JOINTS WITH TIE BARS OR DOWEL BARS	PLATE NUMBER 380.15
			Sheet 1 of 2

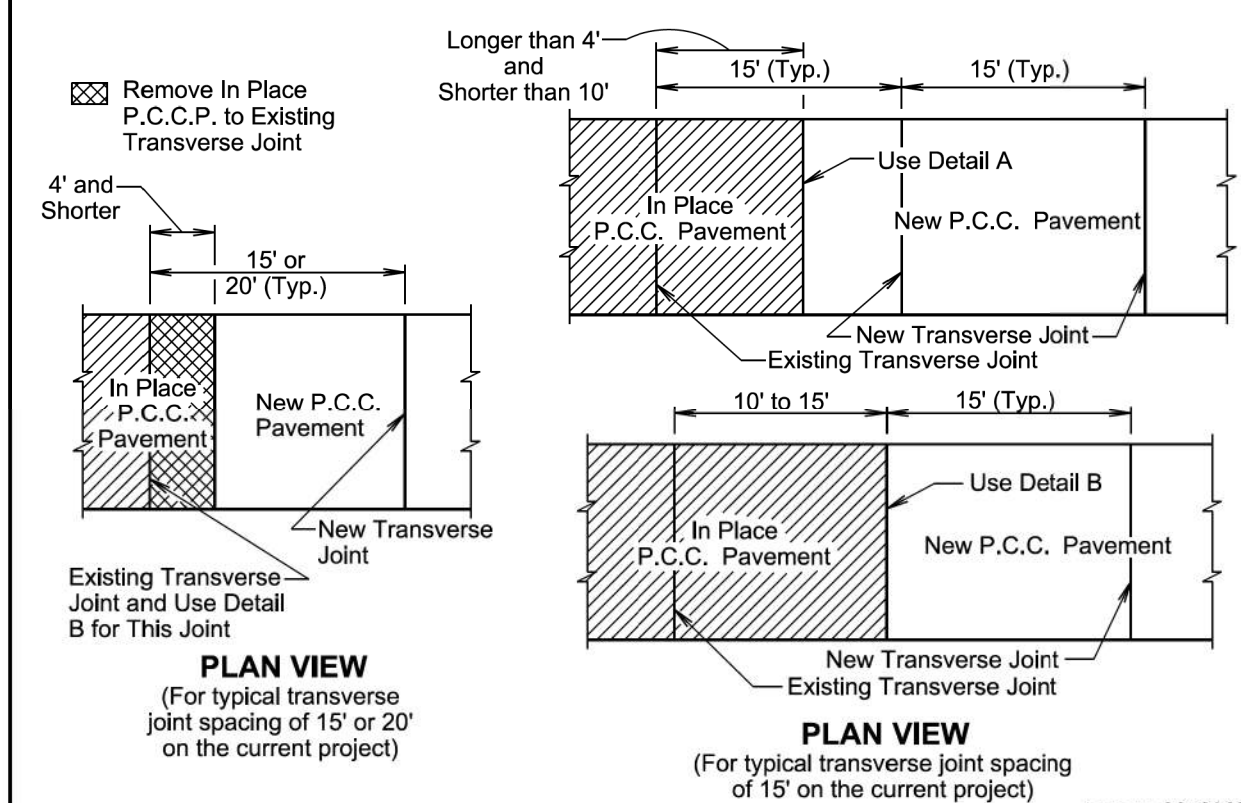
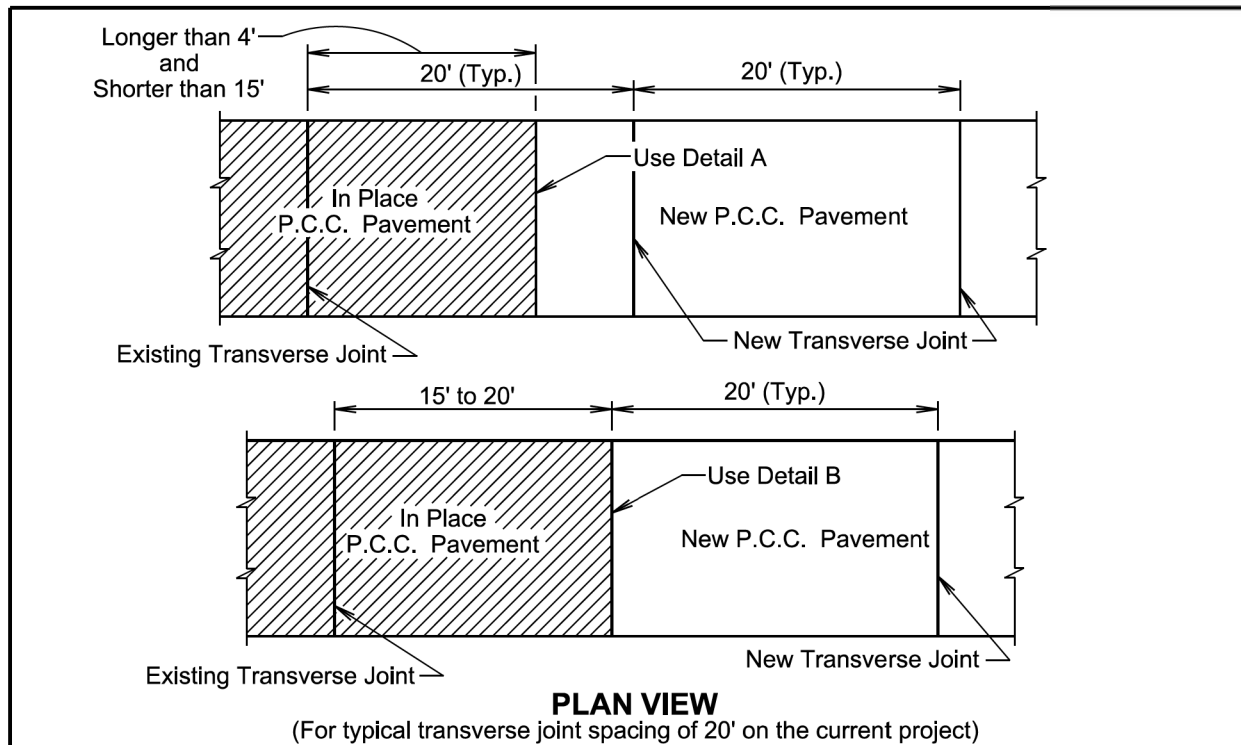

Published Date: 2026	SD DOT	PCC PAVEMENT TRANSVERSE CONSTRUCTION JOINTS WITH TIE BARS OR DOWEL BARS	PLATE NUMBER 380.15
			Sheet 2 of 2

January 22, 2023

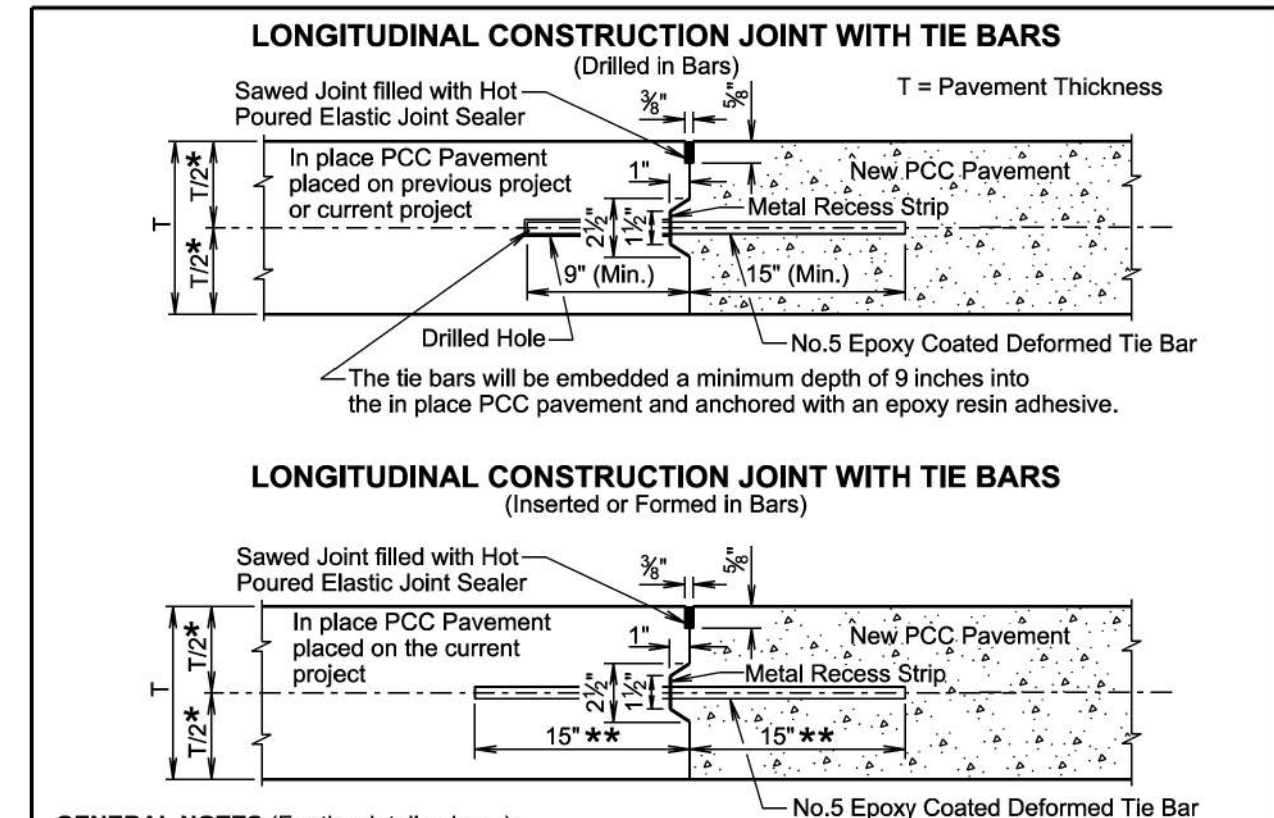

GENERAL NOTES (For the details above):

The epoxy coated deformed tie bars will be spaced in accordance with the following tables:

TIE BAR SPACING 48" MAXIMUM		TIE BAR SPACING 30" MAXIMUM	
Transverse Contraction Joint Spacing	Number of Tie Bars	Transverse Contraction Joint Spacing	Number of Tie Bars
6.5' to 10'	2	5' to 7'	2
10.5' to 14'	3	7.5' to 9.5'	3
14.5' to 18'	4	10' to 12'	4
18.5' to 22'	5	12.5' to 14.5'	5
		15' to 17'	6
		17.5' to 19.5'	7
		20' to 22'	8

The tie bars will be placed a minimum of 15 inches from transverse contraction joints.

The required number of tie bars as shown in the table will be uniformly spaced within each panel. The uniformly spaced tie bars will be spaced a maximum of 48 inches center to center for a female keyway and will be spaced a maximum of 30 inches center to center for a vertical face and male keyway. The maximum tie bar spacing will apply to tie bars within each panel.

The keyway illustrated in the above details depict a female keyway.

The keyway is optional and is not required. When concrete pavement is formed and a keyway is provided, a metal recess strip will be used. When concrete pavement is slip formed, a metal recess strip is not required.

* The vertical placement tolerance for any part of the tie bar will be $\pm T/6$.
 ** The transverse placement (side shift) tolerance will be ± 3 inches when measured perpendicular to the longitudinal joint line.

Published Date: 2026	SD DOT	PCC PAVEMENT LONGITUDINAL JOINTS WITH TIE BARS	PLATE NUMBER 380.20
			Sheet 1 of 2

November 19, 2022

SAWED LONGITUDINAL JOINT WITH TIE BARS (Poured Monolithically)

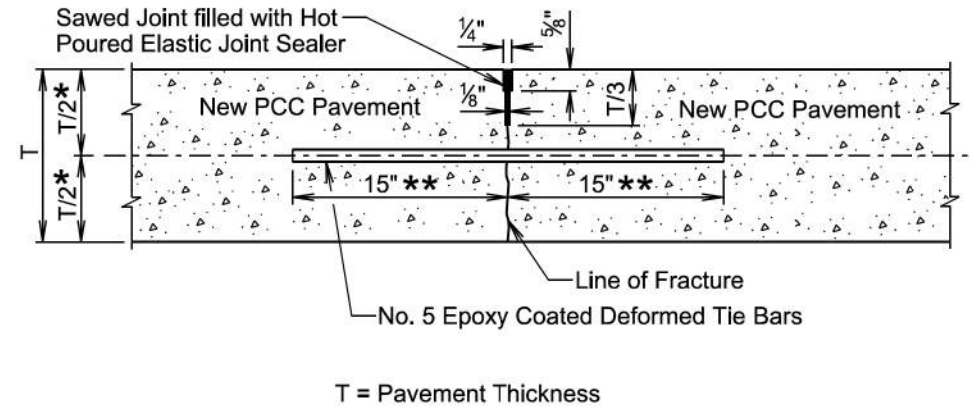

GENERAL NOTES (For the detail above):

The epoxy coated deformed tie bars will be spaced in accordance with the following table:

TIE BAR SPACING 48" MAXIMUM	
Transverse Contraction Joint Spacing	Number of Tie Bars
6.5' to 10'	2
10.5' to 14'	3
14.5' to 18'	4
18.5' to 22'	5

The tie bars will be placed a minimum of 15 inches from the transverse contraction joints.

The required number of tie bars as shown in the table will be uniformly spaced within each panel with a maximum space of 48 inches center to center. The maximum tie bar spacing will apply to tie bars within each panel.

The first saw cut to control cracking will be a minimum of 1/3 the thickness of the pavement. Additional sawing for widening the saw cut to provide the width for the installation of the hot poured elastic joint sealer is necessary.

- * The vertical placement tolerance for any part of the tie bar will be $\pm T/6$.
- ** The transverse placement (side shift) tolerance will be ± 3 inches when measured perpendicular to the longitudinal joint line.

November 19, 2022

Published Date: 2026

SD
DOT

PCC PAVEMENT LONGITUDINAL
JOINTS WITH TIE BARS

PLATE NUMBER
380.20

Sheet 2 of 2

LONGITUDINAL CONSTRUCTION JOINT WITH TIE BARS (Individually Formed)

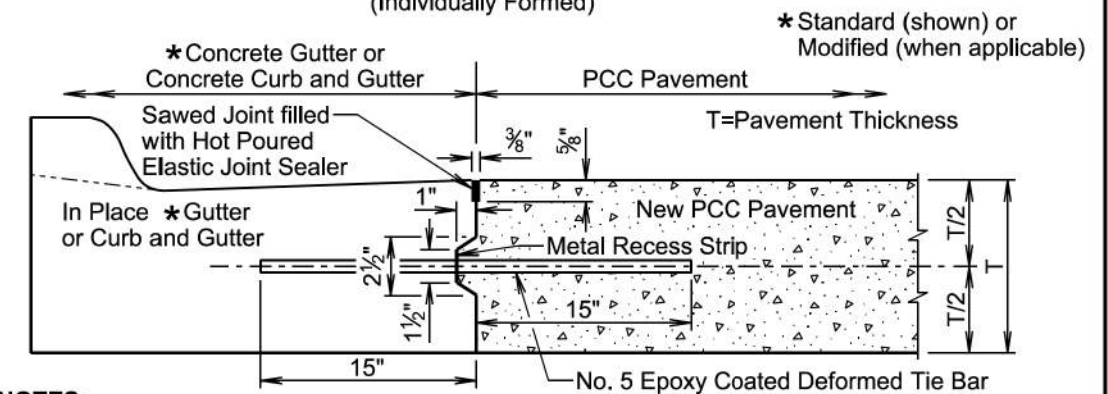

GENERAL NOTES:

No. 5 epoxy coated deformed tie bars will be spaced 48 inches center to center. The tie bars will be placed a minimum of 15 inches from existing transverse contraction joints. The keyway shown above is a female keyway.

The keyway is optional and is not required. When concrete pavement is formed and a keyway is provided, a metal recess strip will be used. When concrete pavement is slip formed, a metal recess strip is not required.

The transverse contraction joints in the concrete gutter or concrete curb and gutter will be placed at each mainline PCC pavement transverse contraction joint. The transverse contraction joints in the concrete gutter or the concrete curb and gutter will be 1 1/2 inches deep if formed in fresh concrete using a suitable grooving tool. If a saw is used to cut the transverse contraction joints, then the depth of the joint will be at least 1/4 the thickness of the concrete gutter or concrete curb and gutter.

Standard curb and gutter may not be placed monolithically with PCC pavement if the mainline lane width is greater than 12 feet.

The term "In Place *Gutter or Curb and Gutter" in the above drawing indicates that the in place *concrete gutter and concrete curb and gutter was placed on the current project.

POURED MONOLITHICALLY (Standard Concrete Curb and Gutter)

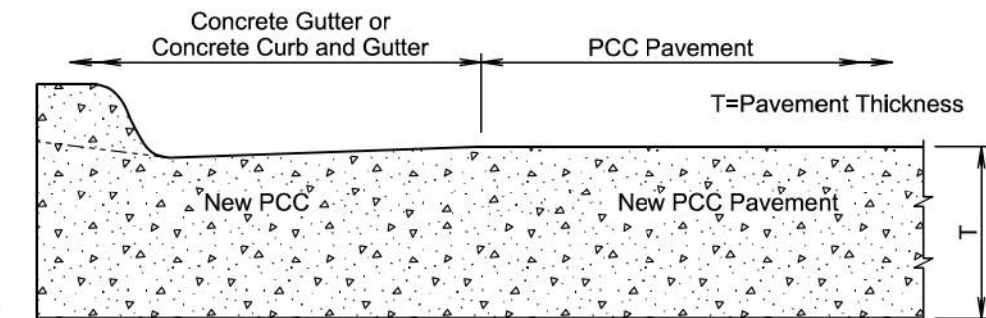

GENERAL NOTES:

The mainline curb and gutter may be placed monolithically with the PCC pavement if the mainline lane width is less than or equal to 12 feet. If this method of construction is used, the tie bars and the sawed joint between the curb and gutter and the PCC pavement will be eliminated.

The gutter or curb and gutter will be sawed transversely at each mainline transverse contraction joint. The transverse contraction joints in the gutter or curb and gutter will be sawed and sealed same as the transverse contraction joints in the PCC pavement.

The slope of the gutter will be the slope designated for the type of gutter or curb and gutter to be constructed. The bottom slope of the gutter or curb and gutter will be constructed at the same slope as the mainline concrete pavement.

March 31, 2024

Published Date: 2026

SD
DOT

PCC PAVEMENT LONGITUDINAL CONSTRUCTION
JOINTS WITH CONCRETE GUTTER OR
CONCRETE CURB AND GUTTER

PLATE NUMBER
380.21

Sheet 1 of 2

POURED MONOLITHICALLY (Concrete Curb and Modified Gutter)

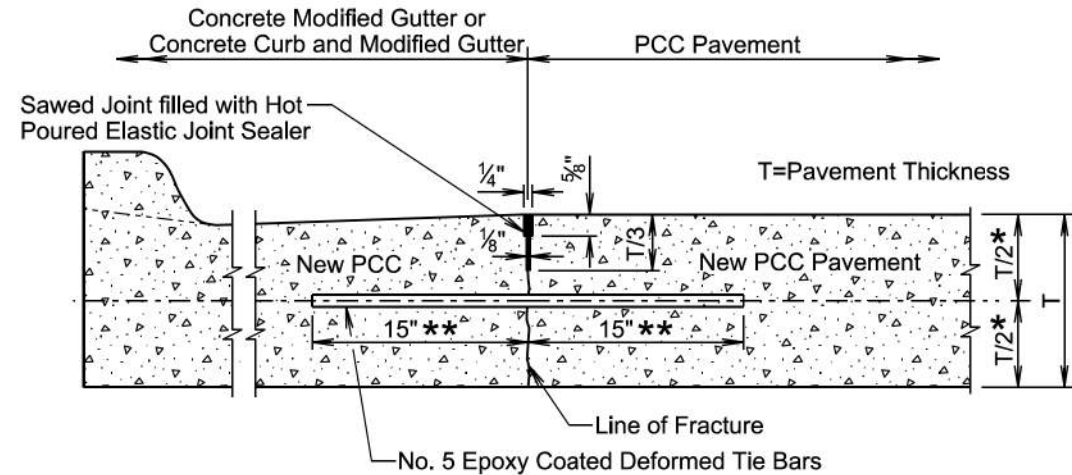

GENERAL NOTES:

- No. 5 epoxy coated deformed tie bars will be spaced 48 inches center to center.
- The tie bars will be placed a minimum of 15 inches from existing transverse contraction joints.
- The mainline curb and modified gutter may be placed monolithically with the PCC pavement if the mainline lane width is less than or equal to 14 feet.
- The first saw cut to control cracking will be a minimum of 1/3 the thickness of the pavement. Additional sawing for widening the saw cut to provide the width for the installation of the hot poured elastic joint sealer is necessary.
- The gutter or curb and gutter will be sawed transversely at each mainline transverse contraction joint. The transverse contraction joints in the gutter or curb and gutter will be sawed and sealed same as the transverse contraction joints in the PCC pavement.
- The slope of the gutter will be the slope designated for the type of gutter or curb and gutter to be constructed. The bottom slope of the gutter or curb and gutter will be constructed at the same slope as the mainline concrete pavement.

* The vertical placement tolerance for any part of the tie bar will be $\pm T/6$.
 ** The transverse placement (side shift) tolerance will be ± 3 inches when measured perpendicular to the longitudinal joint line.

March 31, 2024

Published Date: 2026	SD DOT	PCC PAVEMENT LONGITUDINAL CONSTRUCTION JOINTS WITH CONCRETE GUTTER OR CONCRETE CURB AND GUTTER	PLATE NUMBER
			380.21
			Sheet 2 of 2

LONGITUDINAL CONSTRUCTION JOINT WITHOUT TIE BARS

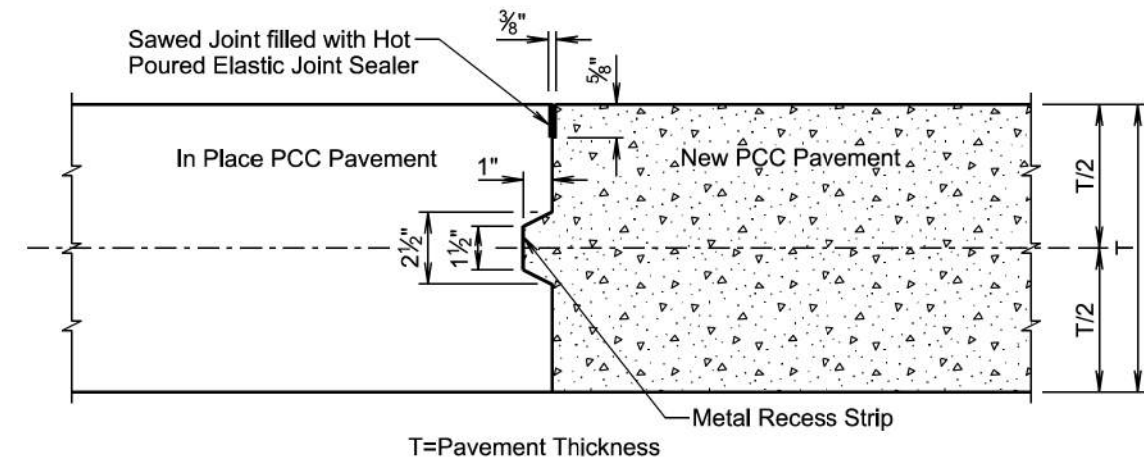

GENERAL NOTES:

- When concrete pavement is formed and a keyway is provided, a metal recess strip will be used. When concrete pavement is slip formed, a metal recess strip is not required.
- The term "In Place PCC Pavement" in the above drawing indicates that the in place PCC pavement was placed on the current project.

LONGITUDINAL CONSTRUCTION JOINT WITHOUT TIE BARS

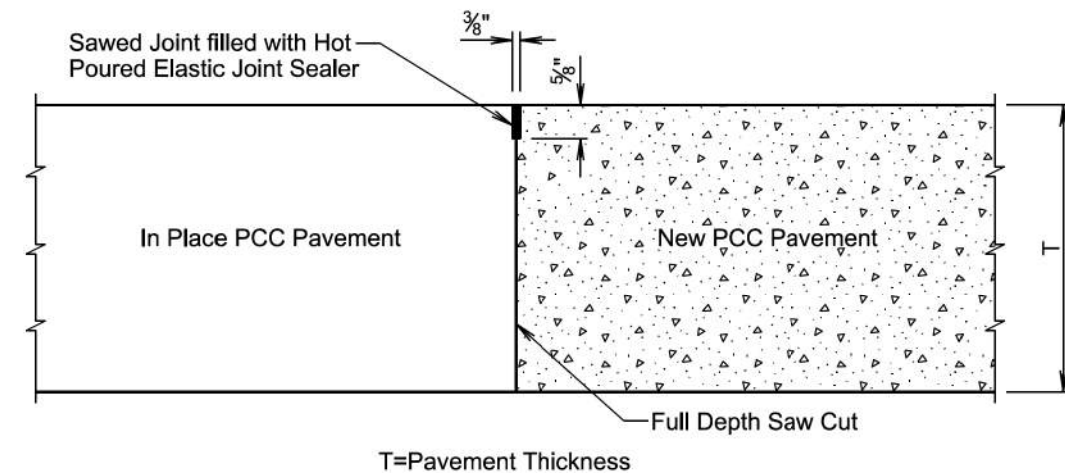

GENERAL NOTE:

- The term "In Place PCC Pavement" in the above drawing indicates that the in place PCC pavement was placed on a previous project.

November 19, 2022

Published Date: 2026	SD DOT	PCC PAVEMENT LONGITUDINAL JOINTS WITHOUT TIE BARS	PLATE NUMBER
			380.22
			Sheet 1 of 2

SAWED LONGITUDINAL JOINT WITHOUT TIE BARS

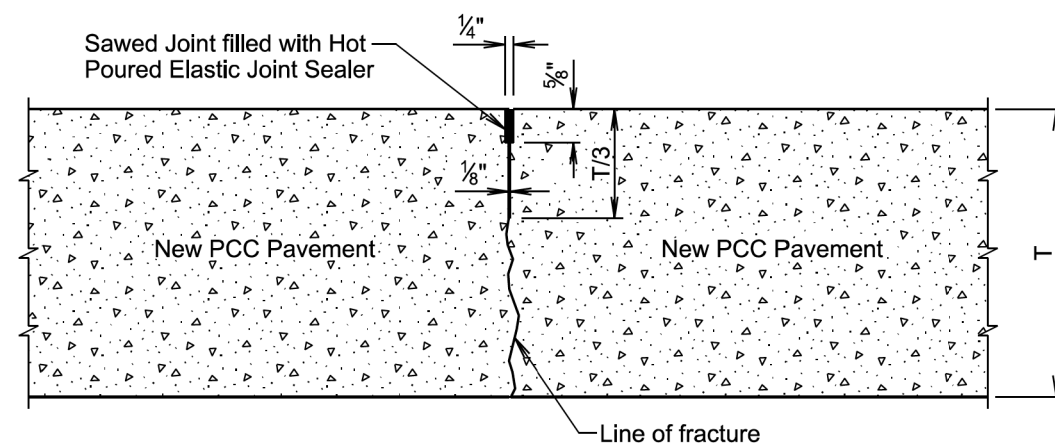

T=Pavement Thickness

GENERAL NOTE:

The first saw cut to control cracking will be a minimum of $\frac{1}{3}$ the thickness of the pavement. Additional sawing for widening the saw cut to provide the width for the installation of the hot poured elastic joint sealer will be necessary.

November 19, 2022

Published Date: 2026

SD
DOT

**PCC PAVEMENT LONGITUDINAL
JOINTS WITHOUT TIE BARS**

PLATE NUMBER
380.22

Sheet 2 of 2