

# SECTION S: PERMANENT SIGNING PLANS

SD DOT	PROJECT	SECTION	SHEET
	NH 016B(03)64	S	1/26

Plotting Date: 1/26/2026

## INDEX OF SHEETS

S1	General Layout with Index
S2-S8	Estimate With General Notes & Tables
S9-S14	Signing Layouts
S15-S16	Sign Designs
S17-S21	Special Details
S22-S26	Standard Plates

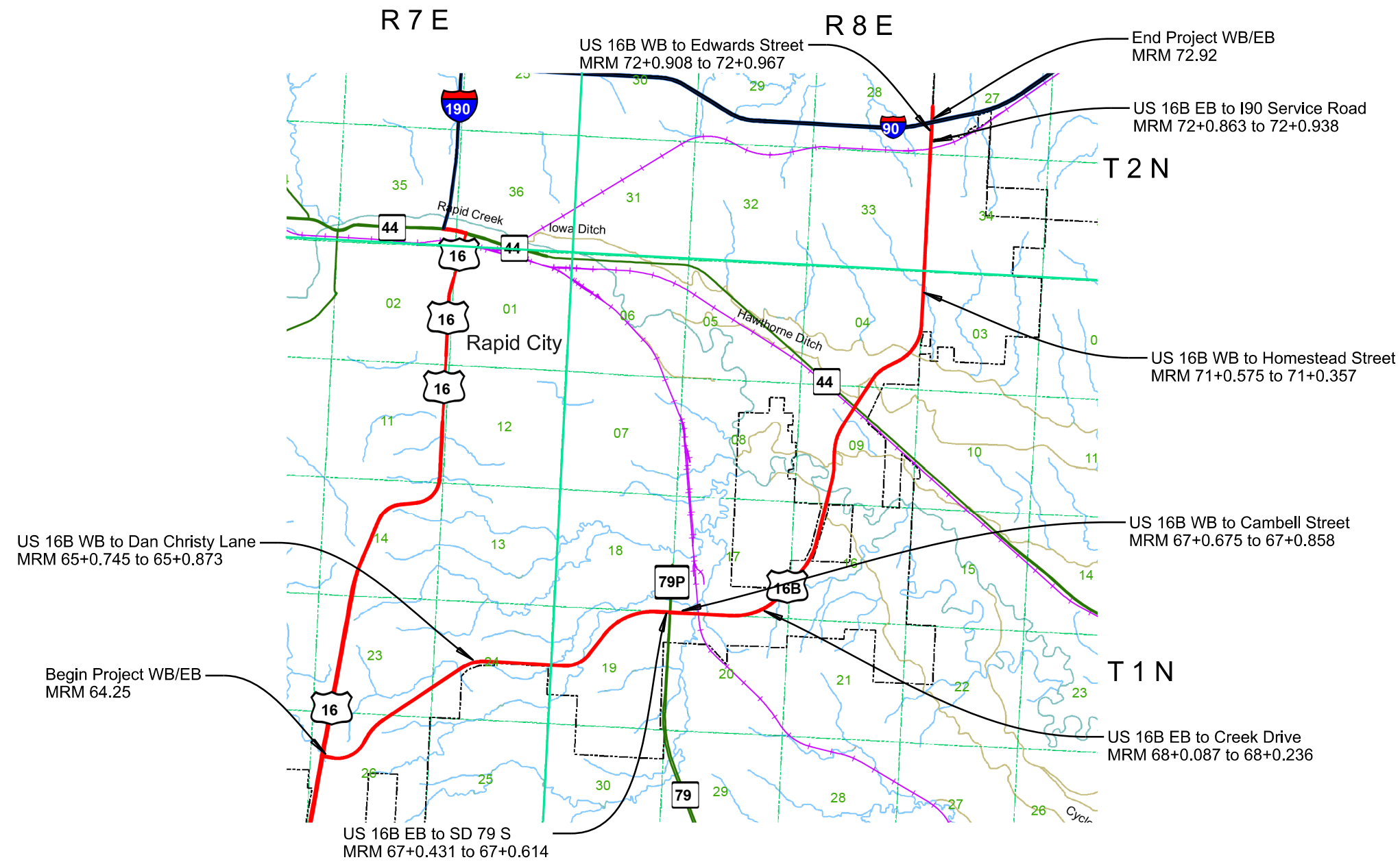

## SECTION S – ESTIMATE OF QUANTITIES

BID ITEM NUMBER	ITEM	QUANTITY	UNIT
110E0130	Remove Traffic Sign	16	Each
110E7150	Remove Sign for Reset	3	Each
632E1340	2.5"x2.5" Perforated Tube Post	110.3	Ft
632E1375	4.0"x4.0" Tubular Post	179.6	Ft
632E2024	4"x8" White Delineator with 1.12 Lb/Ft Post	37	Each
632E2028	4" Tubular White Delineator with 1.12 Lb/Ft Post	19	Each
632E3203	Flat Aluminum Sign, Nonremovable Copy High Intensity	312.5	SqFt
632E3205	Flat Aluminum Sign, Nonremovable Copy Super/Very High Intensity	54.0	SqFt
632E3500	Reset Sign	3	Each
632E6100	Slip Base Assembly for 4.0"x4.0" Tubular Post	12	Each
632E6105	Multi-Directional Hinge Assembly for 4.0"x4.0" Tubular Post	10	Each
632E6110	4.0"x4.0" Tubular Post Closure Cap	12	Each

### GENERAL PERMANENT SIGNING

New sign installations will be staked in the field by the Contractor and checked by the Engineer. The Contractor will give the Engineer a minimum of one week to check staked locations prior to signpost installation. Lateral offset of signs will be as shown in the plans or as directed by the Engineer.

The Contractor will be responsible for contacting South Dakota One Call to locate the utilities at the staked sign installation locations.

When signs are mounted in an assembly, they will be 1-2 inches apart vertically and horizontally.

The height of the post must not exceed the minimum height needed by more than 0.5 feet. Any portion that extends above the sign will be cut off. No separate payment will be made for cutting the post or for that length cut off.

Aluminum U-Channel stiffeners will be used on all signs 36 inches or greater in width and will conform to ASTM B221 Alloy 6063-T6 or 6061-T6. The U-Channel will be 2 inches in width and free of holes. The U-Channel stiffeners will also be used to connect various signs together so that an entire sign assembly can be erected on a single installation. Stiffeners may be fastened to signs by use of 1/4-inch diameter drive rivets.

Aluminum sign brace will be used on all signs attaching to 4" tube posts. The sign brace will be 2 inches in width and free of holes. The sign brace will also be used to connect various signs together so that an entire sign assembly can be connected to 4" tube posts on a single installation. Sign braces may be fastened to signs by use of 3/8-inch diameter drive rivets. Sign braces will be capable of using T-head bolts for connection to 4" tube posts.

The Contractor will use 3/8-inch diameter rust proof machine sign bolts, flat metal washers, neoprene washers (against the sign sheeting), lock washers, and nuts to fasten the sign to the channel aluminum and posts. A minimum of two bolts will extend through each post.

Prior to ordering signs, the Contractor will verify dimensions, background, border, and legend of the signs.

Prior to use, the Contractor will provide documentation for the sign support devices showing they meet the applicable NCHRP 350 or MASH requirements.

### REMOVE TRAFFIC SIGN

Existing signs that are shown as being removed in the Permanent Signing Table will become the property of the Contractor. Existing signposts and bases will be removed in their entirety. All existing signs, posts, and/or hardware removed will not be reused. Holes remaining from the removal of wood posts will be backfilled and compacted with material placed in layers not to exceed 6 inches in depth.

All costs associated with the removal of existing signs, posts, hardware, and backfilled holes will be incidental to the contract unit price per each for "Remove Traffic Sign". Quantities will be per assembly at the contract unit price per each.

### REMOVE SIGN FOR RESET AND RESET SIGN

Signs that are scheduled for reset will be dismantled and reassembled to the extent needed by the Contractor to properly reset the sign. Signs will be handled with care so that the existing signs, posts, and bases are not damaged during the relocation process. The Contractor will replace and pay for any reset signs damaged in their care. The Contractor will remove and dispose of any existing posts for all reset signs that require use of new posts as shown in the Table of Permanent Signing.

All costs for removing, dismantling, and disposing of any existing posts will be incidental to the contract unit price per each for "Remove Sign for Reset". All costs for resetting the existing signs will be incidental to the contract unit price per each for "Reset Sign". All quantities for Remove Sign for Reset and Reset Sign will be per assembly at the contract unit price per each.

### NEW PERMANENT SIGNING

All signs will be manufactured in accordance with the sheeting manufacturer's recommendations utilizing a matched component system, including inks, electronic cuttable films, and protective overlay films.

All Flat Aluminum Signs, Nonremovable Copy High Intensity will have sheeting in conformance with the requirements of ASTM D4956 Type IV. All Flat Aluminum Signs, Nonremovable Copy Super/Very High Intensity will have sheeting in conformance with the requirements of ASTM D4956 Type XI.

All costs associated with furnishing and installing the new permanent signs, and with furnishing and installing stiffeners and hardware will be incidental to the contract unit price per square foot for "Flat Aluminum Sign, Nonremovable Copy High Intensity" or "Flat Aluminum Sign, Nonremovable Copy Super/Very High Intensity".

### SQUARE TUBE ANCHOR SLEEVE

The Contractor will furnish and install new 2.5" x 2.5" x 18", 12 Gauge square tube anchor sleeve or equivalent components as approved by the Engineer for 2.0" x 2.0" perforated tube posts. A 2.25" x 2.25" x 4", 12 Gauge perforated tube post will be used as the anchor post for installation with the square tube anchor sleeve.

### SQUARE TUBE POST SLEEVE

All 2.5" x 2.5", 10 Gauge perforated tube post will be sleeved with a 2-3/16" x 2-3/16" x 4", 10 Gauge perforated tube post.

### WINGED SLIP BASE ANCHOR

The Contractor will furnish and install new winged slip base anchors for 2.5" x 2.5" perforated tube posts as required in the Permanent Signing Table. Winged slip base anchors will be installed using the direct drive method. Winged slip base anchors will consist of a slip base (upper), a 48-inch long winged anchor (lower), and a hardware kit.

### 4" SLIP BASE ANCHOR

The Contractor will furnish and install new 13" MASSH-400 Slip Base for 4" x 4" tube posts as required in the Permanent Signing Table. Slip Base anchors will be installed in 18" diameter by 48" deep concrete footing. Reinforcing steel will not be required in the concrete footing for 13" MASSH-400 Slip Base for 4" x 4" tube posts.

All costs for furnishing and installing the 13" MASSH-400 Slip Base for 4" x 4" tube posts will be included in the price for "Slip Base Assembly for 4.0"x4.0" Tubular Post".

### TUBULAR POST CLOSURE CAP

Tubular Post Closure Caps will be of a type that is compatible with 4.0"x4.0" Tubular Post. Tubular Post Closure Caps will be capable of keeping water and debris out of the 4.0"x4.0" Tubular Post and will be securely fastened to the post.

### POLE MOUNTED SIGNS

Signs that are mounted on luminaire poles will be attached with high strength stainless steel bands or galvanized pole clamps. Signs will be attached as recommended by the manufacturer. All sign mounting hardware will be stainless steel or galvanized steel.

Pole mounted signs will be mounted a minimum of 7 ft above the ground. Mounting heights are measured to the bottom of the signs.

All costs for pole sign mounting hardware will be incidental to the contract unit price per square foot for "Nonremovable Copy Super/Very High Intensity".

## **DIGITALLY PRINTED SIGNS**

Digitally printed signs will be allowed on this project. If the Contractor elects to provide digitally printed signs, such signs will adhere to the following specifications.

### **PROTECTIVE OVERLAY FILM**

Permanent traffic signs printed with digital ink systems will be fabricated with a full sign protective overlay film designed to provide a smooth surface needed for retroreflectivity, and to protect the sign from fading and UV degradation. The overlamine will comply with the retroreflective sheeting manufacturer's recommendations to ensure proper adhesion and transparency and will also meet the reflective film durability as identified in Table 1.

Table 1: Retroreflective Film Minimum Durability Requirements

ASTM D4956 Type	Full Sign Replacement Term (years)	Sheeting Replacement Term (years)
I	0	7
III	7	10
IV	7	10
VIII	7	10
IX	7	12
XI	7	12

### **FABRICATION**

Retroreflective sheeting will be applied to a properly cleaned and prepared aluminum sign blank in accordance with the retroreflective sheeting manufacturer's recommendations. Sign legend will be applied using digital print technologies and systems in accordance with the retroreflective sheeting manufacturer's recommendations and the requirements of these plans.

Finished signs will be free of ragged edges and must be supplied clean and free of scratches, grease, oil, lubricants or other contaminants. Minor blemishes (dirt speck, dust, etc.) may settle on the fresh ink surface or become entrapped between the sheeting surface and transparent overlay film due to static charge within the sign shop environment. Any blemish must be minor and not interfere with the communication of the sign message to the motorist. The blemish must not be visible to the naked eye when viewed from 30 feet or greater.

After application of the retroreflective sheeting, sign blanks will be stacked and packaged face to face, back to back, and protected in accordance with the sheeting manufacturer's recommendations. Finished signs will be securely packaged to prevent damage during transit or storage according to the sheeting manufacturer's recommendations.

### **TRAFFIC SIGN PERFORMANCE WARRANTY PROVISIONS**

Based on the ASTM Type of sheeting specified, traffic control signs will be warranted for the duration shown in Table 1. Full product terms and conditions are as established by each sheeting manufacturer and may contain certain limitations based on sheeting and ink colors, and geographic exposure of the sign. A copy of the warranty document with complete details of terms and conditions will be supplied if requested by the Engineer.

### **CERTIFIED DIGITAL SIGN FABRICATOR**

Sign fabricators using digital imaging methods to produce regulated traffic signs must be certified by the reflective sheeting manufacturer whose materials are used to produce the delivered signs.

### **DATE TAGGING SIGNS WITH PERTINENT INFORMATION**

All digitally printed signs are required to be date-tagged with the following 2 components:

1. Date tags on the back of signs  
Tags will have the following information and be fabricated with material and printing system that are as durable as the warranted sign.
  - Name of Sign Fabricator
  - Date the sign was fabricated (month and year)
  - Process that was used for sign fabrication (digitally printed)
  - Supplier of sheeting that was used for fabricating the sign.
2. Border date  
The month and year (mm/yyyy) of sign fabrication will be printed in the border of the sign in 3/8" sans serif font. Border date will be printed with the same warranted printed system as the sign face. The date should be printed in the locations indicated below.

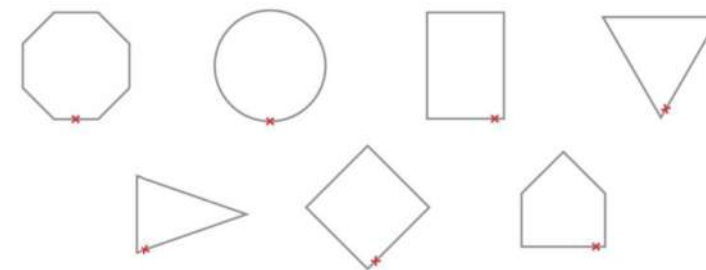

### **CONCRETE FOOTING FOR SLIP BASE ANCHOR**

The Contractor will furnish and install 18" diameter by 48" deep concrete footing for each 13" MASSH-400 Slip Base for 4" x 4" tube post. Concrete for these footings will meet the requirements of Concrete for Incidental Construction – Class M (M6 Concrete).

The location of the 4 stop signs at int intersection of Hwy 212 and Hwy 85 are located on concrete islands. The Contractor will be required to "core" through the existing concrete to install the 18" diameter footing. Any concrete damaged by the "coring" process will be replaced by the Contractor at no additional cost to the State.

All costs for equipment, materials, and labor to install the concrete footings will be incidental to the unit price for "Slip Base Assembly for 4.0"x4.0" Tubular Post".

### **NEW CONCRETE FOOTING**

New concrete footings will be installed a minimum of 10 ft from old footings greater than 4 ft in depth that have been completely removed, or 5 ft from old footings 4 ft or less in depth that have been completely removed or from footings that have been broken down approximately 1 ft below ground level. The Contractor may adjust new footing locations to comply with the indicated minimum distances if lateral plan offset is maintained, with the approval of the Engineer.

Contractor will ensure the footings are constructed in accordance with the plan sheets, and the finished ground line at all footings are per the details shown on the plan sheets.

Disturbed areas outside the grading project limits will be seeded to the satisfaction of the Engineer. The cost of seeding outside the grading project limits will be incidental to the contract unit price per foot for the various Concrete Footing items.



PCN 08RT - PERMANENT SIGNING US HWY 16B & DAN CHRISTY LANE

HWY	STA & OFFSET Existing	STA & OFFSET New	SIGN				POST										SIGN DESCRIPTION	WORK TO BE DONE	LF of 2.5"	LF of 4.0"	FLAT ALUMINUM SIGN		REMOVE SIGN	REMOVE SIGN FOR RESET & RESET SIGN					
			Side of Road	Width (in)	Height (in)	Direction Facing	Location	New Sign	Sign Type	Square Footage	Sheeting Type	New Post	Length Post #1 (ft)	Offset to center of Post #1 (ft)	Length Post #2 (ft)	Offset to center of Post #2 (ft)					Size (in)	# of Posts			Shear Slip Base	SQFT IV	SQFT XI		
016 WB	1+37 21' L	1+36 84' L	Left			East	NO				NO										D3-1: Dan Christy Ln	Remove existing signs and post for reset. Reset existing on on existing post in new location.							
						West	NO			D3-1: Dan Christy Ln																			
						North	NO			D3-1: Catron Blvd																			
						South	NO			D3-1: Catron Blvd																			
016 WB	1+69 25' L	1+96 46' L	Left	36	36	West	ROW	YES	FLAT ALUM	9.0	XI	YES	12.6	46.0					2.5	1	YES	R5-1: DO NOT ENTER	Remove existing sign and posts. Install new sign on new post.	12.6			9.0	1	
<b>DAN CHRISTY LANE TOTALS:</b>																<b>12.6</b>	<b>0.0</b>	<b>0.0</b>	<b>9.0</b>	<b>1</b>	<b>1</b>								



Plotting Date: 1/28/2026

**PCN 08RT - PERMANENT SIGNING US HWY 16B & SD HWY 79/CAMBELL**

HWY	STA & OFFSET Existing	STA & OFFSET New	Side of Road	SIGN			POST										SIGN DESCRIPTION	WORK TO BE DONE	LF of 2.5"	LF of 4.0"	FLAT ALUMINUM SIGN		REMOVE SIGN	REMOVE SIGN FOR RESET & RESET SIGN			
				Width (in)	Height (in)	Direction Facing	Location	New Sign	Sign Type	Square Footage	Sheeting Type	New Post	Length Post #1 (ft)	Offset to center of Post #1 (ft)	Length Post #2 (ft)	Offset to center of Post #2 (ft)					Size (in)	# of Posts			Shear Slip Base	SQFT IV	SQFT XI
016 EB	2+35 28' R	1+97 26' R	Right	114	36	West	ROW	YES	FLAT ALUM	28.5	IV	YES	12.9	26.0	13.8	31.7	4.0	2	YES	D1-2: Rapid City left arrow, Hot Springs right arrow	Remove existing signs and posts. Install new sign on new posts.		26.7	28.5		1	
016 EB	3+26 24' R	3+26 30' R	Right			West	ROW	NO		0.0		YES	14.5	30.0	14.9	32.4	2.5	2	YES	W3-4: PREPARE TO STOP	Remove existing signs and posts for reset. Reset existing signs on existing posts. Flashing beacon will be removed and reset with the sign assembly.	29.4				1	
						West		NO		0.0																	
016 EB	5+52 31' R	5+63 32' R	Right			North	ROW	YES	FLAT ALUM	4.5	IV	YES	18.1	32.0	17.3	37.7	4.0	2	YES	M4-4: TRUCK ROUTE MARKER - US	Remove existing signs and posts. Install new signs on new posts.	35.4				1	
						North		YES	FLAT ALUM	4.5	IV									M3-2: DIRECTIONAL MARKER - EAST - US							4.5
						North		YES	FLAT ALUM	9.0	IV									M1-4: ROUTE MARKER (US HIGHWAYS) - US 16							9.0
						North		YES	FLAT ALUM	4.4	IV									M6-3: DIR ARROW - VERT SINGLE HEAD - US							4.4
						West		YES	FLAT ALUM	4.5	IV									M3-1: DIRECTION MARKER - NORTH - SD							4.5
						West		YES	FLAT ALUM	9.0	IV									M1-5: ROUTE MARKER (STATE/COUNTY ROADS) - SD 79							9.0
						North		YES	FLAT ALUM	4.4	IV									M6-3: DIR ARROW - VERT SINGLE HEAD - SD							4.4
						West		YES	FLAT ALUM	4.5	IV									M3-3: DIRECTIONAL MARKER - SOUTH - SD							4.5
						West		YES	FLAT ALUM	9.0	IV									M1-5: ROUTE MARKER (STATE/COUNTY ROADS) - SD 79							9.0
						West		YES	FLAT ALUM	4.4	IV									M6-1: DIR ARROW - HORIZ SINGLE HEAD - SD							4.4
016 EB	7+84 14' R	7+85 23' R	Right	36	36	South	ROW	YES	FLAT ALUM	9.0	XI	NO								R5-1: DO NOT ENTER	Remove existing sign from luminaire pole. Install new sign on relocated luminaire pole.				9.0	1	

PCN 08RT - PERMANENT SIGNING US HWY 16B & SD HWY 79/CAMBELL																														
HWY	STA & OFFSET Existing	STA & OFFSET New	SIGN					POST										SIGN DESCRIPTION	WORK TO BE DONE	LF of 2.5"	LF of 4.0"	FLAT ALUMINUM SIGN		REMOVE SIGN	REMOVE SIGN FOR RESET & RESET SIGN					
			Side of Road	Width (in)	Height (in)	Direction Facing	Location	New Sign	Sign Type	Square Footage	Sheeting Type	New Post	Length Post #1 (ft)	Offset to center of Post #1 (ft)	Length Post #2 (ft)	Offset to center of Post #2 (ft)	Size (in)					# of Posts	Shear Slip Base			SQFT IV	SQFT XI			
016 WB	1+91 15' L	1+91 25' L	Left	36	36	West	ROW	YES	FLAT ALUM	9.0	XI	NO								R5-1: DO NOT ENTER	Remove existing sign from luminaire pole. Install new sign on relocated luminaire pole.				9.0	1				
016 WB	3+18 20' L	2+90 32' L	Left	66	60	East	ROW	YES	FLAT ALUM	27.5	IV	YES	14.7	32.0						4.0	1	YES	D8-3: WEIGH STATION W/ VERT ARROW	Remove existing sign and posts. Install new sign on new post.		14.7	27.5		1	
016 WB	4+69 16' L	4+40 32' L	Left	36	18	North	ROW	YES	FLAT ALUM	4.5	IV	YES	18.0	32.0						4.0	1	YES	M4-4: TRUCK ROUTE MARKER - US	Remove existing signs and posts. Install new signs on new post.	18.0		4.5		1	
				36	18	North		YES	FLAT ALUM	4.5	IV												M3-4: DIRECTIONAL MARKER - WEST - US			4.5				
				36	36	North		YES	FLAT ALUM	9.0	IV												M1-4: ROUTE MARKER (US HIGHWAYS) - US 16			9.0				
				30	21	North		YES	FLAT ALUM	4.4	IV												M6-3: DIR ARROW - VERT SINGLE HEAD - US			4.4				
				36	18	East		YES	FLAT ALUM	4.5	IV												M3-3: DIRECTIONAL MARKER - SOUTH - SD			4.5				
				36	36	East		YES	FLAT ALUM	9.0	IV												M1-5: ROUTE MARKER (STATE/COUNTY ROADS) - SD 79			9.0				
				30	21	East		YES	FLAT ALUM	4.4	IV												M6-1: DIR ARROW - HORIZ SINGLE HEAD - SD			4.4				
016 WB	5+00 25' L	5+16 36' L	Left			East	ROW	NO		0.0		NO									ADO-2: ADOPT-A-HIGHWAY LITTER CONTROL COURTESY OF	Remove existing signs and posts.				1				
						East		NO		0.0	ADO-1: ADOPT-A-HIGHWAY CLUB SIGN Club Drs. Tucker, Kundra, Holic & Young Eye Care																			
						East		NO		0.0	AD-7: LITTER CREW AHEAD - HINGED																			
016 WB	5+86 23' L	5+90 32' L	Left	96	48	East	ROW	YES	FLAT ALUM	32.0	IV	YES	12.7	32.0	13.7	37.7	4.0	2	YES	D1-2: DESTINATION BOARD - 2 LINES W/ ARROW Rapid City --> <-- Hot Springs	Remove existing sign and posts. Install new sign on new posts.		26.4	32.0		1				
016 WB	7+41 24' L	7+41 26' L	Left			East	ROW	NO		0.0		YES	14.4	26.0	14.8	28.4	2.5	2	YES	W3-4: BE PREPARED TO STOP	Remove existing signs and posts for reset. Reset existing signs on existing posts. Flashing beacon will be removed and reset with the sign assembly.	29.2			1					
						East		NO		0.0	S4-4P: WHEN FLASHING - WORDS																			
																		<b>HWY 79 TOTALS:</b>	<b>58.6</b>	<b>121.2</b>	<b>186.5</b>	<b>18.0</b>	<b>8</b>	<b>2</b>						



Plotting Date: 1/28/2026

PCN 08RT - PERMANENT SIGNING US HWY 16B & CREEK DRIVE																											
HWY	STA & OFFSET Existing	STA & OFFSET New	SIGN					POST						SIGN DESCRIPTION	WORK TO BE DONE	LF of 2.5"	LF of 4.0"	FLAT ALUMINUM SIGN		REMOVE SIGN	REMOVE SIGN FOR RESET & RESET SIGN						
			Side of Road	Width (in)	Height (in)	Direction Facing	Location	New Sign	Sign Type	Square Footage	Sheeting Type	New Post	Length Post #1 (ft)					Offset to center of Post #1 (ft)	Length Post #2 (ft)			Offset to center of Post #2 (ft)	Size (in)	# of Posts	Shear Slip Base	SQFT IV	SQFT XI
016 EB	5+42 25' R	5+20 30' R	Right	36	48	West	ROW	YES	FLAT ALUM	12.0	IV	YES	13.7	30.0			2.5	1	YES	R-NS1: UNMUFFLED DYNAMIC ENGINE BRAKING PROHIBITED	Remove existing sign and posts. Install new sign on new post.	13.7		12.0		1	
016 EB	8+83 26' R	8+83 44' R	Right	36	36	East	ROW	YES	FLAT ALUM	9.0	XI	YES	12.7	44.0			2.5	1	YES	R5-1: DO NOT ENTER	Remove existing sign and posts. Install new sign on new post.	12.7			9.0	1	
<b>CREEK DRIVE TOTALS:</b>																<b>26.4</b>	<b>0.0</b>	<b>12.0</b>	<b>9.0</b>	<b>2.0</b>	<b>0</b>						



Plotting Date: 1/28/2026

**PCN 08RT - PERMANENT SIGNING US HWY 16B & EDWARDS STREET**

HWY	STA & OFFSET Existing	STA & OFFSET New	SIGN				POST						SIGN DESCRIPTION	WORK TO BE DONE	LF of 2.5"	LF of 4.0"	FLAT ALUMINUM SIGN		REMOVE SIGN	REMOVE SIGN FOR RESET & RESET SIGN							
			Side of Road	Width (in)	Height (in)	Direction Facing	Location	New Sign	Sign Type	Square Footage	Sheeting Type	New Post					Length Post #1 (ft)	Offset to center of Post #1 (ft)			Length Post #2 (ft)	Offset to center of Post #2 (ft)	Size (in)	# of Posts	Shear Slip Base	SQFT IV	SQFT XI
016 WB	0+22 100' L	-1+76 97' L	Left	156	48	North	ROW	YES	FLAT ALUM	52.0	IV	YES	13.9	97.0	15.2	104.8	4.0	2	YES	Rec D2-3: Custer State Park 26, Mt Rushmore 30, Crazy Horse 41	Remove existing signs and posts. Install new sign on new posts.		29.1	52.0		1	
016 WB	-1+76 97' L	0+22 100' L	Left	186	48	North	ROW	YES	FLAT ALUM	62.0	IV	YES	13.9	100.0	15.4	109.3	4.0	2	YES	D1-3: Western Dakota Tech 3, Regional Airport 8, BHSU - Rapid City	Remove existing signs and posts. Install new sign on new posts.		29.3	62.0		1	
016 WB	2+33 32' R	2+57 32' R	Right	36	36	South	ROW	YES	FLAT ALUM	9.0	XI	YES	12.7	32.0			2.5	1	YES	R5-1: DO NOT ENTER	Remove existing signs and posts. Install new sign on new post.	12.7			9.0	1	
016 WB	1+35 14' L	1+26 21' L	Left	36	36	North	ROW	YES	FLAT ALUM	9.0	XI	NO								R5-1: DO NOT ENTER	Remove existing sign from luminaire pole. Install new sign on relocated luminaire pole.				9.0	1	
016 EB	1+78 29' L		Left			North	ROW	NO		0.0		NO								D7-1C: Black Hills State University Center Left at Signal	Remove existing sign and posts.					1	
<b>EDWARDS STREET TOTALS:</b>															<b>12.7</b>	<b>58.4</b>	<b>114.0</b>	<b>18.0</b>	<b>5</b>	<b>0</b>							
<b>CREEK DRIVE TOTALS:</b>															<b>26.4</b>	<b>0.0</b>	<b>12.0</b>	<b>9.0</b>	<b>2</b>	<b>0</b>							
<b>HWY 79 TOTALS:</b>															<b>58.6</b>	<b>121.2</b>	<b>186.5</b>	<b>18.0</b>	<b>8</b>	<b>2</b>							
<b>DAN CHRISTY LANE TOTALS:</b>															<b>12.6</b>	<b>0.0</b>	<b>0.0</b>	<b>9.0</b>	<b>1</b>	<b>1</b>							
<b>PROJECT TOTALS:</b>															<b>110.3</b>	<b>179.6</b>	<b>312.5</b>	<b>54.0</b>	<b>16</b>	<b>3</b>							

# SIGNING LAYOUT

## US Hwy 16 WB & Dan Christy Lane

SD DOT	PROJECT	SECTION	SHEET
	NH 016B(03)64	S	9/26

Plotting Date: 1/26/2026

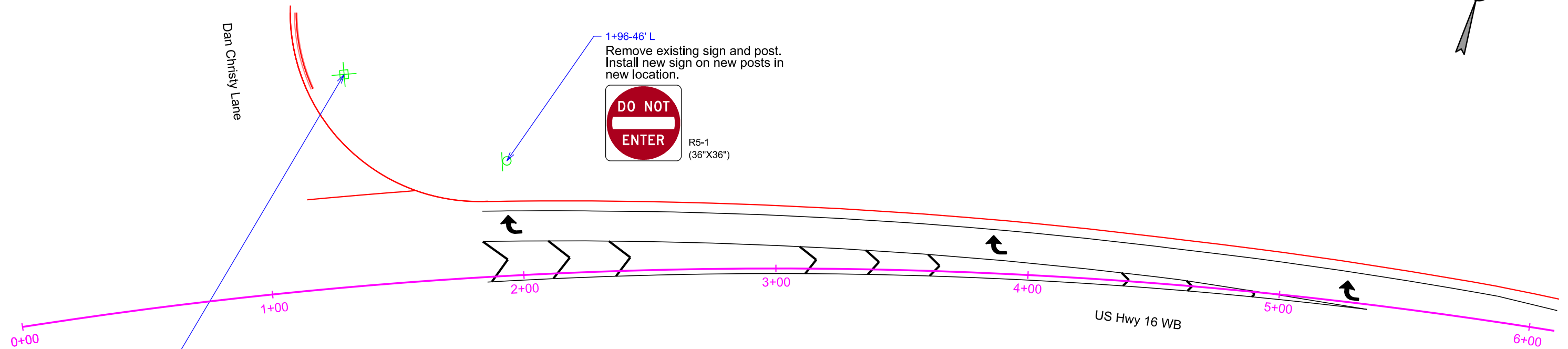
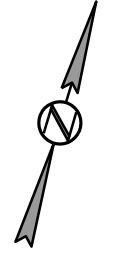

1+96-46' L  
Remove existing sign and post.  
Install new sign on new posts in  
new location.



1+36-84' L  
Remove signs and post for reset.  
Reset existing signs on existing  
post in new location.



# SIGNING LAYOUT

## US Hwy 16 EB & SD Hwy 79

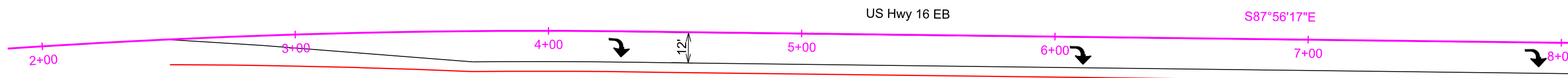

1+97-26' R  
Remove existing signs and posts. Install new sign on new posts at new location.



D1-2 (114\"/>

RAWS1 - 3+26-30' R  
Remove existing signs and posts for reset. Reset existing signs on new post at new location.  
Flashing beacon will be removed for reset and reset above signs.



5+63-32' R  
Remove existing signs and posts. Install new signs on new posts at new location.

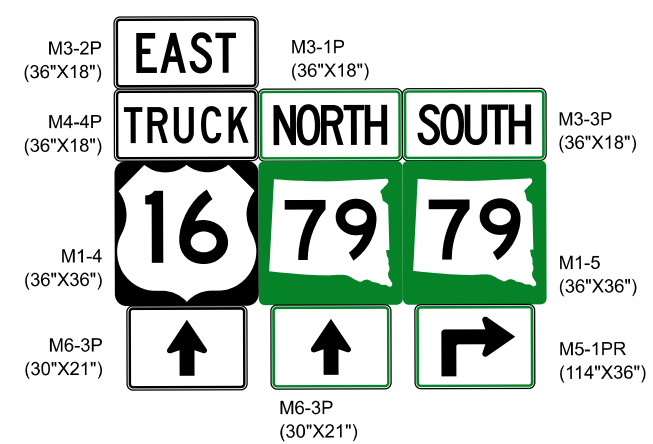

7+85-23' R  
Remove existing sign from existing luminaire pole. Install new sign on luminaire pole at new location.

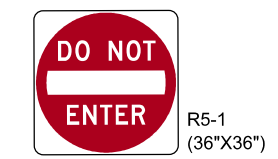

# SIGNING LAYOUT

## US Hwy 16 WB & SD Hwy 79/Cambell St



Remove existing sign from existing luminaire pole. Install new sign on luminaire pole at new location.  
1+91-25' L



Remove existing signs and posts. Install new sign on new posts at new location.  
2+90-32' L

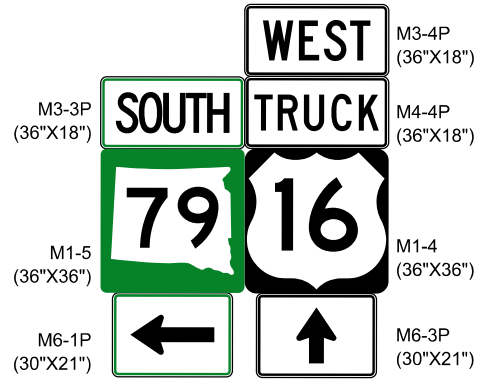

Remove existing signs and posts. Install new signs on new posts at new location.  
4+40-32' L



Remove existing signs and posts. Install new sign on new posts at new location.  
5+90-32' L



Remove existing signs and posts for reset. Reset existing signs on new post at new location.  
Flashing beacon will be removed for reset and reset above signs.  
RAWS2 - 7+41-26' L

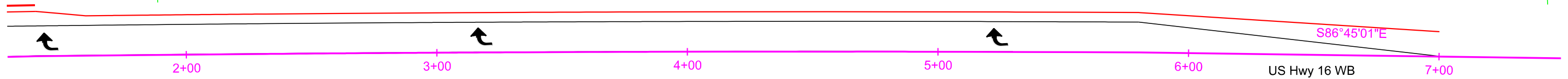

# SIGNING LAYOUT

## US Hwy 16 EB & Creek Drive

SD DOT	PROJECT	SECTION	SHEET
	NH 016B(03)64	S	12/26
Plotting Date: 1/26/2026			

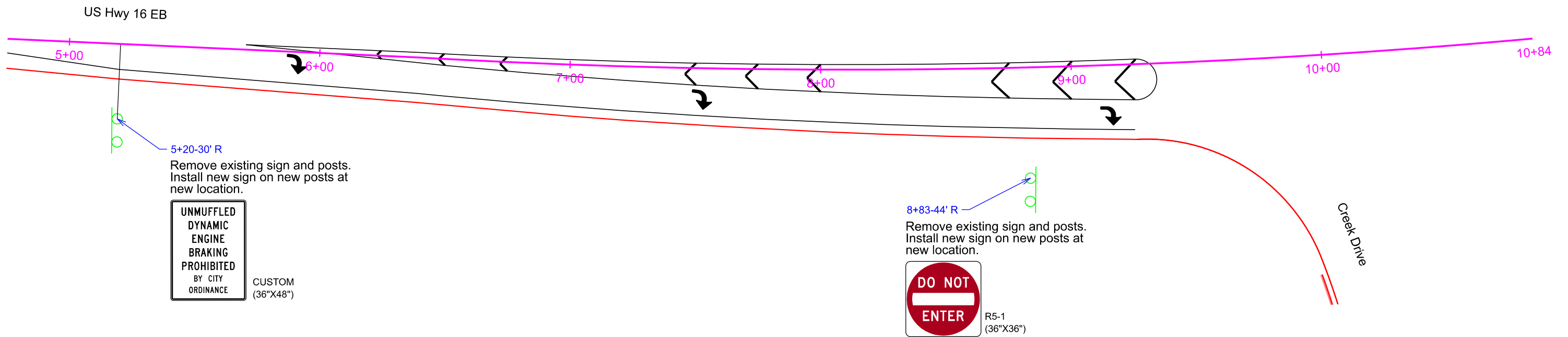

# SIGNING LAYOUT

## US Hwy 16 EB & I90 Service Road

SD DOT	PROJECT	SECTION	SHEET
	NH 016B(03)64	S	13/26

Plotting Date: 1/26/2026



**Custer State Park 26**  
**Mt Rushmore 30**  
**Crazy Horse 41**

Recreation D2-3  
(156"x48")

Remove existing sign and posts.  
Install new sign on new posts at existing location.

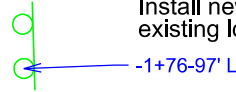

**↑ Western Dakota Tech 3**  
**↑ Regional Airport 8**  
**← BHSU - Rapid City**

D1-3  
(186"x48")

Remove existing sign and posts.  
Install new sign on new posts at existing location.

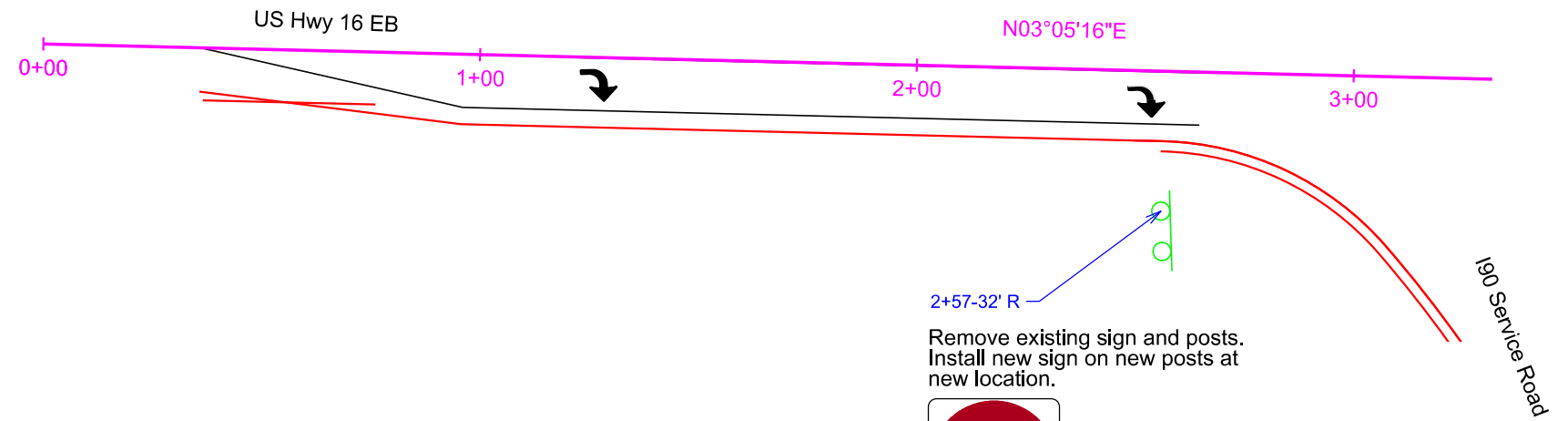
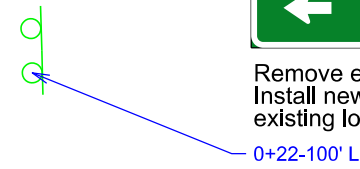

Remove existing sign and posts.  
Install new sign on new posts at new location.



R5-1  
(36"x36")

# SIGNING LAYOUT

## US Hwy 16 WB & Edwards Street

SD DOT	PROJECT	SECTION	SHEET
	NH 016B(03)64	S	14/26
Plotting Date: 1/26/2026			

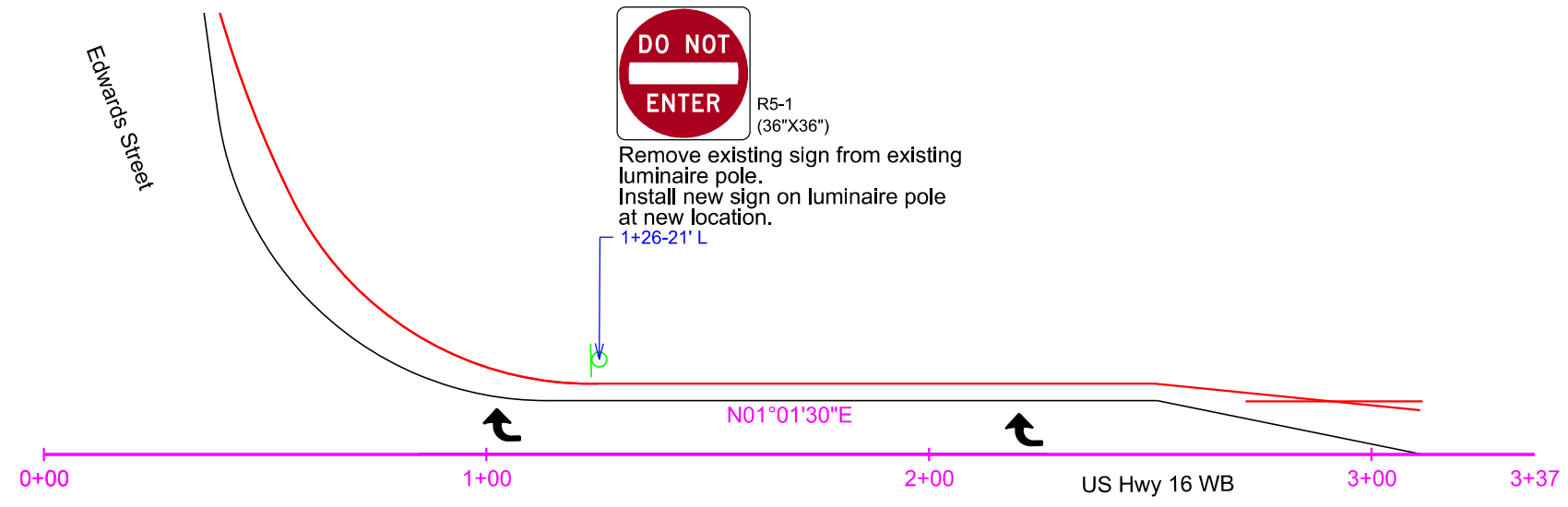

# SIGN DESIGN DETAILS

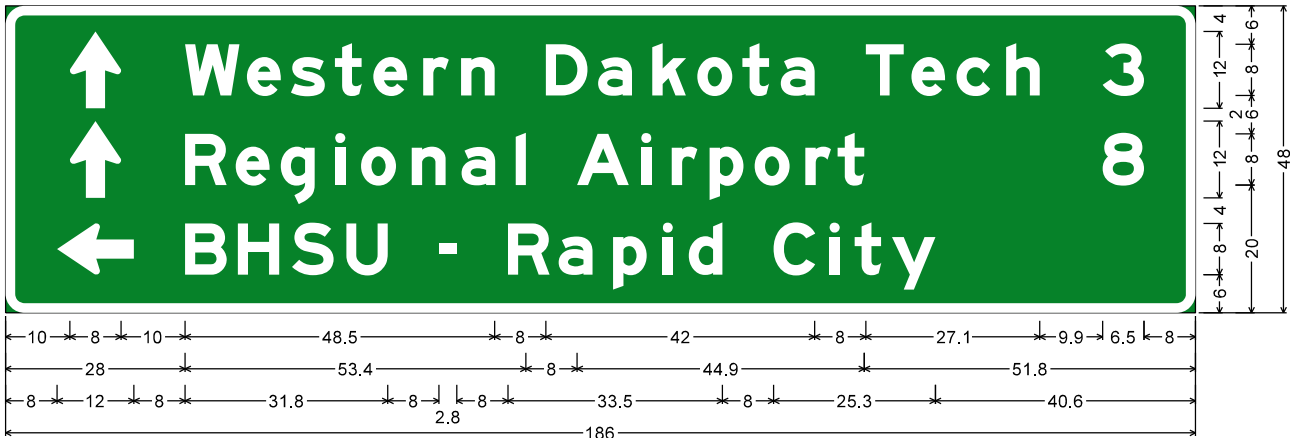

D1-3;  
 Sign Type : Flat Alum;  
 Legend Type : Type IV - High Intensity;  
 Background Type : Type IV - High Intensity;  
 3.0" Radius, 1.5" Border, White on Green;  
 Standard Arrow Custom 12.0" X 8.0" 90°; "Western Dakota Tech", E Mod 2K; "3", E Mod 2K;  
 Standard Arrow Custom 12.0" X 8.0" 90°; "Regional Airport", E Mod 2K; "8", E Mod 2K; Standard Arrow Custom 12.0" X 8.0" 180°;  
 "BHSU - Rapid City", E Mod 2K;

Table of letter and object lefts

↑	W	e	s	t	e	r	n	D	a	k	o	t	a	T	e	c	h	3
10.0	28.0	37.8	44.6	51.5	57.5	65.3	71.1	84.5	92.6	101.1	108.1	115.1	121.1	134.5	141.6	148.6	156.4	171.5
↑	R	e	g	i	o	n	a	I	A	i	r	p	o	r	t	8		
10.0	28.0	36.0	43.0	51.5	55.6	63.5	71.3	79.8	89.4	99.4	104.1	110.0	117.1	125.0	130.0	171.5		
←	B	H	S	U	-	R	a	p	i	d	C	i	t	y				
8.0	28.0	36.3	44.8	53.3	67.8	78.5	86.5	95.0	102.8	106.8	120.0	128.8	132.8	138.5				

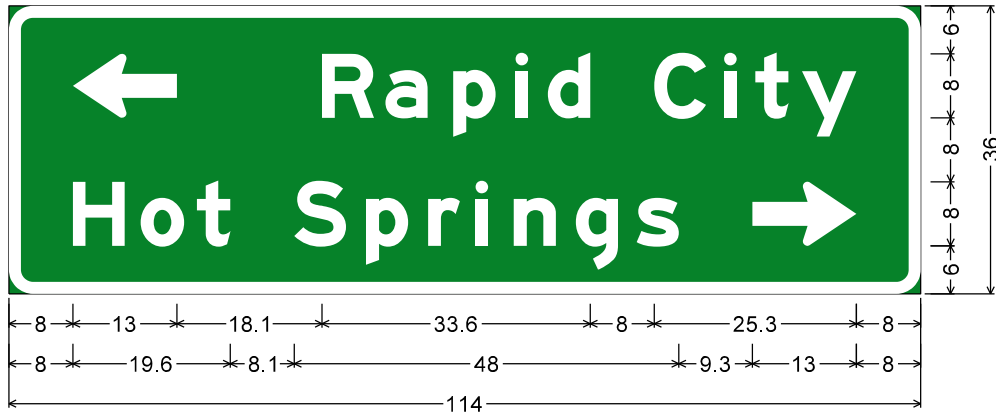

D1-2;  
 Sign Type : Flat Alum;  
 Legend Type : Type IV - High Intensity;  
 Background Type : Type IV - High Intensity;  
 3.0" Radius, 1.5" Border, White on Green;  
 Standard Arrow Custom 13.0" X 8.0" 180°; "Rapid City", E Mod 2K;  
 "Hot Springs", E Mod 2K; Standard Arrow Custom 13.0" X 8.0" 0°;

Table of letter and object lefts

←	R	a	p	i	d	C	i	t	y	
8.0	39.1	47.1	55.5	63.4	67.4	80.6	89.4	93.4	99.1	
H	o	t	S	p	r	i	n	g	s	⇒
8.0	16.5	23.5	35.6	44.6	52.4	58.4	63.1	70.9	78.5	93.0

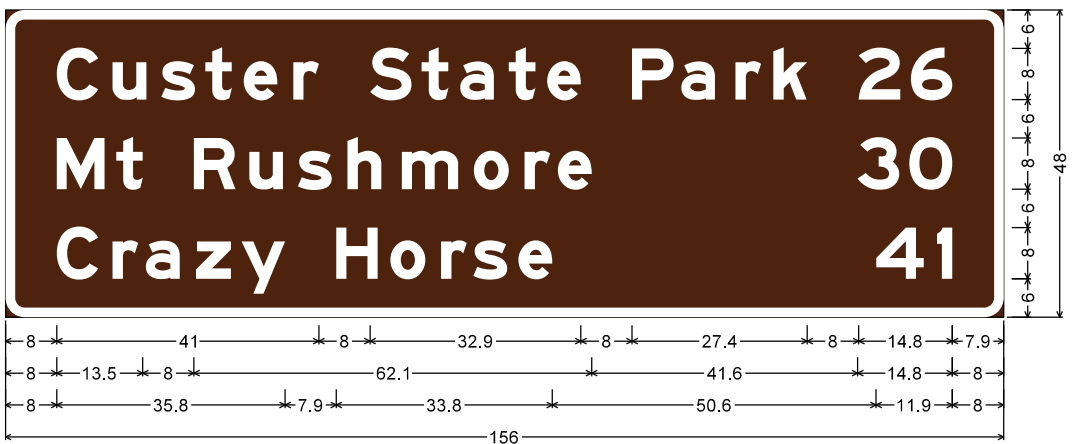

Rec. D2-3;  
 Sign Type : Flat Alum.;  
 Legend Type : Type IV - High Intensity;  
 Background Type : Type IV - High Intensity;  
 3.0" Radius, 1.5" Border, White on Brown;  
 "Custer State Park", E Mod 2K; "26", E Mod 2K; "Mt Rushmore", E Mod 2K; "30", E Mod 2K;  
 "Crazy Horse", E Mod 2K; "41", E Mod 2K;

Table of letter and object lefts

C	u	s	t	e	r	S	t	a	t	e	P	a	r	k	2	6
8.0	16.8	24.4	31.3	37.3	45.0	57.0	65.0	71.0	78.6	84.6	97.9	105.6	114.1	120.0	133.4	141.5
M	t	R	u	s	h	m	o	r	e	3	0					
8.0	17.3	29.5	38.1	45.8	53.5	61.9	73.3	81.1	86.4	133.3	141.3					
C	r	a	z	y	H	o	r	s	e	4	1					
8.0	16.8	21.9	29.8	36.9	51.8	60.1	68.1	73.1	80.1	136.1	145.6					

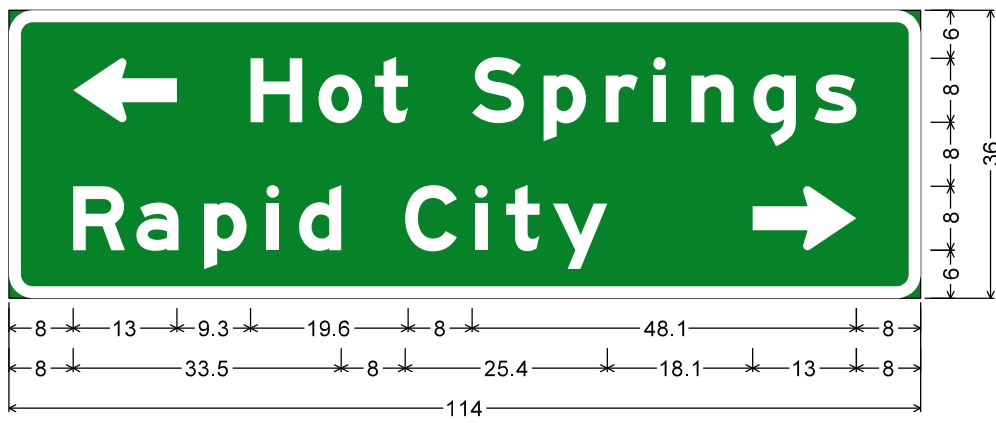

D1-2;  
 Sign Type : Flat Alum.;  
 Legend Type : Type IV - High Intensity;  
 Background Type : Type IV - High Intensity;  
 3.0" Radius, 1.5" Border, White on Green;  
 Standard Arrow Custom 13.0" X 8.0" 180°; "Hot Springs", E Mod 2K;  
 "Rapid City", E Mod 2K; Standard Arrow Custom 13.0" X 8.0" 0°;

Table of letter and object lefts

←	H	o	t	S	p	r	i	n	g	s
8.0	30.3	38.8	45.8	57.9	66.9	74.6	80.5	85.4	93.1	100.8
R	a	p	i	d	C	i	t	y	⇒	
8.0	16.0	24.4	32.1	36.3	49.5	58.3	62.1	68.0	93.0	

# SIGN DESIGN DETAILS

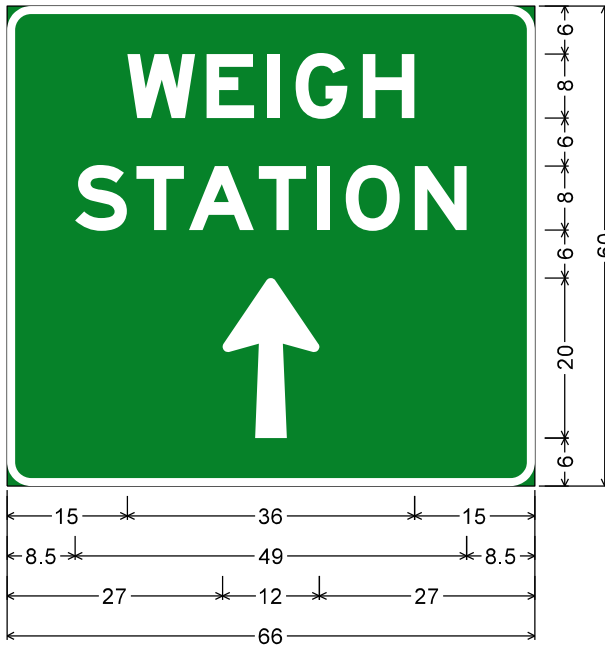

D8-3;  
 Sign Type : Flat Alum.;  
 Legend Type : Type IV - High Intensity;  
 Background Type : Type IV - High Intensity;  
 3.0" Radius, 1.0" Border, White on Green;  
 "WEIGH", E Mod 2K; "STATION", E Mod 2K;  
 Arrow Custom - 20.0" 90°;

Table of letter and object lefts

W	E	I	G	H		
15.0	25.0	32.5	36.1	44.5		
S	T	A	T	I	O	N
8.5	16.3	22.8	31.5	38.9	42.4	51.0
↑						
27.0						

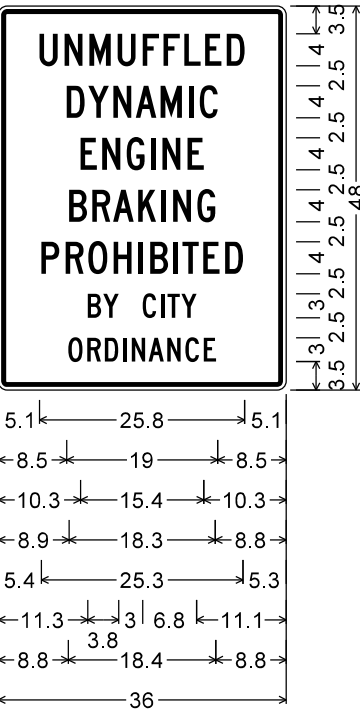

Custom;  
 Sign Type : Flat Alum.;  
 Legend Type : Opaque;  
 Background Type : Type IV - High Intensity;  
 1.1" Radius, 0.6" Border, 0.4" Indent, Black on White;

"UNMUFFLED", C 2K;  
 "DYNAMIC", C 2K;  
 "ENGINE", C 2K;  
 "BRAKING", C 2K;  
 "PROHIBITED", C 2K;  
 "BY CITY", C 2K;  
 "ORDINANCE", C 2K;

Table of letter and object lefts

U	N	M	U	F	F	L	E	D	
5.1	8.3	11.4	15.0	18.0	20.6	23.3	25.9	28.6	
D	Y	N	A	M	I	C			
8.5	11.3	14.4	17.3	20.4	23.9	25.3			
E	N	G	I	N	E				
10.3	13.0	16.0	19.1	20.5	23.6				
B	R	A	K	I	N	G			
8.9	11.8	14.4	17.5	20.4	21.9	24.9			
P	R	O	H	I	B	I	T	E	D
5.4	8.5	11.3	14.5	17.5	19.0	21.9	23.0	25.6	28.4
B	Y								
11.3	13.1								
C	I	T	Y						
18.0	20.4	21.1	22.9						
O	R	D	I	N	A	N	C	E	
8.8	11.1	13.4	15.6	16.8	18.8	21.1	23.4	25.8	

# SIGN BASE DETAILS

SD DOT	PROJECT	SECTION	SHEET
	NH 016B(03)64	S	17/26
Plotting Date: 1/26/2026			

## BREAKAWAY SIGN SUPPORTS

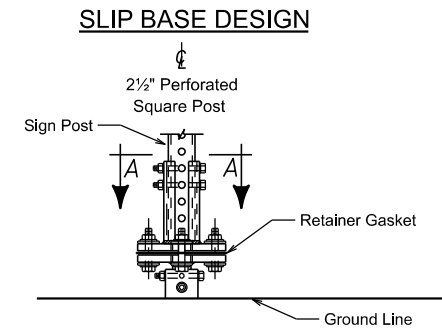

### ELEVATION

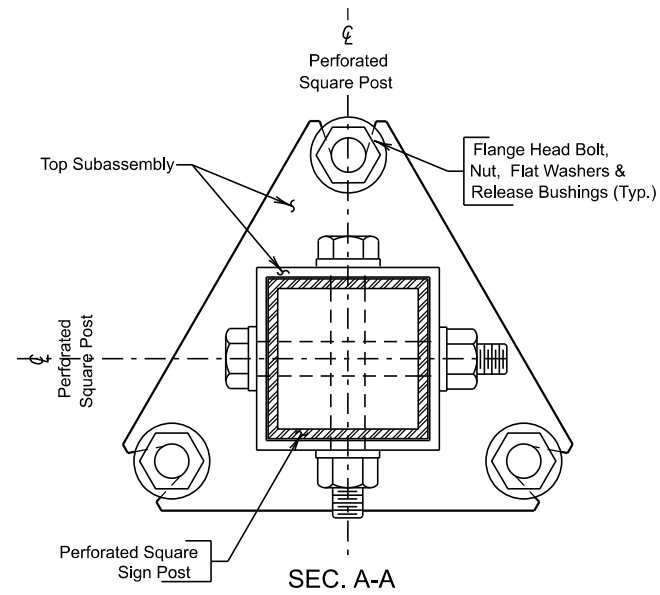

## SIGN BASE DETAILS FOR A 2 1/2" SIGN POST

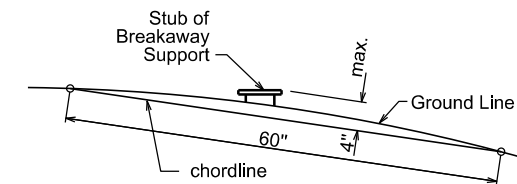
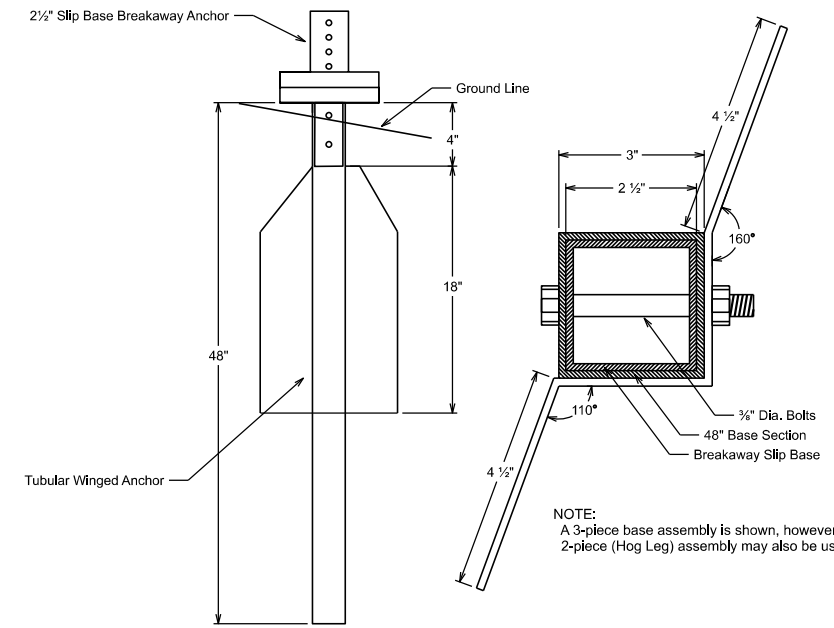

BREAKAWAY SUPPORT STUB CLEARANCE DIAGRAM

NOTE: The top of breakaway support will NOT extend more than 4" max above the chordline within a 60" chord.

### General Notes:

1. Design Specification: AASHTO Standard Specifications for Structural Supports for Highway Signs, Luminaires and Traffic Signals, Latest Edition.
2. The manufacturer will provide certification that the posts and hardware furnished have essentially the same chemistry, mechanical properties and geometry as that used in the FHWA tests, and that it will meet the FHWA change in velocity requirements.
3. The manufacturer will also provide certification that the breakaway system furnished will develop the full shear and bending yield strength of the sign post section being spliced.
4. All posts will be galvanized in accordance with ASTM A653, Des. G-90.
5. All hardware will be galvanized in accordance with ASTM A153.

# TYPICAL SIGN BASE PLACEMENT

	PROJECT	SECTION	SHEET
	NH 016B(03)64	S	18/26

Plotting Date: 1/26/2026

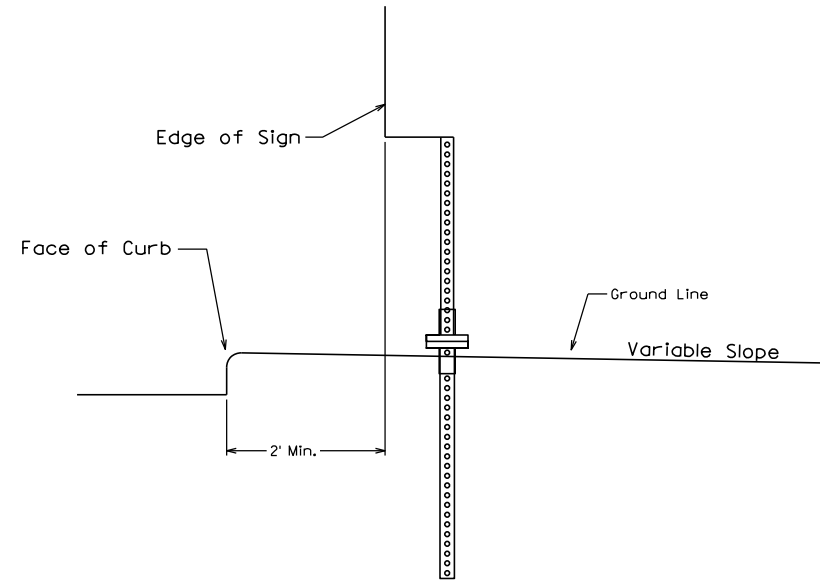

URBAN LOCATION WITH 1 POST  
(Drawing shown from face of sign)

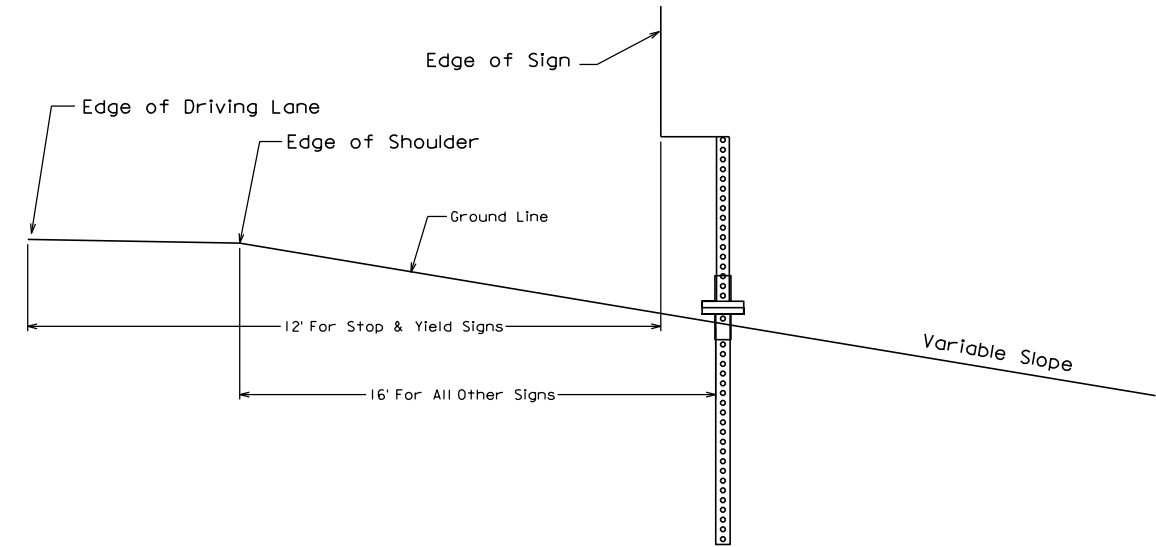

RURAL LOCATION WITH 1 POST  
(Drawing shown from face of sign)

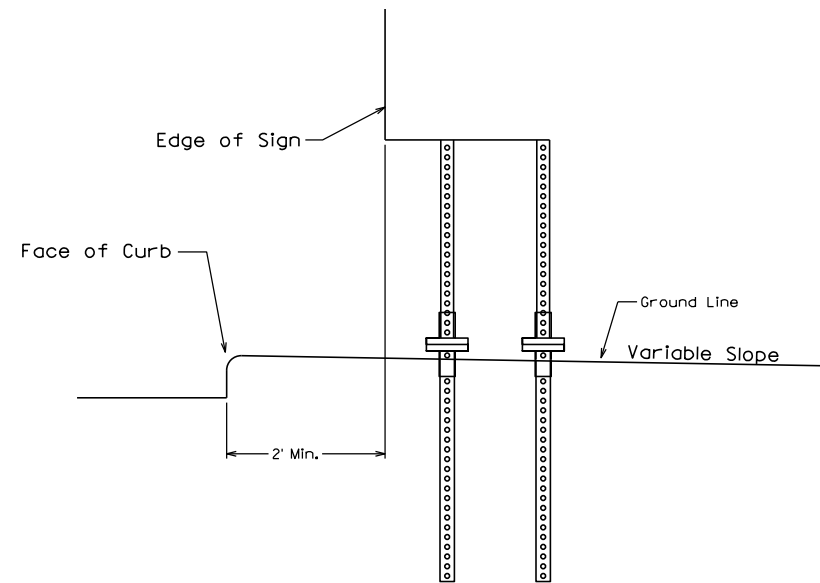

URBAN LOCATION WITH 2 POSTS  
(Drawing shown from face of sign)

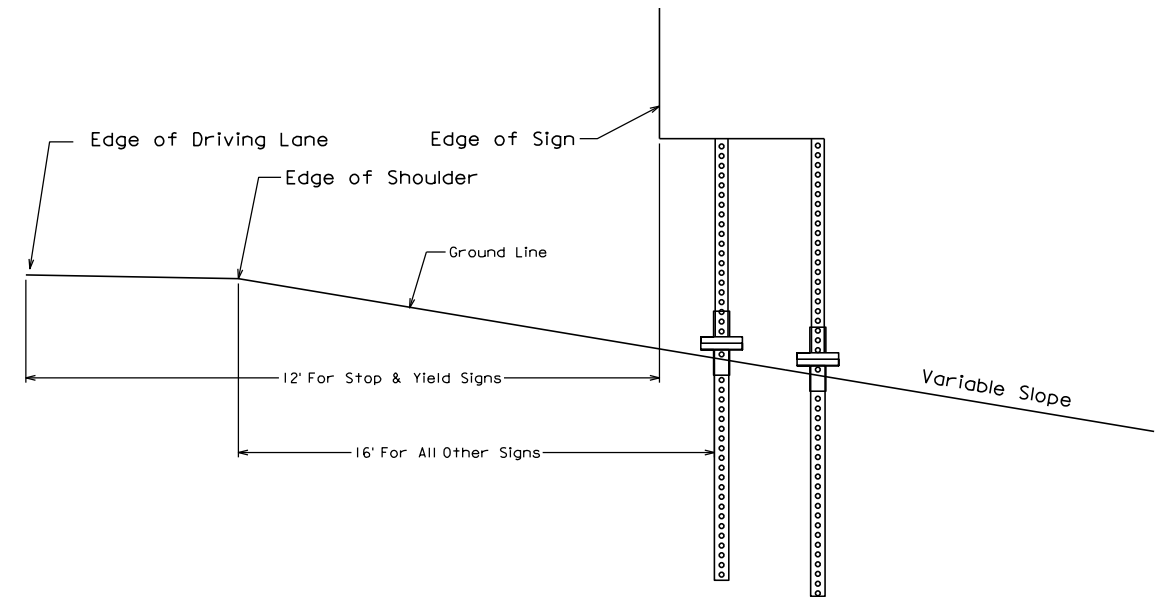

RURAL LOCATION WITH 2 POSTS  
(Drawing shown from face of sign)

# MASSH 400 DETAILS

## BASE, FOOTING, AND POST

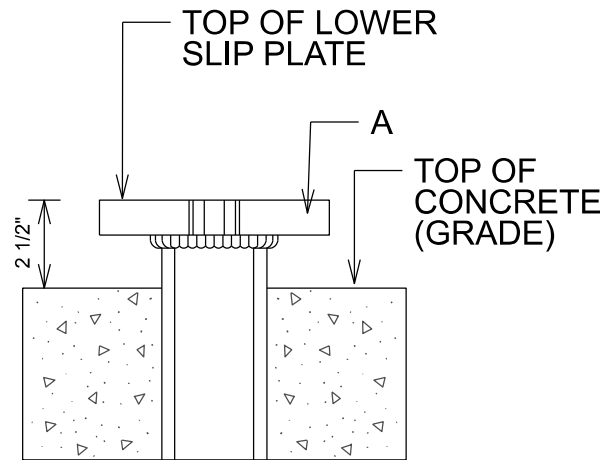

UPPER POST

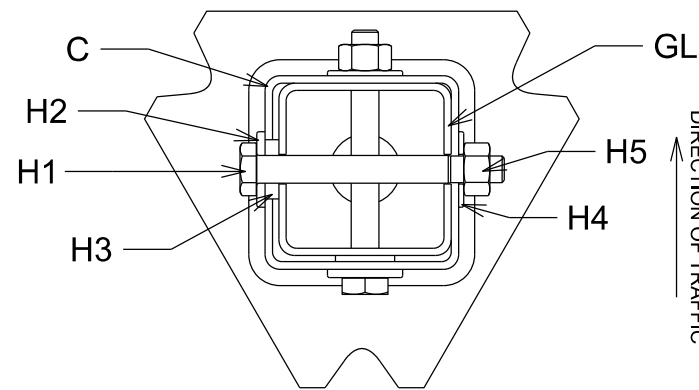
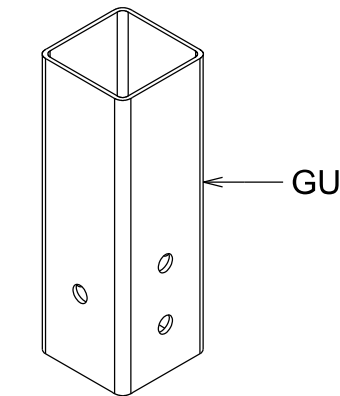

SECTION VIEW

CONCRETE INSTALLATION DETAIL

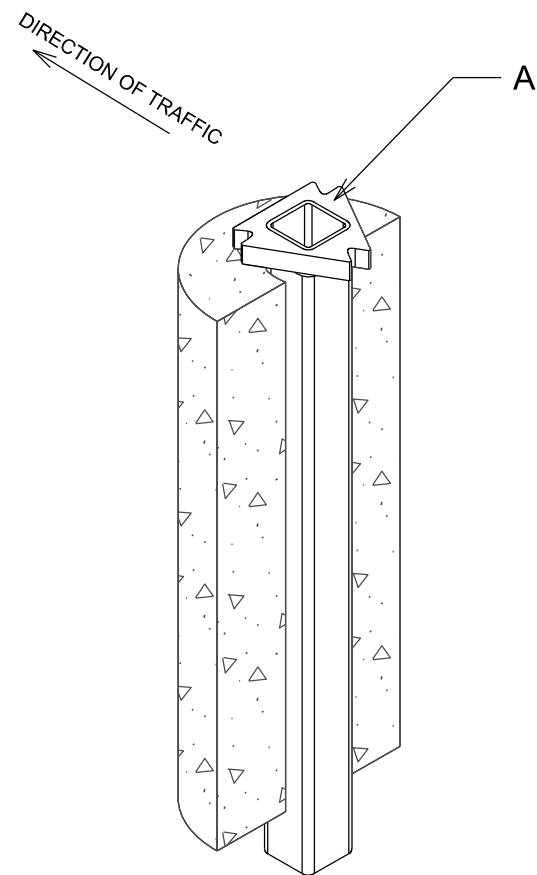

SLIP BASE ASSEMBLY

\* Concrete footings will be 18" in diameter and 48" deep.

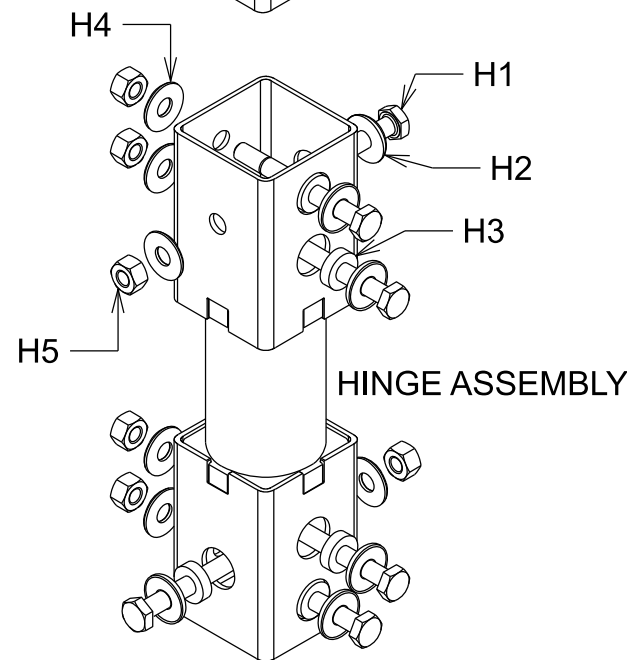

HINGE ASSEMBLY

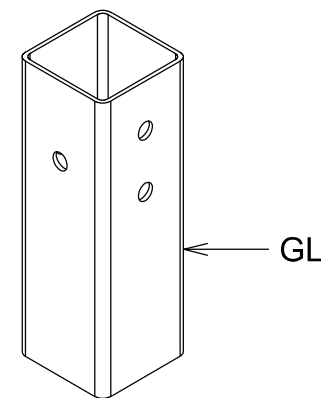

LOWER POST

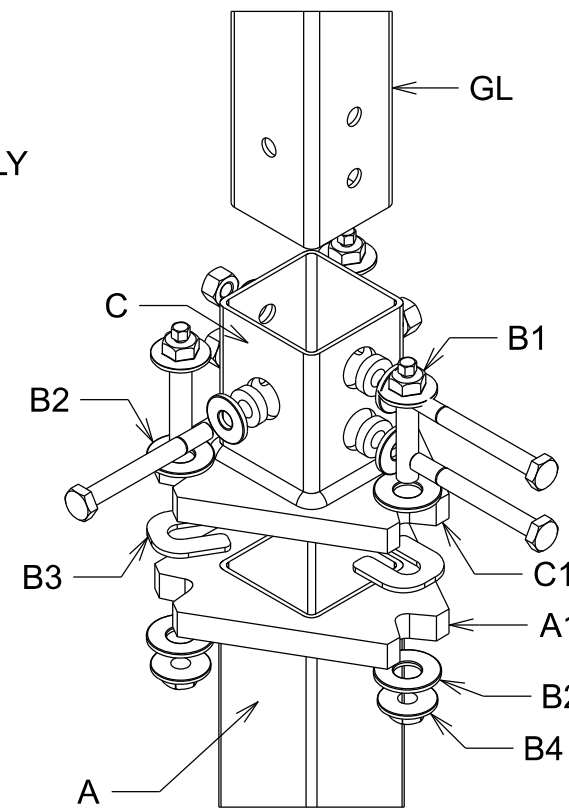

SLIP BASE ASSEMBLY

MULTI-DIRECTIONAL HINGE ASSEMBLY

### INSTALLATION PROCEDURE

TOOLS NEEDED: 1-1/16" SOCKET & BOX WRENCH (for post attachment hardware), 1-1/8" SOCKET & BOX WRENCH & 9/16" SOCKET (for slip plate hardware).

1. Install Triangular Unibase Anchor (A) plumb & squared up with the road. The most common orientation is with the point of the triangular slip plate facing oncoming traffic. On multi-leg installations, be sure that all Unibase Anchors are squared & lined up with each other.
2. Depth of embedment to leave 2-1/2" ( $\pm 1/2"$ ) from grade to bottom of Lower Slip Plate of Unibase (A).
3. Place one each Teflon coated Slip Washer (B3) on top of Lower Slip Plate of Unibase (A) at each notched point with open end of slot facing center of triangular slip plate. Leave enough room between the closed ends of the slot/notch to allow  $\text{\O}3/4"$  Redi-Torque Bolt (B1) to pass through.
4. Place Upper Slip Plate (C) onto the three Slip Washers (B3) properly indexed so that square post receiver portion is squared up with road.
5. Slide 1 of the 7/8" Flat Washer (B2) on to each Redi-Torque Bolt (B1) then insert down through notched points of Upper Slip Plate (C), slot of Slip Washer (B3) and notched point of Lower Slip Plate of Unibase (A1). Slide 1 each 7/8" Flat Washer (B2) followed by threading 1 each 3/4" Flange Nut (B4) on to each Redi-Torque Bolt (B1) and tighten using the 1-1/8" (larger) hex and NOT the 9/16" (smaller) hex. This is done to help flatten any galvanizing buildup and ensure all three hardware sets will be tight. The Redi-Torque Bolt smaller hex head is removed later.
6. If using a template to drill the holes in the posts make sure that the two thru-holes on the side for the slip base post receiver are on the same sides of the posts as the two thru-holes for the hinge post receiver, and that the single thru-holes for the slip base post receiver are on the same sides of the posts as the single thru-holes for the hinge post receiver. On a flat surface, insert upper sign post (GU) and lower post (GL) into opposite ends of a hinge assembly making sure that the sets of post holes match up with with hardware holes in the hinge. Insert the bolt (H1) through the 1-3/4" diameter washer (H2) then a 1-3/8" diameter shoulder washer (H3) then into a post receiver (large hole) as shown in diagram. Add the 5/8" flat washer (H4) and hex nut (H5) and finger tighten. Do the same for the other 5 sets of hardware and receiver holes. Tighten them until the 1-3/4" diameter washer (H2) is flat against the outside post receiver socket of the hinge assembly, beginning with the nut closest to the end of the post, followed by the next one on that same side, ending with the single one side. Repeat steps above for any additional post assemblies.

7. Insert post assembly with lower post (GL) at bottom and upper sign panel post (GU) at top into the appropriate Upper Slip Plate (C) receiver, orienting post in such a way as the two bolt heads face the side of the slip base post receiver containing the point of the triangular slip plate. Insert the bolt (H1) through the 1-3/4" diameter washer (H2) then a 1-3/8" diameter shoulder washer (H3) then into a post receiver (large hole) as shown in diagram. Add the 5/8" flat washer (H4) and hex nut (H5) and finger tighten. Do the same for the other 2 sets of hardware and receiver holes. Tighten them until the 1-3/4" diameter washer (H2) is flat against the outside post receiver socket (C), beginning with the nut closest to the end of the post, followed by the next one on that same side, ending with the single one side. Repeat steps above for any additional slip base assemblies.

8. Loosen the three bolts connecting the Lower Slip Plate of Unibase (A) and Upper Slip Plate (C) using the 1-1/8" (larger) hex then finger tighten making sure the Slip Washers (B3) are pushed in snug against the Redi-Torque Bolts (B1). Finally use a 9/16" wrench on the 9/16" (smaller) hex until it snaps off which results in the designed torque value.

### REINSTALLATION AFTER IMPACT

- \* Gather all materials to a safe area and inspect all parts including welds to determine which parts, if any should be replaced. New slip base hardware should be used. Make sure all hinges are tight and square.
- \* Follow Installation Procedures 3 - 8 above.

# MASSH 400 DETAILS

## SIGN MOUNTING

SD DOT	PROJECT	SECTION	SHEET
	NH 016B(03)64	S	20/26

Plotting Date: 1/26/2026

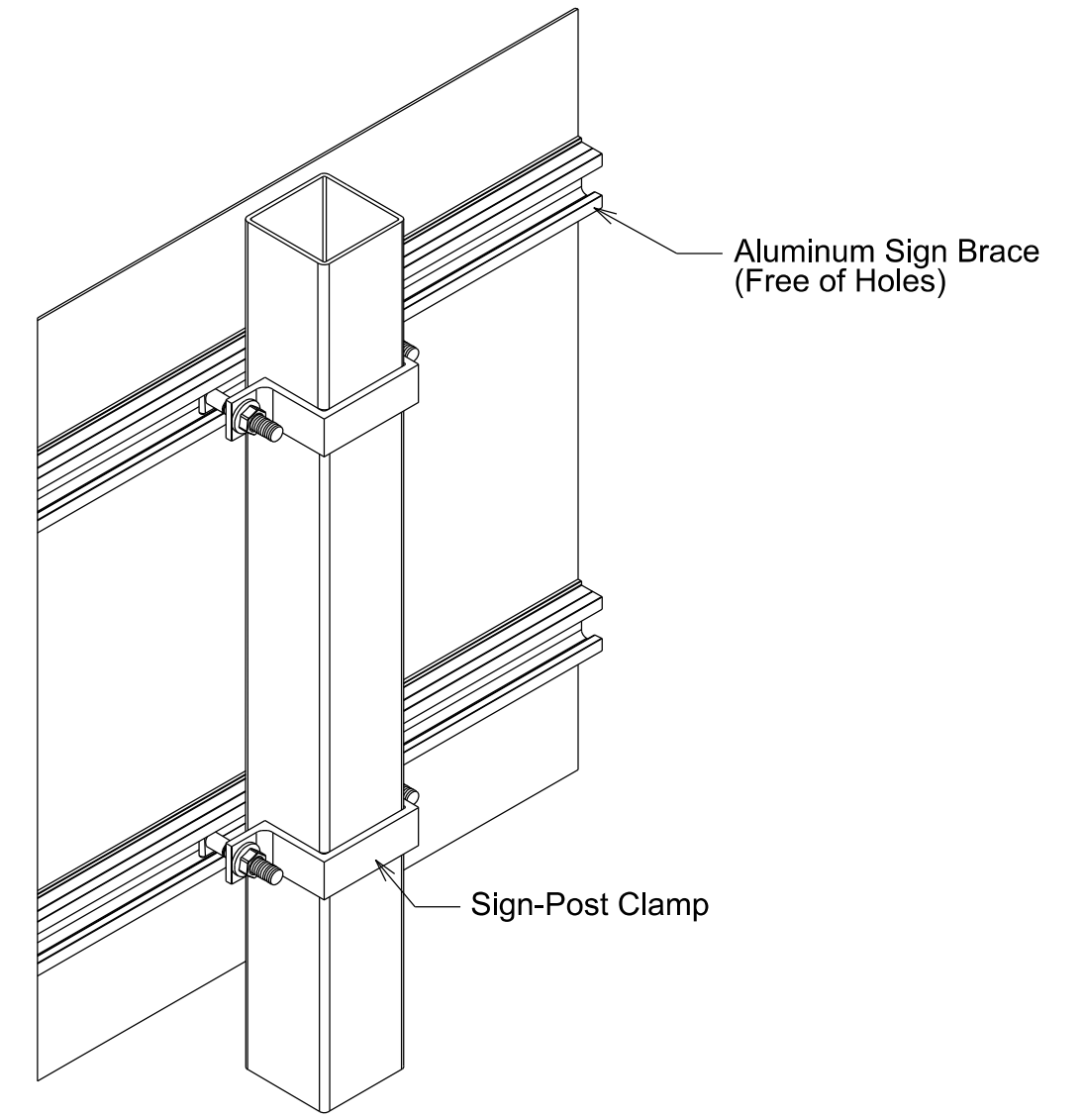
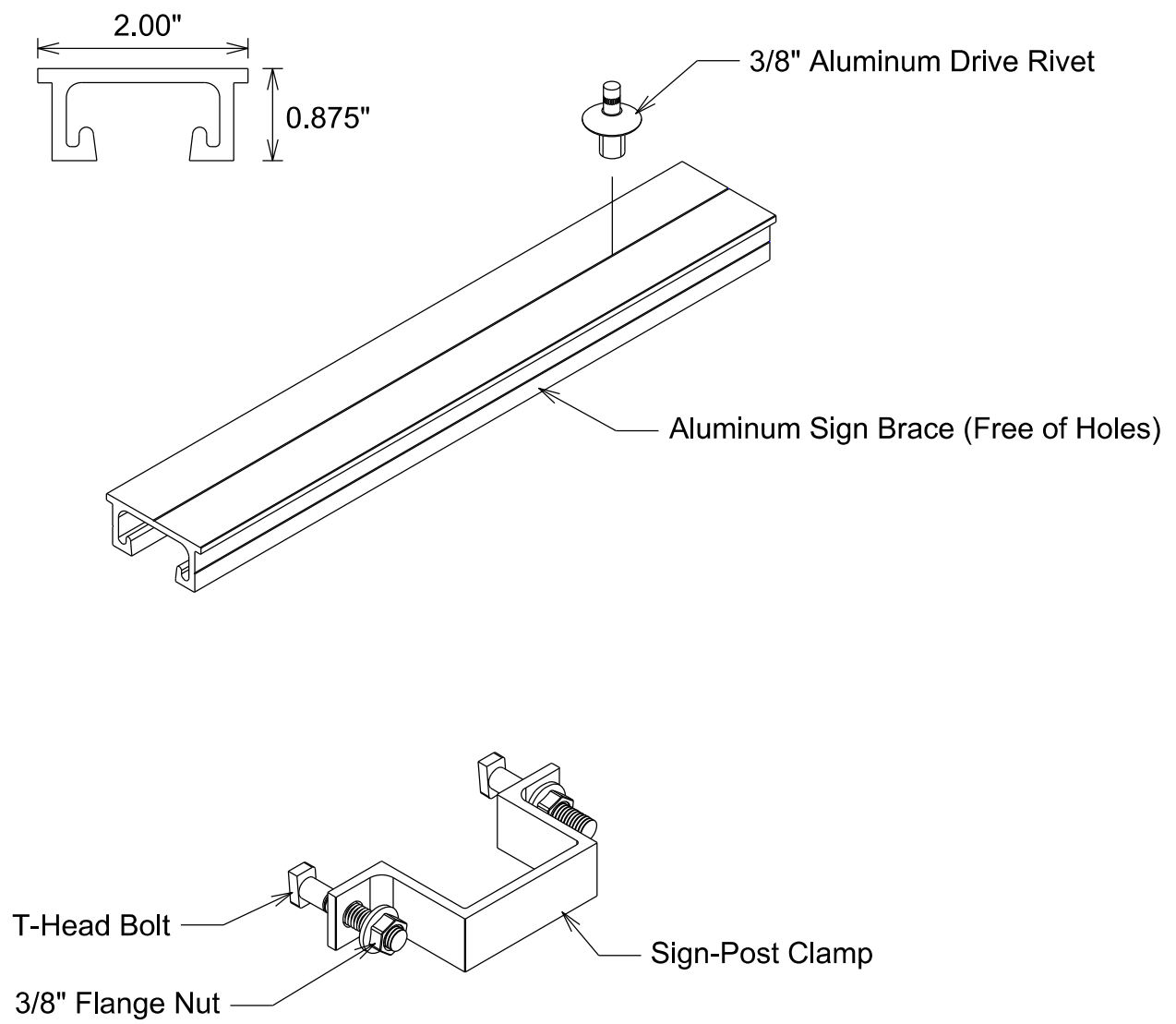

### MOUNTING INSTRUCTIONS:

Fasten the aluminum sign bracing to the flat sign panel using 3/8" aluminum drive rivets. Drive rivets will be install with a spacing of 18" between rivets.

With the sign panel in position against the sign posts, install the T-head bolts into the aluminum sign bracing channel. Then install the sign-post clamp over the sign post while guiding the T-head bolts into the clamps' holes. Make sure the sign -post clamp is positioned against the sign post and secure using a flange nut. Tighten nut until snug.

Repeat for all additional clamps. Clamps will be installed at each aluminum sign brace and sign post junction.

# MASSH 400 DETAILS

## POST LENGTHS

	PROJECT	SECTION	SHEET
	NH 016B(03)64	S	21/26

Plotting Date: 1/26/2026

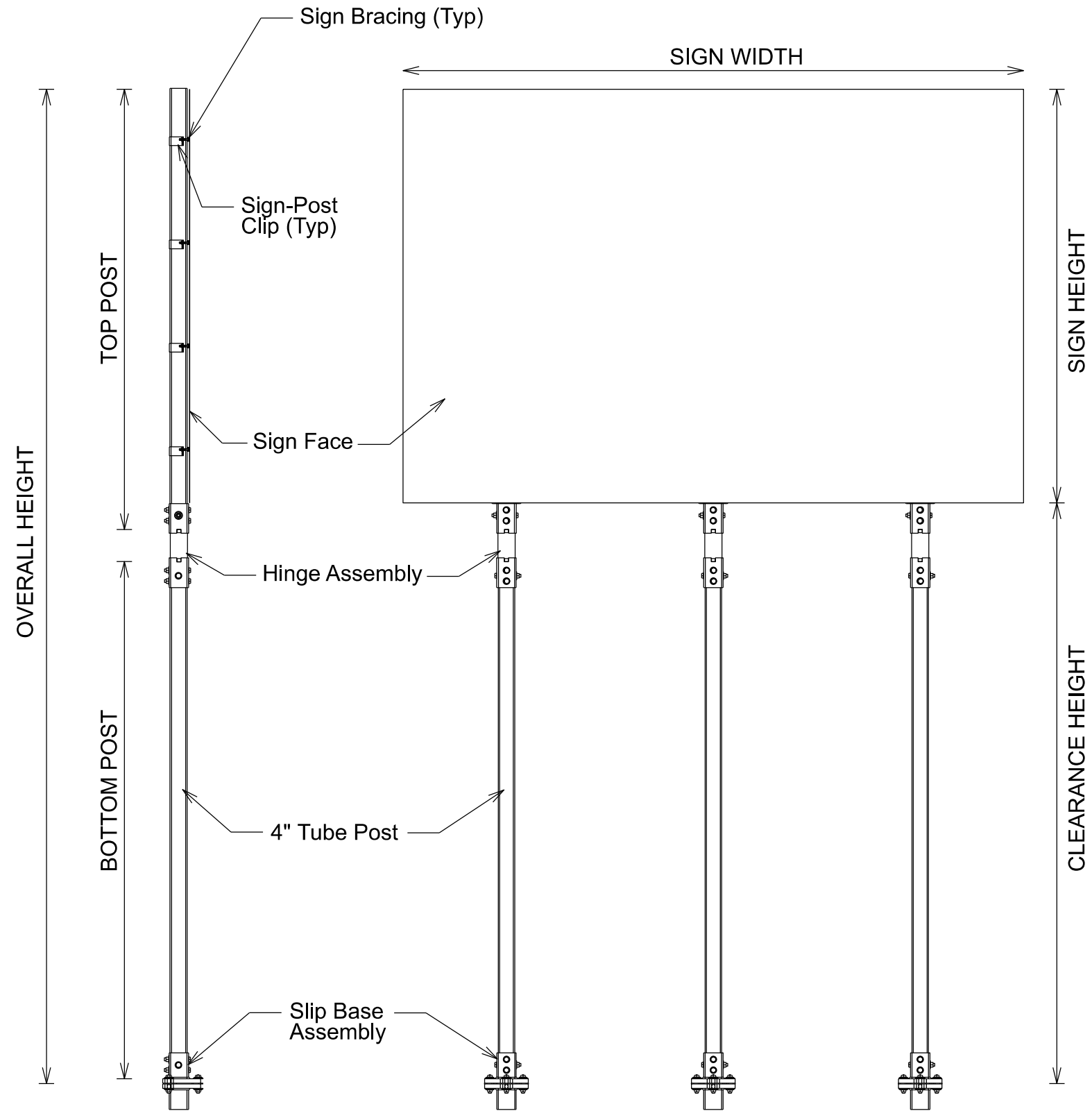

$TOP\ POST = SIGN\ HEIGHT + 6"$   
 $BOTTOM\ POST = CLEARANCE\ HEIGHT - 12"$   
 $CLEARANCE\ HEIGHT = OVERALL\ HEIGHT - SIGN\ HEIGHT$

TOP POST needs holes in one end for attachment.  
 BOTTOM POST needs holes in both ends for attachment.

NOTE: Hinge assembly will NOT be required for signs mounted on a single post.

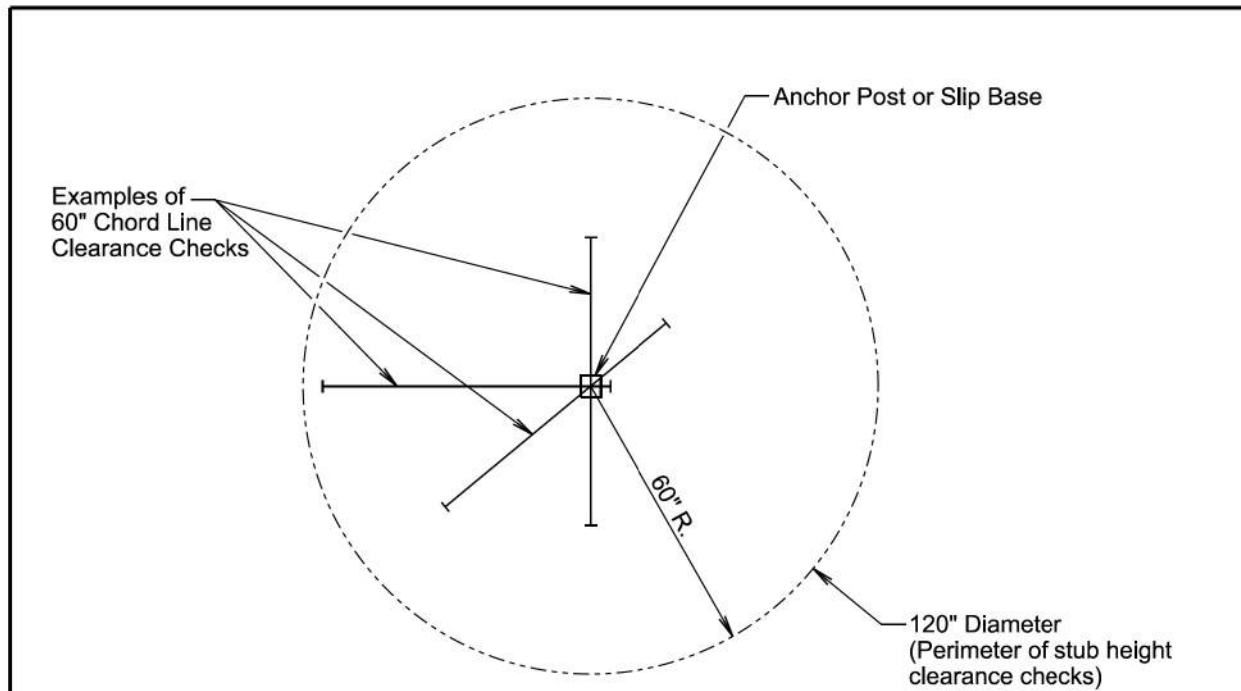

**PLAN VIEW**  
(Examples of stub height clearance checks)

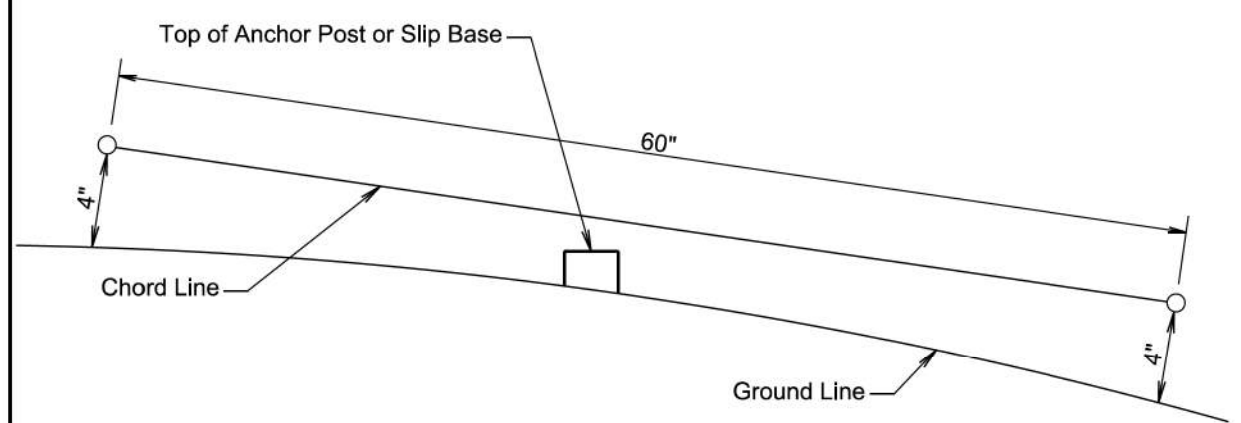

**ELEVATION VIEW**

**GENERAL NOTES:**

The top of anchor posts and slip bases WILL NOT extend above a 60" chord line within a 120" diameter circle around the post with ends 4" above the ground.

At locations where there is curb and gutter adjacent to the breakaway sign support, the stub height will be a maximum of 4" above the ground line at the localized area adjacent to the breakaway support stub.

January 22, 2021

Published Date: 2026	SD DOT	BREAKAWAY SUPPORT STUB CLEARANCE	PLATE NUMBER 632.18
			Sheet 1 of 1

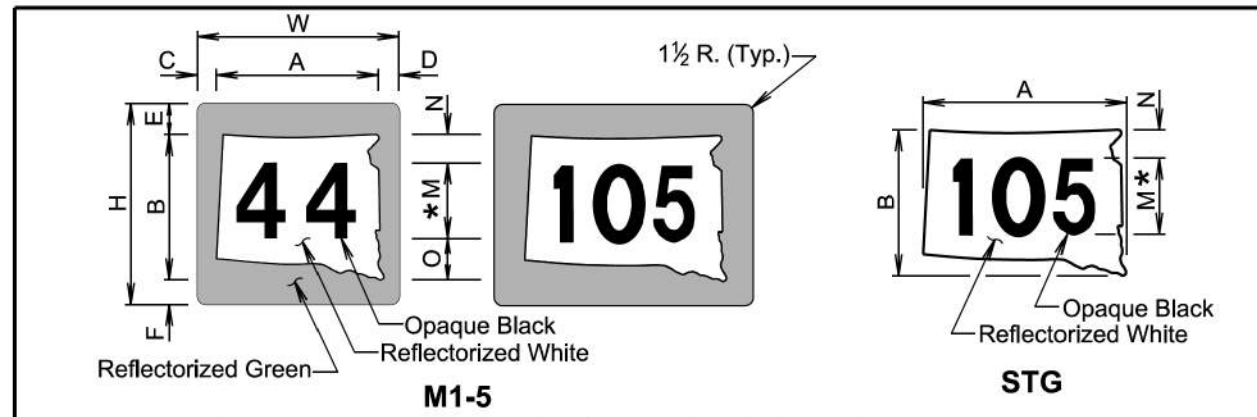

**M1-5**

SIGN CODE	WxH	A	B	C	D	E	F	M*	N	O
M1-5	24x24	20 1/2	18	2	1 1/2	3 1/2	2 1/2	12D	2	4
M1-5 **	30x24	24	18	2 1/4	1 3/4	3 1/2	2 1/2	12D	2	4
M1-5	30x30	25 5/8	22 1/2	2 1/2	1 7/8	4 3/8	3 3/8	15D	2 1/2	5
M1-5	36x36	30 3/4	27	3	2 1/4	5 1/4	3 3/4	18D	3	6

**STG**

SIGN CODE	AxB	M*	N
STG-24	24x18	10D	4
STG-32	32x24	12D	4 3/4
STG-48	48x36	18D	7
STG-64	64x48	24D	9 1/2

\* In the few cases where there is not enough space for the numerals, the standard D series font may be replaced with C series font if approved by the Engineer.

\*\* 3 Digits

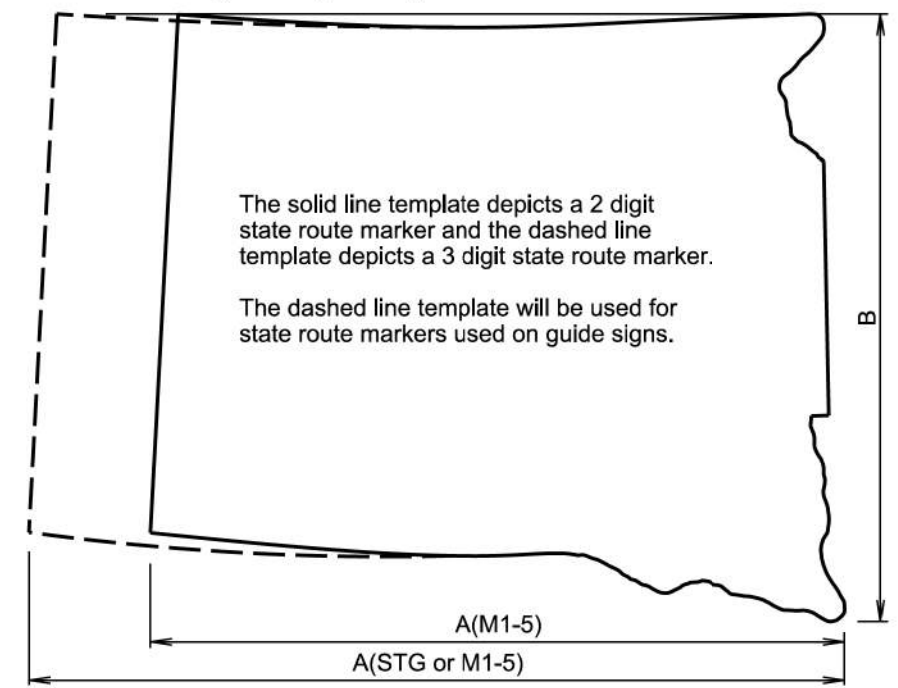

**TEMPLATE FOR STATE ROUTE MARKER**

**GENERAL NOTES:**

The unit for all dimensions shown is inches.

Numerals will be D series font for all state route markers except as noted above.

December 23, 2019

Published Date: 2026	SD DOT	STATE ROUTE MARKERS	PLATE NUMBER 632.20
			Sheet 1 of 1

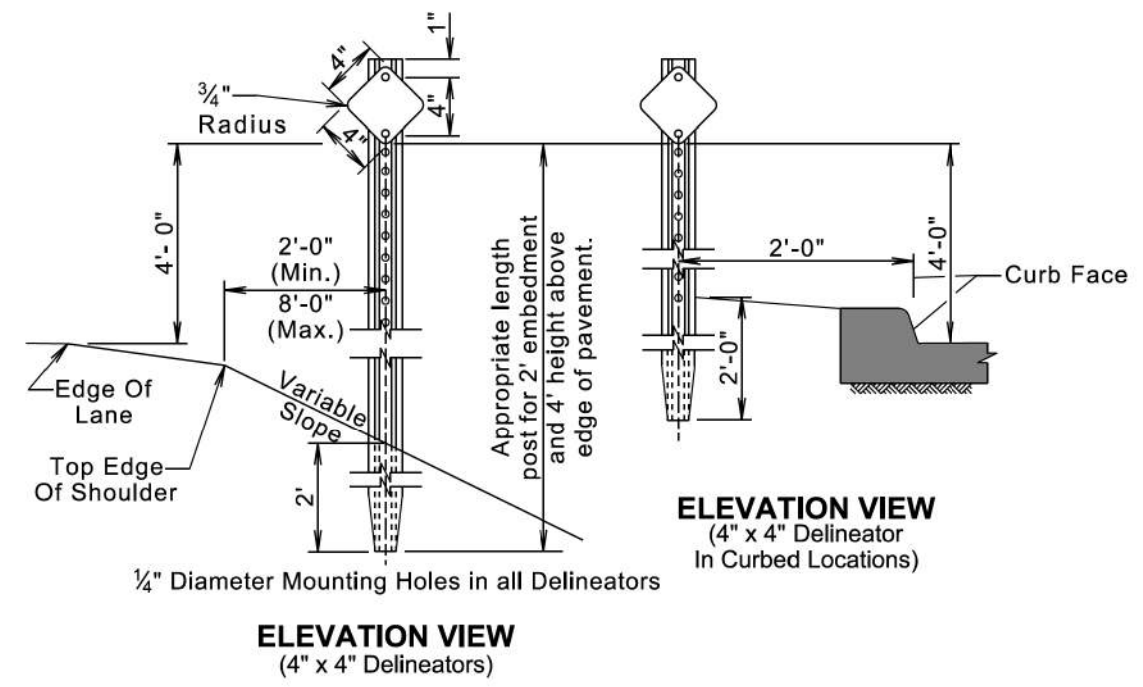
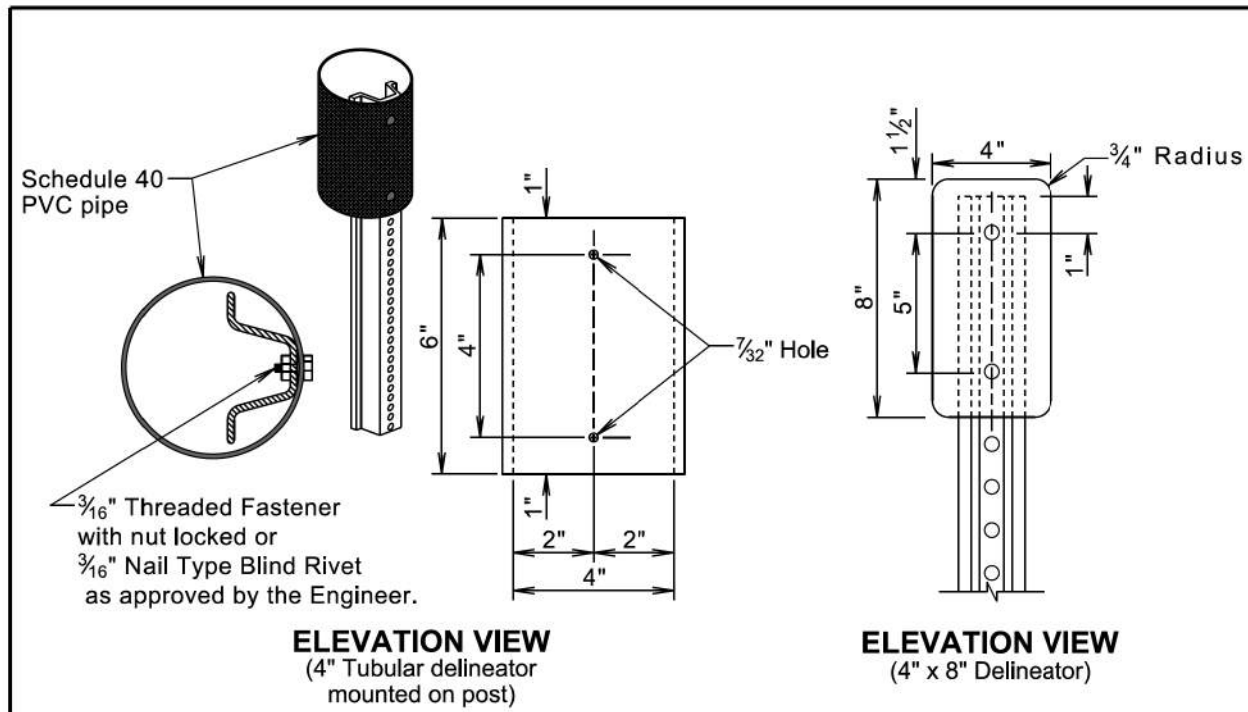

**GENERAL NOTES:**  
Back-to-back delineation is required for two-way traffic, single-sided delineation for one-way traffic.

March 31, 2024

Published Date: 2026	SD DOT	DELINEATOR INSTALLATION DETAIL	PLATE NUMBER 632.42
			Sheet 1 of 1

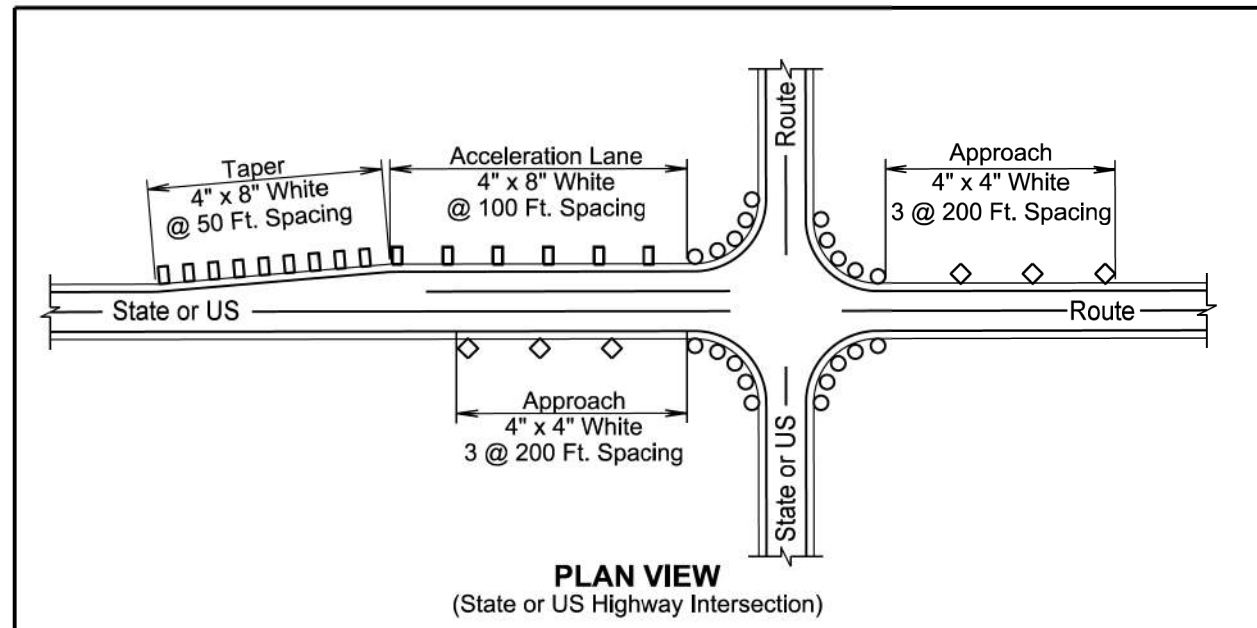

LEGEND	
◇	4" x 4" White Delineator
□	4" x 8" White Delineator
○	4" x 6" White Tubular Delineator

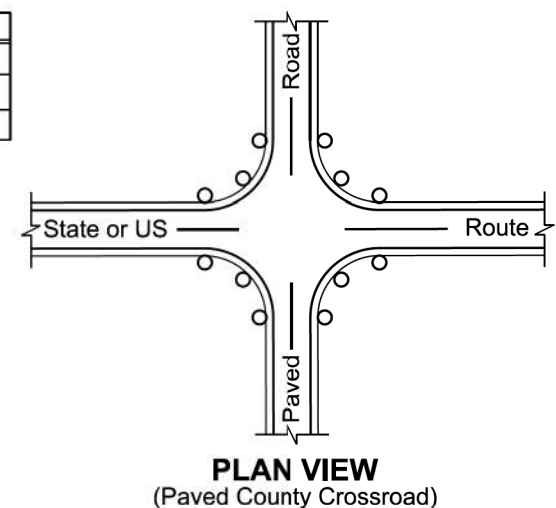

**GENERAL NOTES:**

At all intersections with State or US highways and paved county roads:

For radii greater than 100 feet, place 5 tubular white delineators on equally spaced posts around the turning radius.

For radii greater than 50 feet up to 100 feet, place 4 tubular white delineators on equally spaced posts around the turning radius.

For radii of 50 feet or less, place 3 tubular white delineators on equally spaced posts around the turning radius.

November 19, 2020

Published Date: 2026	SD DOT	DELINEATOR AT INTERSECTIONS	PLATE NUMBER 632.44
			Sheet 1 of 1

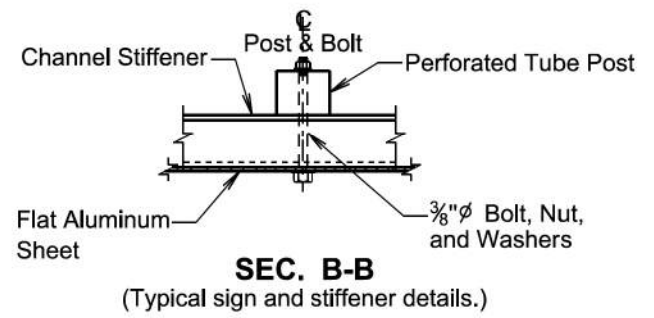
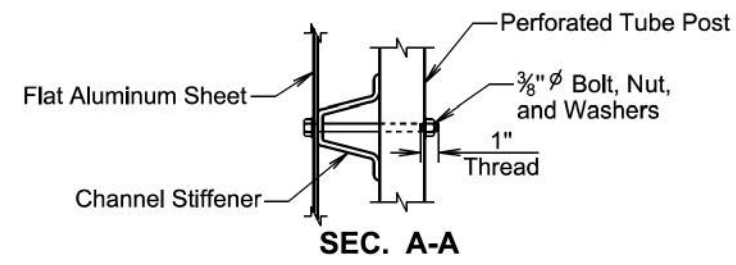
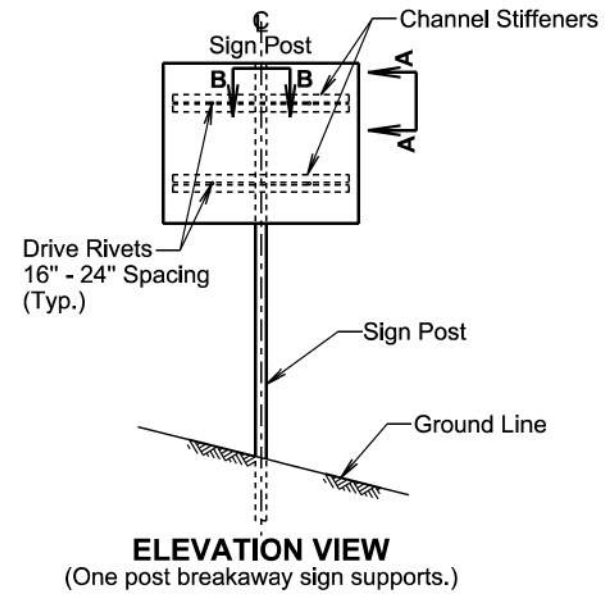

∅ A plastic washer, as recommended by the sheeting manufacturer, will be installed between the sign face and the metal washer shown.

November 19, 2020

Published Date: 2026	SD DOT	SIGN STIFFENER DETAILS	PLATE NUMBER 632.60
			Sheet 1 of 2

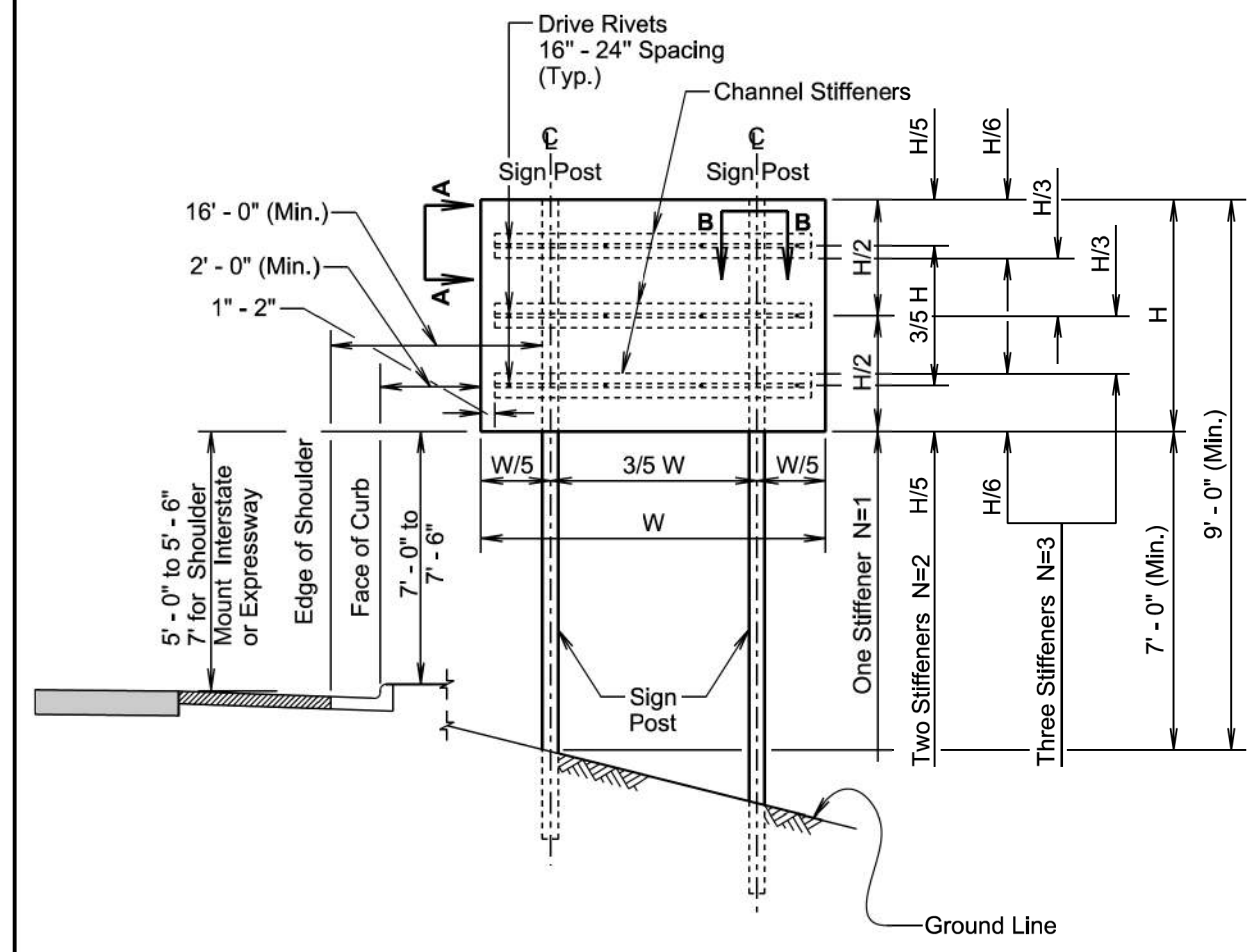

**GENERAL NOTES:**

The number of stiffeners used (N) will be as follows:  
 If  $H \leq 2' - 0''$  then  $N = 1$   
 if  $2' - 0'' < H \leq 8' - 0''$  then  $N = 2$   
 if  $8' - 0'' < H \leq 15' - 0''$  then  $N = 3$   
 where H is the vertical dimension of the sign.

A minimum of two bolts will be required to fasten the sign to each post.

November 19, 2020

Published Date: 2026	SD DOT	SIGN STIFFENER DETAILS	PLATE NUMBER 632.60
			Sheet 2 of 2

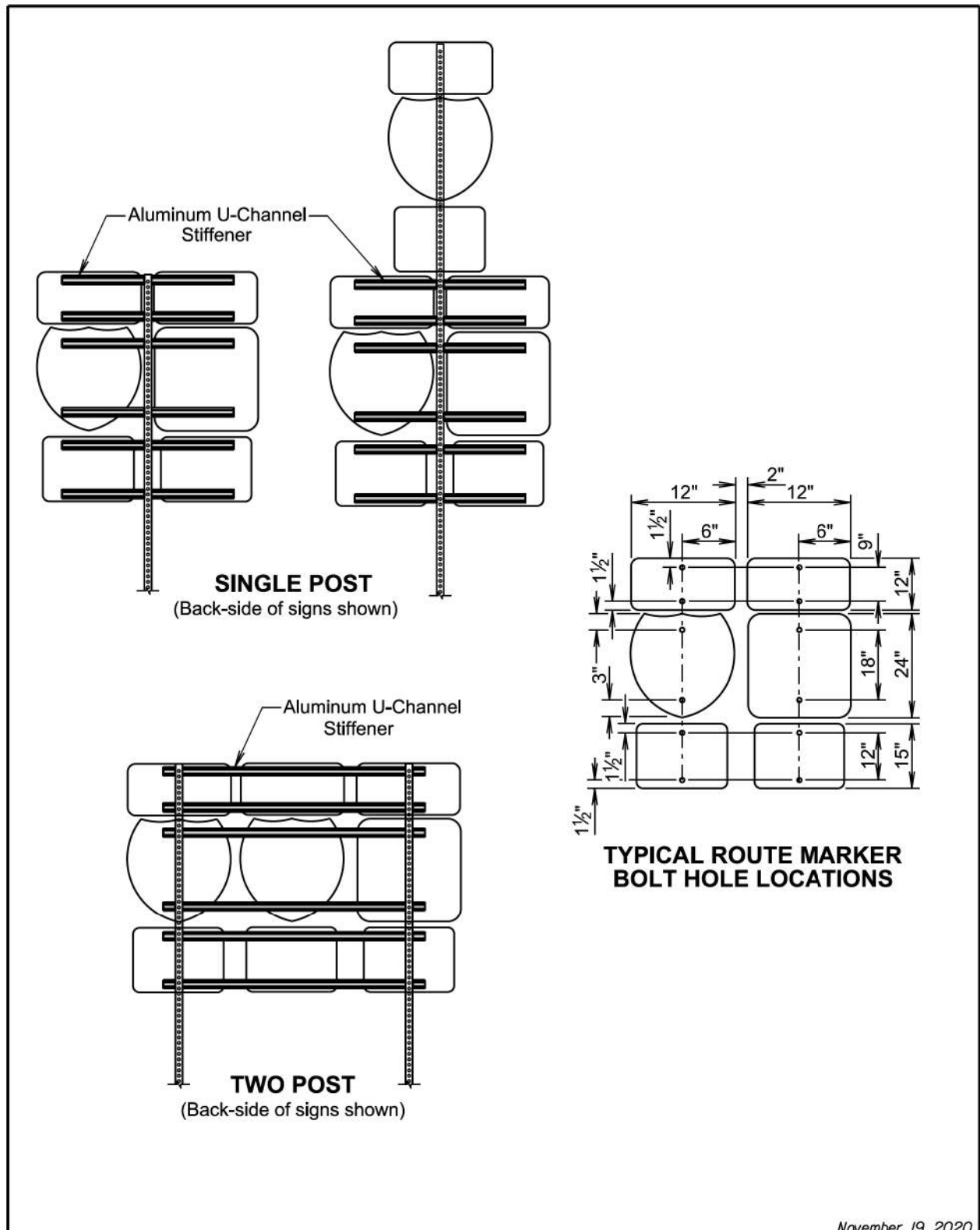

Published Date: 2026	SD DOT	MULTIPLE ROUTE MARKER SIGN STIFFENER INSTALLATION DETAILS	November 19, 2020
			PLATE NUMBER 632.62
			Sheet 1 of 1

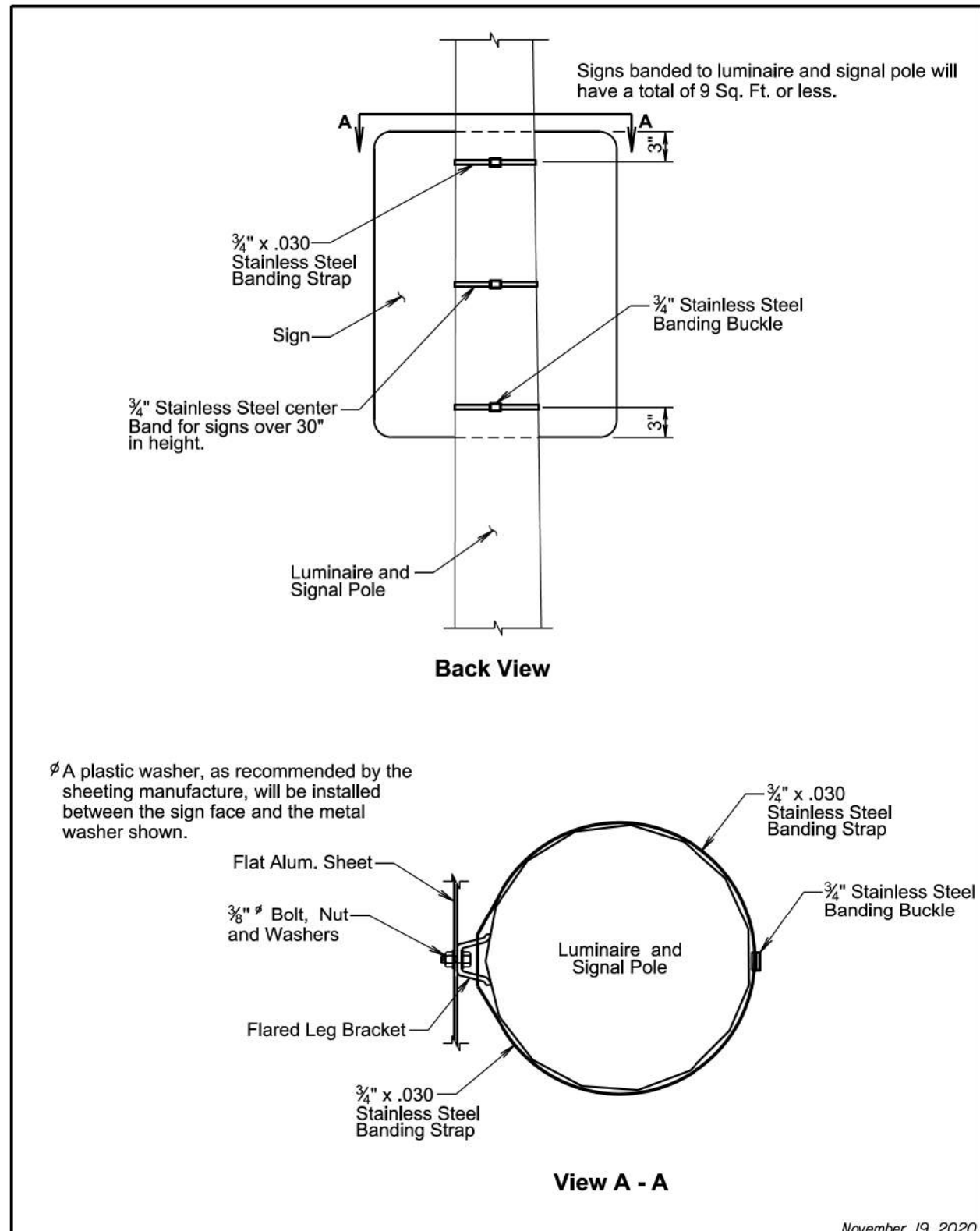

Published Date: 2026	SD DOT	BANDING SIGN TO LUMINAIRE AND SIGNAL POLE	November 19, 2020
			PLATE NUMBER 632.80
			Sheet 1 of 1

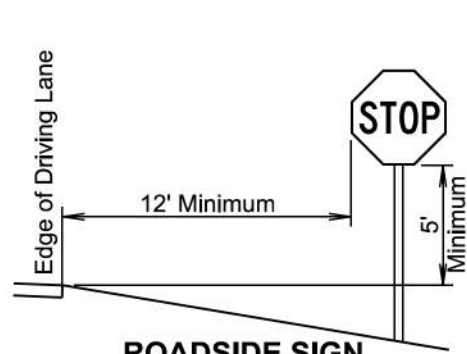

**ROADSIDE SIGN  
IN RURAL AREA**

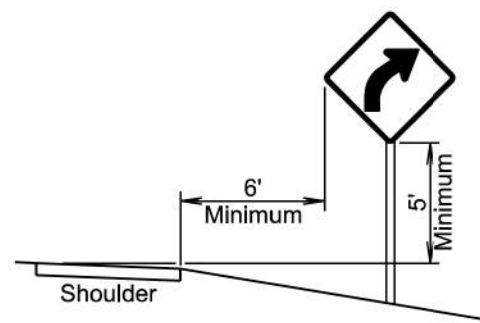

**ROADSIDE SIGN  
IN RURAL AREA**  
(If shoulder width is greater than 6 foot)

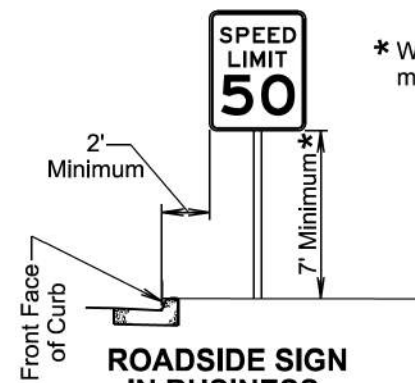

**ROADSIDE SIGN  
IN BUSINESS,  
COMMERCIAL, OR  
RESIDENTIAL AREA**

\* Where parking or pedestrian movements are likely to occur.

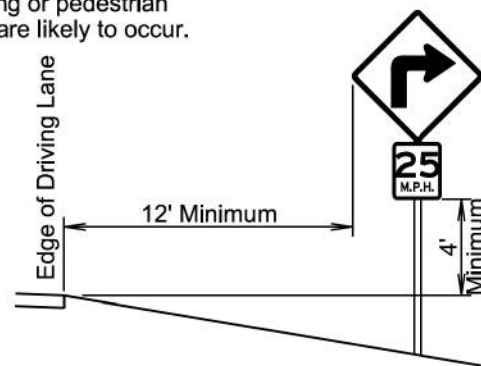

**WARNING SIGN ADVISORY  
SPEED PLAQUE IN RURAL AREA**

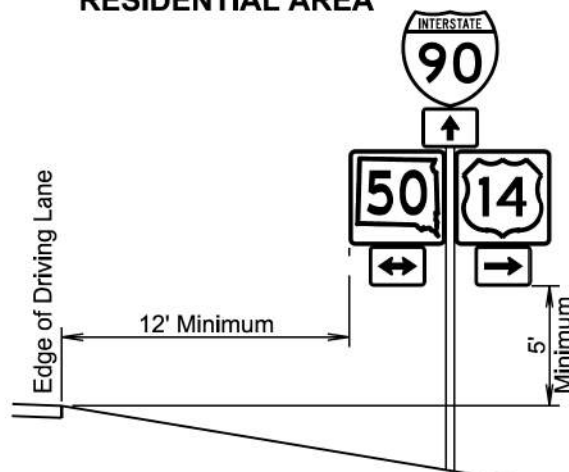

**ROADSIDE SIGN  
IN RURAL AREA**

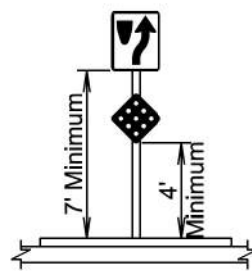

**SIGN ON NOSE  
OF MEDIAN**

April 8, 2025

<b>Published Date: 2026</b>	<b>SD DOT</b>	<b>OFFSETS FOR SIGN INSTALLATION</b>	PLATE NUMBER 632.90
			Sheet 1 of 1