

FOR BIDDING PURPOSES ONLY

PROJECT	SHEET	TOTAL SHEETS
P TAPU(47)	1	112

STATE OF SOUTH DAKOTA
DEPARTMENT OF TRANSPORTATION
PLANS FOR PROPOSED
PROJECT P TAPU(47)
PENNINGTON COUNTY
GRADING, SIDEWALK, PIPE CULVERTS
PCN 09QH

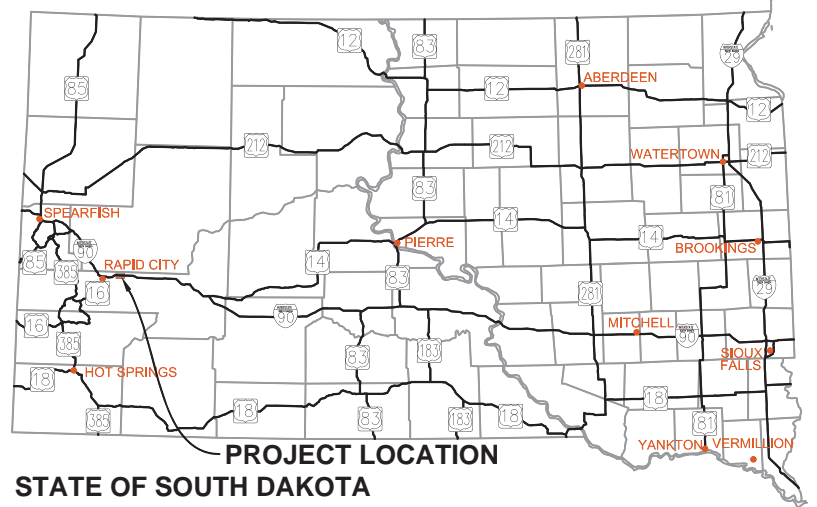

INDEX OF SHEETS

1	COVER SHEET
2	SUMMARY OF QUANTITIES
3-15	GENERAL NOTES
16	TYPICAL SECTIONS
17-18	TRAFFIC CONTROL
19-23	EROSION & SEDIMENT CONTROL
24-25	HORIZONTAL ALIGNMENT & SURVEY CONTROL
26	LEGEND & ABBREVIATIONS
27-34	SIDEWALK PLAN & PROFILE
35-37	RIGHT-OF-WAY LAYOUT
38-42	REMOVAL PLAN
43-46	ADA CURB RAMP LAYOUT
47-49	PERMANENT MARKING & SIGNING
50-65	DETAILS
66-112	CROSS SECTIONS

STATE OF SOUTH DAKOTA

BOX ELDER, SOUTH DAKOTA

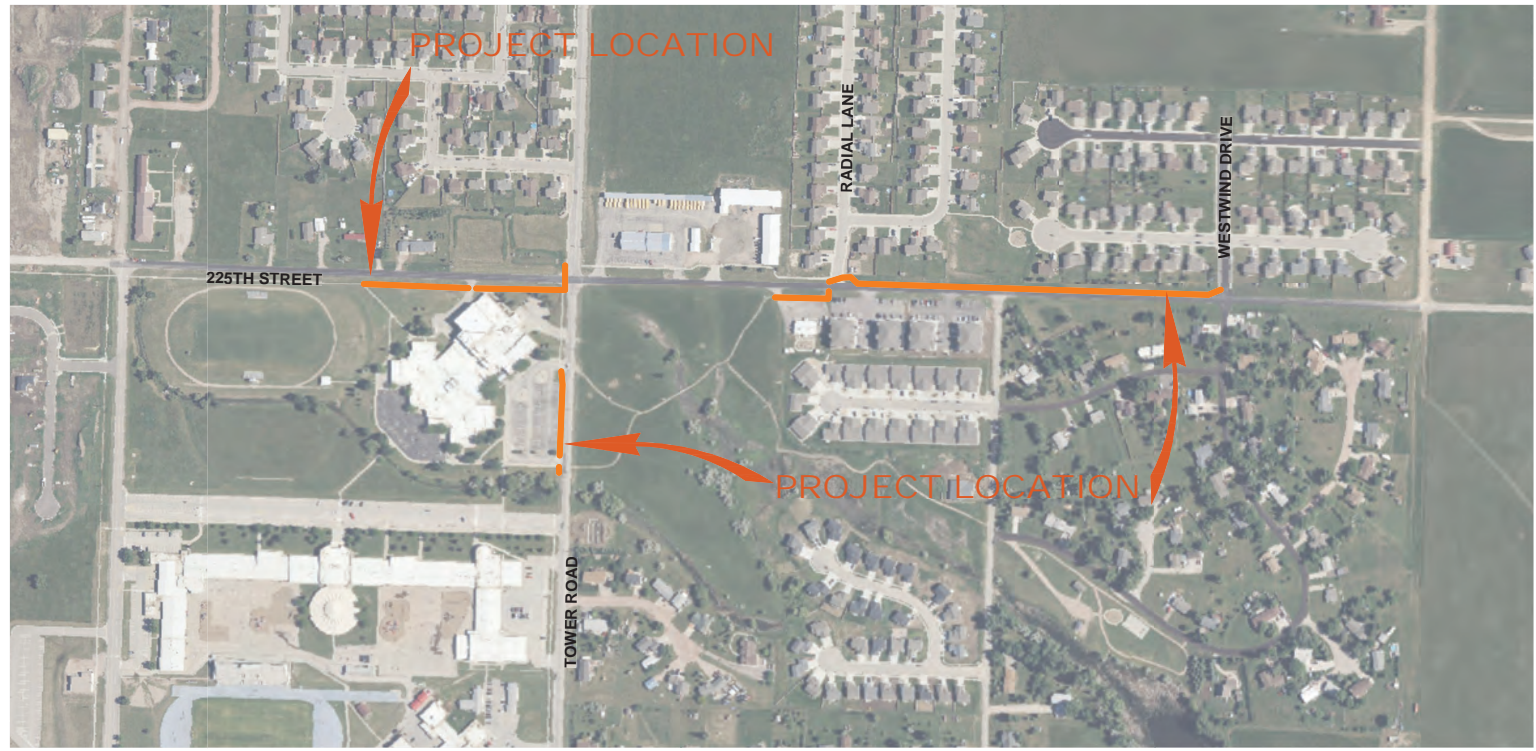

CERTIFICATION

I HEREBY CERTIFY THAT THE ATTACHED PLANS WERE PREPARED BY ME OR UNDER MY DIRECT SUPERVISION AND THAT I AM A DULY REGISTERED PROFESSIONAL ENGINEER IN THE STATE OF SOUTH DAKOTA.



DATE: _____

VICINITY MAP

NO SCALE

GROSS LENGTH	2372 FEET	0.45 MILES
LENGTH OF EXCEPTIONS	0 FEET	0 MILES
NET LENGTH	2372 FEET	0.45 MILES

STORM WATER PERMIT

MAJOR RECEIVING BODY OF WATER: BOX ELDER CREEK
AREA DISTURBED: 0.53 ACRES
TOTAL PROJECT AREA: 0.53 ACRES
APPROX. BEGIN LAT LONG: 44.1384, -103.0606



CITY OF BOX ELDER
420 VILLA DR
BOX ELDER, SD 57719
PH: 605.923.1404
Scott.Lange@boxelder.us

809 DEADWOOD AVE, STE. 2
RAPID CITY, SD 57701
PH: 605-872-5012



1

June 3, 2026

ESTIMATE OF QUANTITIES AND ENVIRONMENTAL COMMITMENTS

FOR BIDDING PURPOSES ONLY

SD DOT	PROJECT	SHEET	TOTAL SHEETS
	P TAPU(47)	2	112

Non-Section Method

BID ITEM NUMBER	ITEM	QUANTITY	UNIT
009E0010	Mobilization	Lump Sum	LS
009E4100	Construction Schedule, Category I	Lump Sum	LS
100E0100	Clearing	Lump Sum	LS
110E0300	Remove Concrete Curb and/or Gutter	153	Ft
110E0500	Remove Pipe Culvert	10	Ft
110E1010	Remove Asphalt Concrete Pavement	16.0	SqYd
110E1100	Remove Concrete Pavement	19.0	SqYd
110E1140	Remove Concrete Sidewalk	84.0	SqYd
110E1640	Remove Granular Material	2.0	CuYd
110E7150	Remove Sign for Reset	6	Each
110E7510	Remove Pipe End Section for Reset	2	Each
120E0010	Unclassified Excavation	398	CuYd
120E0600	Contractor Furnished Borrow	90	CuYd
120E2000	Undercutting	277	CuYd
230E0010	Placing Topsoil	135	CuYd
260E1010	Base Course	14.0	Ton
260E2010	Gravel Cushion	277.0	Ton
380E3025	6" Reinforced PCC Driveway Pavement	18.0	SqYd
380E4010	6" PCC Fillet Section	19.0	SqYd
450E0122	18" RCP Class 2, Furnish	28	Ft
450E0130	18" RCP, Install	28	Ft
450E2008	18" RCP Flared End, Furnish	1	Each
450E2009	18" RCP Flared End, Install	1	Each
450E4759	18" CMP 16 Gauge, Furnish	60	Ft
450E4760	18" CMP, Install	60	Ft
450E5211	18" CMP Flared End, Furnish	6	Each
450E5212	18" CMP Flared End, Install	6	Each
450E9001	Reset Pipe End Section	2	Each
451E0522	12" PVC Pipe	21	Ft
451E6080	Adjust Water Valve Box	9	Each
632E1320	2.0"x2.0" Perforated Tube Post	56.0	Ft
632E3205	Flat Aluminum Sign, Nonremovable Copy Super/Very High Intensity	36.0	SqFt
632E3500	Reset Sign	7	Each
633E3030	Durable Pavement Marking, 24" White	187	Ft
633E3065	Durable Pavement Marking, Symbol	16	Each
633E5051	Surface Preparation for Pavement Marking	390	SqFt
634E0110	Traffic Control Signs	272.0	SqFt
634E0120	Traffic Control, Miscellaneous	Lump Sum	LS
635E5980	Rectangular Rapid Flashing Beacon System	2	Each
650E0080	Type B68 Concrete Curb and Gutter	233	Ft
651E0040	4" Concrete Sidewalk	14,977	SqFt
651E7000	Type 1 Detectable Warnings	227	SqFt

Non-Section Method

BID ITEM NUMBER	ITEM	QUANTITY	UNIT
671E1048	48" Manhole	1	Each
671E6008	Type A8 Manhole Frame and Lid	1	Each
671E7020	Connect Into Existing Manhole	1	Each
730E0206	Type D Permanent Seed Mixture	56	Lb
731E0100	Fertilizing	271	Lb
732E0250	Fiber Mulching	553	Lb
734E0151	9" Diameter Erosion Control Wattle	25	Ft
900E1350	Temporary Surfacing	100.0	SqFt
900E5520	12" Area Drain with Grate Assembly	1	Each



ENVIRONMENTAL COMMITMENTS

The SDDOT is committed to protecting the environment and uses Environmental Commitments as a communication tool for the Engineer and Contractor to ensure that attention is given to avoid, minimize, and/or mitigate an environmental impact. Environmental commitments to various agencies and the public have been made to secure approval of this project. An agency with permitting authority can delay a project if identified environmental impacts have not been adequately addressed. Unless otherwise designated, the Contractor's primary contact regarding matters associated with these commitments will be the Project Engineer. During construction, the Project Engineer will verify that the Contractor has met Environmental Commitment requirements. These environmental commitments are not subject to change without prior written approval from the SDDOT Environmental Office.

Additional guidance on SDDOT's Environmental Commitments can be accessed through the Environmental Procedures Manual found at: <https://dot.sd.gov/media/documents/EnvironmentalProceduresManual.pdf>

For questions regarding change orders in the field that may have an effect on an Environmental Commitment, the Project Engineer will contact the Environmental Engineer at 605-773-3180 or 605-773-4336 to determine whether an environmental analysis and/or resource agency coordination is necessary.

Once construction is complete, the Project Engineer will review all environmental commitments for the project and document their completion.

COMMITMENT E: STORM WATER

Construction activities constitute less than 1 acre of disturbance.

Action Taken/Required:

At a minimum and regardless of project size, appropriate erosion and sediment control measures must be installed to control the discharge of pollutants from the construction site.

COMMITMENT H: WASTE DISPOSAL SITE

The Contractor will furnish a site(s) for the disposal of construction and/or demolition debris generated by this project.

Action Taken/Required:

Construction and/or demolition debris may not be disposed of within the Public ROW.

The waste disposal site(s) will be managed and reclaimed in accordance with the following from the General Permit for Construction/Demolition Debris Disposal Under the South Dakota Waste Management Program issued by the Department of Agriculture and Natural Resources.

The waste disposal site(s) will not be located in a wetland, within 200 feet of surface water, or in an area that adversely affects wildlife, recreation,

aesthetic value of an area, or any threatened or endangered species, as approved by the Environmental Office and the Project Engineer.

If the waste disposal site(s) is located such that it is within view of any ROW, the following additional requirements will apply:

1. Construction and/or demolition debris consisting of concrete, asphalt concrete, or other similar materials will be buried in a trench separate from wood debris. The final cover over the construction and/or demolition debris will consist of a minimum of 1 foot of soil capable of supporting vegetation. Waste disposal sites provided outside of the Public ROW will be seeded in accordance with Natural Resources Conservation Service recommendations. The seeding recommendations may be obtained through the appropriate County NRCS Office. The Contractor will control the access to waste disposal sites not within the Public ROW with fences, gates, and placement of a sign or signs at the entrance to the site stating, "No Dumping Allowed".

2. Concrete and asphalt concrete debris may be stockpiled within view of the ROW for a period not to exceed the duration of the project. Prior to project completion, the waste will be removed from view of the ROW or buried, and the waste disposal site reclaimed as noted above.

The above requirements will not apply to waste disposal sites that are covered by an individual solid waste permit as specified in SDCL 34A-6-58, SDCL 34A-6-1.13, and ARSD 74:27:10:06. Failure to comply with the requirements stated above may result in civil penalties in accordance with South Dakota Solid Waste Law, SDCL 34A-6-1.31.

All costs associated with furnishing waste disposal site(s), disposing of waste, maintaining control of access (fence, gates, and signs), and reclamation of the waste disposal site(s) will be incidental to the various contract items.

COMMITMENT I: HISTORIC PRESERVATION OFFICE CLEARANCES

The SDDOT has obtained concurrence with the State Historic Preservation Office (SHPO or THPO) for all work included within the project limits and all department designated sources and designated option material sources, stockpile sites, storage areas, and waste sites provided within the plans.

Action Taken/Required:

All earth disturbing activities not designated within the plans require a cultural resource review prior to scheduling the pre-construction meeting. This work includes but is not limited to: Contractor furnished material sources, material processing sites, stockpile sites, storage areas, plant sites, and waste areas. The Contractor will arrange and pay for a record search and when necessary, a cultural resource survey. The Contractor has the option to contact the state Archaeological Research Center (ARC) at 605-394-1936 or another qualified archaeologist, to obtain either a records search or a cultural resources survey. A record search might be sufficient for review if the site was previously surveyed; however, a cultural resources survey may need to be conducted by a qualified archaeologist.

The Contractor will provide ARC with the following: a topographical map or aerial view in which the site is clearly outlined, site dimensions, project number, and PCN. If applicable, provide evidence that the site has been previously

disturbed by farming, mining, or construction activities with a landowner statement that artifacts have not been found on the site.

The Contractor will submit the cultural resources survey report to SDDOT Environmental Office, 700 East Broadway Avenue, Pierre, SD 57501-2586. SDDOT will submit the information to the appropriate SHPO/THPO. Allow **30 Days** from the date this information is submitted to the Environmental Engineer for SHPO/THPO review.

In the event of an inadvertent discovery of human remains, funerary objects, or if evidence of cultural resources is identified during project construction activities, then such activities within 150 feet of the inadvertent discovery will immediately cease and the Project Engineer will be immediately notified. The Project Engineer will contact the SDDOT Environmental Office, who will contact the appropriate SHPO/THPO within 48 hours of the discovery to determine an appropriate course of action.

SHPO/THPO review does not relieve the Contractor of the responsibility for obtaining any additional permits and clearances for Contractor furnished material sources, material processing sites, stockpile sites, storage areas, plant sites, and waste areas that affect wetlands, threatened and endangered species, or waterways. The Contractor will not utilize a site known or suspected of having contaminated soil or water. The Contractor will provide the required permits and clearances to the Project Engineer at the preconstruction meeting.



SEQUENCE OF OPERATIONS

The Contractor will submit a sequence of operations for approval two weeks prior to the preconstruction meeting. If changes to the sequence of operations are proposed during the project, these must be submitted for review a minimum of one week prior to potential implementation. Approval for changes to the sequence of operations will only be allowed when the proposed changes meet with the Department's intent for traffic control and sequencing of the work.

UTILITIES

The Contractor will contact the involved utility companies through South Dakota One Call (1-800-781-7474) prior to starting work. It will be the responsibility of the Contractor to coordinate work with the utility owners to avoid damage to existing facilities.

The Contractor will be aware that the existing utilities shown in the plans were surveyed prior to the design of this project and might have been relocated or replaced by a new utility facility prior to construction of this project, might be relocated or replaced by a new utility facility during the construction of this project, or might not require adjustment and may remain in its current location. The Contractor will contact each utility owner and confirm the status of all existing and new utility facilities. The utility contact information is provided elsewhere in the plans or bidding documents.

PROCEDURES FOR DETERMINING UNCLASSIFIED EXCAVATION AND UNDERCUTTING QUANTITY

Unclassified Excavation and Undercutting will not be measured for payment but will be paid for as plan quantity.

Unclassified Excavation will include all excavation, embankment and shaping required for the sidewalk installation.

In all cut sections the earthen subgrade will be undercut 0.5 foot below the earthen subgrade surface. The undercut material or other suitable material, as directed by the Engineer, will then be replaced and compacted to the density specified for the section being constructed.

SHRINKAGE FACTOR: Embankment +25%

TABLE OF UNCLASSIFIED EXCAVATION

	Quantity (CuYd)
Excavation	96
Undercut	277
Topsoil	135
Total	508

TABLE OF UNDERCUTTING QUANTITIES URBAN

Station	to	Station	Description	Quantity (CuYd)
10+25		13+50	225th St	36
13+75		16+45	225th St	38
20+10		20+20	225th St	1
20+45		22+10	225th St	15
22+40		22+60	225th St	2
22+90		23+50	225th St	13
23+50		27+00	225th St	39
27+00		30+50	225th St	39
30+50		34+00	225th St	39
34+00		34+73	225th St	10
40+00		40+20	Tower Rd	2
40+50		43+13	Tower Rd	44
Total:				277

REMOVE ASPHALT CONCRETE PAVEMENT

An estimated 16 Square Yards of the in-place asphalt concrete surfacing will be removed from the existing roadway according to the proposed surfacing typical sections and wasted as directed by the Engineer. Care will be taken not to waste the in-place granular material. The remaining in-place granular material will be salvaged and stockpiled.

The quantity of asphalt removed material is estimated from the in-place surfacing typical sections. This estimated quantity is not included in the unclassified excavation quantities.

TABLE OF ASPHALT CONCRETE PAVEMENT REMOVAL

Station	to	Station	L/R	Quantity (SqYd)
34+70		35+10	R	7
40+05		40+13	R	9
Total:				16

TABLE OF SIDEWALK REMOVAL

Station	to	Station	L/R	Quantity (SqYd)
16+48		17+10	L	32
22+50		22+90	L	19
34+83		35+10	R	8
40+07		40+15	R	10
43+30		43+42	R	15
Total:				84

TABLE OF CONCRETE CURB AND/OR GUTTER REMOVAL

Station	to	Station	L/R	Quantity (Ft)
13+53		13+63	4L-6R	20
16+40		16+65	51L-82L	71
17+10		17+10	80L-86L	6
22+70		22+90	5L	10
34+73		35+05	7L	14
40+06		40+12	10R	12
43+15		43+30	3L-7R	20
Total:				153



TABLE FOR ADJUSTMENT OF WATER VALVES

Station	Adjustment
12+28	4"
12+93	20"
22+04	4"
22+50	4"
22+52	4"
22+53	4"
27+80	6"
42+25	4"
42+45	4"

INTERSECTING ROADS AND ENTRANCES

In areas where granular material has been placed adjacent to the existing asphalt concrete, the Contractor will be required to remove the granular material to a depth below the existing asphalt concrete to allow for the placement of the new asphalt concrete. New asphalt concrete will be placed flush with the existing asphalt concrete. The existing granular material removed will be placed on the entrances, intersecting roads or other locations as directed by the Engineer.

All costs to remove and place the granular material including labor, equipment and incidentals will be incidental to the various related contract items.

CORRUGATED METAL PIPE

Corrugated metal pipes will have 2 3/8-inch x 1/2-inch corrugations for 42-inch and smaller round pipe and 48-inch and smaller arch pipe unless otherwise stated in the plans. Corrugated metal pipes will have 3-inch x 1-inch or 5-inch x 1-inch corrugations for 48-inch and larger round pipe and 54-inch and larger arch pipe unless otherwise stated in the plans.

PIPE COVER

The earthen subgrade cover for some pipe installations is less than one foot. The Contractor will take the necessary precautions to ensure the structural properties of the pipes are not damaged after installation and prior to the placement of final surfacing. Any additional costs for preventing damage to these pipes will be incidental to the contract unit price per foot for the corresponding pipe installation contract item.

CONTRACTOR FURNISHED BORROW EXCAVATION

The Contractor will provide a suitable site for Contractor furnished borrow excavation material. The Contractor is responsible for obtaining all required permits and clearances for the borrow site. The borrow material will be approved by the Engineer. The plans quantity for "Contractor Furnished Borrow Excavation" as shown in the Estimate of Quantities will be the basis of payment for this item.

Restoration of the Contractor furnished borrow excavation site will be the responsibility of the Contractor.

MAINTAIN DRIVEWAY ACCESS

The Contractor shall be responsible for providing access to all adjacent properties during construction. Temporary roadway and access closure is anticipated. The contractor shall coordinate with the adjacent property owners to meet their requirements for access to their properties. Final details and locations of access points and construction procedures shall be approved by the Engineer prior to the start of the work.

Gravel or other material approved by the Engineer shall be used for maintaining driveway accesses during construction. The temporary surfacing shall consist of approximately 4 inches of surfacing material with the top surface constructed to tie into the existing roadway surfaces. Compaction of the gravel shall be to the satisfaction of the Engineer. Cost for furnishing, hauling, placing, compacting, maintaining, removing, and disposing of the temporary surfacing materials shall be included in the contract unit price for "Temporary Surfacing"

WATER FOR COMPACTION

The cost of water for compaction of the granular material will be incidental to the various other contract items. A minimum of 4% moisture will be required at the time of compaction unless otherwise directed by the Engineer.

CONCRETE SIDEWALK

The concrete sidewalk will be constructed in accordance with Section 651.

Due to the extra depth required, the granular cushion material required, as per the typical sections, will be paid for separately at the contract unit price per ton for Gravel Cushion. The gravel cushion will meet the requirements of Section 882. Compaction will be to the satisfaction of the Engineer.

TABLE OF 4" CONCRETE SIDEWALK

Station	to	Station	L/R	Quantity (SqFt)
10+25		13+50	L	1,961
13+75		16+45	L	2,027
20+10		20+20	L	50
20+45		22+10	L	825
22+40		22+60	R	100
22+90		23+50	R	727
23+50		27+00	R	2,100
27+00		30+50	R	2,100
30+50		34+00	R	2,100
34+00		34+73	R	521
40+00		40+20	R	100
40+50		43+13	R	2,366

Total: 14,977

TABLE OF 6" REINFORCED CONCRETE DRIVEWAY

Station	to	Station	L/R	Quantity (SqFt)
20+20		20+45	L	18

Total: 18

TYPE 1 DETECTABLE WARNINGS

Detectable warnings will be in compliance with the Americans with Disabilities Act regulations.

The detectable warnings will be installed according to the manufacturer's installation instructions.



A concrete thickness equal to the adjacent concrete sidewalk thickness and 2 inches of granular cushion material will be placed below the Type 1 Detectable Warnings. When concrete is placed below the detectable warnings then the concrete thickness will be transitioned at the rate of 1" per foot to match the adjacent concrete sidewalk thickness.

The detectable warnings will be a brick red color for application in concrete curb ramps. Cast iron plates may be a natural patina (weathered steel).

Type 1 Detectable Warning Panels will be one of the following products: Type 1 Detectable Warnings

<u>Product</u>	<u>Manufacturer</u>
Detectable Warning Plate Cast Iron Plate	Neenah Foundry Company Neenah, WI 800-558-5075 http://www.neenahfoundry.com/
Detectable Warning Plate Cast Iron Plate	Deeter Foundry Lincoln, NE 800-234-7466 http://www.deeter.com/
Detectable Warning Plate Cast Iron Plate(No Coating)	East Jordan Iron Works, Inc. 301 Spring Street East Jordan, MI 49727 800-626-4653 http://www.ejiw.com
Iron Dome Cast Iron Detectable Warning Tile	ADA Solutions, Inc. 323 Andover Street Suite 3 Wilmington, MA 01887 800-372-0519 https://adatile.com
TufTile (wet-set) Cast Iron Replaceable Tile	TufTile 1200 Flex Court Lake Zurich, IL 60047 888-960-8897 http://www.tuftile.com/
Advantage Tactile Detectable Warning Cast Iron Plate	Advantage Tactile Systems, Inc. 241 Main Street, Suite 100 Buffalo, NY 14203 800-679-4022 https://advantagetactile.com/

TABLE OF TYPE 1 DETECTABLE WARNINGS

Station	L/R	Quantity (SqFt)
13+51.28	L	12
13+77.71	L	12
16+52.29	L	13
16+50.5	L	13
16+65.27	L	12
17+07.12	L	12
22+09.85	L	12
22+42.10	L	12
22+59.62	L	12
22+90.33	R	12
34+73.34	R	12
35+08.63	R	12
40+13.06	L/R	41
40+53.13	R	16
43+11.29	R	12
43+46.47	R	12
Total:		227

SURFACING THICKNESS DIMENSIONS

At those locations where material must be placed to achieve a required elevation, the depth/quantity may be varied to achieve the required elevation.

GENERAL TRAFFIC CONTROL

Existing guide, route, informational logo, regulatory, and warning signs will be temporarily reset and maintained during construction. Removing, relocating, covering, salvaging, and resetting of existing traffic control devices, including delineation, will be the responsibility of the Contractor. Cost for this work will be incidental to the contract unit prices for the various items unless otherwise specified in the plans. Any delineators and signs damaged or lost will be replaced by the Contractor at no cost to the State.

All temporary traffic control sign locations will be set in the field by the Contractor and verified by the Engineer prior to installation.

Portable sign supports will not be located on sidewalks, bicycle facilities, or other areas designated for pedestrian or bicycle traffic.

If there is a discrepancy between the traffic control plans, standard plates, and the MUTCD, whichever is more stringent will be used, as determined by the Engineer.

Unless otherwise stated in these plans, work will not be allowed during hours of darkness.

Fixed location signing placed more than 4 calendar days prior to the start of construction will be covered or laid down until the time of construction. The covers must be approved by the Engineer prior to installation. The cost of materials, labor, and equipment necessary to complete this work will be incidental to other contract items. No separate payment will be made.

All fixed location signs, sign posts, and breakaway bases will be removed within 7 calendar days following pavement marking.

All haul trucks will be equipped with an additional flashing amber light that is visible from the backside of the haul truck. The costs for the flashing amber lights will be incidental to the various related contract items.

At no time will a vertical drop-off of greater than 3 inches be left overnight adjacent to the traveled way. The Contractor will utilize embankment material to ensure a 3-inch vertical drop-off is not exceeded. The slope of the embankment material will not be steeper than a 4:1 within 30 feet of the traveled way.

Traffic will be maintained on the driving lanes. Use of the shoulder as a driving lane will not be permitted. Any damage to the shoulder due to rerouted traffic or Contractor's equipment will be repaired at no expense to the Department.

The Contractor will notify businesses/homeowners a minimum of two weeks prior to construction to inform them of upcoming construction and again a minimum of 48 hours prior to any blocked access to make appropriate arrangements.



LONGITUDINAL PEDESTRIAN BARRICADE

Longitudinal pedestrian barricades should not be used to provide positive protection for pedestrians.

To prevent any tripping hazard to pedestrians, ballast will be located behind or internal to the device.

When longitudinal pedestrian barricades are combined in a series, the maximum gap between devices that do not interlock will be one inch. Joints between devices that do interlock will be closed and flush to prevent canes or small wheels from being trapped and to facilitate safe hand trailing. When used as a sidewalk closure mechanism, longitudinal pedestrian barricade must run the entire width of the sidewalk. Longitudinal pedestrian barricade should provide a color contrasting pattern. Black should not be used to color any base on a device. The devices should comply with the general color and stripe pattern requirements of Section 6F.68 of the MUTCD.

Longitudinal pedestrian barricade will have continuous bottom and top surfaces. The top surface will be smooth to allow safe hand trailing. Both upper and lower surfaces will share a common vertical plane.

All costs will be incidental to the contract unit price per foot for "Longitudinal Pedestrian Barricade".

PEDESTRIAN CHANNELIZING DEVICE DETAILS

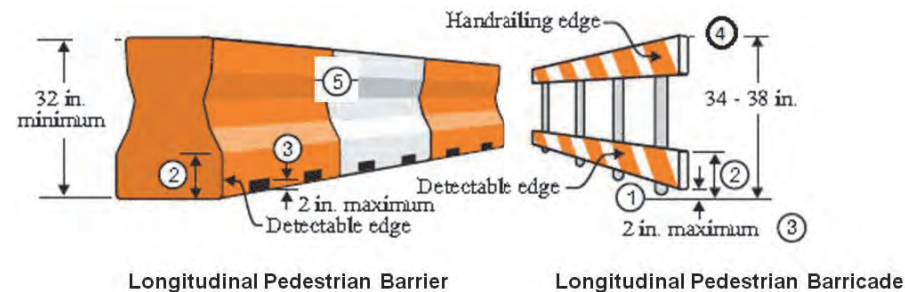

1. Barricade rail supports may not extend into the pedestrian walkway more than 4 inches from the face of the barricade.
2. The top edge of the bottom portion will be a minimum of 8 inches above the walkway.
3. Devices will not block water drainage from the walkway. A gap height or opening from the walkway surface up to a maximum of 2 inches in height is allowed for drainage purposes.
4. The top edge of the longitudinal pedestrian barricade is to be used as a guiderail to provide visual and tactile guidance to pedestrians along a designated route. The top surface should have a minimum width of 0.5 inches to allow the hand to feel the surface. The surface should be smooth and free of any sharp or abrasive elements to allow safe hand trailing.

Longitudinal pedestrian barrier used to provide positive protection from traffic to pedestrians should be crashworthy.

SURFACE PREPARATION FOR PAVEMENT MARKING

The Contractor will prepare the pavement surface prior to applying the durable pavement marking in accordance with the following.

In areas where the existing groove meets the required depth and existing markings are still in place, the Contractor will clean the existing groove without adding additional depth beyond the required depth for the new pavement marking, including reflective media as noted below.

Description	Specification	Tolerance
Depth of Groove	Marking Thickness ¹ + 15 mils	+ 5 mils

¹ Marking thickness will include the thickness of marking material and reflective media.

The cleaning will result in the existing pavement marking being adequately scuffed, abraded, and removed by light grinding or abrasive blasting or both to allow proper adhesion of the new durable pavement marking as per the manufacturer's recommendations to comply with product warranties.

Existing grooves not meeting the required depth will be re-grooved to the required depth for the new pavement marking, including reflective media. Equipment for grooving will be capable of the following:

- Grooving the total width of the groove in one pass or uniform depths with multiple passes.
- Grooving without causing damage to the pavement joints or joint sealant material.
- Provide uniform alignment and depth.
- Moving continuously to permit a mobile traffic work operation.

All costs associated with cleaning of the existing groove, including re-grooving, if needed, will be included in the contract unit price per sqft for "Surface Preparation for Pavement Marking". Surface preparation will be measured as 4" equivalent.

RECTANGULAR RAPID FLASHING BEACON SYSTEM

A Rectangular Rapid Flashing Beacon (RRFB) system will be in conformance with the current MUTCD and will consist of the following components:

- Individual RRFB displays as shown in the plans
- Accessible Pedestrian Signal push buttons as shown in the plans
- W11-2 (pedestrian crossing) signs as shown in the plans
- W16-7P (diagonal arrow) plaques as shown in the plans
- R10-25 (push button) signs as shown in the plans
- All necessary electronic programming and flash units, hardware, and wiring to make the system operational

One RRFB system is necessary for each pedestrian crossing location shown in the plans.

The programmed flash time will be as specified by the manufacturer. A small light directed at and visible to pedestrians in the crosswalk will be installed integral to the RRFB or push button, to give confirmation that each beacon is in operation.

All enclosures will be aluminum and comply with the requirements for NEMA 3R type.

All materials and installation costs necessary for the operation of each system will be incidental to the contract unit price per each for "Rectangular Rapid Flashing Beacon System".

DIGITALLY PRINTED SIGNS

Digitally printed signs will be allowed on this project. If the Contractor elects to provide digitally printed signs, such signs will adhere to the following specifications.

PROTECTIVE OVERLAY FILM

Permanent traffic signs printed with digital ink systems will be fabricated with a full sign protective overlay film designed to provide a smooth surface needed for retroreflectivity, and to protect the sign from fading and UV degradation. The overlaminates will comply with the retroreflective sheeting manufacturer's recommendations to ensure proper adhesion and transparency and will also meet the reflective film durability as identified in Table 1.

Table 1: Retroreflective Film Minimum Durability Requirements

ASTM D4956 Type	Full Sign Replacement Term (years)	Sheeting Replacement Term (years)
I	0	7
III	7	10
IV	7	10
VIII	7	10
IX	7	12
XI	7	12



FABRICATION

Retroreflective sheeting will be applied to a properly cleaned and prepared aluminum sign blank in accordance with the retroreflective sheeting manufacturer's recommendations. Sign legend will be applied using digital print technologies and systems in accordance with the retroreflective sheeting manufacturer's recommendations and the requirements of these plans.

Finished signs will be free of ragged edges and must be supplied clean and free of scratches, grease, oil, lubricants or other contaminants. Minor blemishes (dirt speck, dust, etc.) may settle on the fresh ink surface or become entrapped between the sheeting surface and transparent overlay film due to static charge within the sign shop environment. Any blemish must be minor and not interfere with the communication of the sign message to the motorist. The blemish must not be visible to the naked eye when viewed from 30 feet or greater.

After application of the retroreflective sheeting, sign blanks will be stacked and packaged face to face, back to back, and protected in accordance with the sheeting manufacturer's recommendations. Finished signs will be securely packaged to prevent damage during transit or storage according to the sheeting manufacturer's recommendations.

TRAFFIC SIGN PERFORMANCE WARRANTY PROVISIONS

Based on the ASTM Type of sheeting specified, traffic control signs will be warranted for the duration shown in Table 1. Full product terms and conditions are as established by each sheeting manufacturer and may contain certain limitations based on sheeting and ink colors, and geographic exposure of the sign. A copy of the warranty document with complete details of terms and conditions will be supplied if requested by the Engineer.

CERTIFIED DIGITAL SIGN FABRICATOR

Sign fabricators using digital imaging methods to produce regulated traffic signs must be certified by the reflective sheeting manufacturer whose materials are used to produce the delivered signs.

DATE TAGGING SIGNS WITH PERTINENT INFORMATION

All digitally printed signs are required to be date-tagged with the following 2 components:

1. Date tags on the back of signs

Tags will have the following information and be fabricated with material and printing system that are as durable as the warranted sign.

- Name of Sign Fabricator
- Date the sign was fabricated (month and year)
- Process that was used for sign fabrication (digitally printed)
- Supplier of sheeting that was used for fabricating the sign.

2. Border date

The month and year (mm/yyyy) of sign fabrication will be printed in the border of the sign in 3/8" sans serif font. Border date will be printed with the same warranted printed system as the sign face. The date should be printed in the locations indicated below.

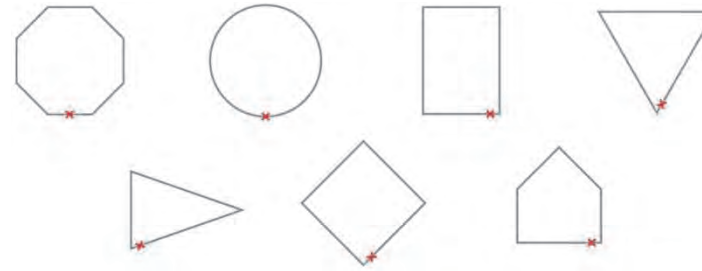
**SQUARE TUBE ANCHOR SLEEVE**

The Contractor will furnish and install new 2.5" x 2.5" x 18", 12 Gauge square tube anchor sleeve or equivalent components as approved by the Engineer for 2.0" x 2.0" perforated tube posts. A 2.25" x 2.25" x 4', 12 Gauge perforated tube post will be used as the anchor post for installation with the square tube anchor sleeve.

REMOVE SIGN FOR RESET AND RESET SIGN

Signs that are scheduled for reset will be dismantled and reassembled to the extent needed by the Contractor to properly reset the sign. Signs will be handled with care so that the existing signs, posts, and bases are not damaged during the relocation process. The Contractor will replace and pay for any reset signs damaged in their care. The Contractor will remove and dispose of any existing posts for all reset signs that require use of new posts as shown on the plan sheets.

All costs for removing, dismantling, and disposing of any existing posts will be incidental to the contract unit price per each for "Remove Sign for Reset". All costs for resetting the existing signs will be incidental to the contract unit price per each for "Reset Sign". All quantities for Remove Sign for Reset and Reset Sign will be per assembly at the contract unit price per each.

Irrigation System

If Contractor encounters irrigation systems during construction, lines shall be temporarily capped to not affect construction. During construction, the system shall be adjusted as necessary, resetting lines, reset sprinklers or add sprinklers to provide a similar or better system at the end of the project. This is Incidental to the Project.



MYCORRHIZAL INOCULUM

Mycorrhizal inoculum will consist of mycorrhizal fungi spores and mycorrhizal fungi-infected root fragments in a solid carrier. The carrier may include organic materials, calcinated clay, or other materials consistent with application and good plant growth. The supplier will provide certification of the fungal species claimed and the live propagule count. The inoculum will include a minimum 25% the fungal species *Rhizophagus intraradices*. The remaining 75% may include other endomycorrhizal fungal species.

All seed will be inoculated by the seed supplier with a minimum of 20,000 live propagules of mycorrhizal fungi per 1,000 square feet. All costs of inoculating the seed will be incidental to the contract unit price per pound for the corresponding permanent seed mixture.

The Mycorrhizal Inoculum provided will be from the approved product list. The approved product list may be viewed at the following internet site:

<http://apps.sd.gov/HC60ApprovedProducts/main.aspx>

FERTILIZING

Application of fertilizer will not be required on this project.

PERMANENT SEEDING

The areas to be seeded consist of all newly graded areas within the project limits except for the top of roadways and temporary easements under cultivation.

Lawn and turf seed, such as the Type D Permanent Seed Mixture, will be tested within 12 months prior to planting, exclusive of the calendar month in which the test was completed.

Type D Permanent Seed Mixture will consist of the following:

Grass Species	Variety	Pure Live Seed (PLS) (Pounds/1000 SqFt)
Kentucky Bluegrass	Avalanche, Appalachian, Wildhorse, Blue Bonnet, Action	1.4
Perennial Ryegrass	Turf Type Varieties	1.4
Creeping Red Fescue	Epic, Boreal, Chantilly	1.4
Chewings Fescue	Ambrose, K2, Zodiac, Shadow III	1.4
Alkali Grass	Fults, Fults II, Quill, Salty	1.4
Total:		7

PLACING TOPSOIL

The thickness will be approximately 4 inches within the right-of-way and 6 inches on temporary easements. Placing Topsoil will not be measured for payment but will be paid for as plan quantity.

FIBER MULCHING

Fiber mulch will be applied in a separate operation following permanent seeding.

An additional 2% by weight of tackifier will be added to the fiber mulch product selected from the approved product list. If the product selected has guar gum tackifier included, then the additional 2% of tackifier will be guar gum. If the product selected has synthetic tackifier included, then the additional 2% of tackifier will be synthetic.

Fiber mulch will be applied at the rate of 3,000 pounds per acre.

The Contractor will allow the fiber mulch to cure a minimum of 18 hours prior to watering or any storm event to ensure proper cohesion between the soil and fiber particles.

All costs for the additional tackifier added to the fiber mulch including labor, equipment, and materials will be incidental to the contract unit price per pound for "Fiber Mulching".

The fiber mulch provided will be from the approved product list. The approved product list for fiber mulch may be viewed at the following internet site:

<http://apps.sd.gov/HC60ApprovedProducts/main.aspx>

EROSION CONTROL WATTLE

Erosion control wattles for restraining the flow of runoff and sediment will be installed at locations noted in the plans and at locations determined by the Engineer during construction. Refer to Standard Plate 734.06 for details.

The Contractor will provide certification that the erosion control wattles do not contain noxious weed seeds.

Erosion control wattles will remain on the project until vegetation has been established and then they will be removed in accordance with the Engineer.

The erosion control wattle provided will be from the approved product list. The approved product list for erosion control wattle may be viewed at the following internet site:

<http://apps.sd.gov/HC60ApprovedProducts/main.aspx>

STREET SWEEPING

Vehicle tracking of sediment from the construction site will be minimized. Street sweeping will be used if erosion and sediment control best management practices are not adequate to prevent sediment from being tracked onto the street.

The Contractor will use a pickup broom having integral self-contained storage to clean the roadway. The pickup broom used will be a minimum of 6 feet wide and have working gutter brooms.

At a minimum, sweeping will be required:

1. Prior to opening any segment or roadway to traffic.
2. When sawing operations are underway in the inside driving lanes, the outside driving lanes and gutter may need to be swept to control dust.

All costs for cleaning the roadway with a pickup broom will be incidental to the contract unit price per hour for "Sweeping".



FOR BIDDING PURPOSES ONLY

TABLE OF EXCAVATION QUANTITIES BY BALANCES

Station to	Station	Excavation (CuYd)	* Undercut (CuYd)	Total Excavation (CuYd)
10+50	13+50	12	36	48
13+50	17+00	15	38	53
20+00	23+50	10.5	32	42
23+50	27+00	13	39	52
27+00	30+50	13.5	39	52
30+50	34+00	13	39	52
34+00	35+50.43	4	10	14
40+00	43+50	15	46	61
Totals:		96	277	373

* The quantities for these items are in the Estimate of Quantities under their respective contract items.

SIGN QUANTITIES

Station	Offset (L/R)	Sign Code	Sign Description	Reset Sign	Install Sign
				Each	SF
13+40	6.0R	Special	Maintenance	1	
16+45	10.0L	D3-1	Tower Rd/225th St	1	
21+48	12.0 L	R1-5A	Yield Here		9
22+43	6.0L	S1-1/W16-7P	School Crossing	1	
23+20	12.0R	R1-5A	Yield Here		9
24+60	15.0R	S1-1/W16-9P	School Advance	1	
26+30	8.0R	W14-3	No Passing Zone	1	
27+00	6.0R	S4-3P/R2-1/S4-2P	School Speed	1	
39+50	50.0R	R1-5A	Yield Here		9
40+52	10.0R	R1-5A	Yield Here		9
Subtotal:				6	36



FOR BIDDING PURPOSES ONLY



PROJECT	SHEET	TOTAL SHEETS
P TAPU(47)	11	112

PIPE QUANTITIES

Station	Offset (L/R)	Remove Pipe Culvert	Remove Pipe End Section for Reset	Reset FES	Connect to Existing MH	Storm Manhole	Nyloplast Area Drain	Reinforced Concrete		Corrugated Metal		PVC
		CMP	CMP	CMP				Circular		Circular		Circular
		18"	18"	18"		48" Round	12" Round	18" Cl. 2	FES	FES	18"	12"
		Ft	Each	Each	Each	Each	Each	Ft	Each	Each	LF	Ft
13+56.56-7.26L										2	22	
16+29.49-17.34L						1	1	28	1			21
21+94.69		10								1	16	
22+37.85-31.62L			1	1						1	10	
23+10.53-10.56R					1							
28+33.44												
	Subtotal:	10	1	1	1	1	1	28	1	5	58	31



All controls will be maintained in good working order. Necessary repairs will be initiated within 24 hours of the site inspection report. Include the technical reasoning for selecting each control. (check all that apply)

FOR BIDDING PURPOSES ONLY

SD DOT	PROJECT	SHEET	TOTAL SHEETS
	P TAPU(47)	12	112

STORMWATER POLLUTION PREVENTION PLAN CHECKLIST

(The numbers left of the title headings are **reference numbers** to the GENERAL PERMIT FOR STORM WATER DISCHARGES ASSOCIATED WITH CONSTRUCTION ACTIVITIES (Stormwater Permit))

5.3 (2): STAFF TRAINING/SWPPP IMPLEMENTATION

To promote stormwater management awareness specific for this project, the Contractor's Erosion Control Supervisor should provide correspondence of how the SWPPP will be implemented. The Contractor's Erosion Control Supervisor is responsible for providing this information at the preconstruction meeting, and subsequently completing an attendance log, which should identify site-specific implementation of the SWPPP and the names of the personnel who attended the preconstruction meeting. Documentation of the preconstruction meeting will be filed with the SWPPP documents.

5.3 (3): DESCRIPTION OF CONSTRUCTION ACTIVITIES

- **5.3 (3a): Project Limits** (See Title Sheet)
- **5.3 (3a): Project Description** (See Title Sheet)
- **5.3 (4): Site Map(s)** (See Title Sheet and Plans)
- **Major Soil Disturbing Activities** (check all that apply)
 - Clearing and grubbing
 - Excavation/borrow
 - Grading and shaping
 - Filling
 - Other (describe):
- **5.3 (3b): Total Project Area**
- **5.3 (3b): Total Area to be Disturbed**
- **5.3 (3c): Maximum Area Disturbed at One Time**
- **5.3 (3d): Existing Vegetative Cover (%)**
- **5.3 (3d): Description of Vegetative Cover**
- **5.3 (3e): Soil Properties:** AASHTO Soil or USDA-NRCS Soil Series Classification
- **5.3 (3f): Name of Receiving Water Body/Bodies**
Box Elder Creek
- **5.3 (3g): Location of Construction Support Activity Areas**

5.3 (3h): ORDER OF CONSTRUCTION ACTIVITIES

The Contractor will enter the Estimated Start Date.

Description	Estimated Start Date
Install stabilized construction entrance(s).	
Install perimeter protection where runoff may exit site.	
Install perimeter protection around stockpiles.	
Install channel and ditch bottom protection.	
Clearing and grubbing.	
Remove and stockpile topsoil.	
Stabilize disturbed areas.	
Install utilities, storm sewers, curb and gutter.	
Install inlet and culvert protection after completing storm drainage and other utility installations.	
Final grading.	
Final paving.	
Removal of protection devices.	
Reseed areas disturbed by removal activities.	

5.3 (5): DESCRIPTION AND MAINTENANCE OF CONTROL MEASURES

Perimeter Controls (See Detail Plan Sheets)

Description	Estimated Start Date
<input type="checkbox"/> Natural Buffers (within 50 ft of Waters of State)	
<input type="checkbox"/> Silt Fence	
<input checked="" type="checkbox"/> Erosion Control Wattles	
<input type="checkbox"/> Temporary Berm / Windrow	
<input type="checkbox"/> Floating Silt Curtain	
<input type="checkbox"/> Stabilized Construction Entrances	
<input type="checkbox"/> Entrance/Exit Equipment Tire Wash	
<input type="checkbox"/> Other:	

Structural Erosion and Sediment Controls

Description	Estimated Start Date
<input type="checkbox"/> Silt Fence	
<input type="checkbox"/> Temporary Berm/Windrow	
<input checked="" type="checkbox"/> Erosion Control Wattles	
<input type="checkbox"/> Temporary Sediment Barriers	
<input type="checkbox"/> Erosion Bales	
<input type="checkbox"/> Temporary Slope Drain	
<input type="checkbox"/> Turf Reinforcement Mat	
<input type="checkbox"/> Riprap	
<input type="checkbox"/> Gabions	
<input type="checkbox"/> Rock Check Dams	
<input type="checkbox"/> Sediment Traps/Basins	
<input type="checkbox"/> Culvert Inlet Protection	
<input type="checkbox"/> Transition Mats	
<input type="checkbox"/> Median/Area Drain Inlet Protection	
<input type="checkbox"/> Curb Inlet Protection	
<input type="checkbox"/> Interceptor Ditch	
<input type="checkbox"/> Concrete Washout Facility	
<input type="checkbox"/> Work Platform	
<input type="checkbox"/> Temporary Water Barrier	
<input type="checkbox"/> Temporary Water Crossing	
<input type="checkbox"/> Permanent Stormwater Ponds	
<input type="checkbox"/> Permanent Open Vegetated Swales	
<input type="checkbox"/> Natural Depressions to allow for Infiltration	
<input type="checkbox"/> Sequential Systems that combine several practices	
<input type="checkbox"/> Other:	

Dust Controls

Description	Estimated Start Date
<input type="checkbox"/> Tarps & Wind impervious fabrics	
<input type="checkbox"/> Watering	
<input type="checkbox"/> Stockpile location/orientation	
<input type="checkbox"/> Dust Control Chlorides	
<input type="checkbox"/> Other	

Dewatering BMPs

Description	Estimated Start Date
<input type="checkbox"/> Sediment Basins	
<input type="checkbox"/> Dewatering bags	
<input type="checkbox"/> Weir tanks	
<input type="checkbox"/> Temporary Diversion Channel	
<input type="checkbox"/> Other:	

Stabilization Practices (See Detail Plan Sheets)

(Stabilization measures will begin the following work day whenever earth disturbing activity on any portion of the site has temporarily or permanently ceased. Temporary stabilization will be completed as soon as practicable but no later than 14 days after initiating soil stabilization activities (3.18))

Description	Estimated Start Date
<input type="checkbox"/> Vegetation Buffer Strips	
<input type="checkbox"/> Temporary Seeding (Cover Crop Seeding)	
<input checked="" type="checkbox"/> Permanent Seeding	
<input type="checkbox"/> Sodding	
<input type="checkbox"/> Planting (Woody Vegetation for Soil Stabilization)	
<input type="checkbox"/> Mulching (Grass Hay or Straw)	
<input checked="" type="checkbox"/> Fiber Mulching (Wood Fiber Mulch)	
<input type="checkbox"/> Soil Stabilizer	
<input type="checkbox"/> Bonded Fiber Matrix	
<input type="checkbox"/> Fiber Reinforced Matrix	
<input type="checkbox"/> Erosion Control Blankets	
<input type="checkbox"/> Surface Roughening (e.g. tracking)	
<input type="checkbox"/> Other:	

Wetland Avoidance

Will construction and/or erosion and sediment controls impinge on regulated wetlands? Yes No If yes, the structural and erosion and sediment controls have been included in the total project wetland impacts and have been included in the 404 permit process with the USACE.

5.3 (6): PROCEDURES FOR INSPECTIONS

- Inspections will be conducted at least once every 7 days.
- All controls will be maintained in good working order. Necessary repairs will be initiated within 24 hours of the site inspection report.
- Silt fence will be inspected for depth of sediment and for tears to ensure the fabric is securely attached to the posts and that the posts are well anchored. Sediment buildup will be removed from the silt fence when it reaches 1/3 of the height of the silt fence.
- Sediment basins and traps will be checked. Sediment will be removed when depth reaches approximately 50 percent of the structure's capacity, and at the conclusion of the construction.
- Check dams will be inspected for stability. Sediment will be removed when depth reaches 1/2 the height of the dam.
- All seeded areas will be checked for bare spots, washouts, and vigorous growth free of significant weed infestations.
- Inspection and maintenance reports will be prepared on form DOT 298 for each site inspection, this form will also be used to document changes to the SWPPP. A copy of the completed inspection form will be filed with the SWPPP documents.
- The Project Engineer and Contractor's Erosion Control Supervisor are responsible for inspections. Maintenance and repair activities are the responsibility of the Contractor. The Project Engineer will complete the inspection and maintenance reports and distribute copies per the distribution instructions on DOT 298.

5.3 (7): POST CONSTRUCTION STORMWATER MANAGEMENT

Stormwater management will be handled by temporary controls outlined in "DESCRIPTION AND MAINTENANCE OF CONTROL MEASURES" above, and any permanent controls needed to meet permanent stormwater management needs in the post construction period will be shown in the plans and noted as permanent.

5.3 (8): POLLUTION PREVENTION PROCEDURES

5.3 (8a): Spill Prevention and Response Procedures

➤ **Material Management**

- Housekeeping
 - Only needed products will be stored on-site by the Contractor.
 - Except for bulk materials the contractor will store all materials under cover and/or in appropriate containers.
 - Products must be stored in original containers and labeled.
 - Material mixing will be conducted in accordance with the manufacturer's recommendations.
 - When possible, all products will be completely used before properly disposing of the container off-site.
 - The manufacturer's directions for disposal of materials and containers will be followed.
 - The Contractor's site superintendent will inspect materials storage areas regularly to ensure proper use and disposal.
 - Dust generated will be controlled in an environmentally safe manner.
- Hazardous Materials
 - Products will be kept in original containers unless the container is not resealable and provide secondary containment as applicable.
 - Original labels and material safety data sheets will be retained in a safe place to relay important product information.
 - If surplus product must be disposed of, manufacturer's label directions for disposal will be followed.
 - Maintenance and repair of all equipment and vehicles involving oil changes, hydraulic system drain down, de-greasing operations, fuel tank drain down and removal, and other activities which may result in

the accidental release of contaminants will be conducted on an impervious surface and under cover during wet weather to prevent the release of contaminants onto the ground.

- Wheel wash water will be collected and allowed to settle out suspended solids prior to discharge. Wheel wash water will not be discharged directly into any stormwater system or stormwater treatment system.
- Potential pH-modifying materials such as: bulk cement, cement kiln dust, fly ash, new concrete washings, concrete pumping, residuals from concrete saw cutting (either wet or dry), and mixer washout waters will be collected on site and managed to prevent contamination of stormwater runoff.

➤ **Spill Control Practices**

In addition to the previous housekeeping and management practices, the following practices will be followed for spill prevention and cleanup if needed.

- For all hazardous materials stored on site, the manufacturer's recommended methods for spill cleanup will be clearly posted. Site personnel will be made aware of the procedures and the locations of the information and cleanup supplies.
- Appropriate cleanup materials and equipment will be maintained by the Contractor in the materials storage area on-site. As appropriate, equipment and materials may include items such as brooms, dust pans, mops, rags, gloves, goggles, kitty litter, sand, sawdust, and plastic and metal trash containers specifically for cleanup purposes.
- All spills will be cleaned immediately after discovery and the materials disposed of properly.
- The spill area will be kept well ventilated and personnel will wear appropriate protective clothing to prevent injury from contact with a hazardous substance.
- After a spill a report will be prepared describing the spill, what caused it, and the cleanup measures taken. The spill prevention plan will be adjusted to include measures to prevent this type of spill from reoccurring, as well as clean up instructions in the event of reoccurrences.
- The Contractor's site superintendent, responsible for day-to-day operations, will be the spill prevention and cleanup coordinator.

➤ **Spill Response**

The primary objective in responding to a spill is to quickly contain the material(s) and prevent or minimize migration into stormwater runoff and conveyance systems. If the release has impacted on-site stormwater, it is critical to contain the released materials on-site and prevent their release into receiving waters. If a spill of pollutants threatens stormwater or surface water at the site, the spill response procedures outlined below must be implemented in a timely manner to prevent the release of pollutants.

- The Contractor's site superintendent will be notified immediately when a spill or the threat of a spill is observed. The superintendent will assess the situation and determine the appropriate response.

If spills represent an imminent threat of escaping erosion and sediment controls and entering receiving waters, personnel will be directed to respond immediately to contain the release and notify the superintendent after the situation has been stabilized.

- Spill kits containing appropriate materials and equipment for spill response and cleanup will be maintained by the Contractor at the site.

- If oil sheen is observed on surface water (e.g. settling ponds, detention ponds, swales), action will be taken immediately to remove the material causing the sheen. The Contractor will use appropriate materials to contain and absorb the spill. The source of the oil sheen will also be identified and removed or repaired as necessary to prevent further releases.
- If a spill occurs the superintendent or the superintendent's designee will be responsible for completing the spill reporting form and for reporting the spill to SDDANR.
- Personnel with primary responsibility for spill response and cleanup will receive training by the Contractor's site superintendent or designee. The training must include identifying the location of the spill kits and other spill response equipment and the use of spill response materials.
- Spill response equipment will be inspected and maintained as necessary to replace any materials used in spill response activities.

5.3 (8b): WASTE MANAGEMENT PROCEDURES

➤ **Waste Disposal**

- All liquid waste materials will be collected and stored in approved sealed containers. All trash and construction debris from the site will be deposited in the approved containers. Containers will be serviced as necessary, and the trash will be hauled to an approved disposal site or licensed landfill. All onsite personnel will be instructed in the proper procedures for waste disposal and notices stating proper practices will be posted. The Contractor is responsible for ensuring waste disposal procedures are followed.

➤ **Hazardous Waste**

- All hazardous waste materials will be disposed of in a manner specified by local or state regulations or by the manufacturer. Site personnel will be instructed in these practices, and the Contractor will be responsible for seeing that these practices are followed.

➤ **Sanitary Waste**

- Portable sanitary facilities will be provided on all construction sites. Sanitary waste will be collected from the portable units which must be secured to prevent tipping and serviced in a timely manner by a licensed waste management Contractor or as required by any local regulations.

FOR BIDDING PURPOSES ONLY

5.3 (9): CONSTRUCTION SITE POLLUTANTS

The following materials or substances are expected to be present on the site during the construction period. These materials will be handled as noted under the heading "POLLUTION PREVENTION PROCEDURES" (check all that apply).

- Concrete and Portland Cement
- Detergents
- Paints
- Metals
- Bituminous Materials
- Petroleum Based Products
- Diesel Exhaust Fluid
- Cleaning Solvents
- Wood
- Cure
- Texture
- Chemical Fertilizers
- Other:

Product Specific Practices

▪ **Petroleum Products**

All on-site vehicles will be monitored for leaks and receive regular preventive maintenance to reduce the chance of leakage. Petroleum products will be stored in tightly sealed containers which are clearly labeled.

▪ **Fertilizers**

Fertilizers will be applied only in the amounts specified by the SDDOT. Once applied, fertilizers will be worked into the soil to limit the exposure to stormwater. Fertilizers will be stored in an enclosed area. The contents of partially used fertilizer bags will be transferred to sealable containers to avoid spills.

▪ **Paints**

All containers will be tightly sealed and stored when not required for use. The excess will be disposed of according to the manufacturer's instructions and any applicable state and local regulations.

▪ **Concrete Trucks**

Contractors will provide designated truck washout facilities on the site. These areas must be self-contained and not connected to any stormwater outlet of the site. Upon completion of construction, the area at the washout facility will be properly stabilized.

5.3 (10): NON-STORMWATER DISCHARGES

The following non-stormwater discharges are anticipated during the course of this project (check all that apply).

- Discharges from water line flushing.
- Pavement wash-water, where no spills or leaks of toxic or hazardous materials have occurred.
- Uncontaminated ground water associated with dewatering activities.

5.3 (11): INFEASIBILITY DOCUMENTATION

If it is determined to be infeasible to comply with any of the requirements of the Stormwater Permit, the infeasibility determination must be thoroughly documented in the SWPPP.

7.0: SPILL NOTIFICATION

In the event of a spill, the Contractor's site superintendent will make the appropriate notification(s), consistent with the following procedures:

- A release or spill of a regulated substance (includes petroleum and petroleum products) must be reported to SDDANR immediately **if any one of the following** conditions exists:
 - The release or spill threatens or is able to threaten waters of the state (surface water or ground water)
 - The release or spill causes an immediate danger to human health or safety
 - The release or spill exceeds 25 gallons
 - The release or spill causes a sheen on surface water
 - The release or spill of any substance that exceeds the ground water quality standards of ARSD Chapter 74:54:01
 - The release or spill of any substance that exceeds the surface water quality standards of ARSD Chapter 74:51:01
 - The release or spill of any substance that harms or threatens to harm wildlife or aquatic life
 - The release or spill is required to be reported according to Superfund Amendments and Reauthorization Act (SARA) Title III List of Lists, Consolidated List of Chemicals Subject to Reporting Under the Emergency Planning and Community Right to Know Act, US Environmental Protection Agency.
- To report a release or spill, call SDDANR at 605-773-3296 during regular office hours (8 a.m. to 5 p.m. Central Standard Time). To report the release after hours, on weekends or holidays, call South Dakota Emergency Management at 605-773-3231. Reporting the release to SDDANR does not meet any obligation for reporting to other state, local, or federal agencies. Therefore, you must also contact local authorities to determine the local reporting requirements for releases. A written report of the unauthorized release of any regulated substance, including quantity discharged, and the location of the discharge will be sent to SDDANR within 14 days of the discharge.

5.4: SWPPP CERTIFICATIONS

➤ **Certification of Compliance with Federal, State, and Local Regulations**

The Storm Water Pollution Prevention Plan (SWPPP) for this project reflects the requirements of all local municipal jurisdictions for storm water management and sediment and erosion control as established by ordinance, as well as other state and federal requirements for sediment and erosion control plans, permits, notices or documentation as appropriate.

➤ **South Dakota Department of Transportation**

I certify under penalty of law that this document and all attachments were prepared under my direction or supervision in accordance with a system designed to assure that qualified personnel properly gather and evaluate the information submitted. Based on my inquiry of the person or persons who manage the system, or those persons directly responsible for gathering the information, the information submitted is, to the best of my knowledge and belief, true, accurate, and complete. I am aware that there are significant penalties for submitting false information, including the possibility of fine and imprisonment for knowing violations.



Authorized Signature (See the General Permit, Section 7.4 (1))

➤ **Prime Contractor**

This section is to be executed by the General Contractor after the award of the contract. This section may be executed any time there is a change in the Prime Contractor of the project.

I certify under penalty of law that this document and all attachments will be revised or maintained under my direction or supervision in accordance with a system designed to assure that qualified personnel properly gather and evaluate the information submitted. Based on my inquiry of the person or persons who manage the system, or those persons directly responsible for gathering the information, the information submitted is, to the best of my knowledge and belief, true, accurate, and complete. I am aware that there are significant penalties for submitting false information, including the possibility of fine and imprisonment for knowing violations.

Authorized Signature

**CONTACT INFORMATION**

The following personnel are duly authorized representatives and have signatory authority for modifications made to the SWPPP:

➤ **Contractor Information:**

- Prime Contractor Name: _____
- Contractor Contact Name: _____
- Address: _____
- _____
- City: _____ State: _____ Zip: _____
- Office Phone: _____ Field: _____
- Cell Phone: _____ Fax: _____

➤ **Erosion Control Supervisor**

- Name: _____
- Address: _____
- _____
- City: _____ State: _____ Zip: _____
- Office Phone: _____ Field: _____
- Cell Phone: _____ Fax: _____

➤ **Project Engineer**

- Name: _____
- Business Address: _____
- Job Office Location: _____
- City: _____ State: _____ Zip: _____
- Office Phone: _____ Field: _____
- Cell Phone: _____ Fax: _____

➤ **SDDANR Contact Spill Reporting**

- Business Hours Monday-Friday (605) 773-3296
- Nights and Weekends (605) 773-3231

➤ **SDDANR Contact for Hazardous Materials.**

- (605) 773-3153

➤ **National Response Center Hotline**

- (800) 424-8802.

➤ **SDDANR Stormwater Contact Information**

- SDDANR Stormwater (800) 737-8676
- Surface Water Quality Program (605) 773-3351

5.5: REQUIRED SWPPP MODIFICATIONS

➤ **5.5 (1): Conditions Requiring SWPPP Modification**

The SWPPP must be modified, including the site map(s), in response to any of the following conditions:

- When a new operator responsible for implementation of any part the SWPPP begins work on the site.
- When changes to the construction plans, sediment and erosion control measures, or any best management practices on site that are no longer accurately reflected in the SWPPP. This includes changes made in response to corrective actions triggered by inspections.
- To reflect areas on the site map where operational control has been transferred (including the date of the transfer) or has been covered under a new permit since initiating coverage under this general permit.
- If inspections by site staff, local officials, SDDANR, or U.S. EPA determine that SWPPP modifications are necessary for compliance with the Stormwater Permit.
- To reflect any revisions to applicable federal, state, or local requirements that affect the control measures implemented at the site.
- If approved by the Secretary, to reflect any changes in chemical water treatment systems or controls, including the use of a different water treatment chemical, age rates, different areas, or methods of application.

➤ **5.5 (2): Deadlines for SWPPP Modification**

Any required revisions to the SWPPP must be completed within 7 calendar days following any of the items listed above.

➤ **5.5 (3): Documentation of Modifications to the Plan**

All SWPPP modification records are required to be maintained showing the dates of when the modification occurred. The records must include the name of the person authorizing each change and a brief summary of all changes.

➤ **5.5 (4): Certification Requirements**

All modifications made to the SWPPP must be signed and certified as required in Section 7.4.

➤ **5.5 (5): Required Notice to Other Operators**

If there are multiple operators at the site, the Contractor's Erosion Control Supervisor must notify each operator that may be impacted by the change to the SWPPP within 24 hours.

When modifications as described above occur, the SWPPP will be modified to provide appropriate protection to disturbed areas, all storm water structures, and adjacent waters. The Project Engineer will modify the SWPPP using the DOT 298 form and drawings on the plan will be modified to reflect the needed changes. Copies of the DOT 298 forms and the SWPPP will be retained on site in a designated place for review throughout the course of the project. A copy of the DOT 298 form will be given to the Contractor Erosion Control Supervisor and a copy will be emailed to the SDDOT Environmental Section in accordance with the DOT 298 Form.



PROJECT	SHEET	TOTAL SHEETS
P TAPU(47)	16	112

TYPICAL SECTIONS

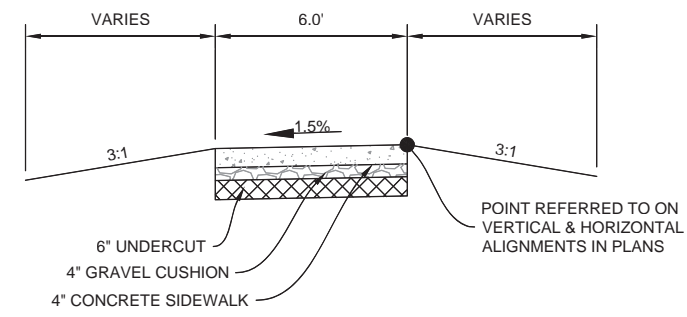

SIDEWALK
22+68.34 TO 34+57.30
40+25.00 TO 41+69.75

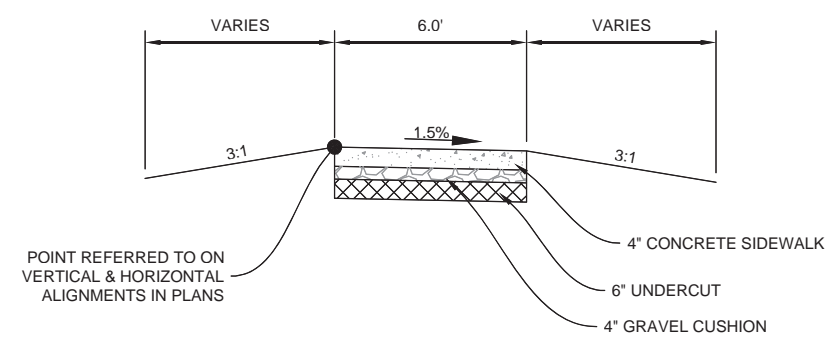

SIDEWALK
10+25.00 TO 16+46.41
20+25.00 TO 20+36.18
20+56.71 TO 22+07.96
44+33.45 TO 44+74.04

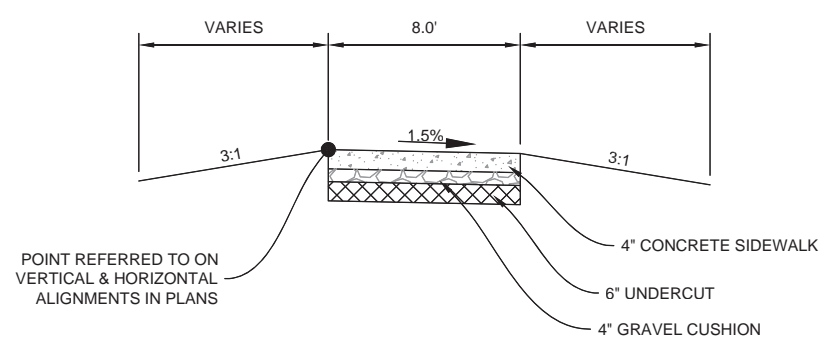

SIDEWALK
42+10.83 TO 44+33.45

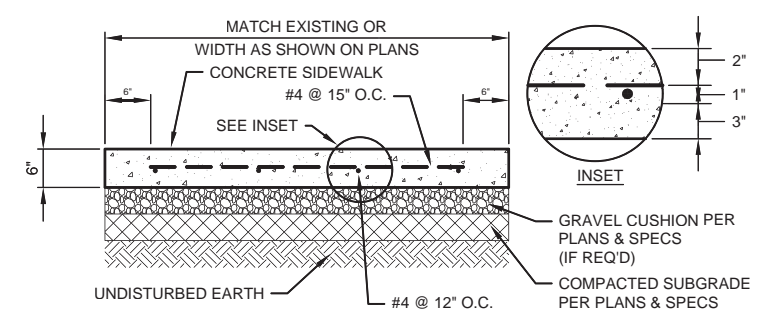

- NOTES:**
- CONSTRUCTION JOINTS SPACED 5' MINIMUM AND 8' MAXIMUM.
 - SIDEWALK WIDTH 5' OR LESS - JOINT SPACING 5' SIDEWALK WIDTH MORE THAN 5' - JOINT SPACING 6'-8'.
 - CONTROL JOINTS SHALL BE SAWED OR TOOLED TO 1/4 CONCRETE DEPTH (MINIMUM).
 - EXPANSION JOINTS EVERY 60 LF (MAXIMUM), EXPANSION JOINTS AT EVERY PROPERTY LINE, EXPANSION JOINTS AT DRIVEWAYS, EXPANSION JOINTS AT ALL CURB RETURNS ON RADII AND SEALED WITH BACKER ROD AND SEALANT AS SHOWN IN THE EXPANSION JOINT SEAL PLAN DETAIL.

REINFORCED SIDEWALK
NO SCALE 20+22.00 TO 20+44.50



TRAFFIC CONTROL AND FIXED LOCATION SIGNING

FOR BIDDING PURPOSES ONLY



PROJECT	SHEET	TOTAL SHEETS
P TAPU(47)	17	112

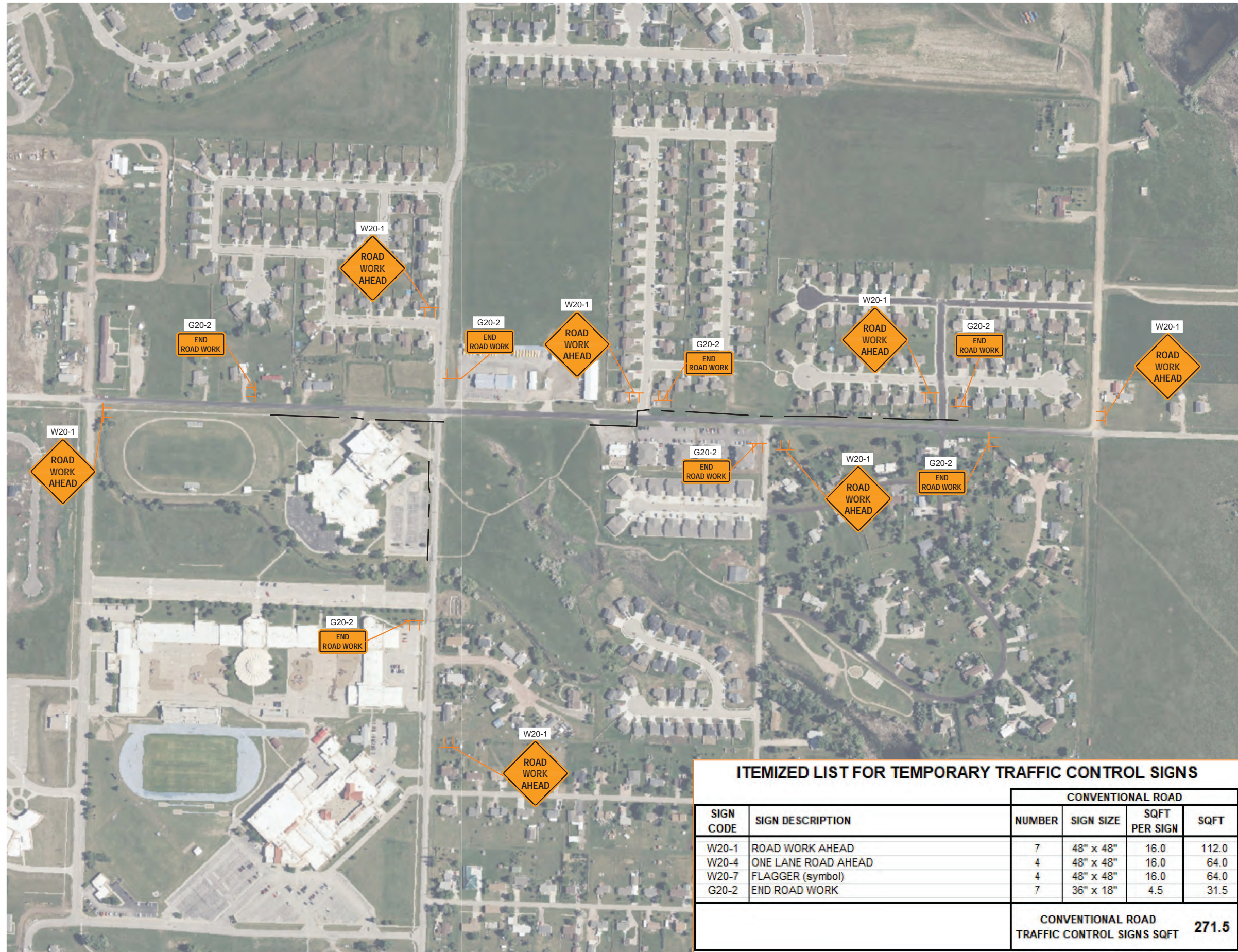

ITEMIZED LIST FOR TEMPORARY TRAFFIC CONTROL SIGNS					
SIGN CODE	SIGN DESCRIPTION	CONVENTIONAL ROAD			
		NUMBER	SIGN SIZE	SQFT PER SIGN	SQFT
W20-1	ROAD WORK AHEAD	7	48" x 48"	16.0	112.0
W20-4	ONE LANE ROAD AHEAD	4	48" x 48"	16.0	64.0
W20-7	FLAGGER (symbol)	4	48" x 48"	16.0	64.0
G20-2	END ROAD WORK	7	36" x 18"	4.5	31.5
CONVENTIONAL ROAD TRAFFIC CONTROL SIGNS SQFT					271.5

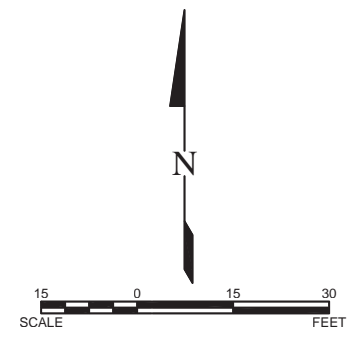

TRAFFIC CONTROL AND FIXED LOCATION SIGNING

FOR BIDDING PURPOSES ONLY



PROJECT	SHEET	TOTAL SHEETS
P TAPU(47)	18	112

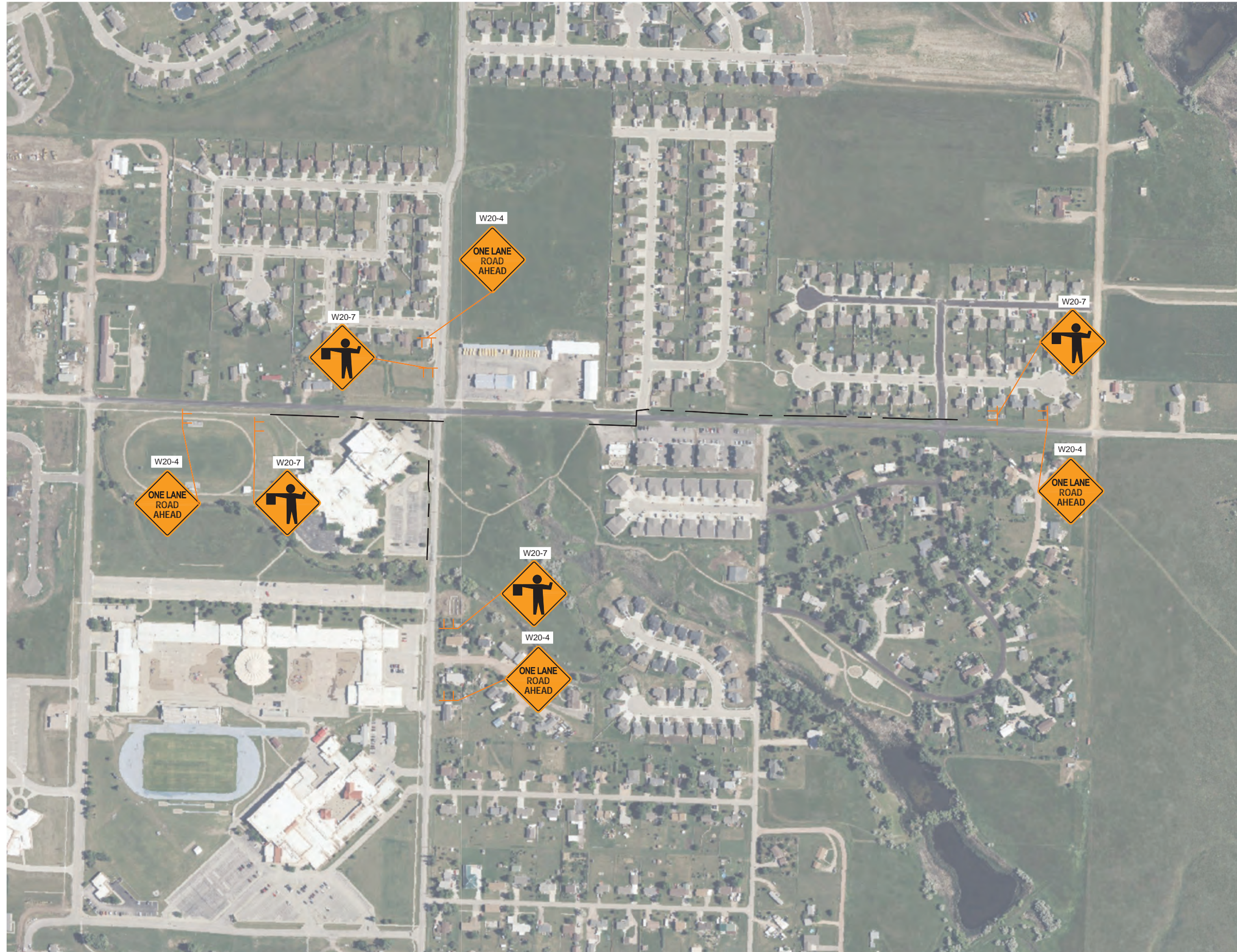

NOTES:
CONTRACTOR TO SHORTEN LANE CLOSE TO ACCOMMODATE ACTUAL WORK AREA.

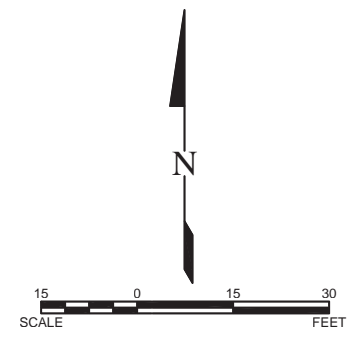

FOR BIDDING PURPOSES ONLY



PROJECT	SHEET	TOTAL SHEETS
P TAPU(47)	19	112

EROSION CONTROL

QUANTITIES THIS SHEET

TYPE D PERMANENT SEED MIXTURE	23.9 LB
FERTILIZING	116.1 LB
MULCHING	235.6 LB

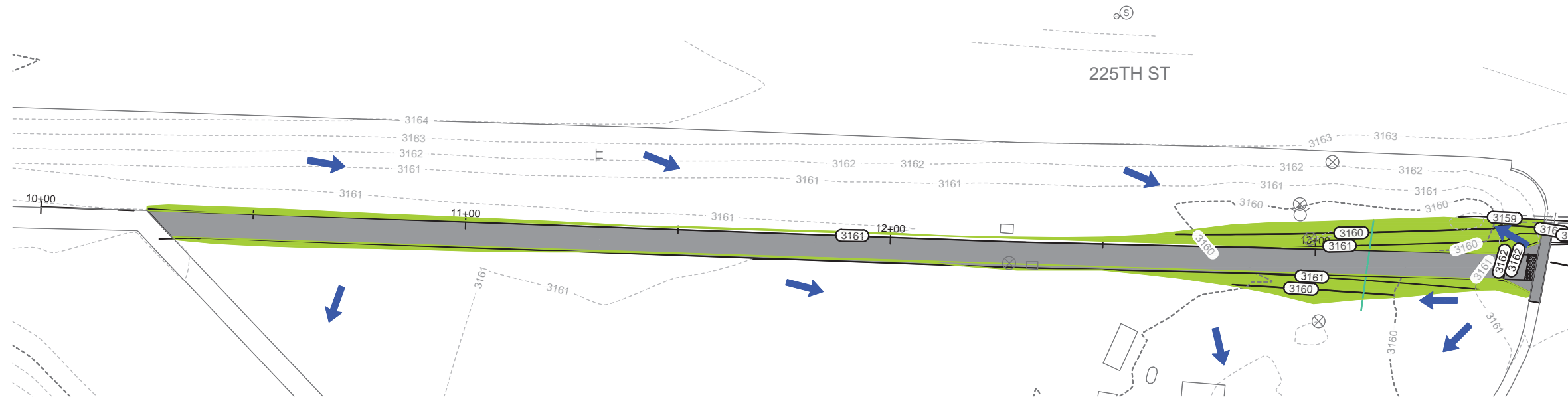

STA. 10+00 TO 13+50

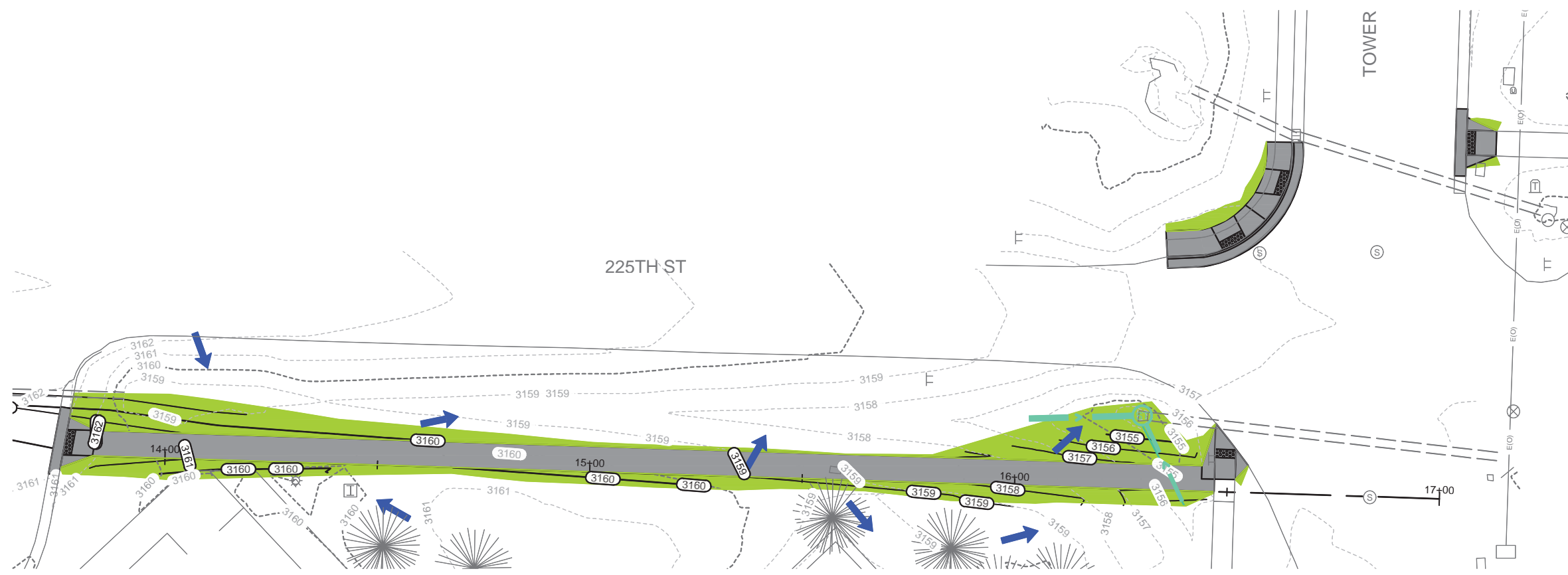

STA. 13+50 TO 17+00

LEGEND

- FLOW DIRECTION
- EROSION CONTROL WATTLES
- FERTILIZING, SEEDING, & MULCHING





PROJECT	SHEET	TOTAL SHEETS
P TAPU(47)	20	112

FOR BIDDING PURPOSES ONLY

EROSION CONTROL

QUANTITIES THIS SHEET

9" DIAMETER EROSION CONTROL WATTLE	25 FT
TYPE D PERMANENT SEED MIXTURE	17.4 LB
FERTILIZING	84.5 LB
MULCHING	171.4 LB

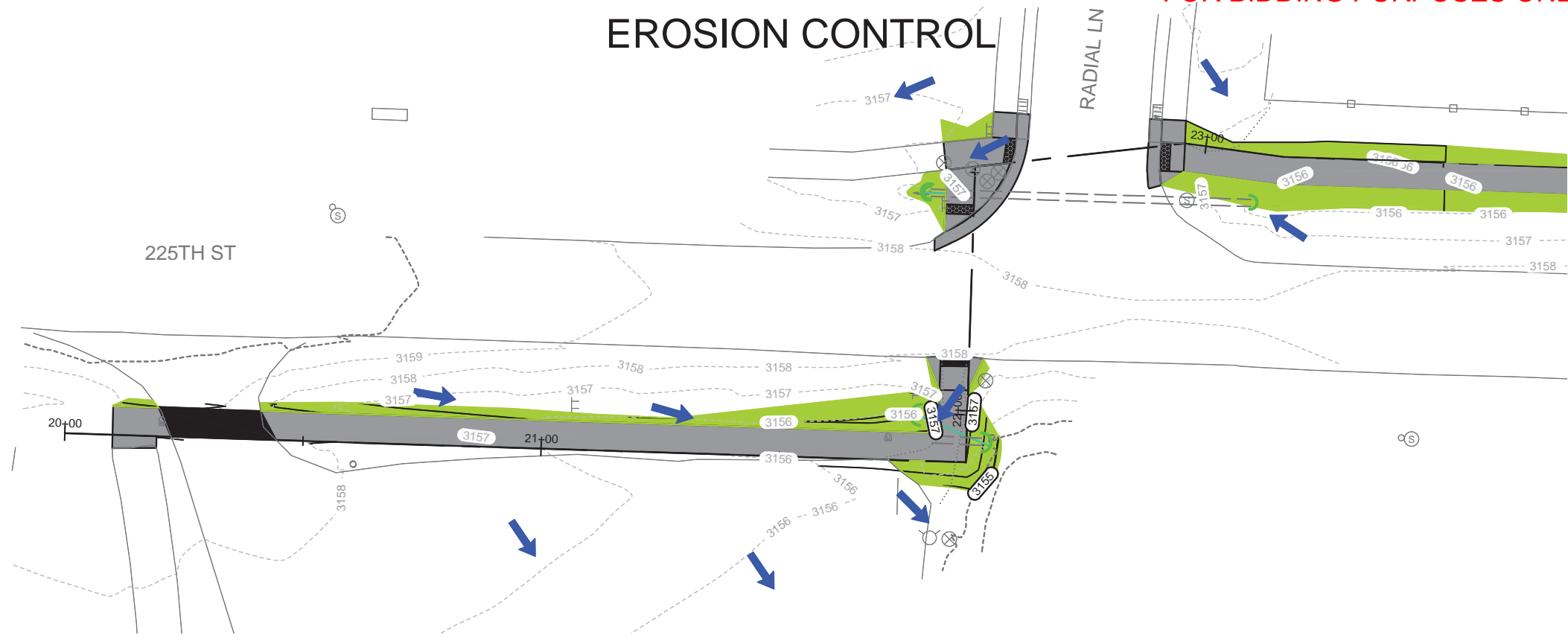

STA. 20+00 TO 23+50

LEGEND

- FLOW DIRECTION
- EROSION CONTROL WATTLES
- FERTILIZING, SEEDING, & MULCHING

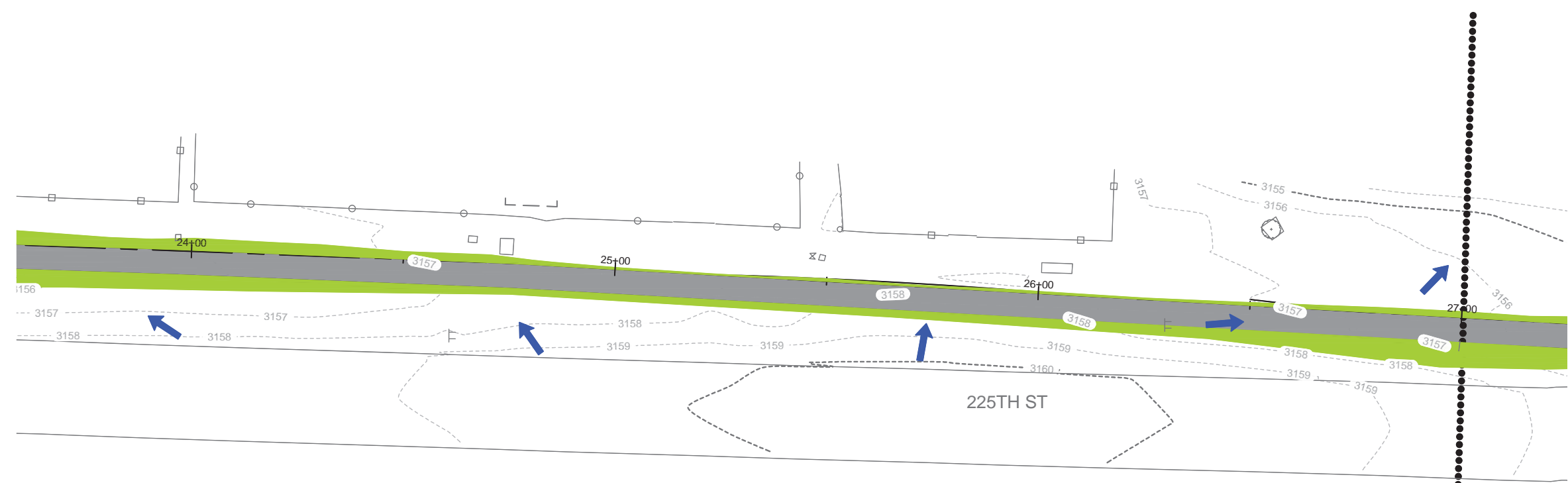

STA. 23+50 TO 27+00

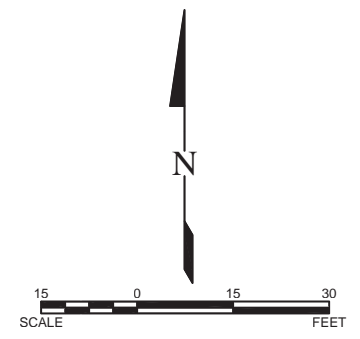

FOR BIDDING PURPOSES ONLY



PROJECT	SHEET	TOTAL SHEETS
P TAPU(47)	21	112

EROSION CONTROL

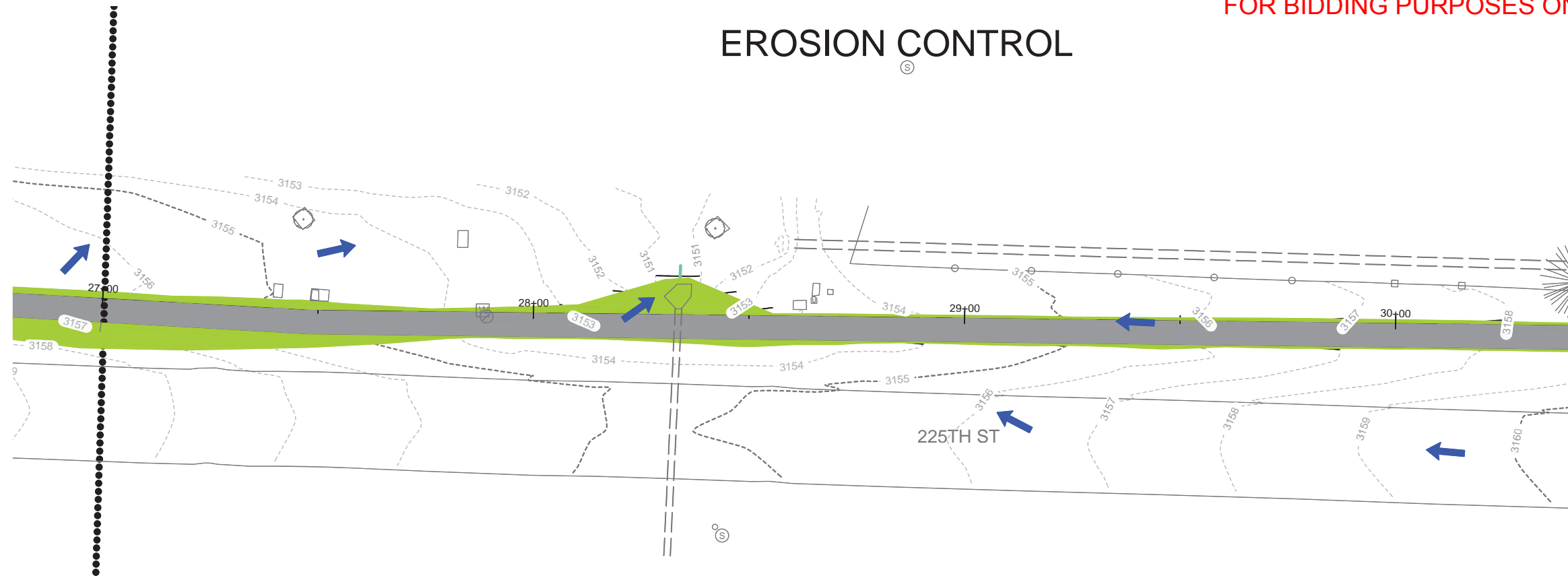

QUANTITIES THIS SHEET

TYPE D PERMANENT SEED MIXTURE	10 LB
FERTILIZING	48.4 LB
MULCHING	98.2 LB



STA. 27+00 TO 30+50

LEGEND

-  FLOW DIRECTION
-  EROSION CONTROL WATTLES
-  FERTILIZING, SEEDING, & MULCHING

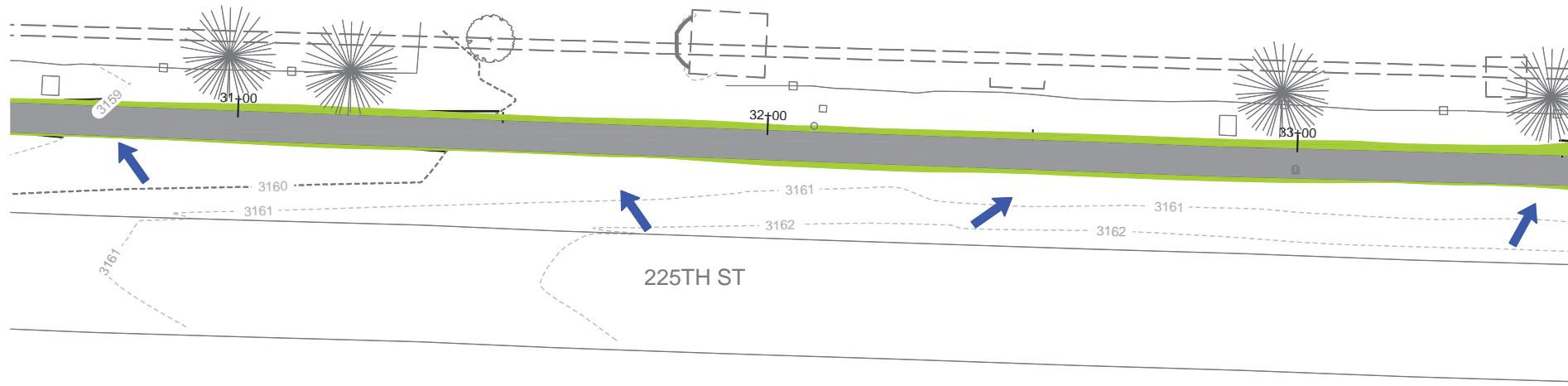

STA. 30+50 TO 33+50

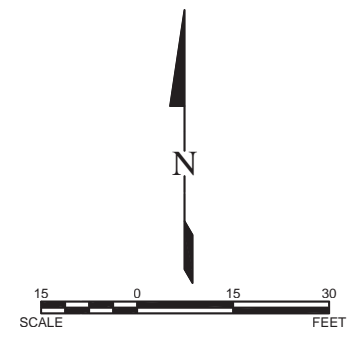

FOR BIDDING PURPOSES ONLY

SD DOT	PROJECT	SHEET	TOTAL SHEETS
	P TAPU(47)	22	112

EROSION CONTROL

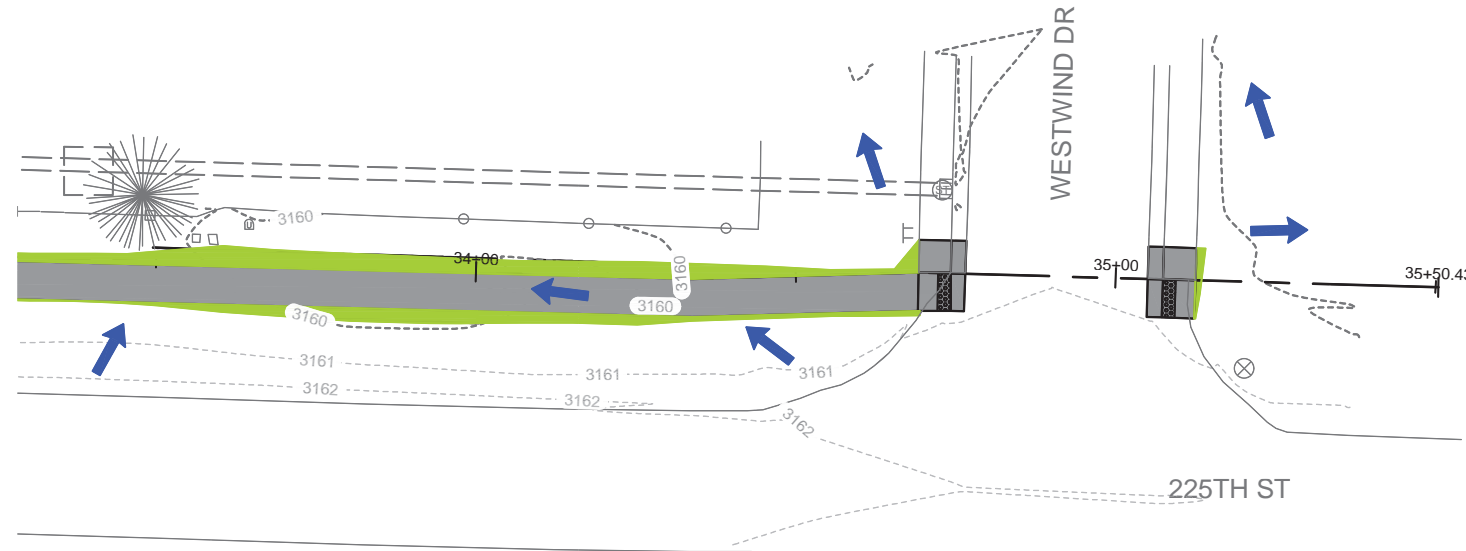

QUANTITIES THIS SHEET

TYPE D PERMANENT SEED MIXTURE	1.4 LB
FERTILIZING	7.0 LB
MULCHING	14.1 LB



STA. 33+50 TO 35+50

LEGEND

-  FLOW DIRECTION
-  EROSION CONTROL WATTLES
-  FERTILIZING, SEEDING, & MULCHING



FOR BIDDING PURPOSES ONLY

SD DOT	PROJECT	SHEET	TOTAL SHEETS
	P TAPU(47)	23	112

EROSION CONTROL

QUANTITIES THIS SHEET

TYPE D PERMANENT SEED MIXTURE	3.2 LB
FERTILIZING	15.6 LB
MULCHING	31.7 LB

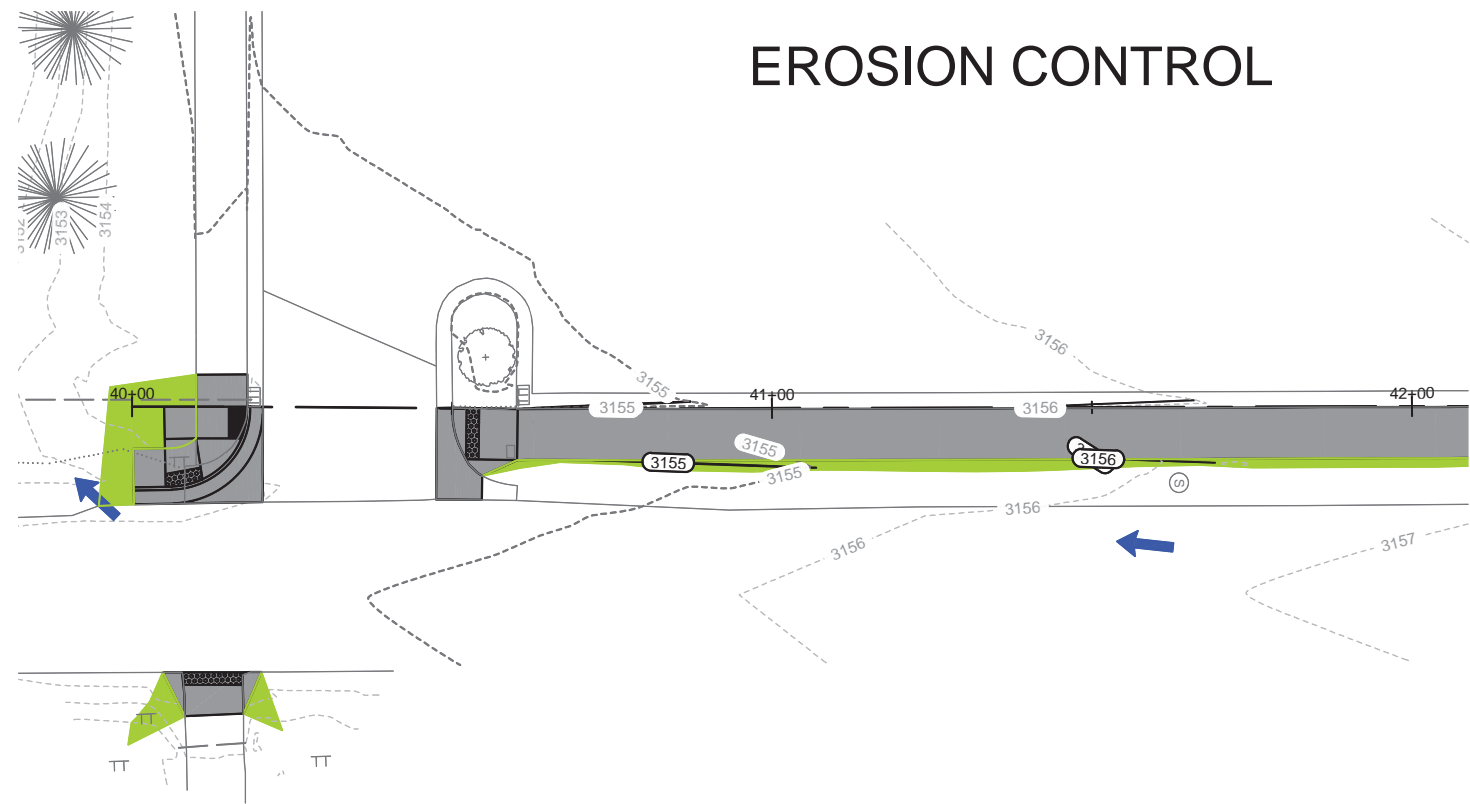

STA. 40+00 TO 42+00

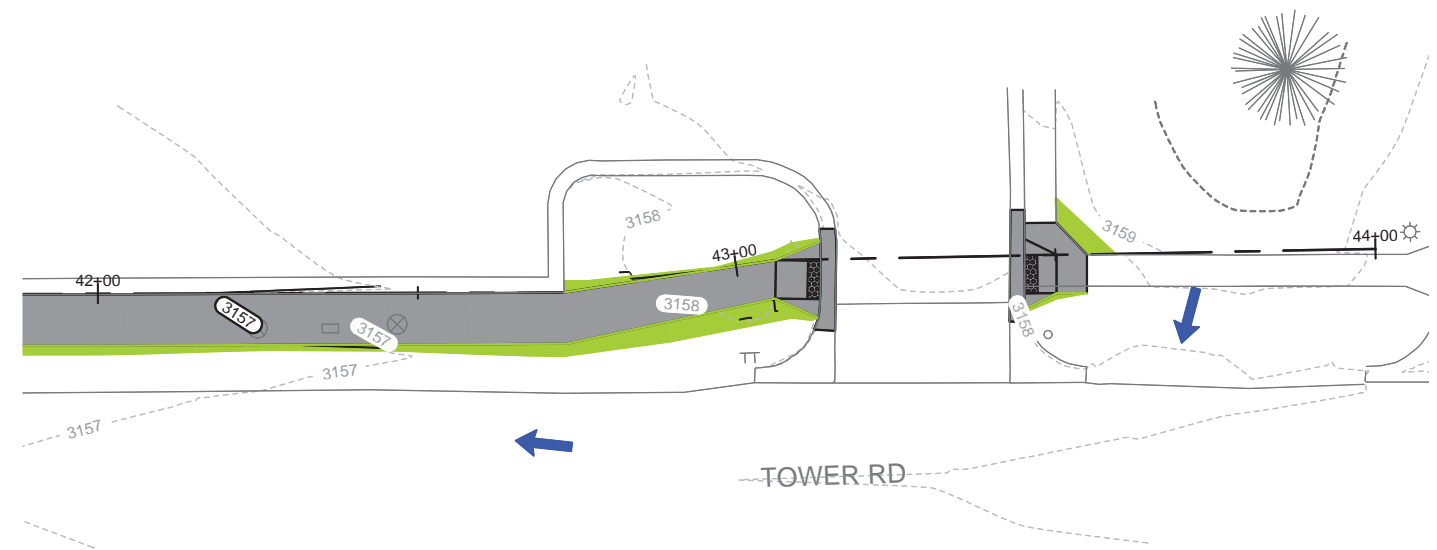

STA. 42+00 TO 44+00

LEGEND

- ← FLOW DIRECTION
- EROSION CONTROL WATTLES
- FERTILIZING, SEEDING, & MULCHING

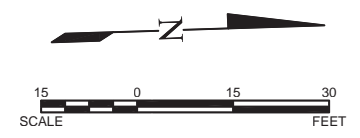

HORIZONTAL ALIGNMENT & SURVEY CONTROL

FOR BIDDING PURPOSES ONLY

	PROJECT	SHEET	TOTAL SHEETS
	P TAPU(47)	24	112



POINT TABLE				
POINT #	NORTHING	EASTING	ELEVATION	DESCRIPTION
1	668304.54	1251034.33	3160.59	CP CP1 5/8" REBAR W/ KLJ AC
2	667723.57	1251062.95	3163.62	CP CP2 5/8" REBAR W/ KLJ AC
12	671913.91	1252737.15	3175.35	CP CP12 5/8" REBAR W/ KLJ AC
13	671121.55	1252784.84	3164.24	CP CP13 5/8" REBAR W/ KLJ AC
14	670167.96	1254925.01	3159.16	CP CP14 5/8" REBAR W/ KLJ AC
15	670196.68	1252995.43	3153.17	CP CP15 5/8" REBAR W/ KLJ AC
16	670342.05	1251855.36	3163.85	CP CP16 5/8" REBAR W/ KLJ AC

THE BASIS OF BEARING AND COORDINATES FOR THIS SURVEY ARE SOUTH DAKOTA STATE PLANE COORDINATES SOUTH ZONE, NAD83(2011) IN US FEET.

VERTICAL DATUM IS NAVD 88
ELEVATIONS DERIVED FROM GEOID18

THE LOCATION OF UTILITIES DEPICTED HEREON WERE DERIVED FROM UTILITY LOCATES FROM SOUTH DAKOTA ONE CALL AND FOUND APPURTENANCES. FOR THE EXACT LOCATION AND NATURE OF UTILITIES, CONTACT THE APPROPRIATE UTILITY COMPANIES.

FIELD SURVEY CONDUCTED FEBRUARY 2025
FIELD BOOKS RC 005 PAGES 25-31, RC 006 PAGES 16-31



Alignment 1 - North of School (Along 225th St west of Tower Rd)									
Number		Station	Length	Radius	Line/Chord Direction	Delta		Northing	Easting
L1	B E	10+00.00 10+24.72	24.72'		S88° 19' 53.91"E		B E	670262.82 670262.10	1251995.19 1252019.90
L2	B E	10+25.28 13+52.35	327.07'		S88° 10' 24.69"E		B E	670262.08 670251.65	1252020.45 1252347.36
L3	B E	13+52.35 13+76.19	23.84'		S73° 35' 40.32"E		B E	670251.65 670244.92	1252347.36 1252370.23
L4	B E	13+76.19 16+47.30	271.12'		S88° 10' 25.74"E		B E	670244.92 670236.28	1252370.23 1252641.20
L5	B E	16+47.30 17+00.00	52.70'		S89° 13' 13.77"E		B E	670236.28 670235.57	1252641.20 1252693.90

Alignment 2 - Northeast of School (Along 225th St east of Tower Rd)									
Number		Station	Length	Radius	Line/Chord Direction	Delta		Northing	Easting
L6	B E	20+00.00 21+83.61	183.61'		S89° 05' 53.21"E		B E	670214.15 670211.26	1253291.02 1253474.61
L7	B E	21+83.61 22+50.80	67.19'		N1° 48' 56.51"E		B E	670211.26 670278.42	1253474.61 1253476.74
L8	B E	22+50.80 22+95.11	44.31'		N83° 39' 30.95"E		B E	670278.42 670283.31	1253476.74 1253520.77
L9	B E	22+95.11 23+16.08	20.96'		S82° 17' 35.21"E		B E	670283.31 670280.50	1253520.77 1253541.55
L10	B E	23+16.08 24+75.36	159.28'		S87° 52' 22.16"E		B E	670280.50 670274.59	1253541.55 1253700.72
L11	B E	24+75.36 27+47.67	272.31'		S86° 44' 08.59"E		B E	670274.59 670259.08	1253700.72 1253972.59
L12	B E	27+47.67 30+50.43	302.76'		S89° 18' 25.60"E		B E	670259.08 670255.42	1253972.59 1254275.32
L13	B E	30+50.43 34+33.53	383.10'		S88° 08' 00.80"E		B E	670255.42 670242.94	1254275.32 1254658.22
L14	B E	34+33.53 34+68.77	35.24'		N88° 20' 40.17"E		B E	670242.94 670243.96	1254658.22 1254693.45
L15	B E	34+68.77 35+45.79	77.02'		S88° 23' 07.43"E		B E	670243.96 670241.79	1254693.45 1254770.44

Alignment 3 - East of School (Along Tower Rd south of 225th St)									
Number		Station	Length	Radius	Line/Chord Direction	Delta		Northing	Easting
L16	B E	40+00.00 40+18.00	18.00'		N2° 03' 40.72"E		B E	669675.54 669693.53	1252627.95 1252628.60
L17	B E	40+18.00 40+60.07	42.07'		N2° 29' 30.34"E		B E	669693.53 669735.56	1252628.60 1252630.43
L18	B E	40+60.07 42+72.72	212.65'		N1° 51' 01.06"E		B E	669735.56 669948.10	1252630.43 1252637.29
L19	B E	42+72.72 43+06.30	33.58'		N6° 38' 47.47"W		B E	669948.10 669981.46	1252637.29 1252633.41
L20	B E	43+06.30 44+00.00	93.70'		N0° 56' 39.66"E		B E	669981.46 670075.14	1252633.41 1252634.95



LEGEND		
EXISTING	ITEM	PROPOSED
	FIRE HYDRANT	
	GATE VALVE	
	CURB STOP	
	YARD HYDRANT	
	BEND	
	TEE	
	CROSS	
	REDUCER	
	COUPLER	
	VERTICAL BEND	
	WATER MANHOLE	
	SPRINKLER HEAD	
	WATER METER	
	CATHODIC TEST STATION	
	TRACER WIRE ACCESS BOX	
	SANITARY MANHOLE	
	SANITARY FORCEMAIN MANHOLE	
	SANITARY MANHOLE W. VALVE	
	CLEANOUT	
	STORM SEWER MANHOLE	
	CURB INLET	
	CATCH BASIN	
	POWER POLE	
	GUY WIRE	
	LIGHT POLE	
	ELECTRICAL PEDESTAL	
	ELECTRICAL METER	
	ELECTRICAL JUNCTION (PULL BOX)	
	ELECTRICAL BOX	
	ELECTRICAL OUTLET/PLUG-IN	
	ELECTRICAL MANHOLE	
	TELEPHONE MANHOLE	
	TELEPHONE PEDESTAL	
	CABLE TV PEDESTAL	
	FIBER OPTIC PEDESTAL	
	GAS METER	
	GAS MANHOLE	
	FUEL DISPENSER	
	UTILITY MARKER	
	GAS VENT PIPE	
	TREES CONIFEROUS/ DECIDUOUS	
	BUSH/SHRUB	
	SIGN	
	CONTROL POINT	
	BENCHMARK	
	PIPE CAP	
	MAIL BOX	
	PROPERTY PIN	

LEGEND		
EXISTING	ITEM	PROPOSED
	ASPHALT EDGE	
	BUILDING CANOPY	
	CABLE TV - UNDERGROUND	
	CENTERLINE	
	CONSTRUCTION LIMITS	
	ELECTRICAL - OVERHEAD	
	ELECTRICAL - UNDERGROUND	
	FENCE - BARBED WIRE	
	FENCE - CHAINLINK	
	FENCE - PLASTIC, VINYL	
	FENCE - WOOD	
	FENCE - WOVEN WIRE	
	FIBER - UNDERGROUND	
	GAS - UNDERGROUND	
	GRAVEL EDGE	
	SANITARY SEWER FORCE MAIN	
	SANITARY SEWER SERVICE LINE	
	SANITARY SEWER (LESS THAN 24")	
	SANITARY SEWER (24" OR MORE)	
	STORM SEWER EDGEDRAIN	
	STORM SEWER (LESS THAN 24")	
	STORM SEWER (24" OR MORE)	
	TELEPHONE - OVERHEAD	
	TELEPHONE - UNDERGROUND	
	WATER SERVICE LINE	
	WATER MAIN	

AC	ASPHALT CEMENT	ES	END SECTION
AGGR	AGGREGATE	ESMT	EASEMENT
AHD	AHEAD	EX	EXISTING
APPROX	APPROXIMATE OR APPROXIMATELY	EXC	EXCAVATION
ARV	AIR RELEASE VALVE	FES	FLARED END SECTION
ASPH	ASPHALT	FF	FINISHED FLOOR
BIT	BITUMINOUS	FG	FINISHED GRADE
BK	BACK	GR	GRAVEL
BM	BENCH MARK	HDPE	HIGH DENSITY POLYETHYLENE PIPE
BLDG	BUILDING	HORZ	HORIZONTAL
C&G	CURB & GUTTER	HP	HIGH POINT
CI	CAST IRON	HYD	HYDRANT
CL	CENTERLINE	INST	INSTALL
CMES	CORRUGATED METAL END SECTION	INV	INVERT
CMP	CORRUGATED METAL PIPE	JB	JUNCTION BOX
CP	CONTROL POINT	L	LENGTH
CPP	CORRUGATED PLASTIC PIPE	LF	LINEAR OR LINEAL FEET
CONST	CONSTRUCTION	LONG	LONGITUDINAL
CONC	CONCRETE	LP	LOW POINT OR LIGHT POLE
CPLG	COUPLING	LS	LUMP SUM
CS	CURB STOP	LT	LEFT
CY	CUBIC YARD	MAX	MAXIMUM
D	DEGREE OF CURVATURE	ME	MATCH EXISTING
DB	DITCH BLOCK	MH	MANHOLE
DEFL	DEFLECTION	MIN	MINIMUM
DG	DITCH GRADE	PVC	POLYVINYL CHLORIDE PIPE
EA	EACH	P & P	PLAN & PROFILE
EL	ELEVATION	PC	POINT OF CURVATURE
ELEC	ELECTRIC	PCC	POINT OF COMPOUND CURVE
EMB	EMBANKMENT	PI	POINT OF INTERSECTION
EQ	EQUATION	PIV	POST INDICATOR VALVE

POC	POINT ON CURVE
POT	POINT ON TANGENT
PP	POWER POLE
PRC	POINT OF REVERSE CURVATURE
PRV	PRESSURE REDUCING VALVE
PT	POINT OF TANGENCY
PVI	POINT OF VERTICAL INTERSECTION
R	RADIUS
RCES	REINFORCED CONCRETE END SECTION
RCP	REINFORCED CONCRETE PIPE
RDWY	ROADWAY
RR	RAILROAD
RT	RIGHT
R/W ROW	RIGHT-OF-WAY
SALV	SALVAGE
SAN	SANITARY
SE	SUPERELEVATION
SEC	SECTION
SF	SQUARE FEET
SHLDR	SHOULDER
SSD	STOPPING SIGHT DISTANCE
SEC LINE	SECTION LINE
SPEC	SPECIFICATION
STA	STATION
STD	STANDARD
STRUCT	STRUCTURE
SURV	SURVEY
SW	SIDEWALK
SY	SQUARE YARD
T	TANGENT
TA	TOP OF ASPHALT
TBC	TOP BACK OF CURB
TC	TOP OF CONCRETE
TEL	TELEPHONE
TEMP	TEMPORARY
THEOR	THEORETICAL
TP	TOP OF PAVEMENT
TR	TRAFFIC
VC	VERTICAL CURVE
VCP	VITRIFIED CLAY PIPE
VERT	VERTICAL
WM	WATER MAIN
WV	WATER VALVE
XSEC	CROSS SECTION



PLAN AND PROFILES

FOR BIDDING PURPOSES ONLY



PROJECT	SHEET	TOTAL SHEETS
P TAPU(47)	27	112

QUANTITIES THIS SHEET

4" CONCRETE SIDEWALK	1961 SF
BASE COURSE	1 TON
GRAVEL CUSHION	36 TON
TYPE 1 DETECTABLE WARNINGS	12 SF
TYPE B68 CONCRETE CURB AND GUTTER	16 SF
18" CMP	22 LF
18" CMP FLARED END	2 EA

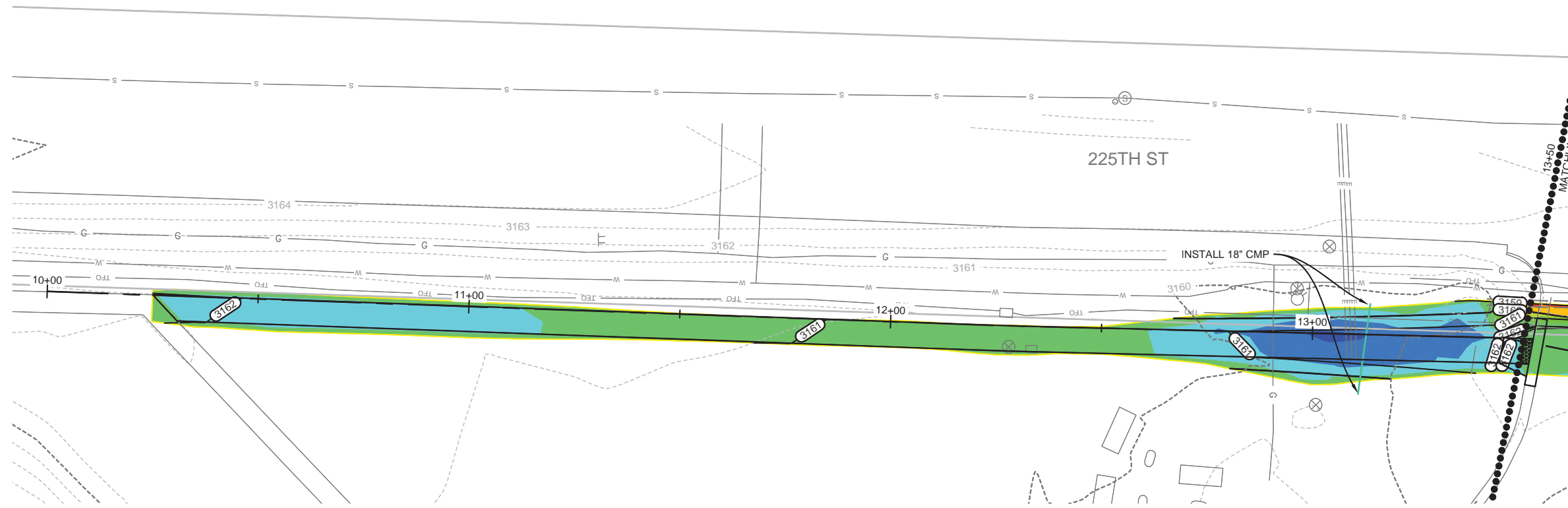

NUMBER	MINIMUM ELEVATION	MAXIMUM ELEVATION	COLOR
1	-4.41	-3.66	Red
2	-3.66	-2.82	Orange
3	-2.82	-2.04	Yellow
4	-2.04	-1.25	Light Green
5	-1.25	-0.44	Green
6	-0.44	0.35	Light Blue
7	0.35	1.15	Blue
8	1.15	1.94	Dark Blue
9	1.94	2.73	Dark Purple
10	2.73	3.53	Black

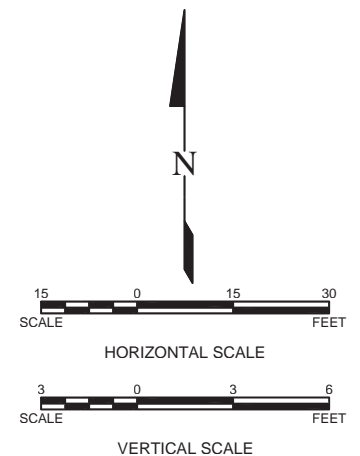
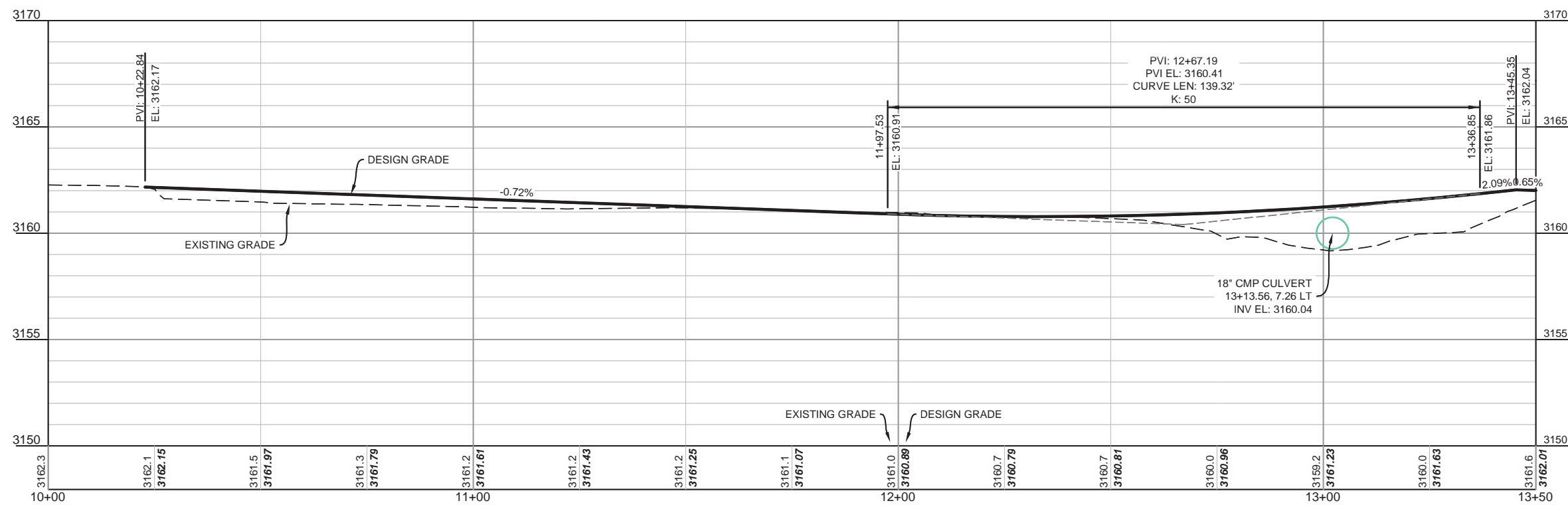

PLAN AND PROFILES

FOR BIDDING PURPOSES ONLY

SD DOT	PROJECT	SHEET	TOTAL SHEETS
	P TAPU(47)	28	112

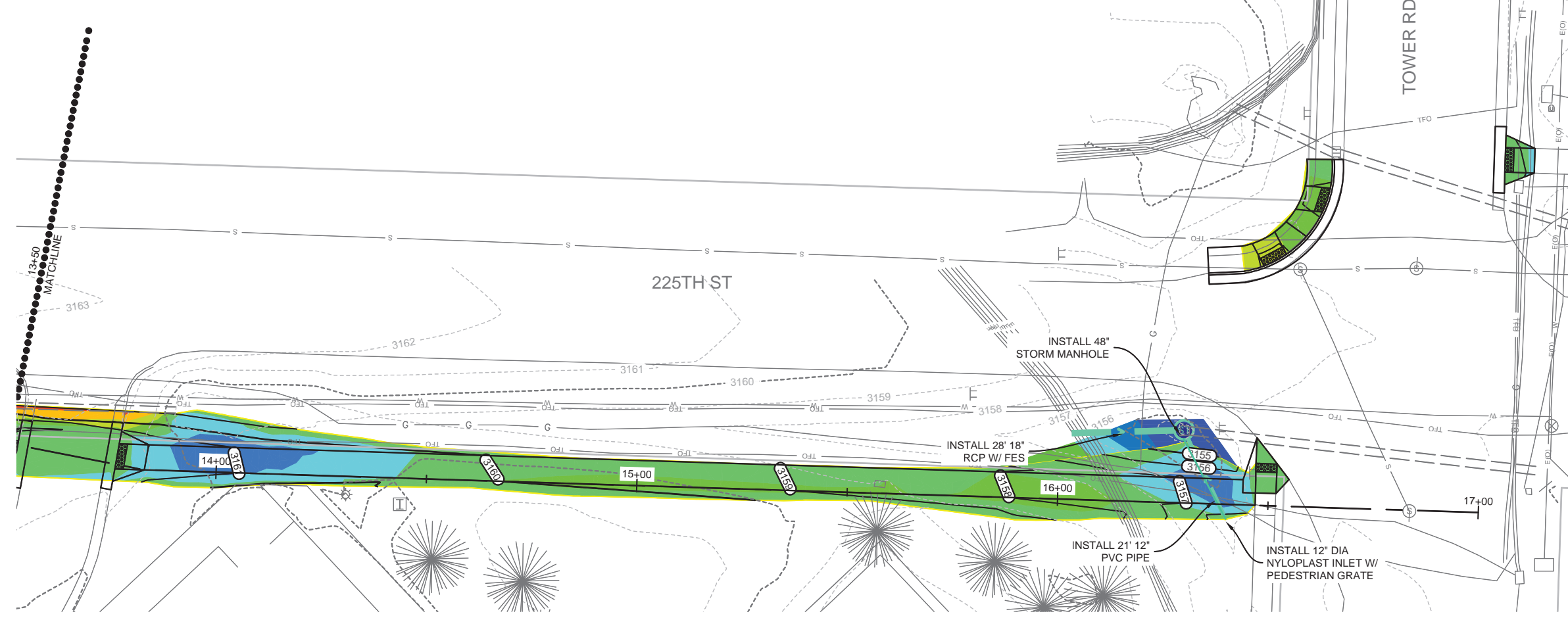

QUANTITIES THIS SHEET

4" CONCRETE SIDEWALK	2027 SF
TYPE B68 CONCRETE CURB AND GUTTER	82 LF
BASE COURSE	4 TON
GRAVEL CUSHION	37 TON
TYPE 1 DETECTABLE WARNINGS	60 SF
18" RCP	28 LF
12" PVC PIPE	21 LF
18" RCP FLARED END	1 EA
STORM MANHOLE	1 EA
12" DIA NYLOPLAST INLET	1 EA

SURFACE ELEVATION DATA

NUMBER	MINIMUM ELEVATION	MAXIMUM ELEVATION	COLOR
1	-4.41	-3.66	Red
2	-3.66	-2.82	Orange
3	-2.82	-2.04	Yellow
4	-2.04	-1.25	Light Green
5	-1.25	-0.44	Green
6	-0.44	0.35	Dark Green
7	0.35	1.15	Light Blue
8	1.15	1.94	Blue
9	1.94	2.73	Dark Blue
10	2.73	3.53	Purple

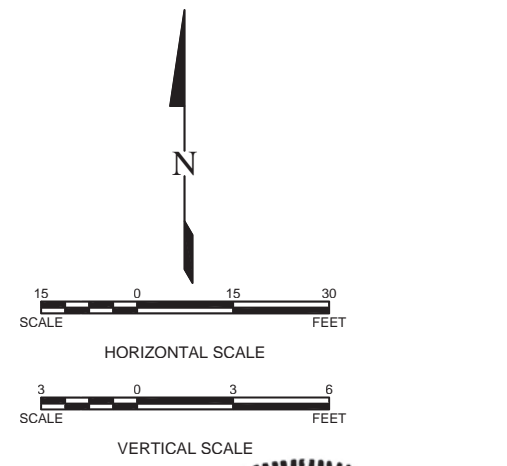
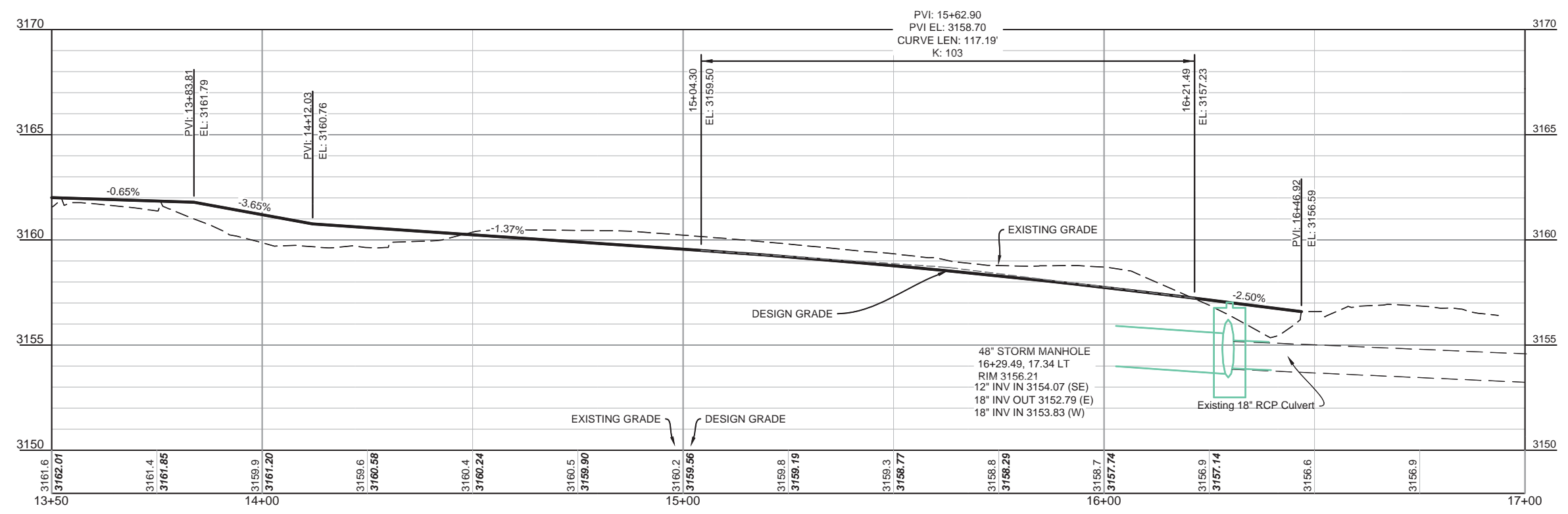

PLAN AND PROFILES

FOR BIDDING PURPOSES ONLY

SD DOT	PROJECT	SHEET	TOTAL SHEETS
	P TAPU(47)	29	112

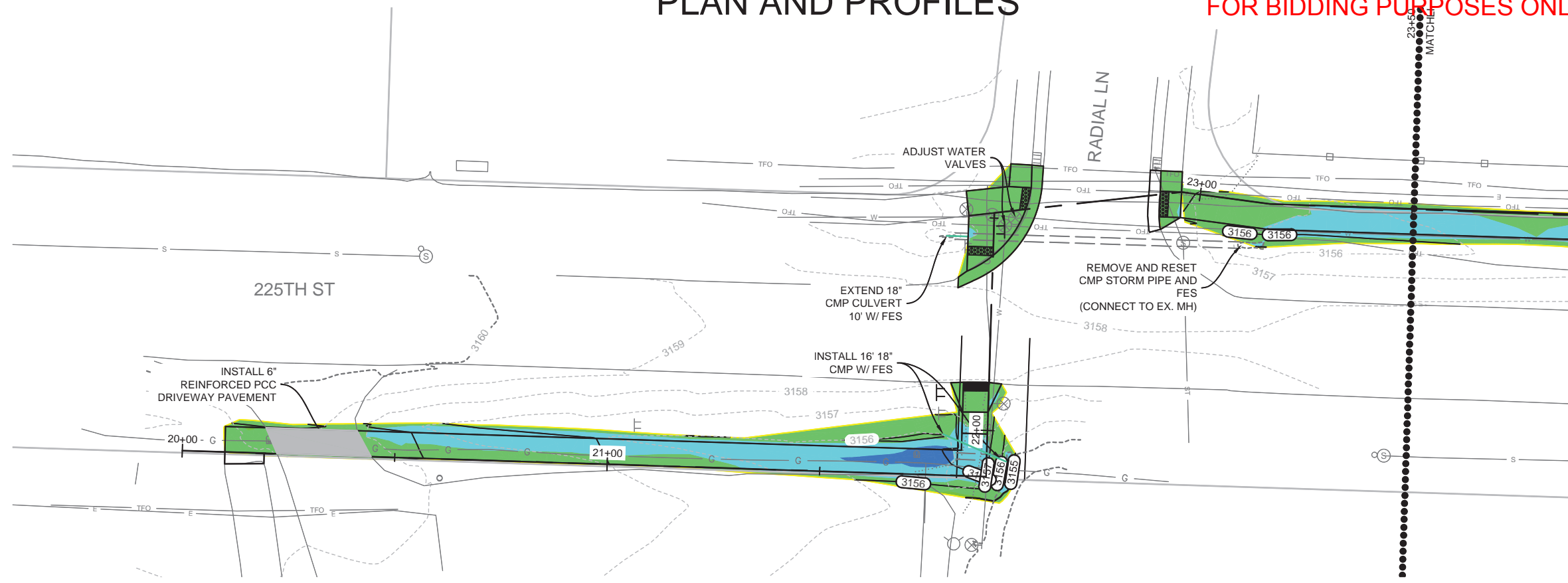

QUANTITIES THIS SHEET

4" CONCRETE SIDEWALK	1702 SF
6" REINFORCED PCC DRIVEWAY PAVEMENT	18 SY
TYPE B68 CONCRETE CURB AND GUTTER	52 LF
BASE COURSE	3 TON
GRAVEL CUSHION	32 TON
TYPE 1 DETECTABLE WARNINGS	48 SF
18" CMP	28 FT
18" CMP FLARED END	3 EA
CONNECT TO EXISTING MANHOLE	1 EA

SURFACE ELEVATION DATA

NUMBER	MINIMUM ELEVATION	MAXIMUM ELEVATION	COLOR
1	-4.41	-3.66	Red
2	-3.66	-2.82	Orange
3	-2.82	-2.04	Yellow
4	-2.04	-1.25	Light Green
5	-1.25	-0.44	Green
6	-0.44	0.35	Light Blue
7	0.35	1.15	Blue
8	1.15	1.94	Dark Blue
9	1.94	2.73	Purple
10	2.73	3.53	Dark Purple

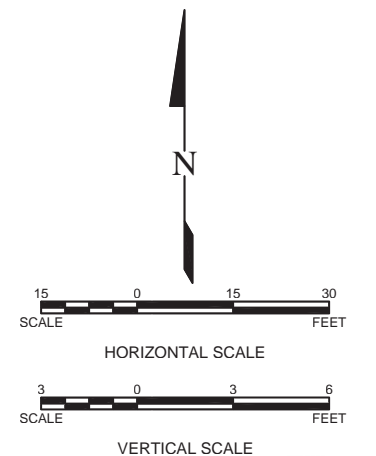
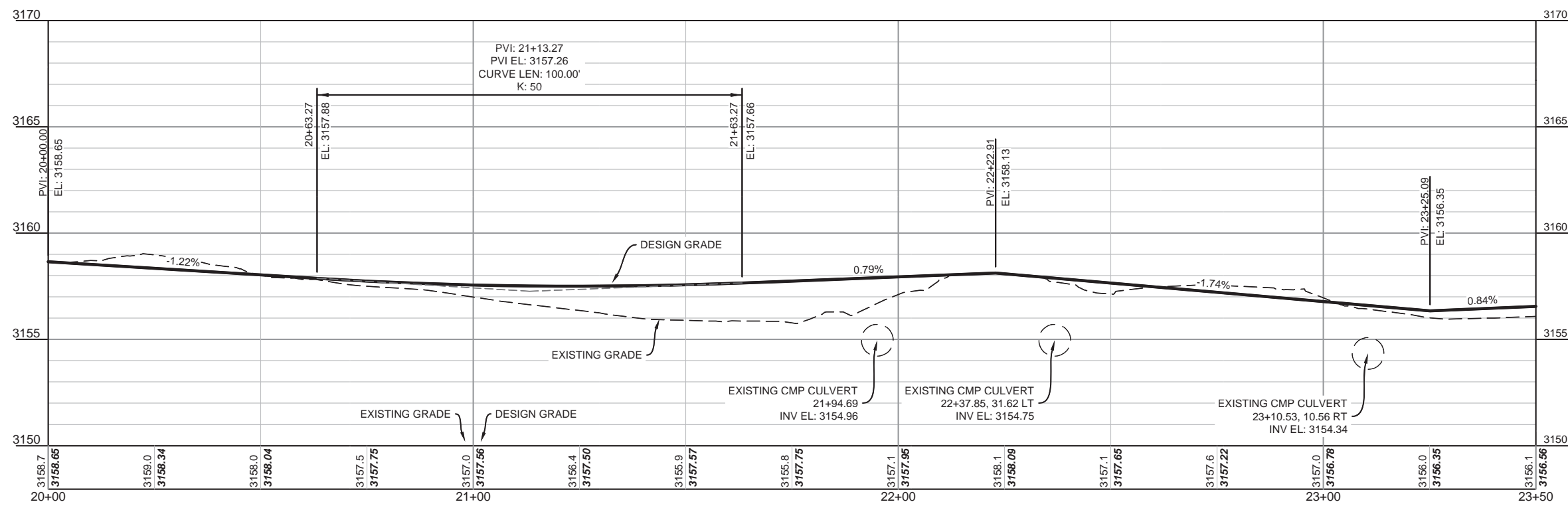

PLAN AND PROFILES

FOR BIDDING PURPOSES ONLY

SD DOT	PROJECT	SHEET	TOTAL SHEETS
	P TAPU(47)	30	112

QUANTITIES THIS SHEET

4" CONCRETE SIDEWALK	2100 SF
GRAVEL CUSHION	39 TON

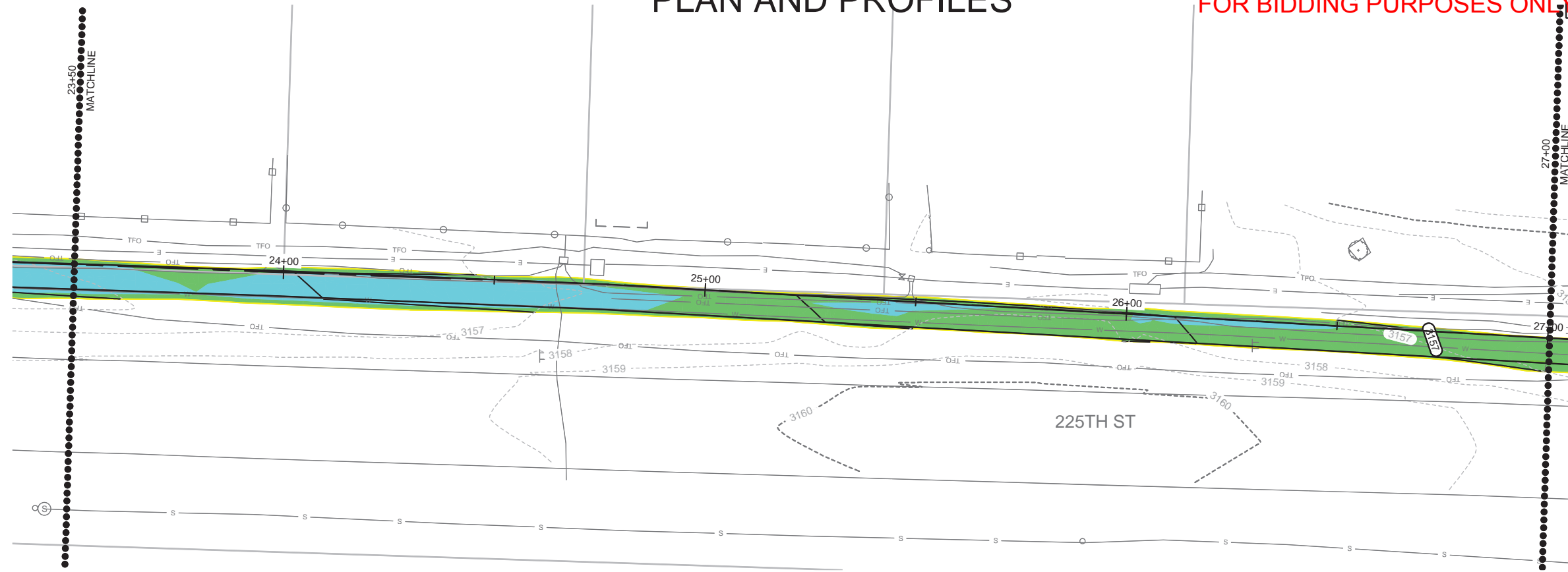

SURFACE ELEVATION DATA

NUMBER	MINIMUM ELEVATION	MAXIMUM ELEVATION	COLOR
1	-4.41	-3.66	Red
2	-3.66	-2.82	Orange
3	-2.82	-2.04	Yellow
4	-2.04	-1.25	Light Green
5	-1.25	-0.44	Green
6	-0.44	0.35	Light Blue
7	0.35	1.15	Blue
8	1.15	1.94	Dark Blue
9	1.94	2.73	Very Dark Blue
10	2.73	3.53	Purple

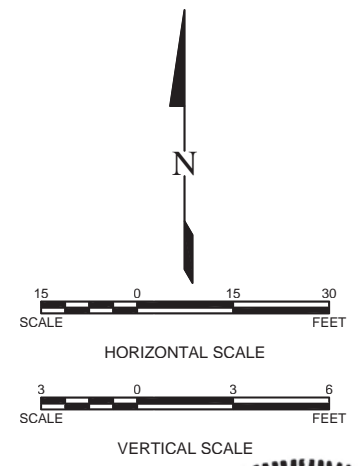
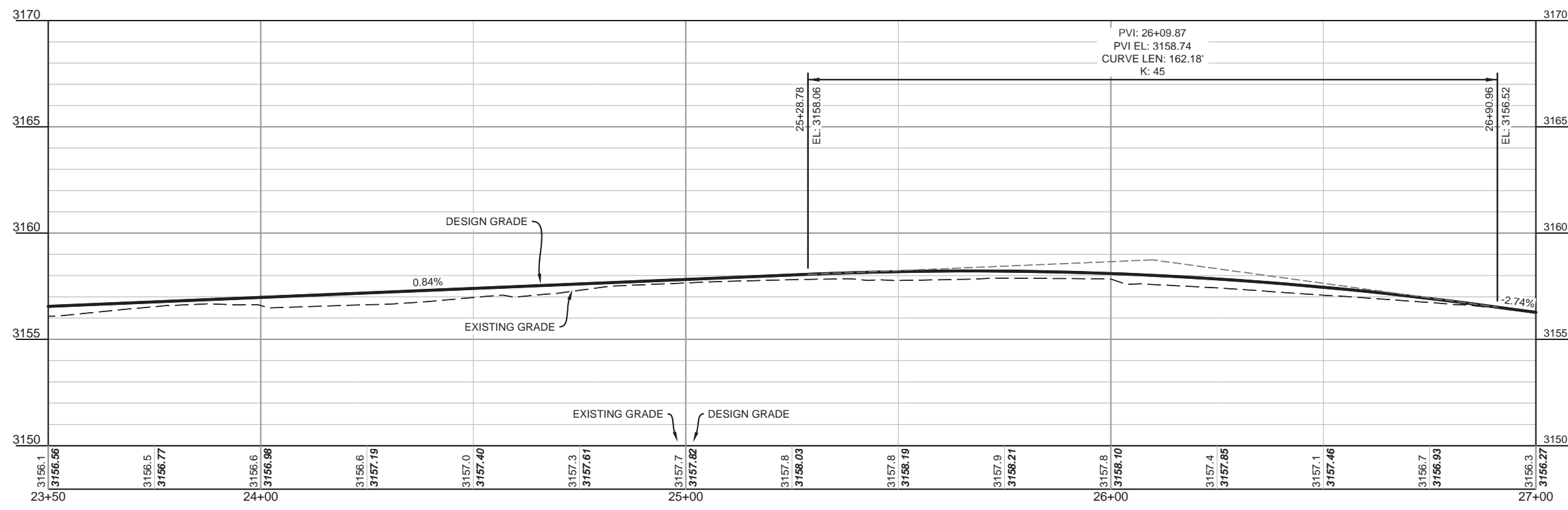

PLAN AND PROFILES

FOR BIDDING PURPOSES ONLY



PROJECT	SHEET	TOTAL SHEETS
P TAPU(47)	31	112

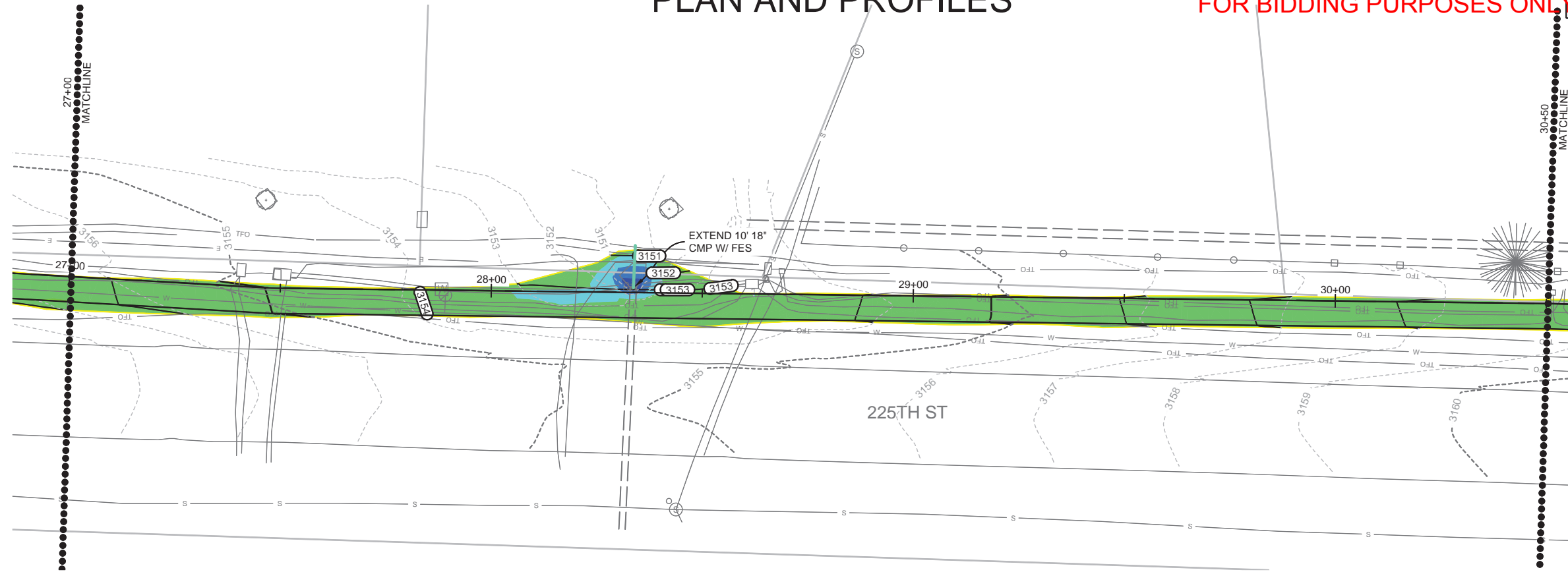

QUANTITIES THIS SHEET

4" CONCRETE SIDEWALK	2100 SF
GRAVEL CUSHION	39 TON
18" CMP	10 LF
18" CMP FES	1 EA

SURFACE ELEVATION DATA

NUMBER	MINIMUM ELEVATION	MAXIMUM ELEVATION	COLOR
1	-4.41	-3.66	Red
2	-3.66	-2.82	Orange
3	-2.82	-2.04	Yellow
4	-2.04	-1.25	Light Green
5	-1.25	-0.44	Green
6	-0.44	0.35	Light Blue
7	0.35	1.15	Blue
8	1.15	1.94	Dark Blue
9	1.94	2.73	Very Dark Blue
10	2.73	3.53	Purple

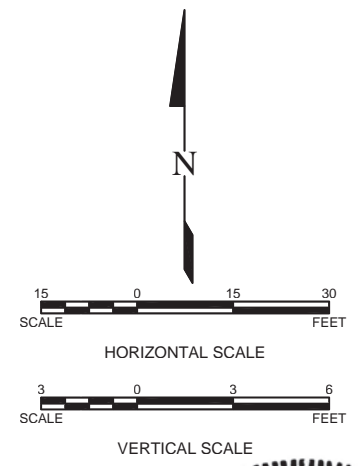
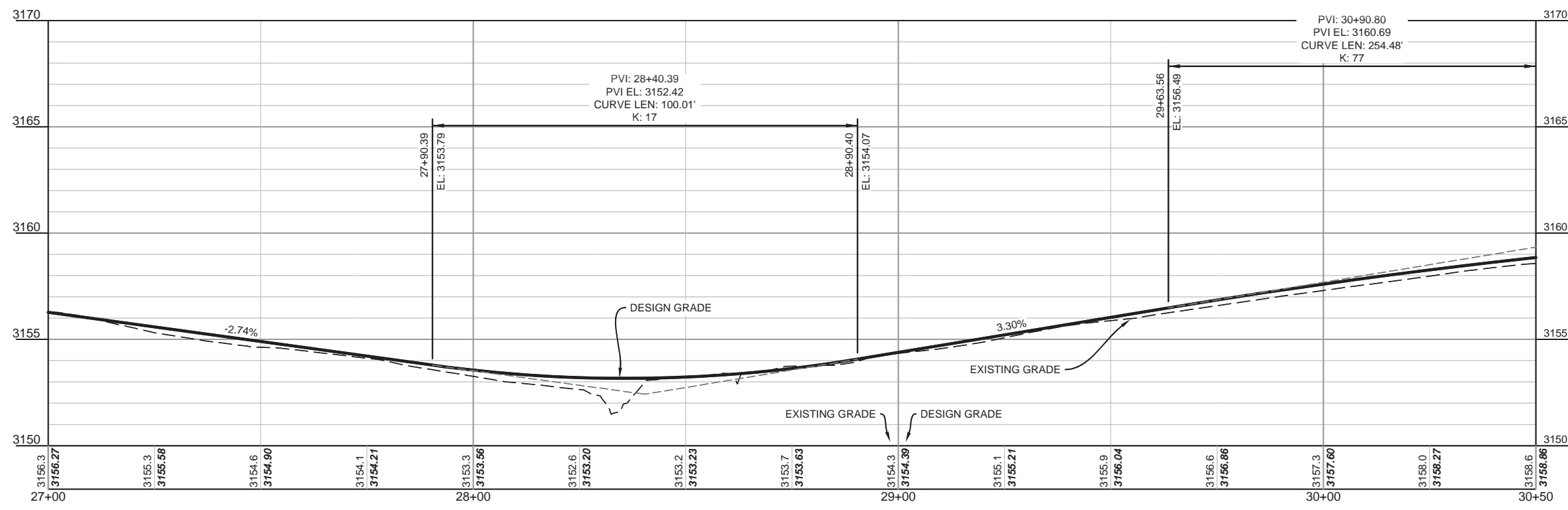

PLAN AND PROFILES

FOR BIDDING PURPOSES ONLY

SD DOT	PROJECT	SHEET	TOTAL SHEETS
	P TAPU(47)	32	112

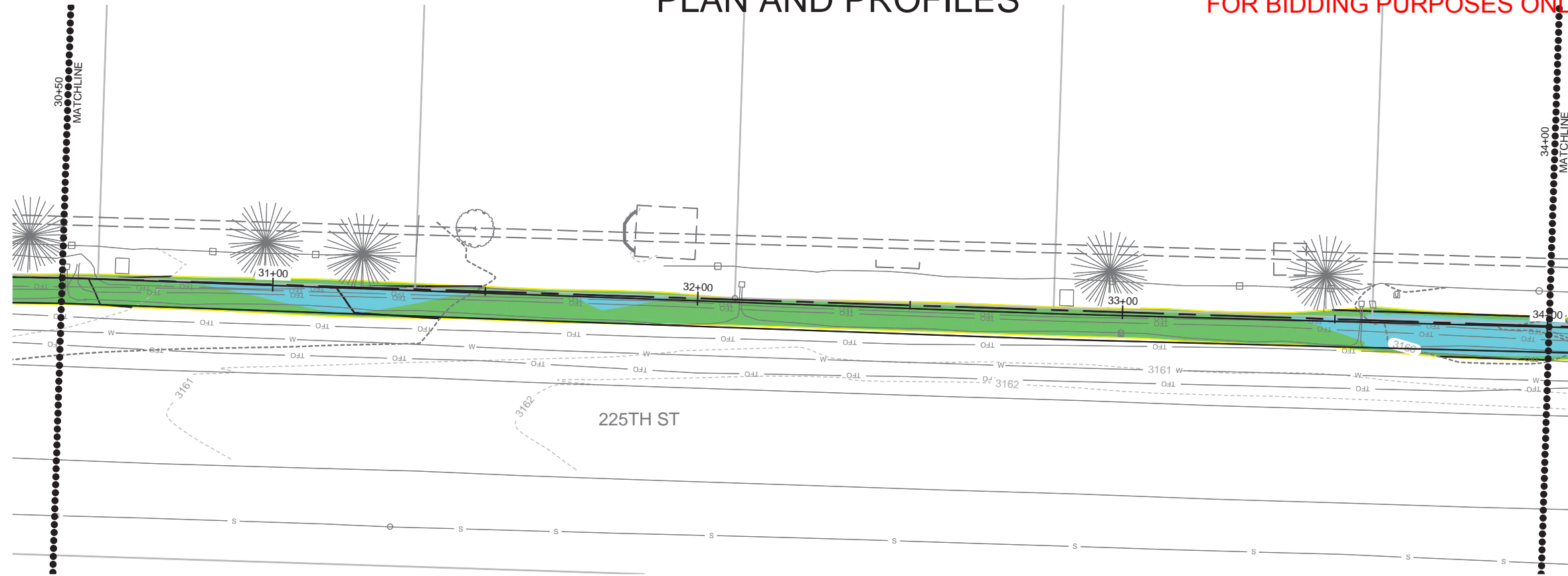

QUANTITIES THIS SHEET

4" CONCRETE SIDEWALK	2100 SF
GRAVEL CUSHION	39 TON

SURFACE ELEVATION DATA

NUMBER	MINIMUM ELEVATION	MAXIMUM ELEVATION	COLOR
1	-4.41	-3.66	Red
2	-3.66	-2.82	Orange
3	-2.82	-2.04	Yellow
4	-2.04	-1.25	Light Green
5	-1.25	-0.44	Green
6	-0.44	0.35	Light Blue
7	0.35	1.15	Blue
8	1.15	1.94	Dark Blue
9	1.94	2.73	Very Dark Blue
10	2.73	3.53	Purple

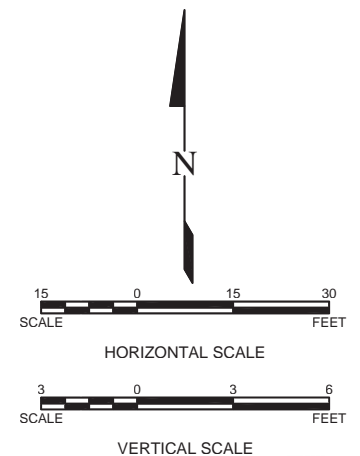
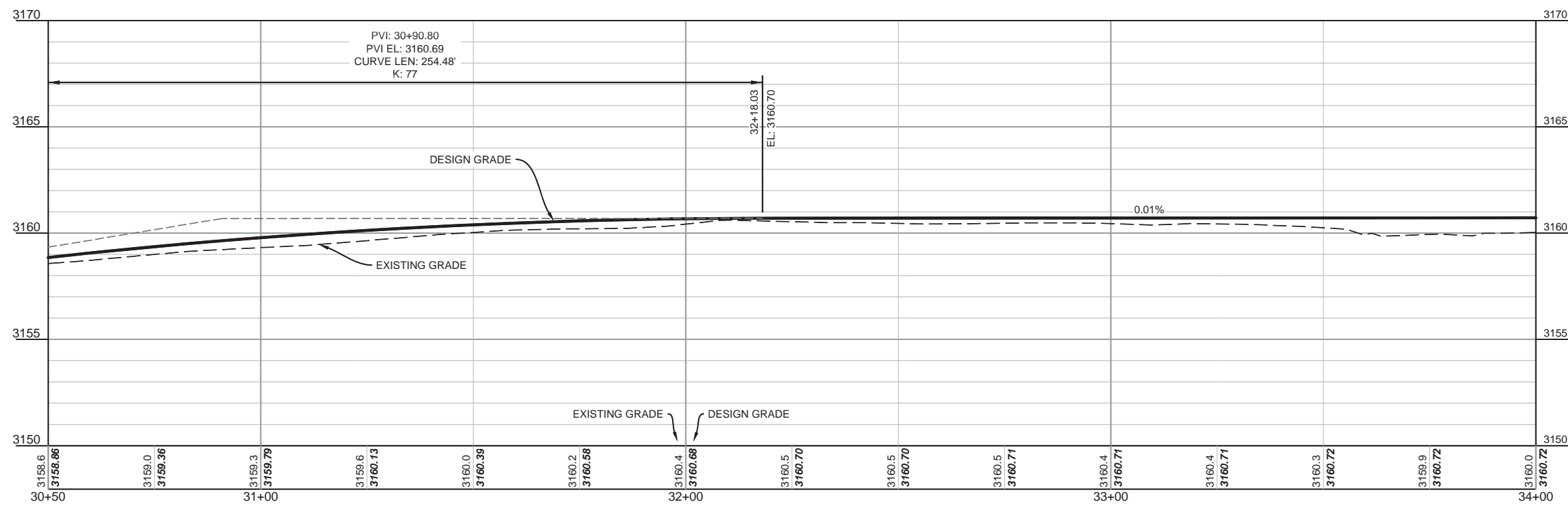

PLAN AND PROFILES

FOR BIDDING PURPOSES ONLY

PROJECT	SHEET	TOTAL SHEETS
	P TAPU(47)	33 / 112

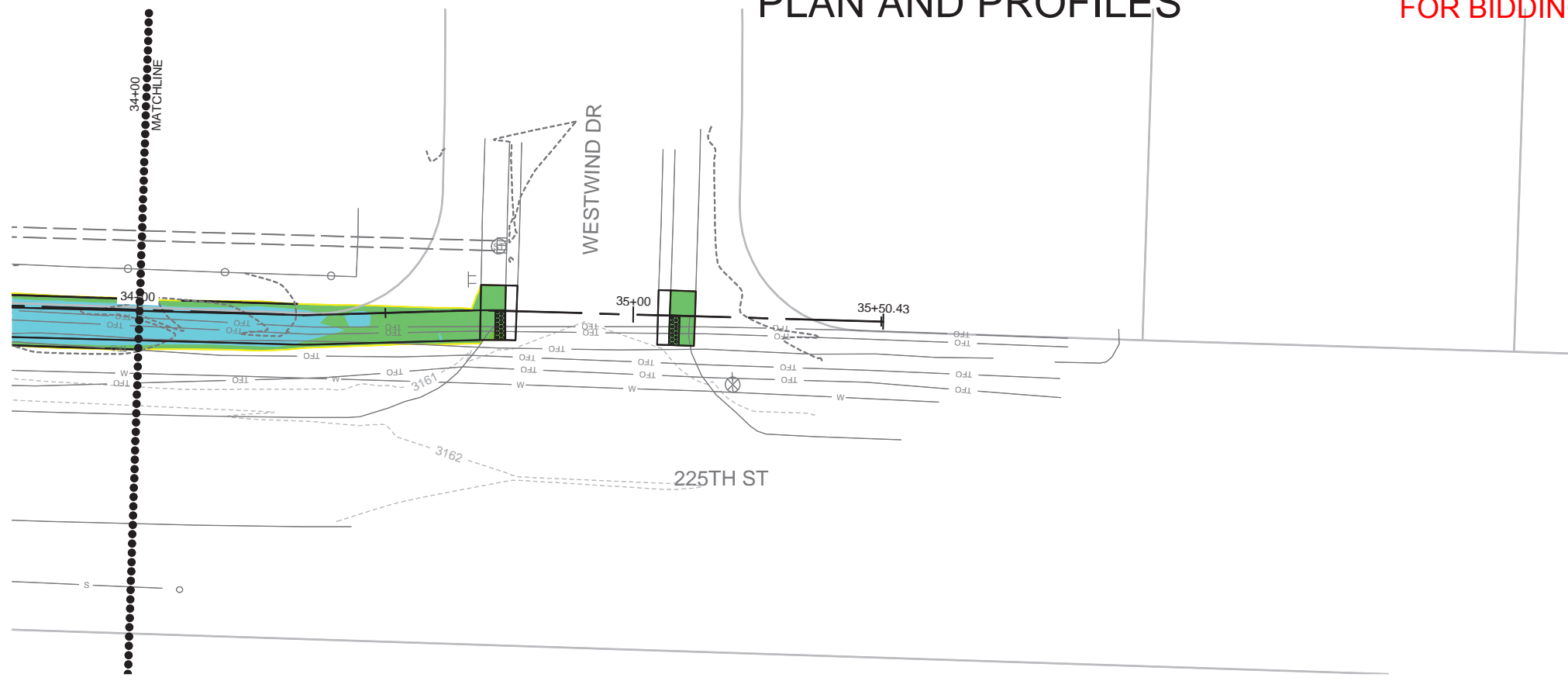

QUANTITIES THIS SHEET

4" CONCRETE SIDEWALK	521 SF
TYPE B68 CONCRETE CURB AND GUTTER	22 LF
BASE COURSE	1 TON
GRAVEL CUSHION	10 TON
TYPE 1 DETECTABLE WARNINGS	24 SF

SURFACE ELEVATION DATA

NUMBER	MINIMUM ELEVATION	MAXIMUM ELEVATION	COLOR
1	-4.41	-3.66	Red
2	-3.66	-2.82	Orange
3	-2.82	-2.04	Yellow
4	-2.04	-1.25	Light Green
5	-1.25	-0.44	Green
6	-0.44	0.35	Light Blue
7	0.35	1.15	Blue
8	1.15	1.94	Dark Blue
9	1.94	2.73	Very Dark Blue
10	2.73	3.53	Purple

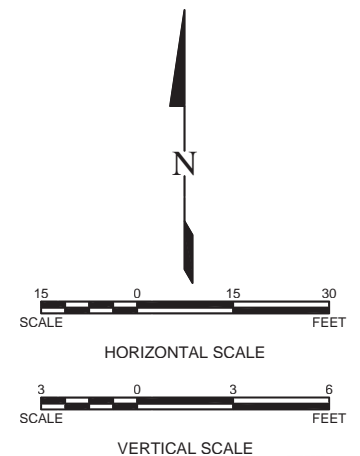
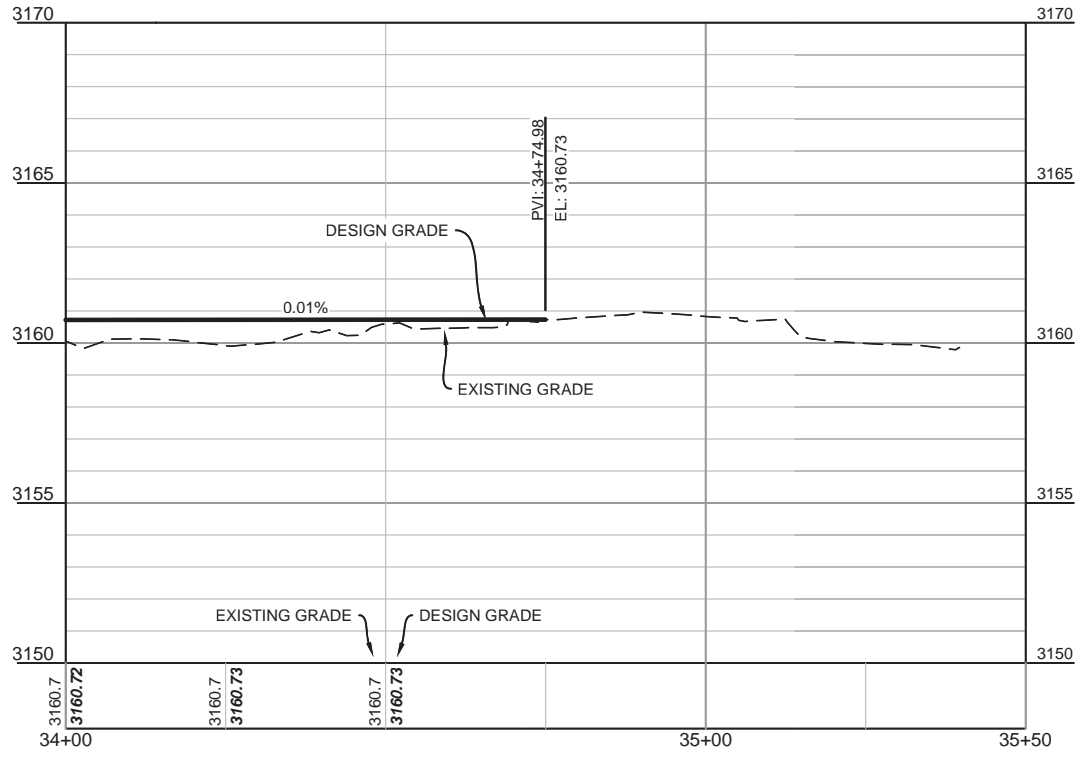

PLAN AND PROFILES

FOR BIDDING PURPOSES ONLY

SD DOT	PROJECT	SHEET	TOTAL SHEETS
	P TAPU(47)	34	112

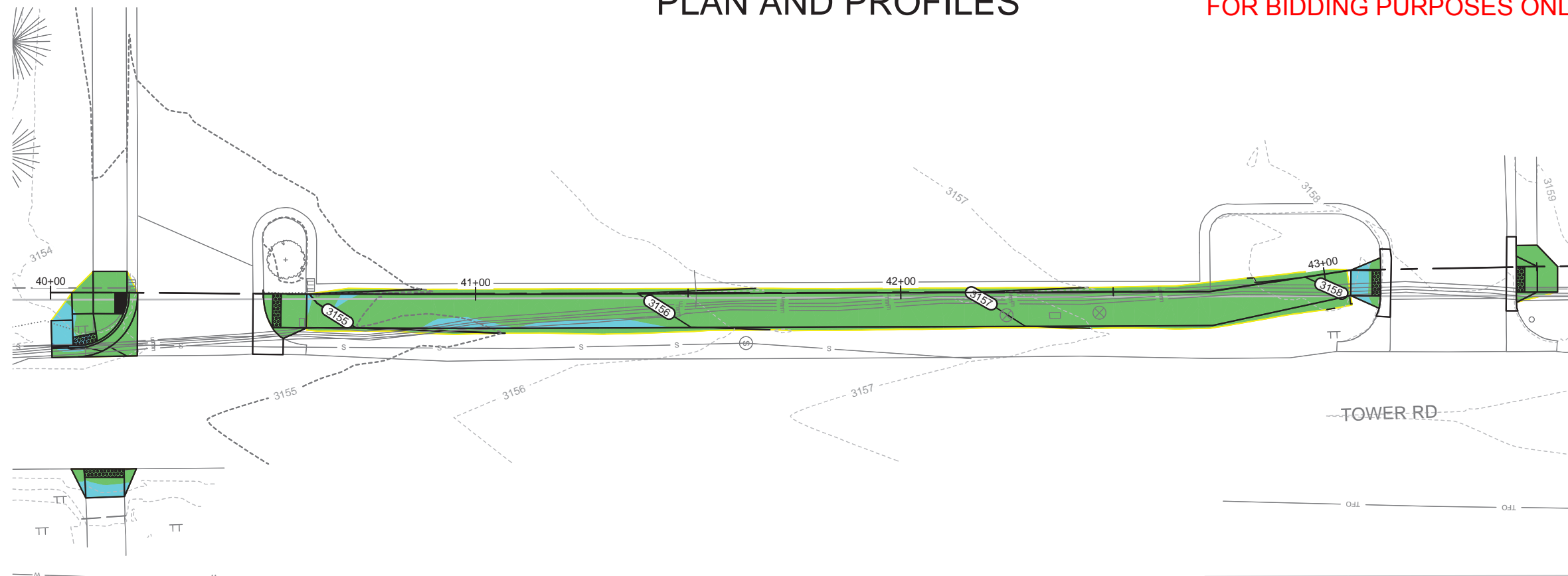

QUANTITIES THIS SHEET

4" CONCRETE SIDEWALK	2466 SF
TYPE B68 CONCRETE CURB AND GUTTER	61 LF
BASE COURSE	5 TON
GRAVEL CUSHION	45 TON
TYPE 1 DETECTABLE WARNINGS	83 SF
6" PCC FILLET SECTION	19 SY

SURFACE ELEVATION DATA

NUMBER	MINIMUM ELEVATION	MAXIMUM ELEVATION	COLOR
1	-4.41	-3.66	Red
2	-3.66	-2.82	Orange
3	-2.82	-2.04	Yellow
4	-2.04	-1.25	Light Green
5	-1.25	-0.44	Green
6	-0.44	0.35	Light Blue
7	0.35	1.15	Blue
8	1.15	1.94	Dark Blue
9	1.94	2.73	Very Dark Blue
10	2.73	3.53	Purple

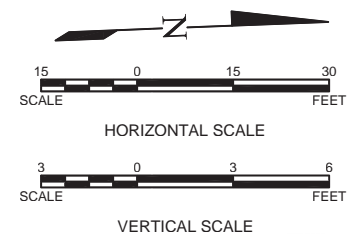
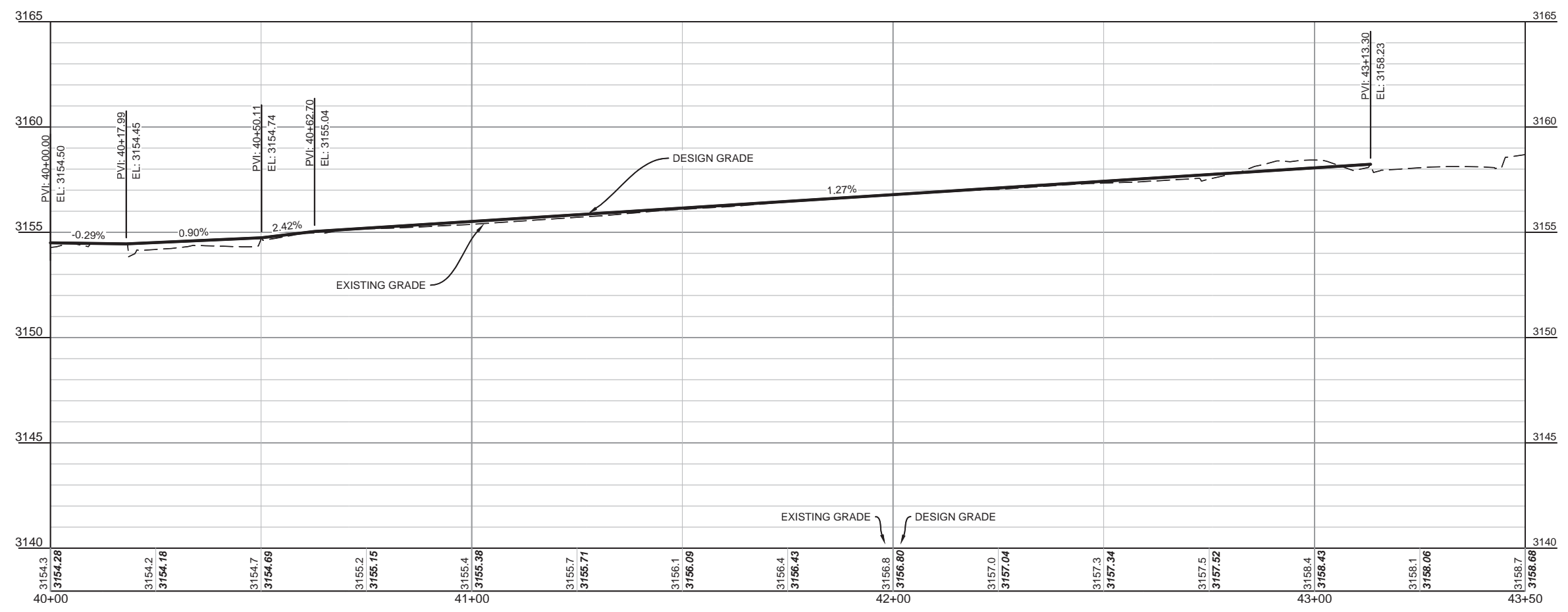



RIGHT-OF-WAY & EASEMENT OWNERSHIP TABLE					
PARCEL NUMBER	TYPE	PURPOSE	AREA REQUIRED (SF)	OWNER	LEGAL DESCRIPTION
1	TEMP	SIDEWALK	13087	DOUGLAS SCHOOL DISTRICT #1	UNPLATTED PORTION OF NE 1/4 NW 1/4 INCLUDING THAT PT VACATED DON WILLIAMS DR ROW ADJ SAID LOT
2	TEMP	SIDEWALK	102	JAENNIS LLC	PT LOT S OF LOT XY LESS PT OF LOT B, LESS LOT C, AND LESS ROW
3	TEMP	SIDEWALK	1731	LSPS LLC	LOT 1
4	TEMP	SIDEWALK	339	GLADE WESTWOOD	LOT 1

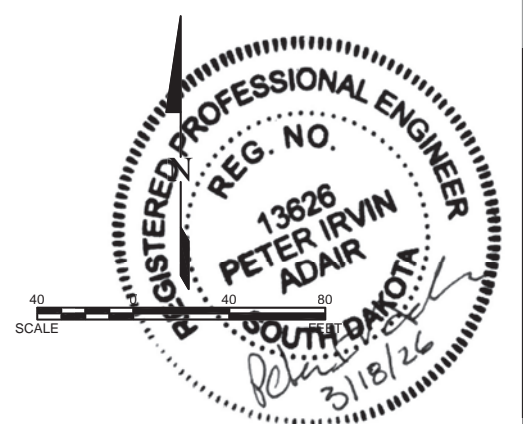

SCALE 40 80



PROJECT	SHEET	TOTAL SHEETS
P TAPU(47)	36	112

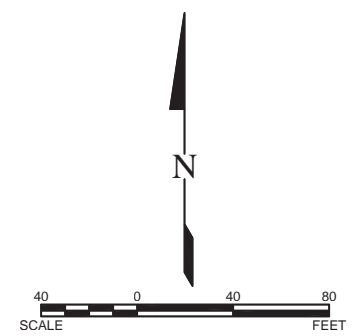
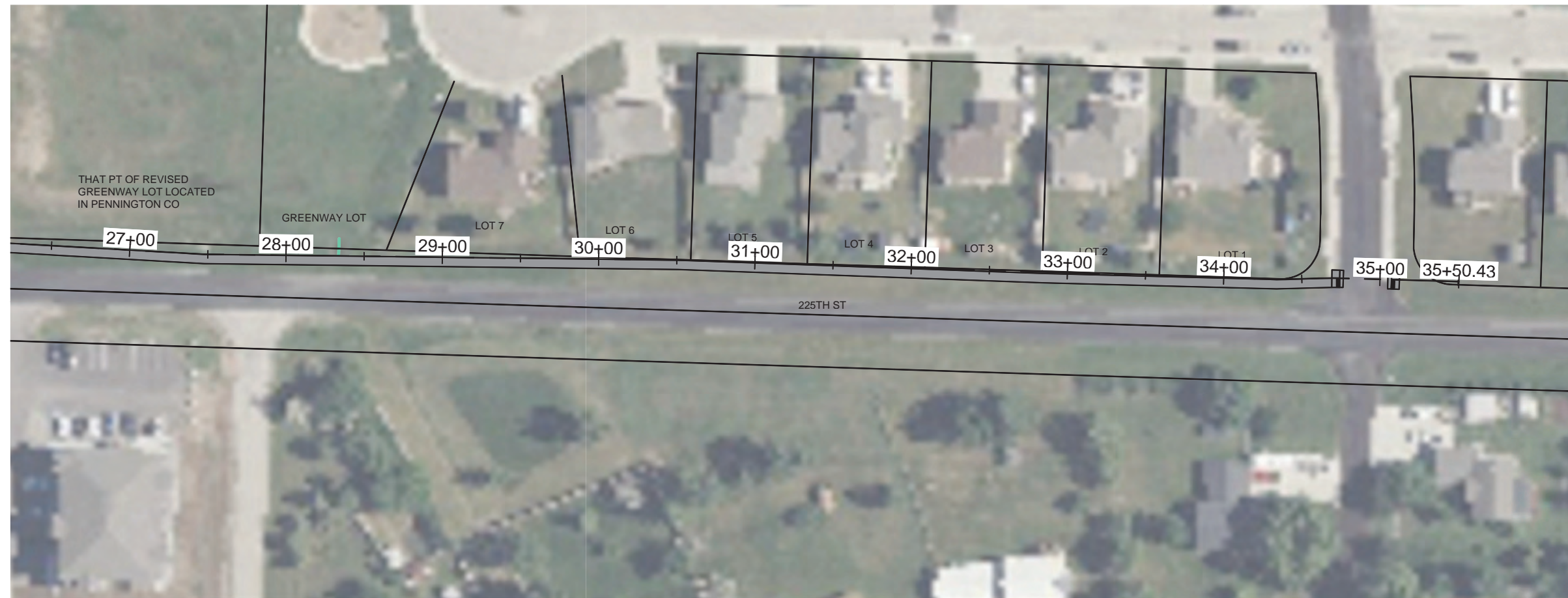

	PROJECT	SHEET	TOTAL SHEETS
	P TAPU(47)	37	112

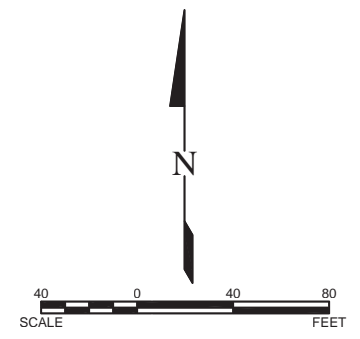
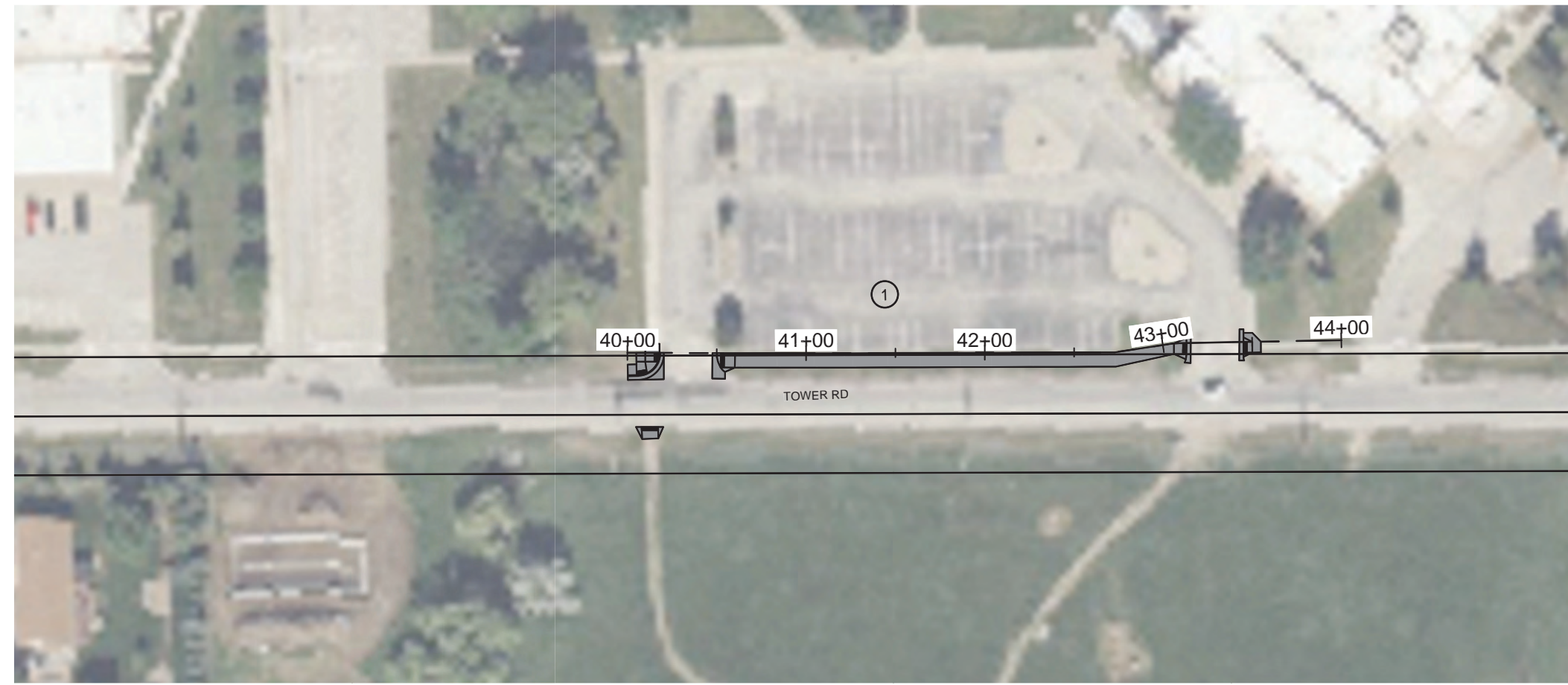

FOR BIDDING PURPOSES ONLY



PROJECT	SHEET	TOTAL SHEETS
P TAPU(47)	38	112

REMOVALS

QUANTITIES THIS SHEET

REMOVE CONCRETE SIDEWALK	32 SY
ADJUST WATER VALVE BOX	2 EA
REMOVE SIGN FOR RESET	2 EA
REMOVE TYPE B68 CONCRETE CURB AND GUTTER	97 LF
CLEARING	734 SY

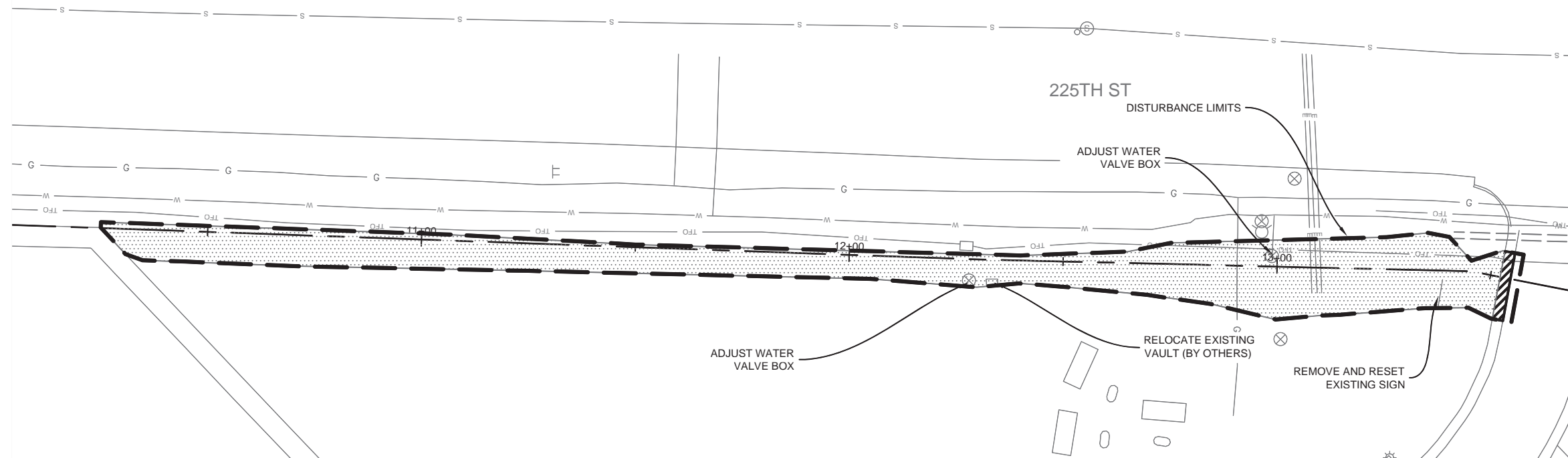

- REMOVE TOPSOIL
- REMOVE ASPHALT
- REMOVE CURB & GUTTER
- REMOVE GRAVEL SURFACING
- REMOVE SIDEWALK

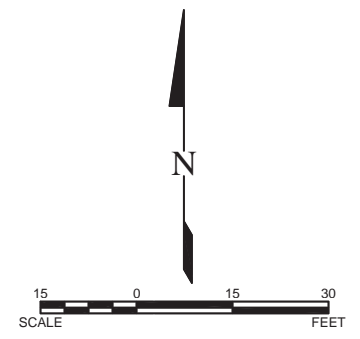
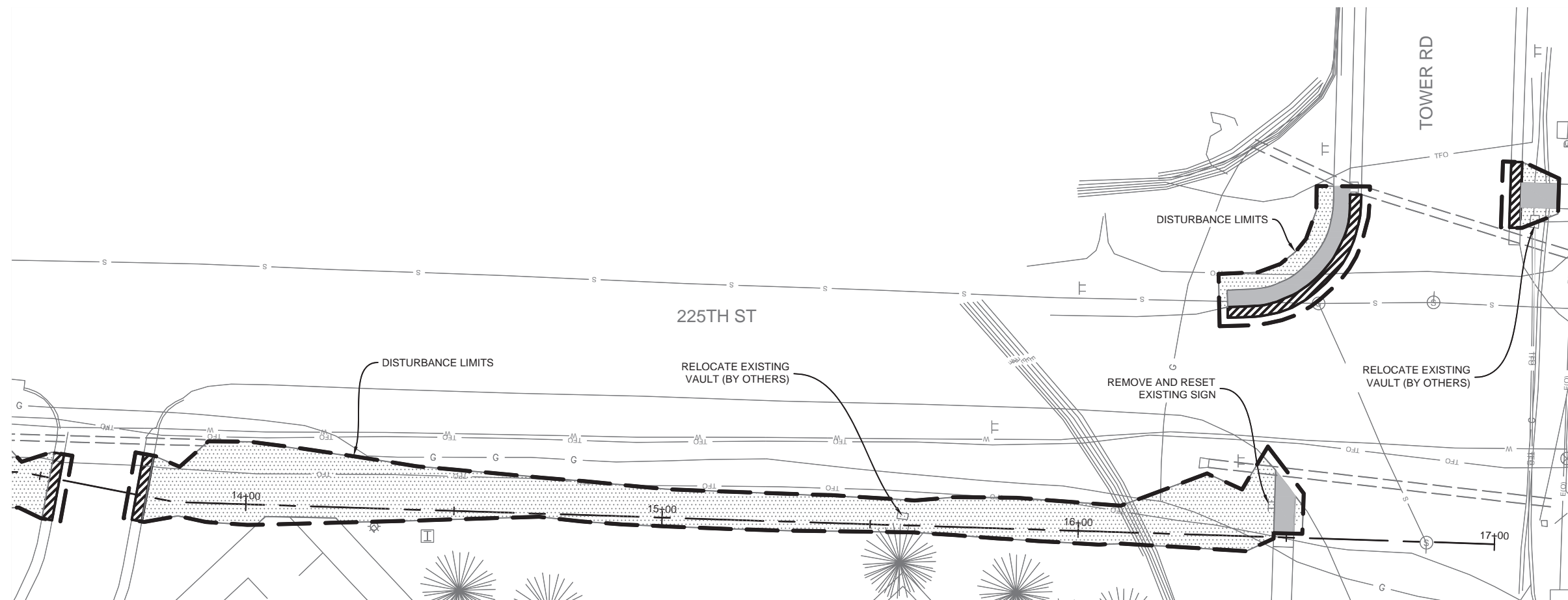

FOR BIDDING PURPOSES ONLY



PROJECT	SHEET	TOTAL SHEETS
P TAPU(47)	39	112

REMOVALS

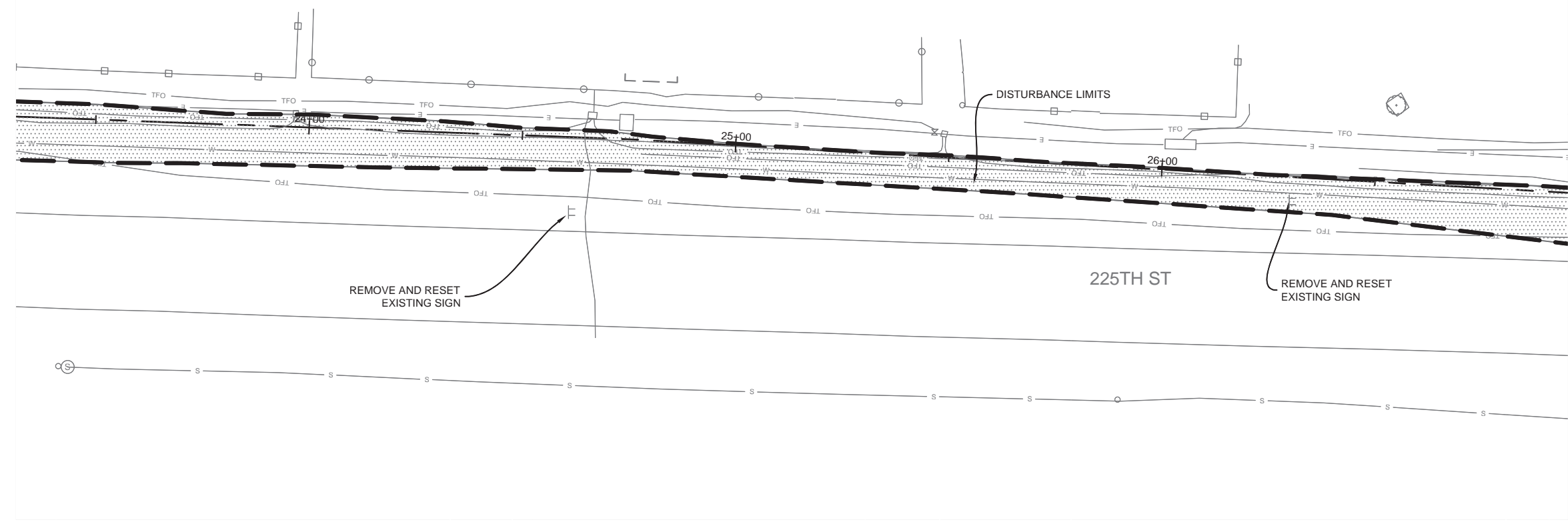
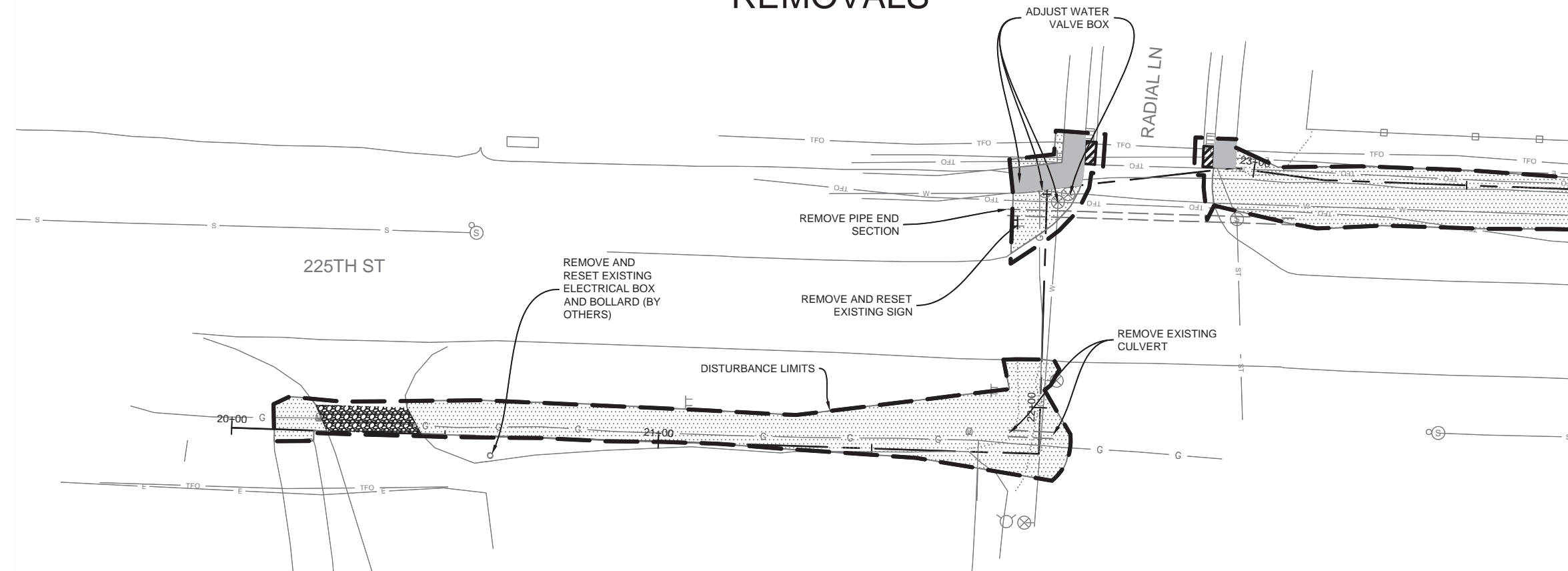

QUANTITIES THIS SHEET

REMOVE GRANULAR MATERIAL	2 CY
REMOVE CONCRETE SIDEWALK	19 SY
REMOVE SIGN FOR RESET	3 EA
REMOVE PIPE END SECTION	1 EA
ADJUST WATER VALVE BOX	4 EA
REMOVE TYPE B68 CONCRETE CURB AND GUTTER	10 LF
CLEARING	380 SY
REMOVE EXISTING CULVERT	10 LF

- REMOVE TOPSOIL
- REMOVE ASPHALT
- REMOVE CURB & GUTTER
- REMOVE GRAVEL SURFACING
- REMOVE SIDEWALK

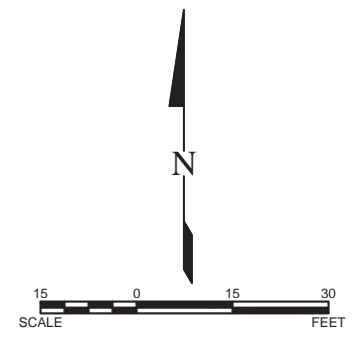

FOR BIDDING PURPOSES ONLY



PROJECT	SHEET	TOTAL SHEETS
P TAPU(47)	40	112

REMOVALS

QUANTITIES THIS SHEET

REMOVE SIGN FOR RESET	1 EA
CLEARING	601 SY
ADJUST EXISTING WATER VALVE	1 EA

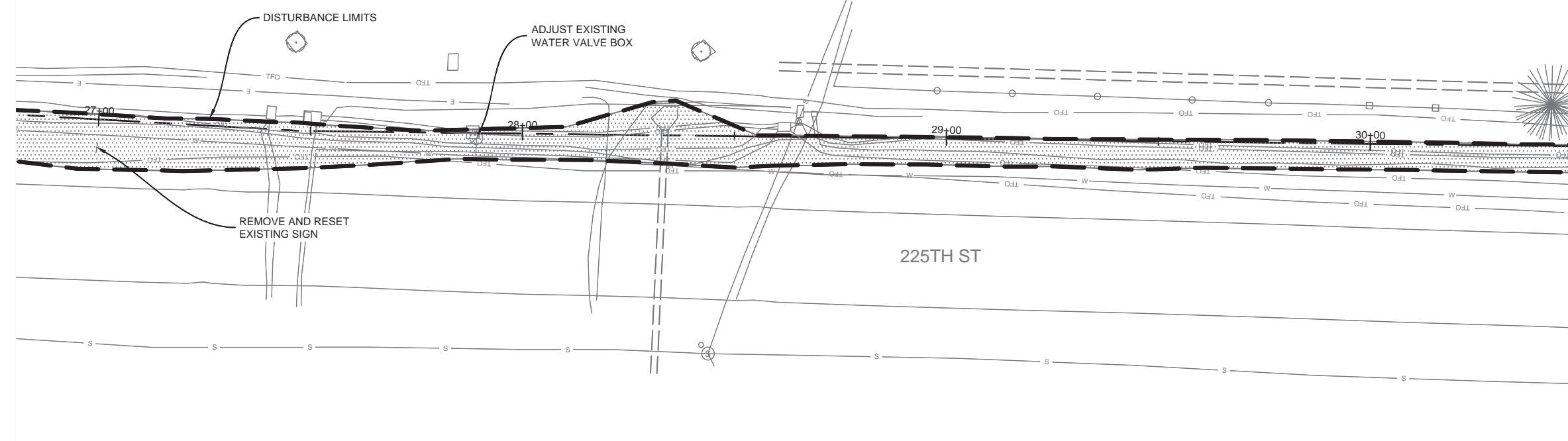

- REMOVE TOPSOIL
- REMOVE ASPHALT
- REMOVE CURB & GUTTER
- REMOVE GRAVEL SURFACING
- REMOVE SIDEWALK

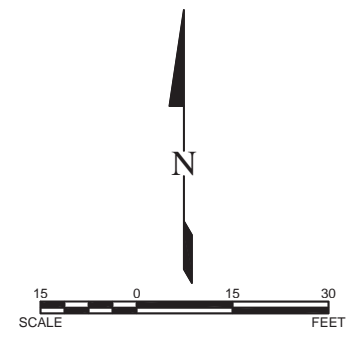
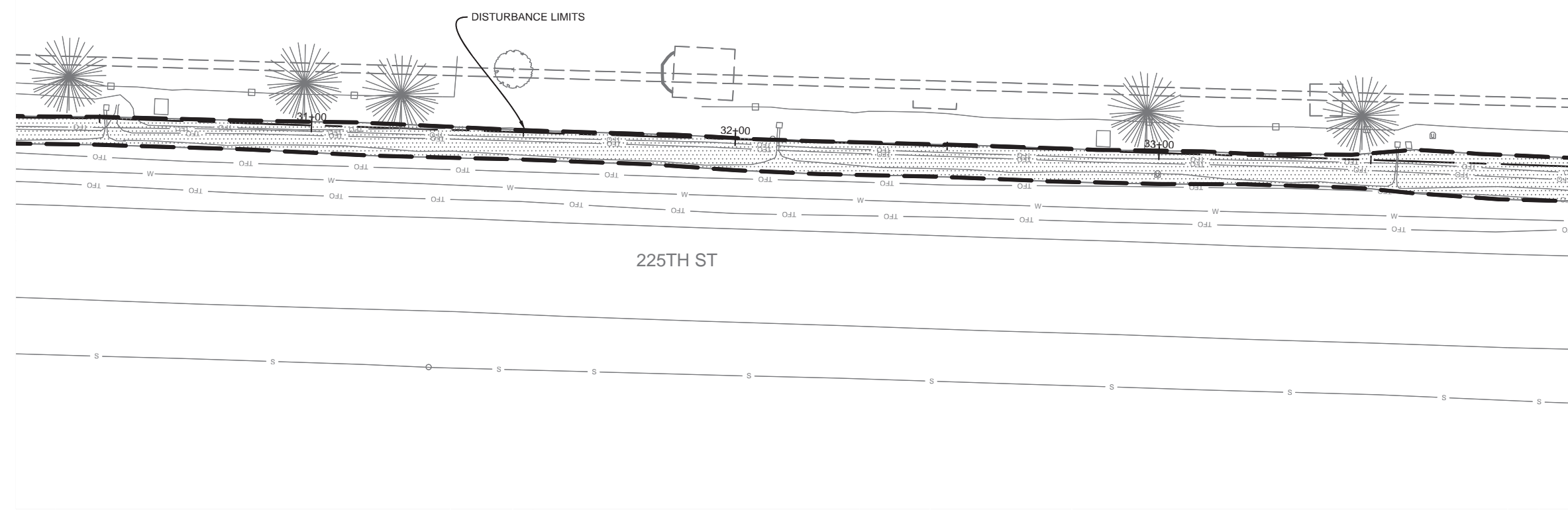

FOR BIDDING PURPOSES ONLY



PROJECT	SHEET	TOTAL SHEETS
P TAPU(47)	41	112

REMOVALS

QUANTITIES THIS SHEET

REMOVE ASPHALT CONCRETE PAVEMENT	7 SY
REMOVE CONCRETE SIDEWALK	8 SY
REMOVE TYPE B68 CONCRETE CURB AND GUTTER	14 LF
CLEARING	209 SY
REMOVE SIGN FOR RESET	1 EA

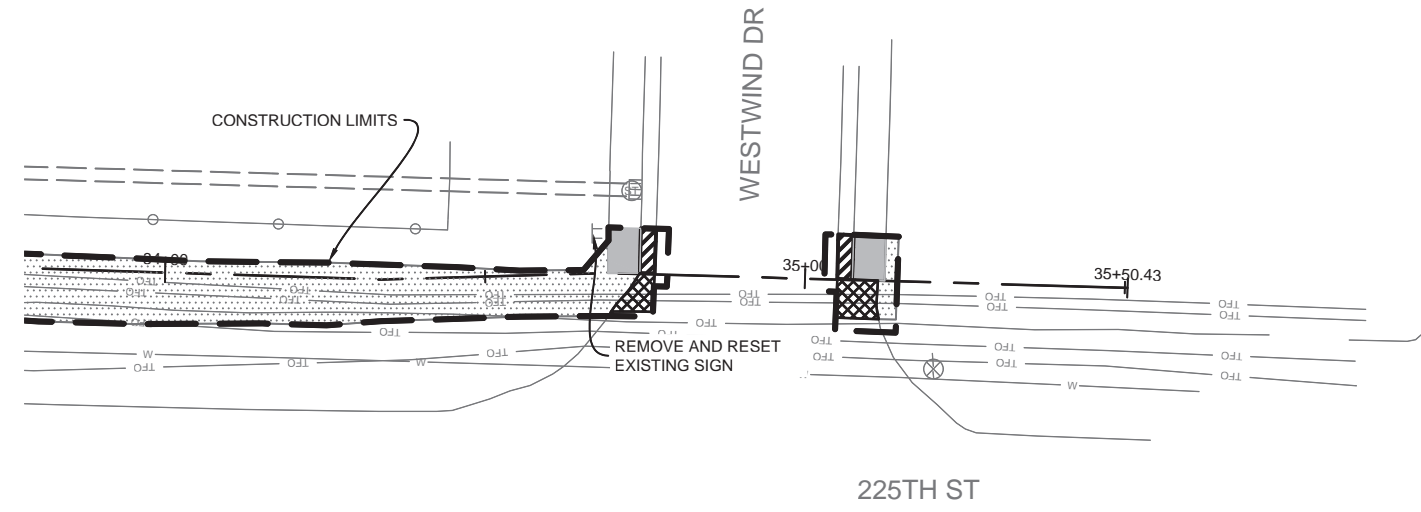

-  REMOVE TOPSOIL
-  REMOVE ASPHALT
-  REMOVE CURB & GUTTER
-  REMOVE GRAVEL SURFACING
-  REMOVE SIDEWALK

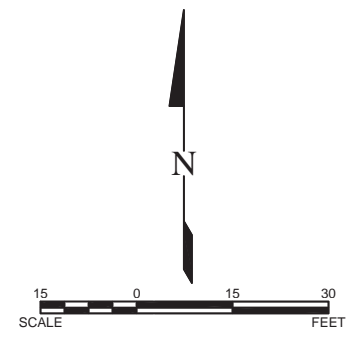

FOR BIDDING PURPOSES ONLY



PROJECT	SHEET	TOTAL SHEETS
P TAPU(47)	42	112

REMOVALS

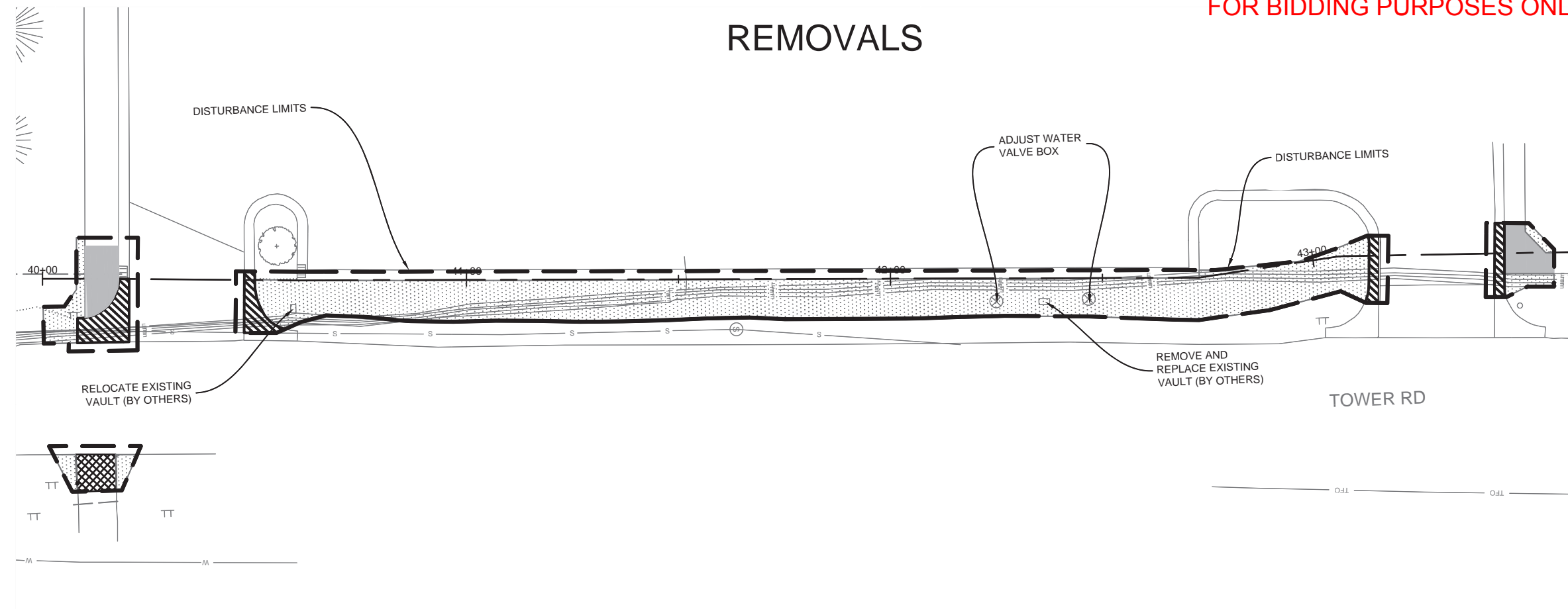

QUANTITIES THIS SHEET

REMOVE ASPHALT CONCRETE PAVEMENT	9 SY
REMOVE CONCRETE SIDEWALK	25 SY
ADJUST WATER VALVE BOX	2 EA
REMOVE TYPE B68 CONCRETE CURB AND GUTTER	32 LF
CLEARING	416 SY
REMOVE 6" PCC FILLET SECTION	19 SY

- REMOVE TOPSOIL
- REMOVE ASPHALT
- REMOVE CURB & GUTTER
- REMOVE GRAVEL SURFACING
- REMOVE SIDEWALK

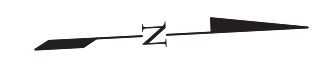

ADA CURB RAMP LAYOUT

FOR BIDDING PURPOSES ONLY

	PROJECT	SHEET	TOTAL SHEETS
	P TAPU(47)	43	112

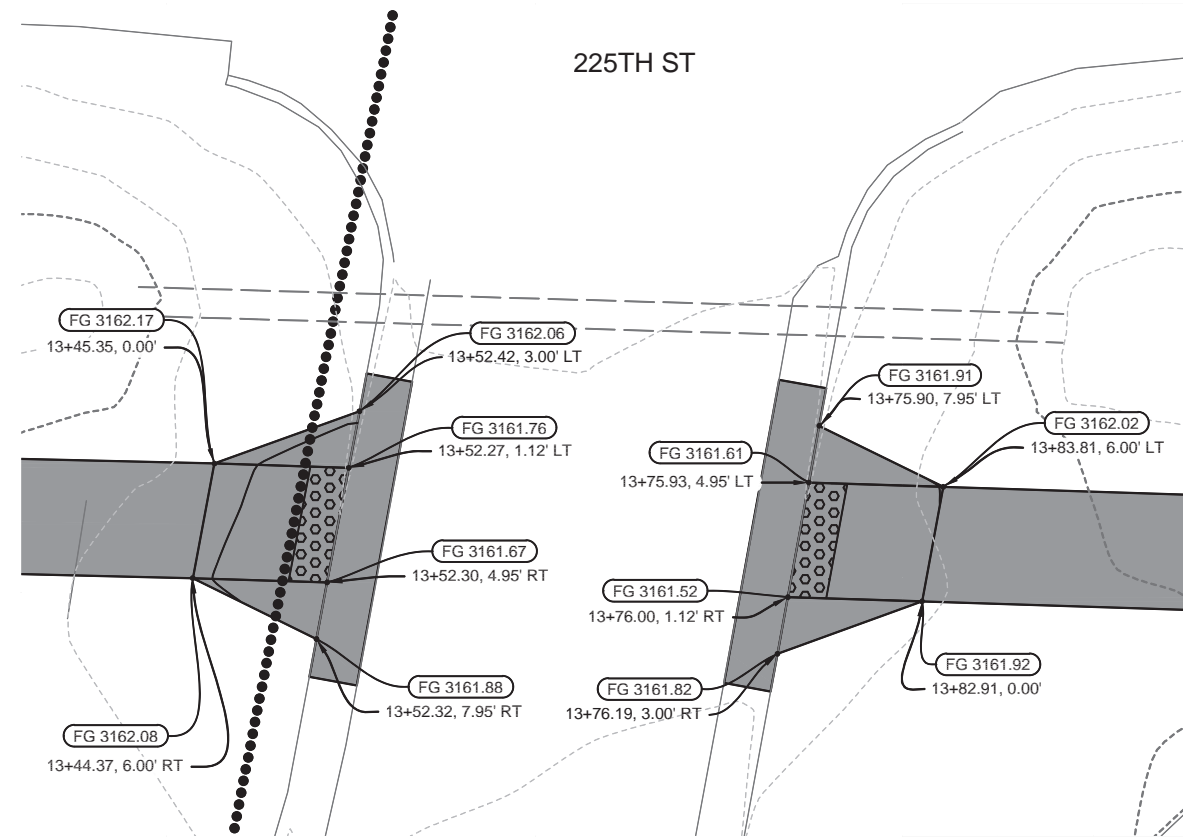

NORTH SIDE SCHOOL MAINTENANCE ENTRANCE & 225TH ST

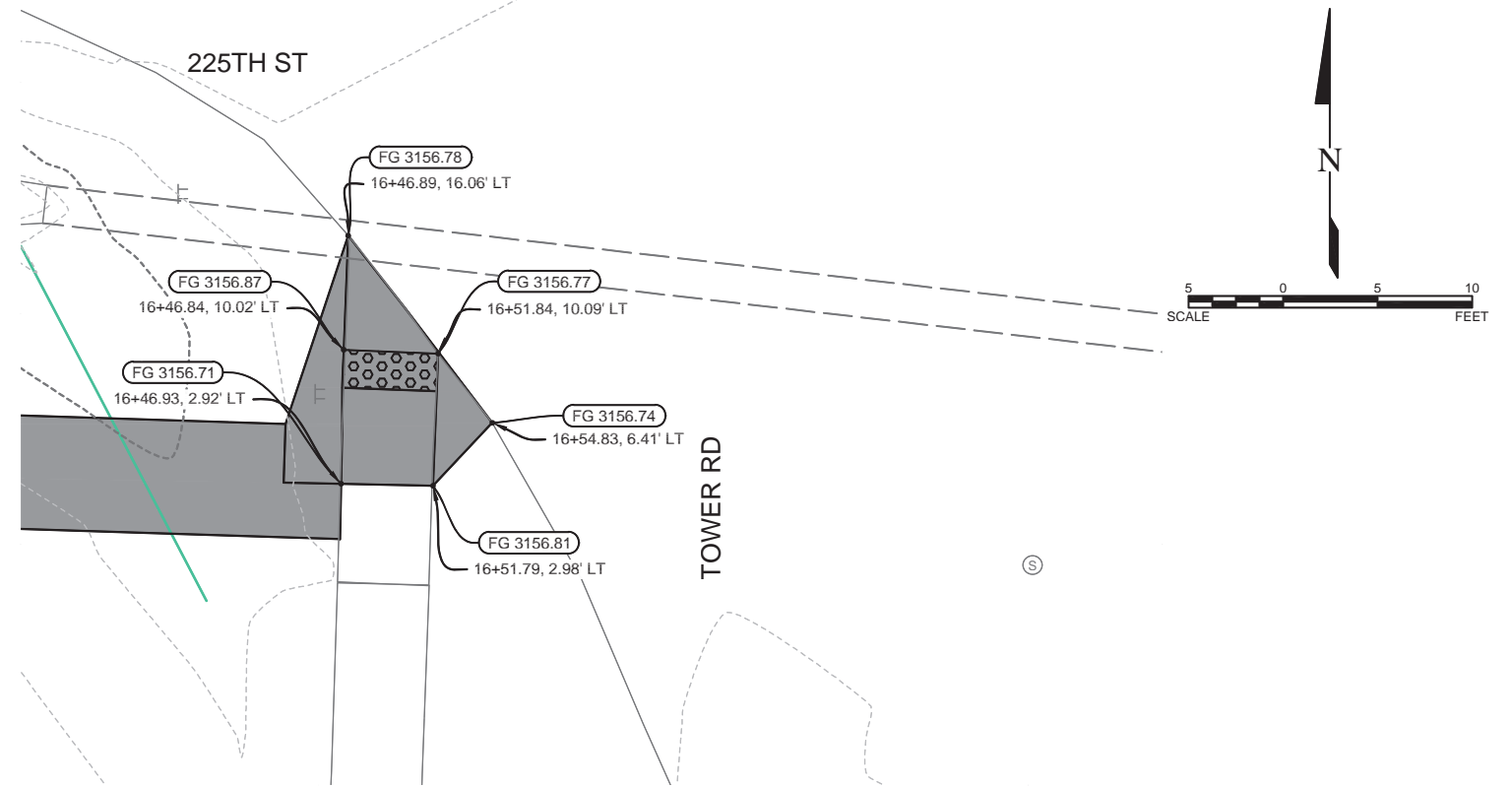

SW QUADRANT TOWER RD & 225TH ST

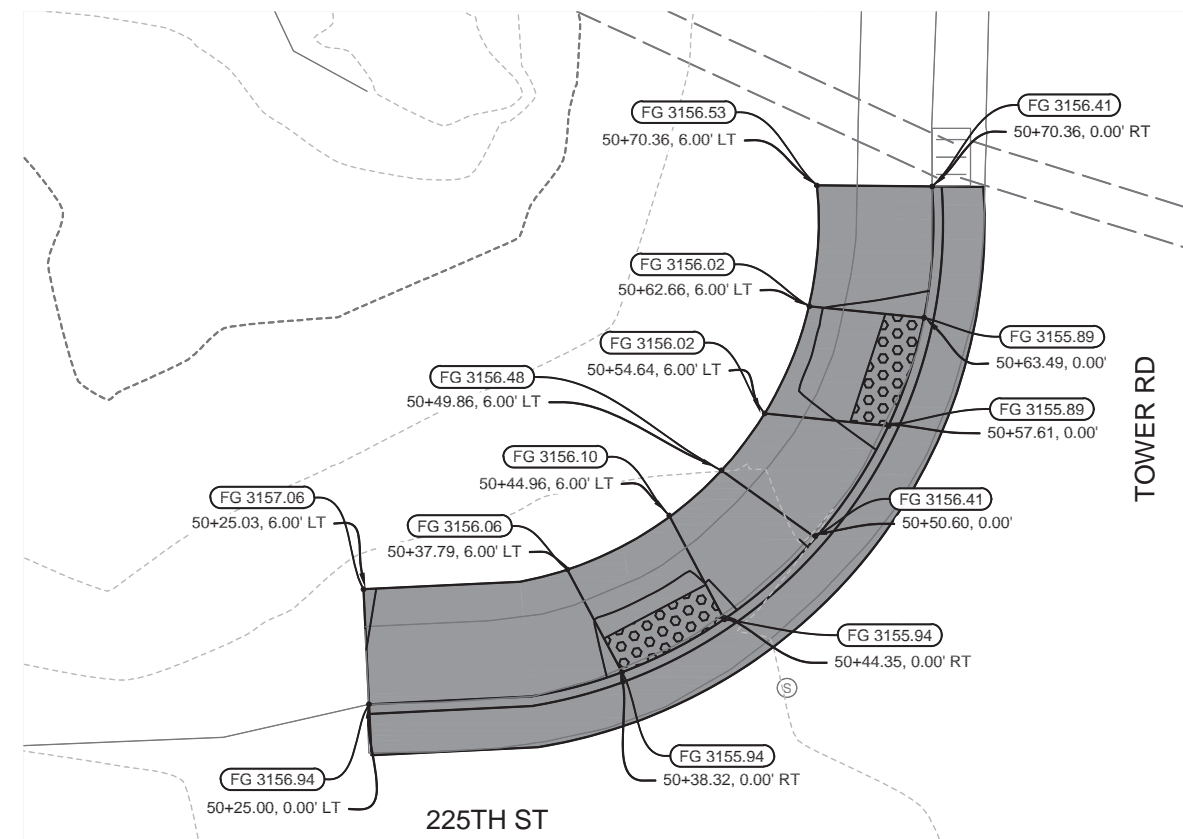

NW QUADRANT TOWER RD & 225TH ST

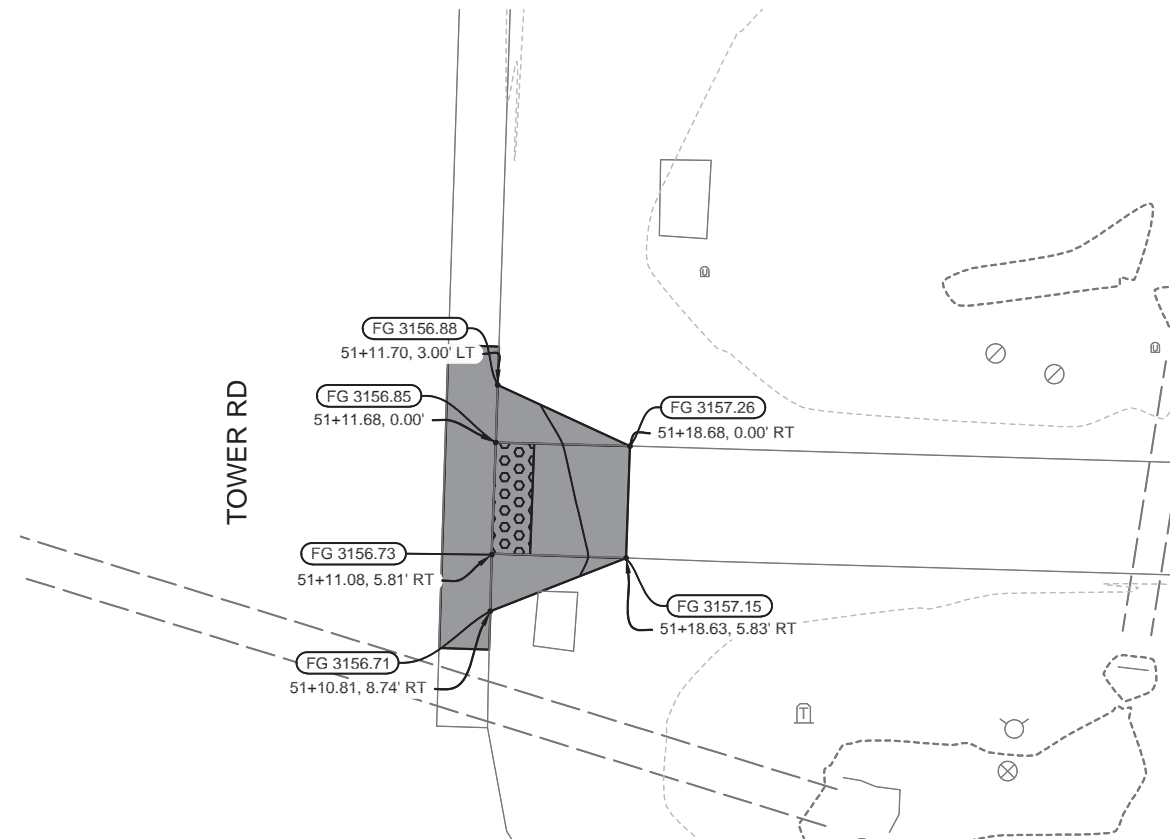

NE QUADRANT TOWER RD & 225TH ST



ADA CURB RAMP LAYOUT

FOR BIDDING PURPOSES ONLY

PROJECT	SHEET	TOTAL SHEETS
P TAPU(47)	44	112

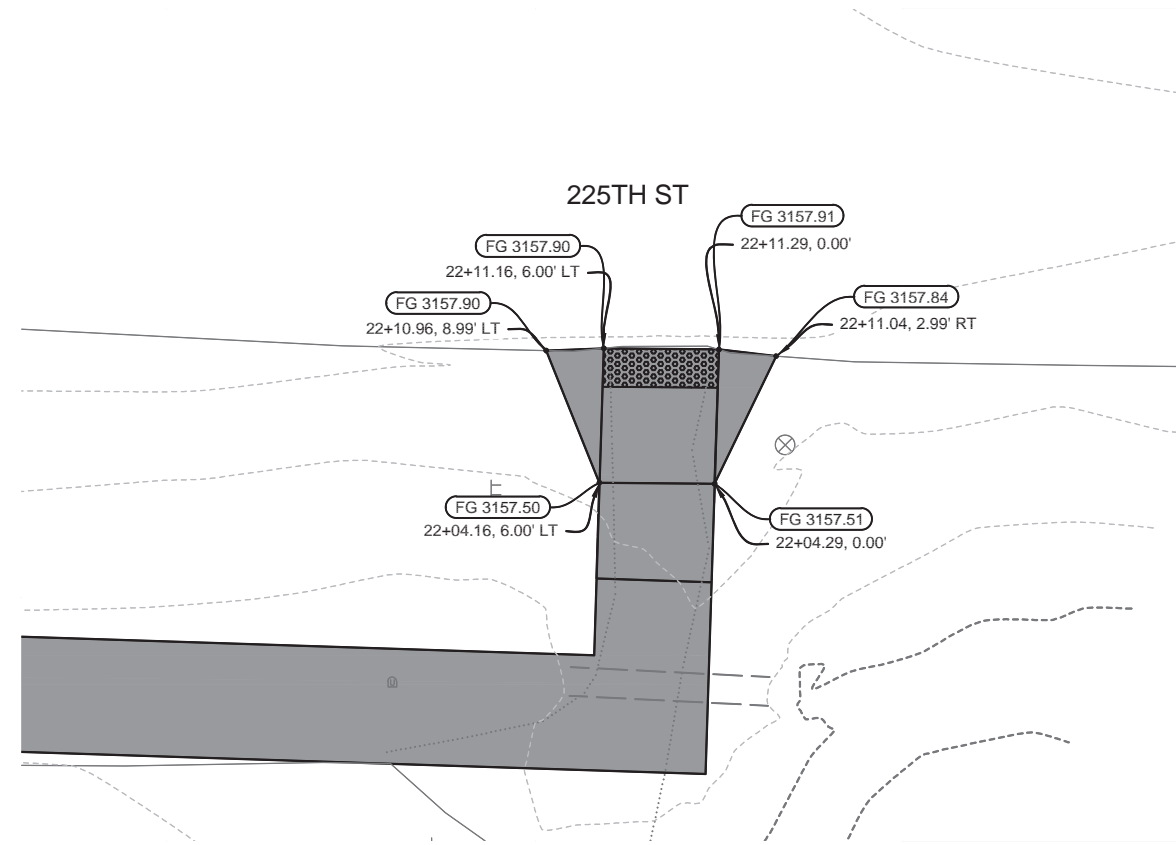

SOUTH QUADRANT 225TH ST & RADIAL LN

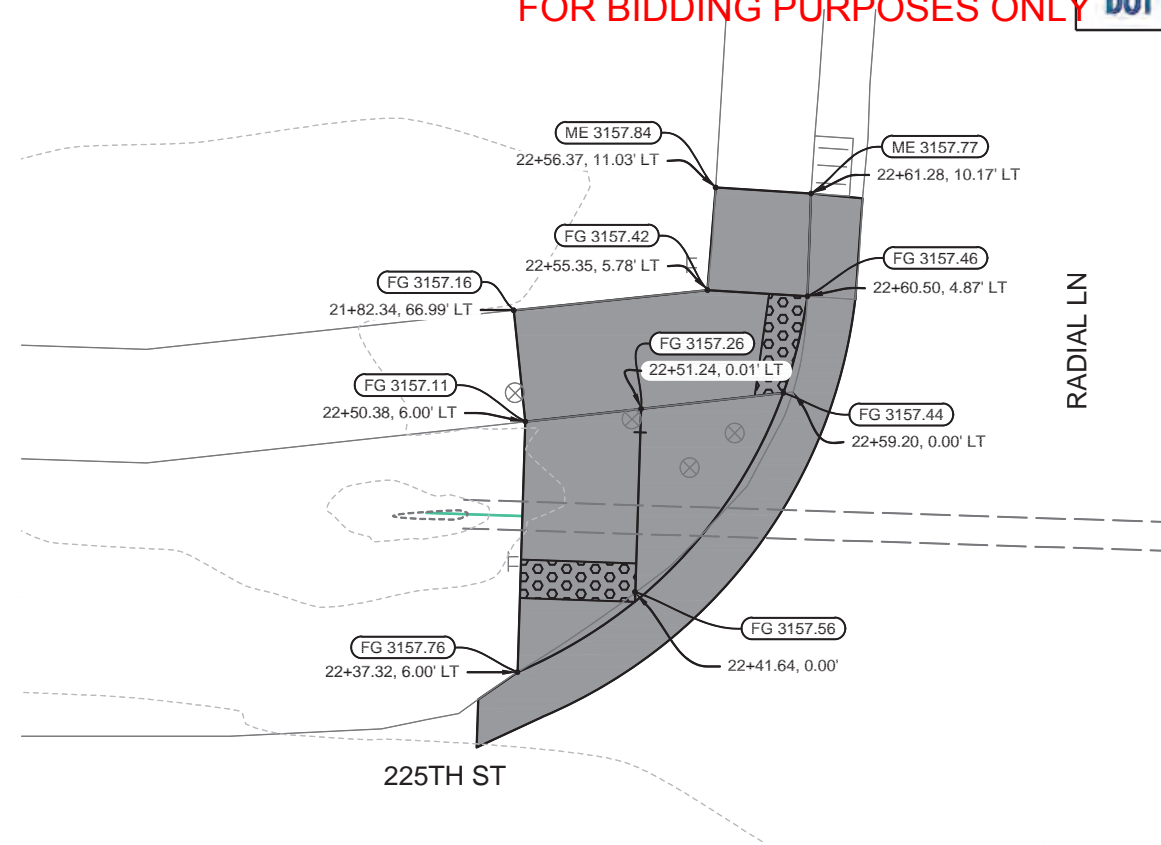

NW QUADRANT 225TH ST & RADIAL LN

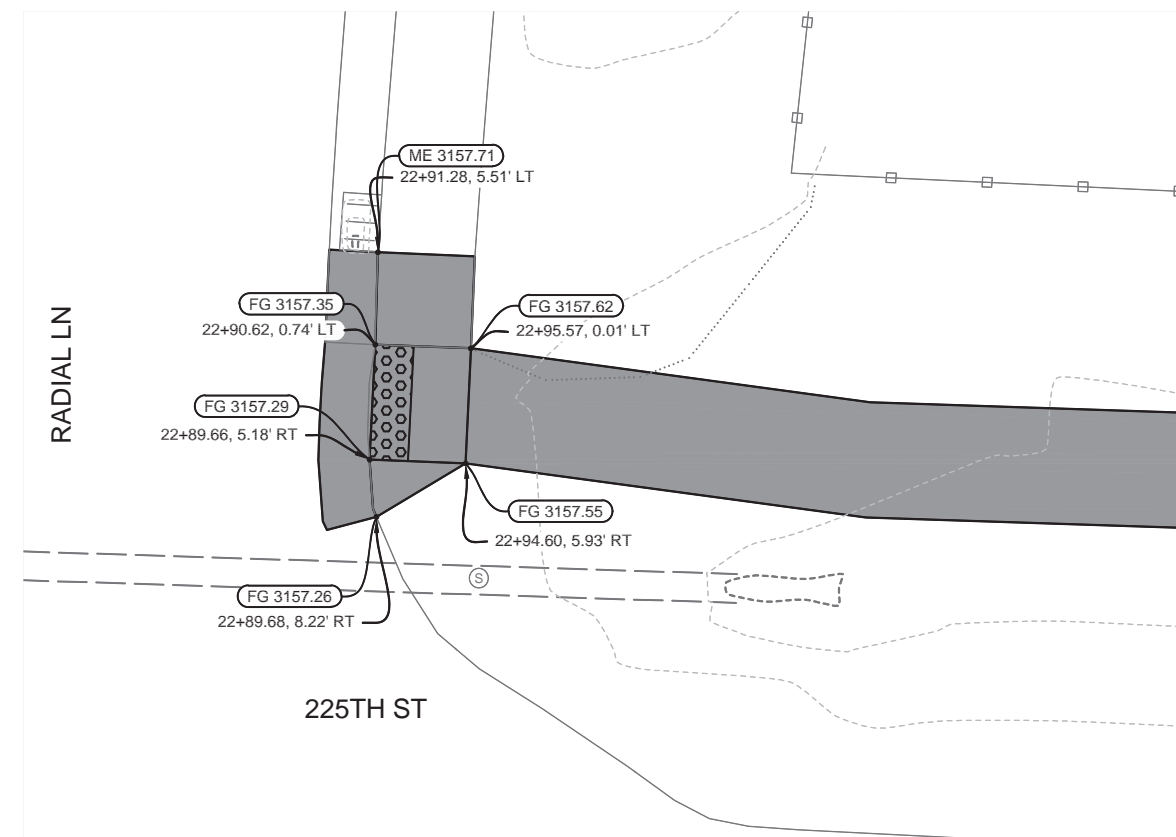
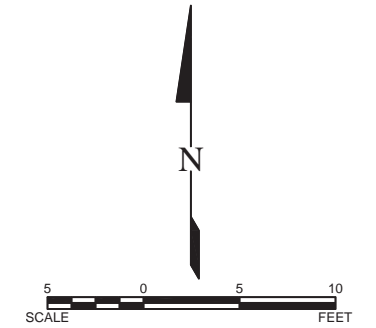

NE QUADRANT 225TH ST & RADIAL LN

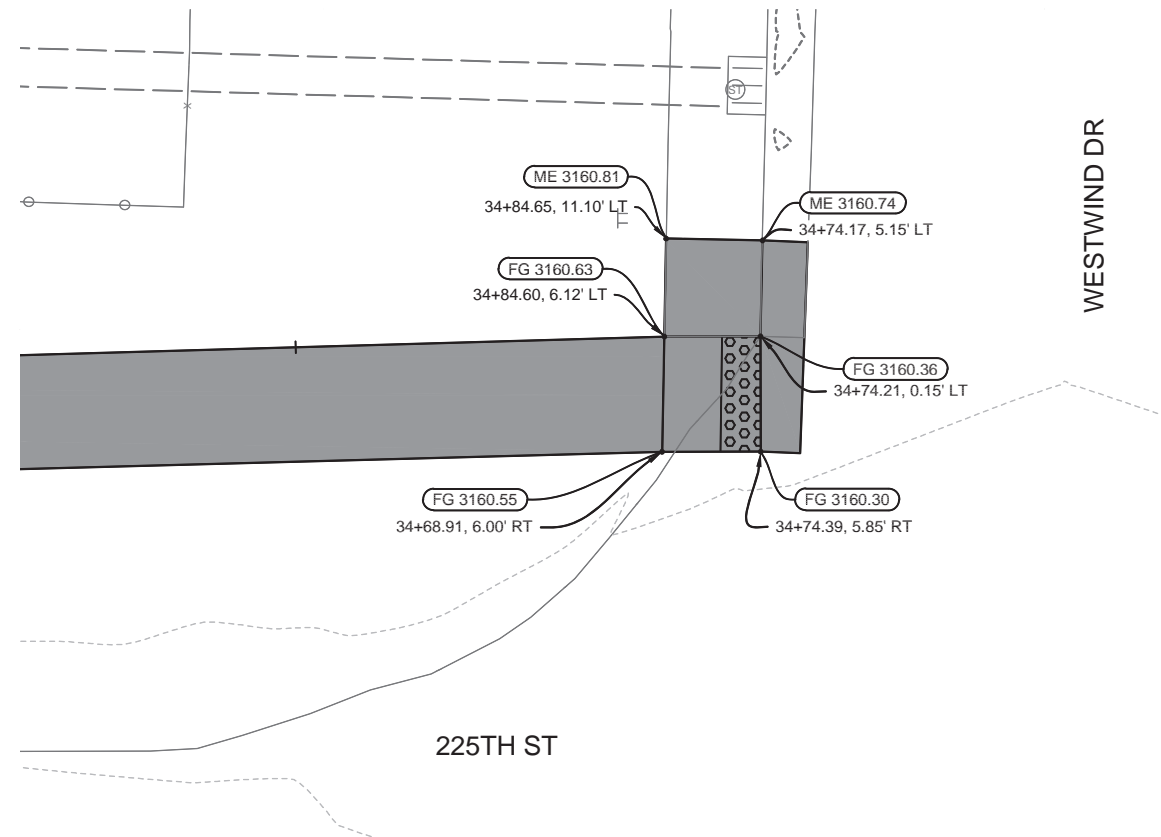

NW QUADRANT 225TH ST & WESTWIND DR



ADA CURB RAMP LAYOUT

FOR BIDDING PURPOSES ONLY

	PROJECT	SHEET	TOTAL SHEETS
	P TAPU(47)	45	112

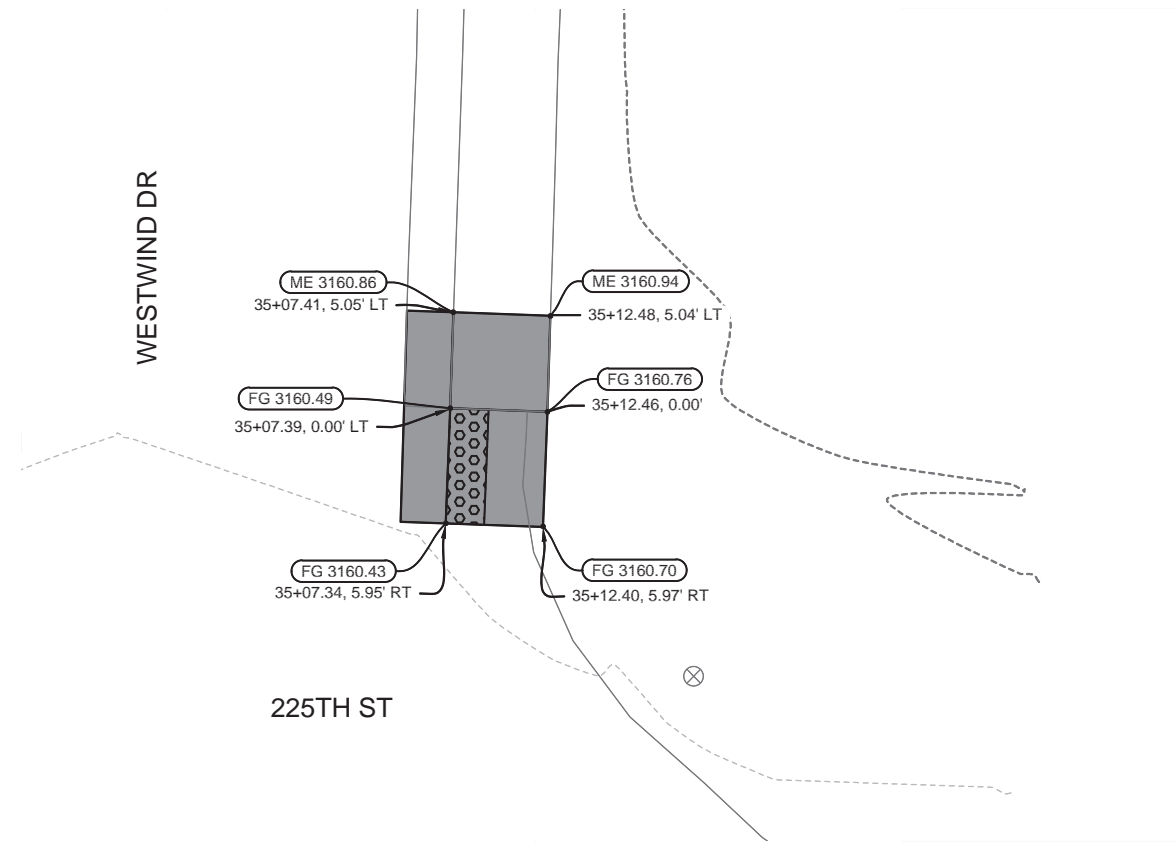
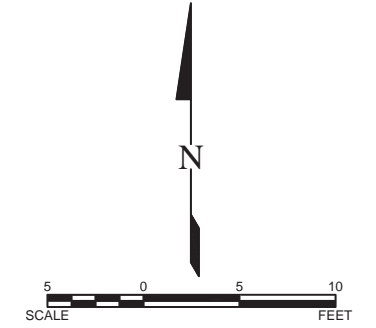

NE QUADRANT 225TH ST & WESTWIND DR

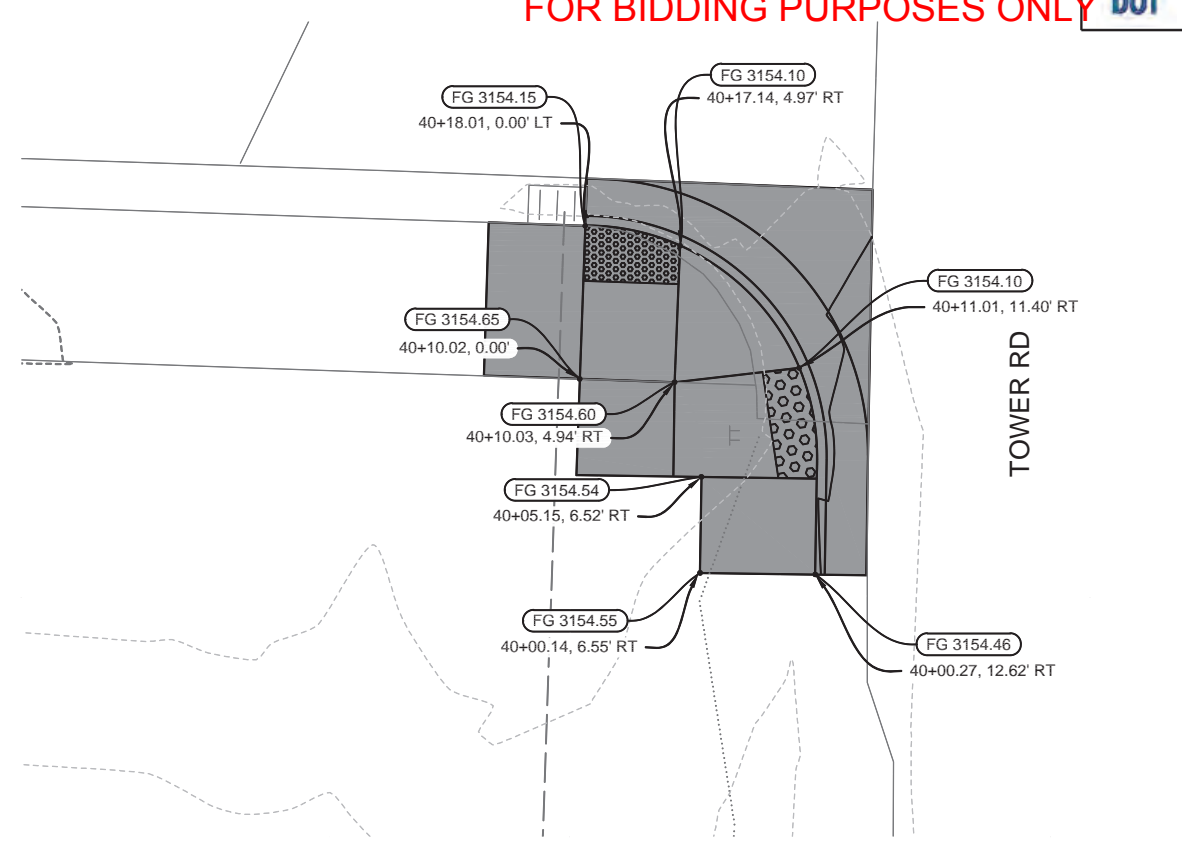

SW QUADRANT TOWER RD & DOUGLAS MS SOUTH PARKING LOT

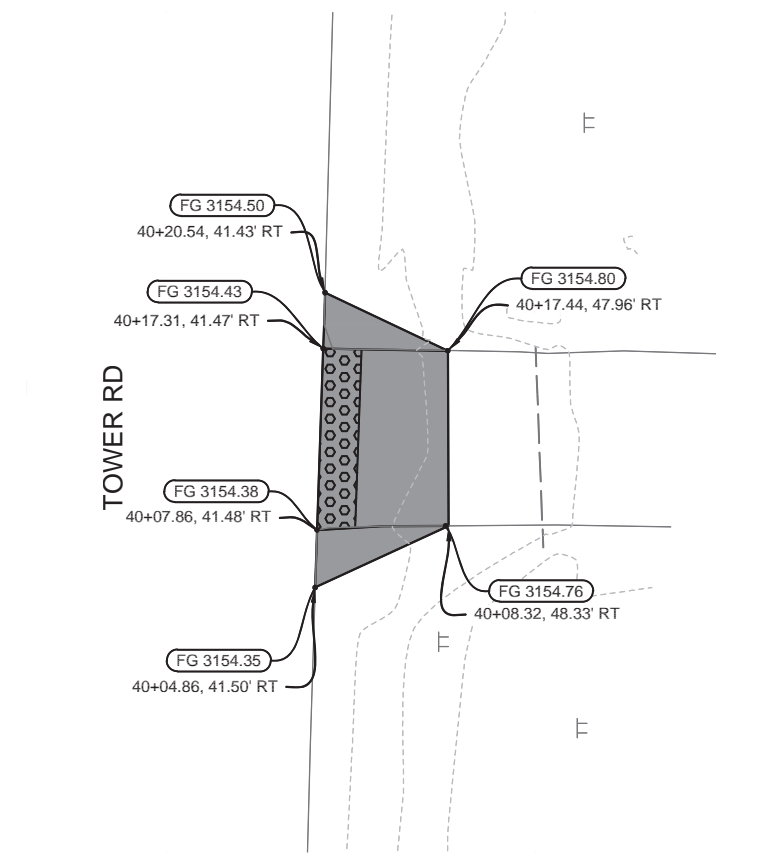

SE QUADRANT TOWER RD & DOUGLAS MS SOUTH PARKING LOT

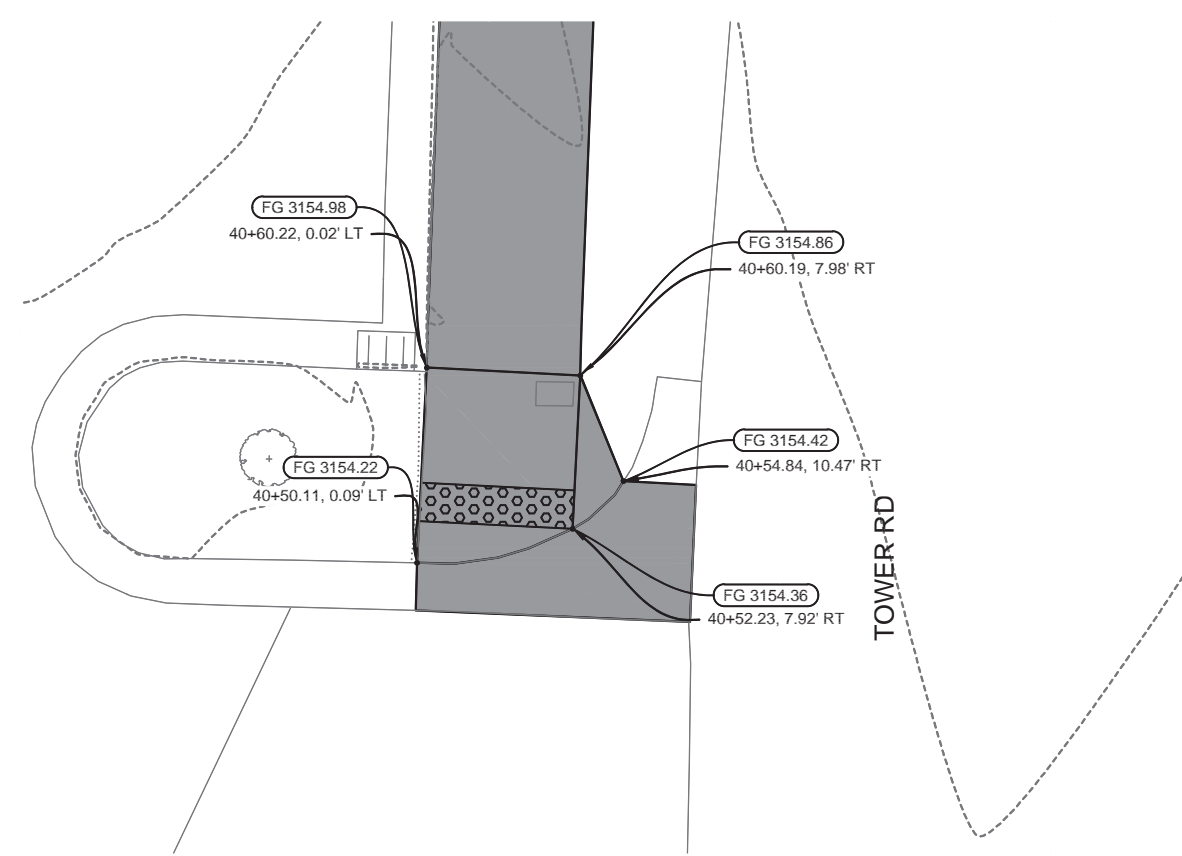

NW QUADRANT TOWER RD & DOUGLAS MS SOUTH PARKING LOT



ADA CURB RAMP LAYOUT

FOR BIDDING PURPOSES ONLY

	PROJECT	SHEET	TOTAL SHEETS
	P TAPU(47)	46	112

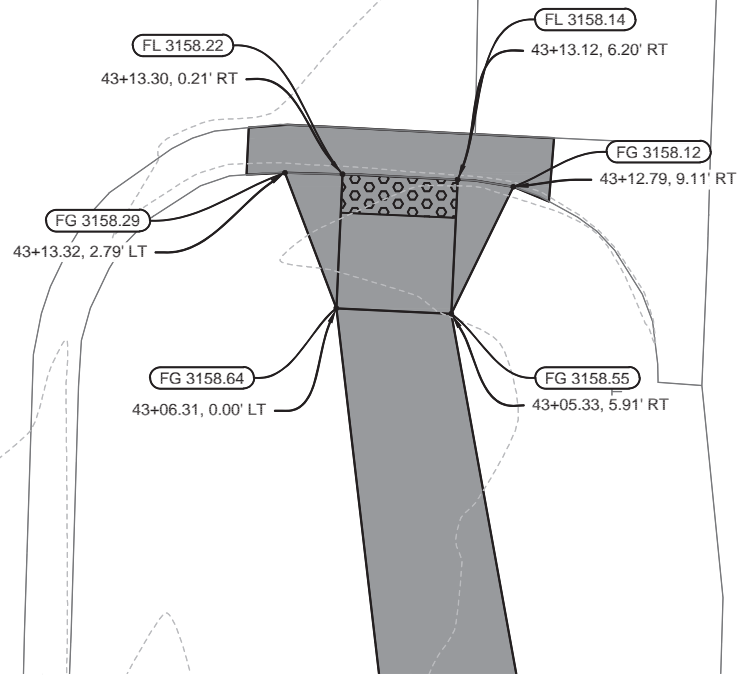
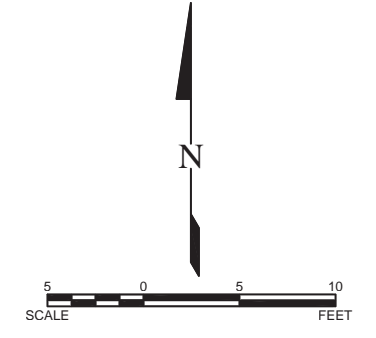

SW QUADRANT TOWER RD & DOUGLAS MS NORTH PARKING LOT

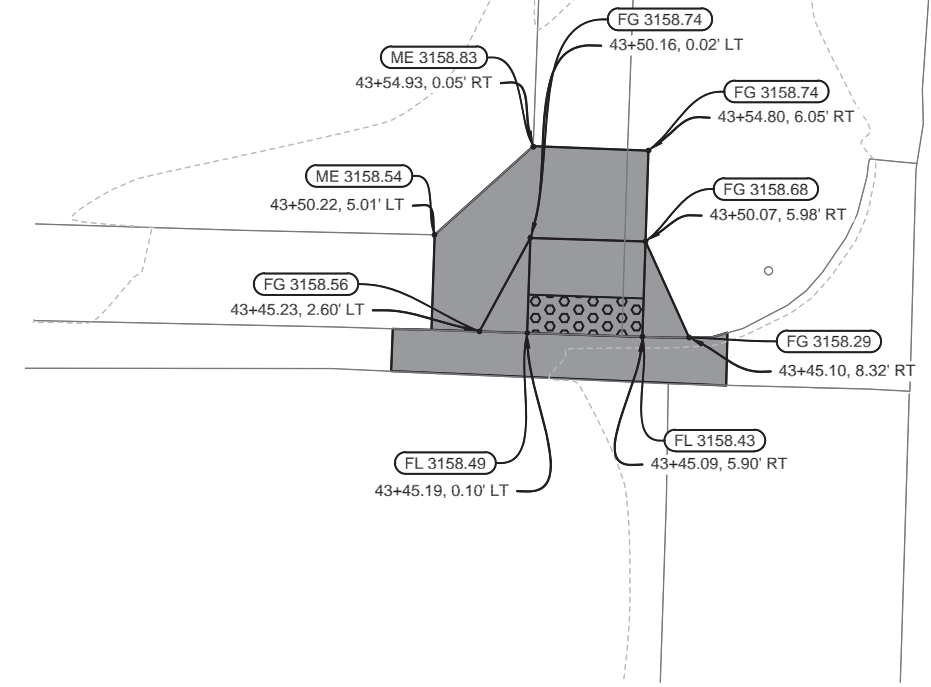

NW QUADRANT TOWER RD & DOUGLAS MS NORTH PARKING LOT



FOR BIDDING PURPOSES ONLY



PROJECT	SHEET	TOTAL SHEETS
P TAPU(47)	47	112

QUANTITIES THIS SHEET

DURABLE PAVEMENT MARKING 73 FT
24" WHITE

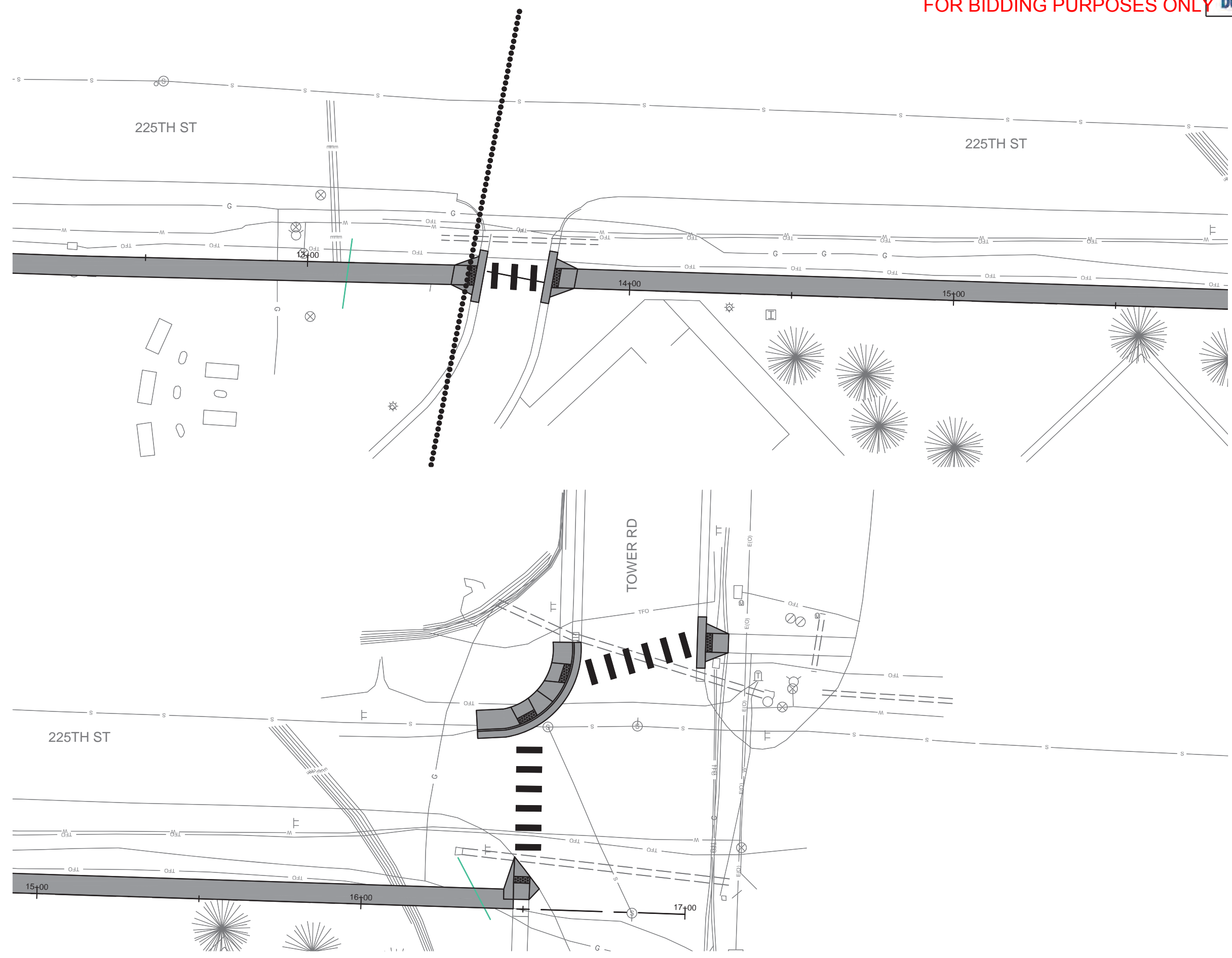

FOR BIDDING PURPOSES ONLY

QUANTITIES THIS SHEET

DURABLE PAVEMENT MARKING 24" WHITE	61 FT
2" X 2" PERFORATED TUBE POST	28 FT
RECTANGULAR RAPID FLASHING BEACON	2 EA
FLAT ALUMINUM SIGN, NONREMOVABLE COPY SUPER/ VERY HIGH INTENSITY	18 SF
DURABLE PAVEMENT MARKING, SYMBOL	2 EA

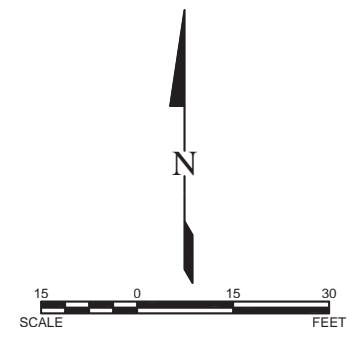
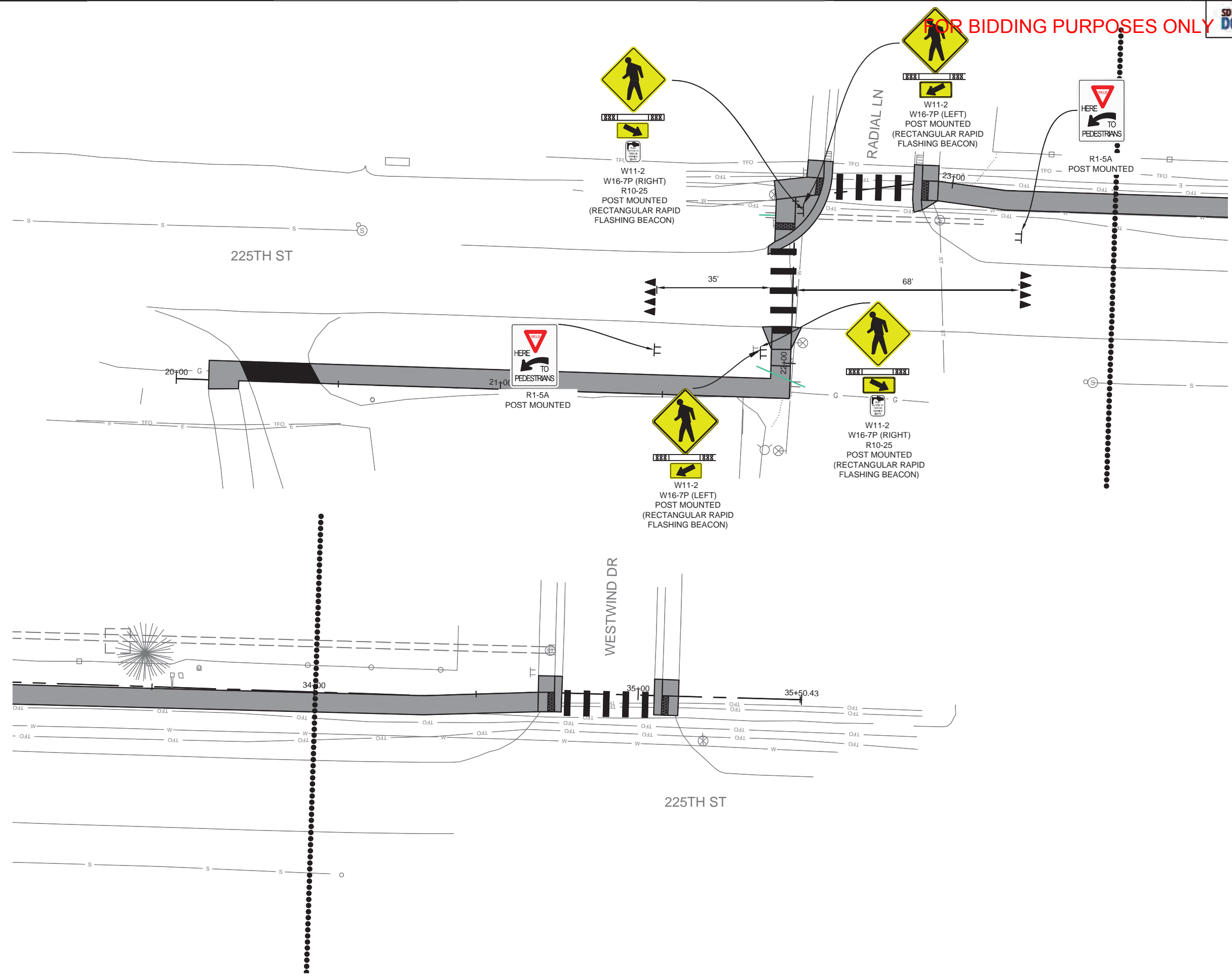

FOR BIDDING PURPOSES ONLY



PROJECT	SHEET	TOTAL SHEETS
P TAPU(47)	49	112

QUANTITIES THIS SHEET

DURABLE PAVEMENT MARKING 24" WHITE	53 FT
2" X 2" PERFORATED TUBE POST	28 FT
RECTANGULAR RAPID FLASHING BEACON	2 EA
FLAT ALUMINUM SIGN, NONREMOVABLE COPY SUPER/ VERY HIGH INTENSITY	18 SF
DURABLE PAVEMENT MARKING, SYMBOL	2 EA

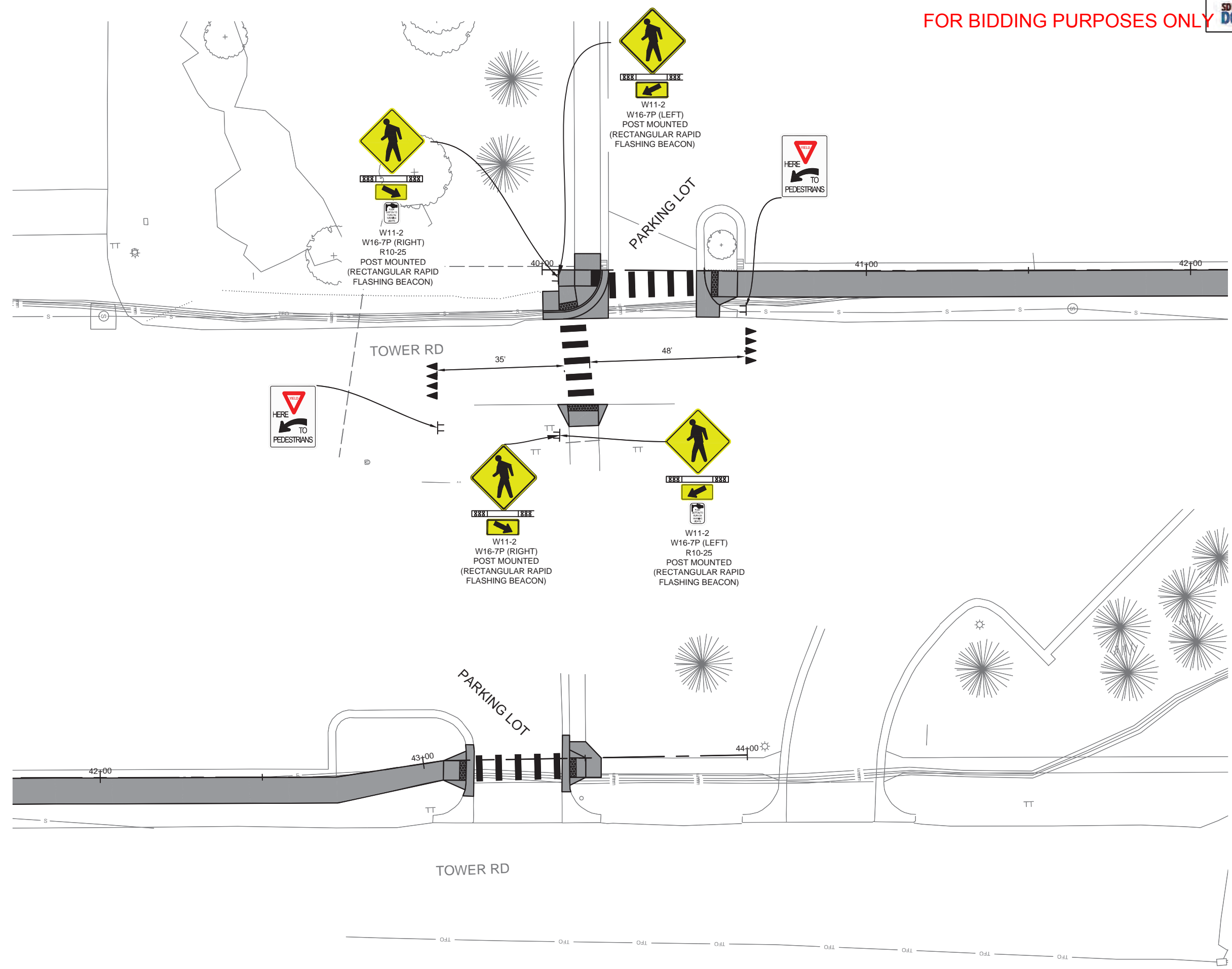

12" AREA DRAIN

FOR BIDDING PURPOSES ONLY

SD DOT	PROJECT	SHEET	TOTAL SHEETS
	P TAPU(47)	50	112

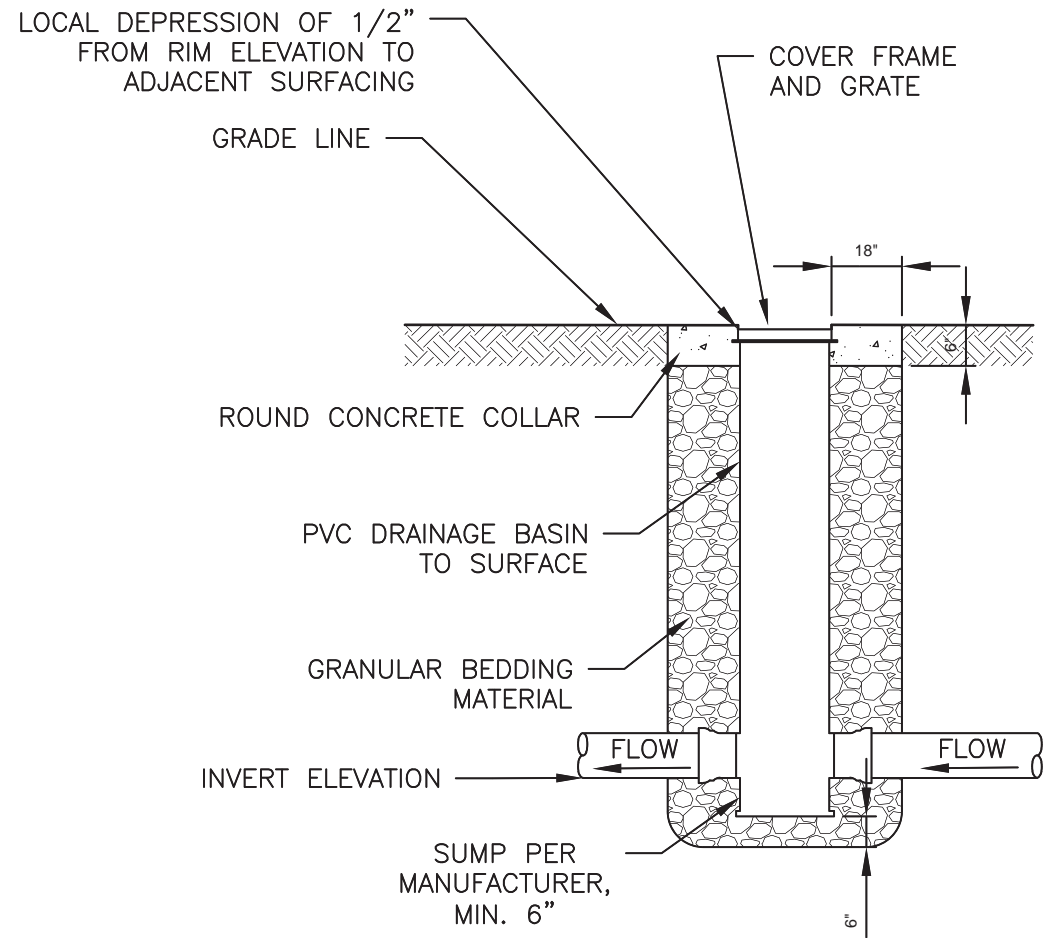

NOTES:

1. CONCRETE COLLAR SHALL HAVE (1) #4 REBAR HOOP MAINTAINING 3" CLEAR COVER.
2. CONCRETE COLLAR REQUIRED ONLY FOR TRAFFIC RATED STRUCTURES.
3. COVER DIAMETER SHOULD MATCH STRUCTURE DIAMETER.
4. ALL COVERS SHALL BE LOCKING STYLE.
5. GRATED COVER SHALL BE PEDESTRIAN STYLE OPENINGS.
6. CONTRACTOR MAY USE ALTERNATE INLETS WITH PRIOR APPROVAL BY ENGINEER.

1 PVC DRAINAGE MANHOLE
NO SCALE

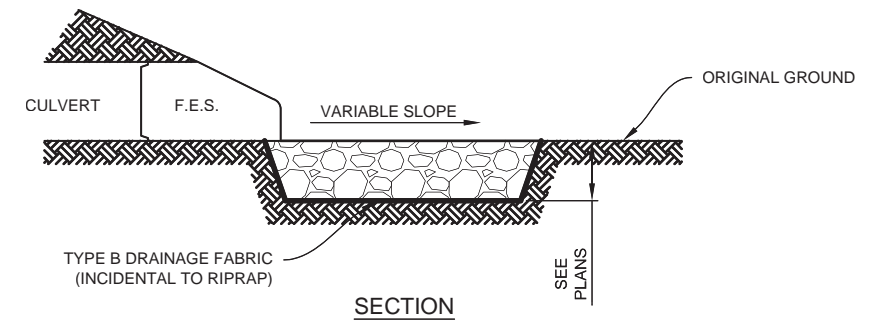
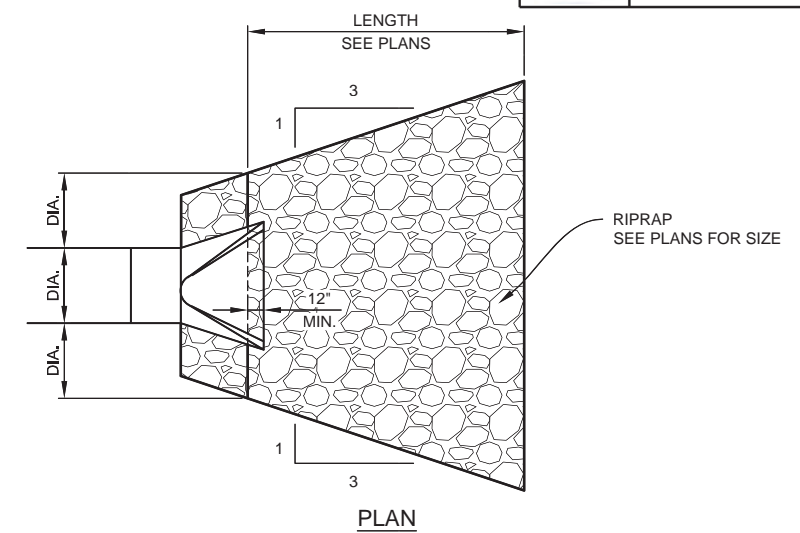

CULVERT WITH STANDARD END SECTION RIPRAP
NO SCALE



TOLERANCES IN DIMENSIONS
 Diameter: $\pm 1.5\%$ for 24" Dia. or less and $\pm 1\%$ or $\frac{3}{16}"$ whichever is more for 27" Dia. or greater.
 Diameters at joints: $\pm \frac{3}{16}"$ for 30" Dia. or less and $\pm \frac{1}{4}"$ for 36" or greater.
 Length of joint (J): $\pm \frac{1}{4}"$.
 Wall thickness (T): not less than design T by more than 5% or $\frac{3}{16}"$, whichever is greater.
 Laying length: shall not underrun by more than $\frac{1}{2}"$.

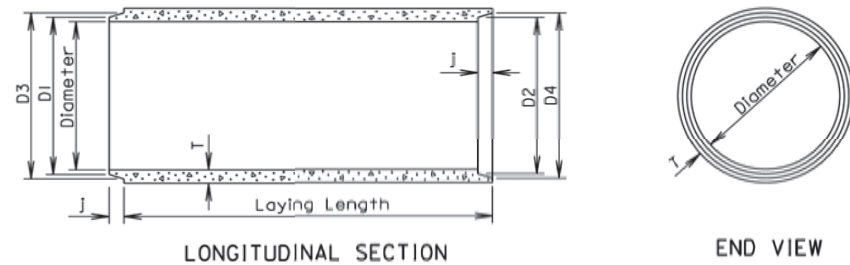

GENERAL NOTES:
 Construction of R. C. P. shall conform to the requirements of Section 990 of the Specifications.
 Not more than 2 four-foot sections shall be permitted near the ends of any culvert. Four-foot lengths shall be used only to secure the required length of culvert.

Diam. (in.)	Approx. Wt. /Ft. (lb.)	T (in.)	J (in.)	D1 (in.)	D2 (in.)	D3 (in.)	D4 (in.)
12	92	2	1 3/4	13 3/4	13 5/8	13 3/8	14 1/4
15	127	2 1/4	2	16 1/2	16 5/8	17 1/4	17 5/8
18	168	2 1/2	2 1/4	19 5/8	20	20 3/8	20 3/4
21	214	2 3/4	2 1/2	22 5/8	23 1/4	23 3/4	24 1/8
24	265	3	2 3/4	26	26 3/8	27	27 3/8
27	322	3 1/4	3	29 1/4	29 5/8	30 1/4	30 5/8
30	384	3 1/2	3 1/4	32 3/8	32 3/4	33 1/2	33 5/8
36	524	4	3 3/4	38 3/4	39 1/4	40	40 1/2
42	685	4 1/2	4	45 1/8	45 5/8	46 1/2	47
48	867	5	4 1/2	51 1/2	52	53	53 1/2
54	1070	5 1/2	4 1/2	57 1/8	58 3/8	59 3/8	59 5/8
60	1296	6	5	64 1/4	64 3/4	66	66 1/2
66	1542	6 1/2	5 1/2	70 5/8	71 1/8	72 1/2	73
72	1810	7	6	77	77 1/2	79	79 1/2
78	2098	7 1/2	6 1/2	83 3/8	83 3/8	85 5/8	86 1/8
84	2410	8	7	89 3/4	90 1/4	92 1/8	92 5/8
90	2740	8 1/2	7	95 3/4	96 1/4	98 1/8	98 5/8
96	2950	9	7	102 1/8	102 5/8	104 1/2	105
102	3075	9 1/2	7 1/2	109	109 1/2	111 1/2	112
108	3870	10	7 1/2	115 1/2	116	118	118 1/2

June 26, 2015

Published Date: 2026	S D D O T	REINFORCED CONCRETE PIPE	PLATE NUMBER 450.01
			Sheet 1 of 1

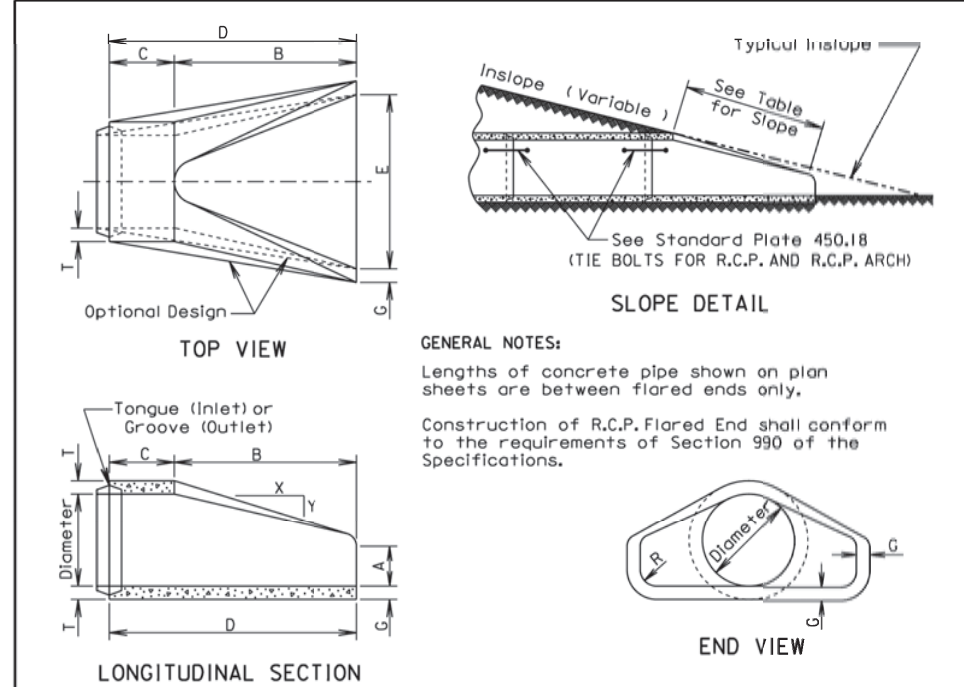

GENERAL NOTES:
 Lengths of concrete pipe shown on plan sheets are between flared ends only.
 Construction of R.C.P. Flared End shall conform to the requirements of Section 990 of the Specifications.

Dia. (in.)	Approx. Wt. of Section (lbs.)	Approx. Slope (X to Y)	T (in.)	A (in.)	B (in.)	C (in.)	D (in.)	E (in.)	G (in.)	R (in.)
12	530	2.4:1	2	4	24	48 3/8	72 3/8	24	2	1 1/2
15	740	2.4:1	2 1/4	6	27	46	73	30	2 1/4	1 1/2
18	990	2.3:1	2 1/2	9	27	46	73	36	2 1/2	1 1/2
21	1280	2.4:1	2 3/4	9	36	37 1/2	73 1/2	42	2 3/4	1 1/2
24	1520	2.5:1	3	9 1/2	43 1/2	30	73 1/2	48	3	1 1/2
27	1930	2.5:1	3 1/4	10 1/2	49 1/2	24	73 1/2	54	3 1/4	1 1/2
30	2190	2.5:1	3 1/2	12	54	19 3/4	73 3/4	60	3 1/2	1 1/2
36	4100	2.5:1	4	15	63	34 3/4	97 3/4	72	4	1 1/2
42	5380	2.5:1	4 1/2	21	63	35	98	78	4 1/2	1 1/2
48	6550	2.5:1	5	24	72	26	98	84	5	1 1/2
54	8240	2:1	5 1/2	27	65	33 1/4	98 1/4	90	5 1/2	1 1/2
60	8730	1.9:1	6	35	60	39	99	96	5	1 1/2
66	10710	1.7:1	6 1/2	30	72	27	99	102	5 1/2	1 1/2
72	12520	1.8:1	7	36	78	21	99	108	6	1 1/2
78	14770	1.8:1	7 1/2	36	90	21	111	114	6 1/2	1 1/2
84	18160	1.6:1	8	36	90 1/2	21	111 1/2	120	6 1/2	1 1/2
90	20900	1.5:1	8 1/2	41	87 1/2	24	111 1/2	132	6 1/2	6

June 26, 2015

Published Date: 2026	S D D O T	R. C. P. FLARED ENDS	PLATE NUMBER 450.10
			Sheet 1 of 1



Posted Speed Prior to Work (M.P.H.)	Spacing of Advance Warning Signs (Feet) (A)	Spacing of Channelizing Devices (Feet) (G)
0 - 30	200	25
35 - 40	350	25
45	500	25
50	500	50
55	750	50
60 - 65	1000	50

Flagger
 Channelizing Device

For low-volume traffic situations with short work zones on straight roadways where the flagger is visible to road users approaching from both directions, a single flagger may be used.

The ROAD WORK AHEAD and the END ROAD WORK signs may be omitted for short duration operations (1 hour or less).

For tack and/or flush seal operations, when flaggers are not being used, the FRESH OIL sign (W21-2) will be displayed in advance of the liquid asphalt areas.

Flashing warning lights and/or flags may be used to call attention to the advance warning signs.

The channelizing devices will be drums or 42" cones.

Channelizing devices are not required along the centerline adjacent to work area when pilot cars are utilized for escorting traffic through the work area.

Channelizing devices and flaggers will be used at intersecting roads to control intersecting road traffic as required.

The buffer space should be extended so that the two-way traffic taper is placed before a horizontal or vertical curve to provide adequate sight distance for the flagger and queue of stopped vehicles.

The length of A may be adjusted to fit field conditions.

Warning sign sequence in opposite direction same as below.

January 22, 2021

S D D O T	LANE CLOSURE WITH FLAGGER PROVIDED	PLATE NUMBER 634.23
	Published Date: 2026	Sheet 1 of 1

The stated radii on the plans and cross sections refer to this line and it will also be the basis for horizontal linear foot measurement and payment.

1/4" to 1/2" Radius (Typ.)

Type	T ₁ (Inches)	T ₂ (Inches)	Cu. Yd. Per Lin. Ft.	Lin. Ft. Per Cu. Yd.
B66	6	5 1/16	0.057	17.7
B67	7	6 1/16	0.065	15.4
B68	8	7 1/16	0.073	13.7
B68.5	8.5	7 9/16	0.077	13.0
B69	9	8 1/16	0.081	12.3
B69.5	9.5	8 9/16	0.085	11.7
B610	10	9 1/16	0.090	11.2
B610.5	10.5	9 9/16	0.094	10.7
B611	11	10 1/16	0.098	10.2
B611.5	11.5	10 9/16	0.102	9.8
B612	12	11 1/16	0.106	9.4

GENERAL NOTES:

When concrete curb and gutter longitudinally adjoins new concrete pavement, the method of attachment will be by one of the methods shown on standard plate 380.21.

See standard plate 650.90 for expansion and contraction joints in the curb and gutter.

January 22, 2023

S D D O T	TYPE B CONCRETE CURB AND GUTTER	PLATE NUMBER 650.01
	Published Date: 2026	Sheet 1 of 1



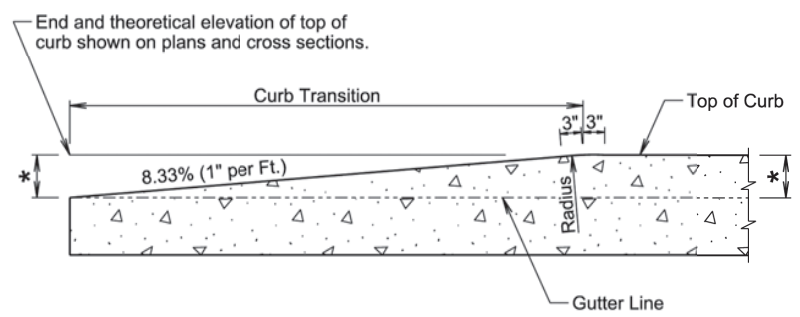

LONGITUDINAL SECTION
(Concrete Curb Taper)

December 23, 2019

Published Date: 2026	S D D O T	CONCRETE CURB TAPER	PLATE NUMBER
			650.35
			Sheet 1 of 1

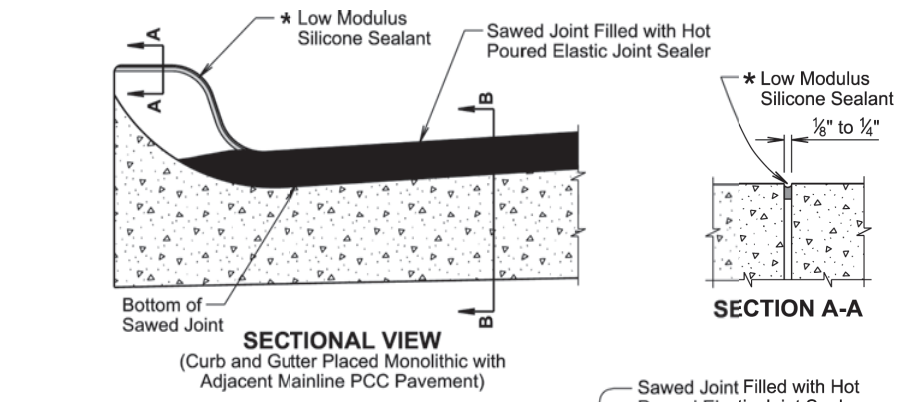

SECTIONAL VIEW
(Curb and Gutter Placed Monolithic with Adjacent Mainline PCC Pavement)

SECTION A-A

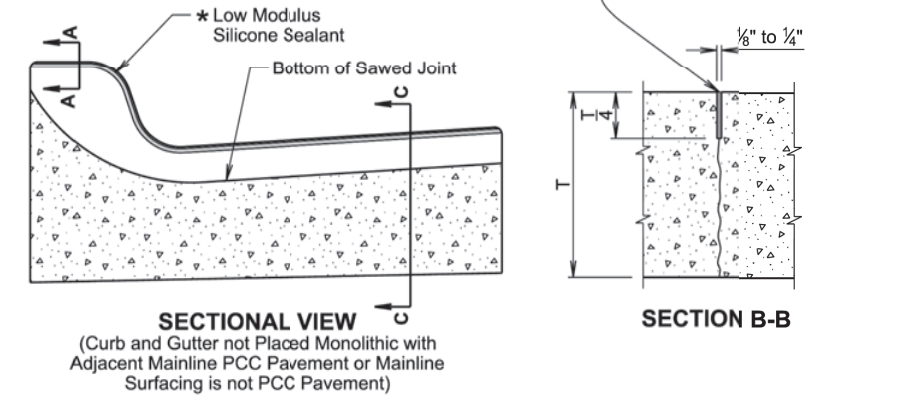

SECTIONAL VIEW
(Curb and Gutter not Placed Monolithic with Adjacent Mainline PCC Pavement or Mainline Surfacing is not PCC Pavement)

SECTION B-B

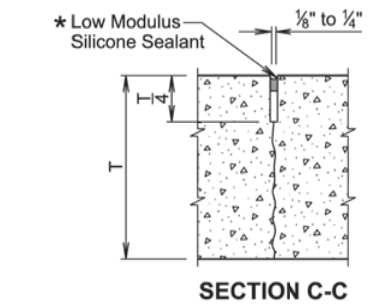

SECTION C-C

* The silicone sealant will be placed such that it completely seals the joint and is bonded to the sides of the clean joint as approved by the Engineer.

December 23, 2019

Published Date: 2026	S D D O T	JOINTS IN CONCRETE CURB AND GUTTER	PLATE NUMBER
			650.90
			Sheet 1 of 2



Curb ramp slopes are designed at 7.5% unless stated otherwise in the plans. The curb ramp may have a maximum slope of 8.3% and will not exceed 15' in length unless stated otherwise in the plans.

The curb ramp length may be computed based on the intersection of a continuous 1.5% theoretical slope from theoretical top of curb (TTOC) with the curb ramp using a continuous 7.5% curb ramp slope. The elevation of point TCR will always be higher than the elevation of point TTOC unless specified otherwise in the plans. The curb ramp length dimension as shown in the plans will be adjusted as necessary to meet all slope and length requirements based on field geometrics.

The cross slope of the ramp will not be steeper than 2.1%. Plans are designed using a 1.5% slope unless stated otherwise in the plans.

** The slope in the landing will not be steeper than 2.1% in any direction of pedestrian travel. Plans are designed using a 1.5% slope unless stated otherwise in the plans.

*** The curb transition will be a minimum of 6' long, a maximum of 10' long, and the curb transition slope will not be steeper than 10% unless stated otherwise in the plans. The curb transition length will be adjusted as necessary to meet slope and length requirements based on field geometrics.

**** The ramp width is 5' unless stated otherwise in the plans.

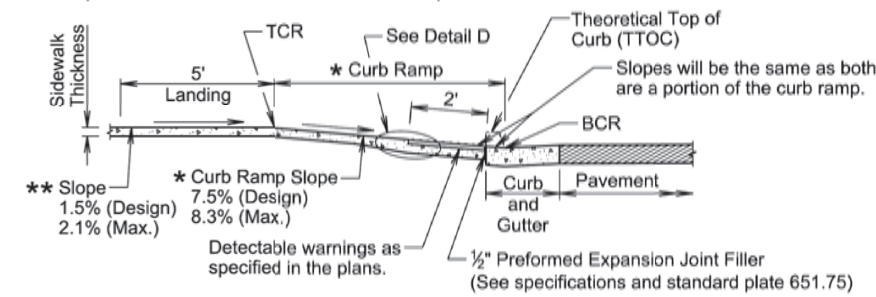

SECTION A-A

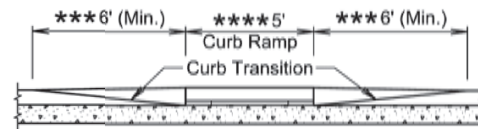

SECTIONAL VIEW B-B

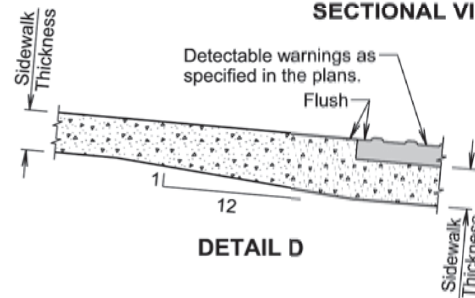

DETAIL D

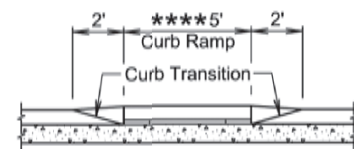

SECTIONAL VIEW C-C

April 8, 2025

Published Date: 2026	S D D O T	TYPE 1 CURB RAMP (PERPENDICULAR CURB RAMP)	PLATE NUMBER
			651.01
			Sheet 2 of 3

GENERAL NOTES:

For illustrative purpose only, type 1 detectable warnings are shown in the drawings.

For illustrative purpose only, PCC fillet sections are shown in the drawings. The curb ramp depicted on this standard plate may be used with a PCC fillet section or curb and gutter.

The curb ramp will be placed at the location stated in the plans.

Sidewalk will not be placed adjacent to the curb ramp flares when a 2-foot curb transition is used unless shown otherwise in the plans.

* Care will be taken to ensure a uniform grade on the curb ramp, free of sags and short grade changes.

Surface texture of the curb ramp will be obtained by coarse brooming transverse to the slope of the curb ramp.

The normal gutter line profile will be maintained through the area of the ramp opening.

Joints will be sawed or tooled into the concrete adjacent to the detectable warnings to alleviate possible corner cracking.

Care will be taken to ensure that the surface of the detectable warnings are clean and maintains a uniform color.

The detectable warnings will be cut as necessary to fit the plan specified limits of the detectable warnings. Cost for cutting the detectable warnings will be incidental to the corresponding detectable warning contract item.

There will be no separate payment for curb ramps. The curb ramp will be measured and paid for at the contract unit price per square foot for the corresponding concrete sidewalk contract item. The square foot area of the detectable warnings will be included in the measured and paid for quantity of sidewalk.

If rebar is placed in the landing as depicted in detail E, the cost of the materials, labor, and equipment to furnish and install the rebar will be incidental to the contract unit price per square foot for the corresponding concrete sidewalk contract item.

The curb transitions and ramp opening will be measured and paid for at the contract unit price per foot for the corresponding curb and gutter contract item when curb and gutter is used. The curb transitions and ramp opening will be measured and paid for at the contract unit price per square yard for the corresponding PCC fillet section contract item when a PCC fillet section is used.

Type 1 detectable warnings will be measured to the nearest square foot. All costs for furnishing and installing type 1 detectable warnings including labor, equipment, materials, and incidentals will be paid for at the contract unit price per square foot for "Type 1 Detectable Warnings".

Type 2 detectable warnings will be measured to the nearest square foot. All costs for furnishing and installing type 2 detectable warnings including labor, equipment, and materials, including adhesive, necessary sealant or grout, and necessary grinding will be paid for at the contract unit price per square foot for "Type 2 Detectable Warnings".

April 8, 2025

Published Date: 2026	S D D O T	TYPE 1 CURB RAMP (PERPENDICULAR CURB RAMP)	PLATE NUMBER
			651.01
			Sheet 3 of 3



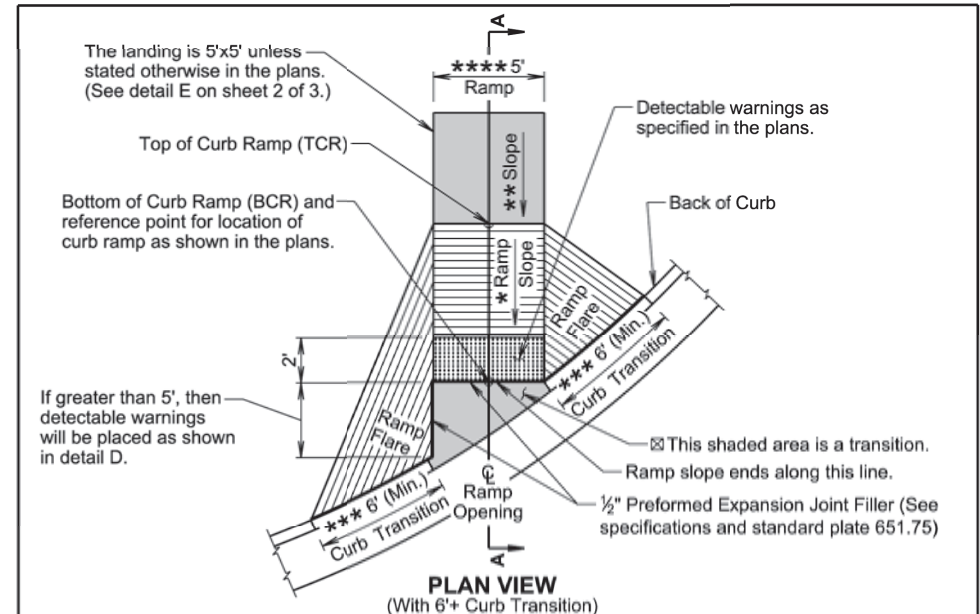

☒ The slope within the transition area will not be steeper than 5%. The concrete within the transition will be placed monolithic with the curb and gutter or fillet section concrete. The concrete thickness within the transition will be the same as the curb and gutter or fillet section concrete thickness.

*** The curb transition will be a minimum of 6' long, a maximum of 10' long, and the curb transition slope will not be steeper than 10% unless stated otherwise in the plans. The curb transition length will be adjusted as necessary to meet slope and length requirements based on field geometrics.

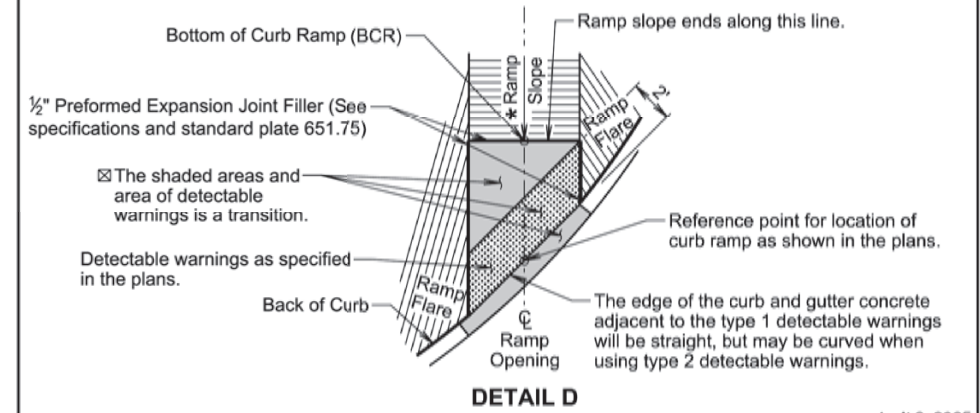

Published Date: 2026	SD DOT	TYPE 2 CURB RAMP (DIRECTIONAL CURB RAMP)	PLATE NUMBER 651.02
		Sheet 1 of 3	
		April 8, 2025	

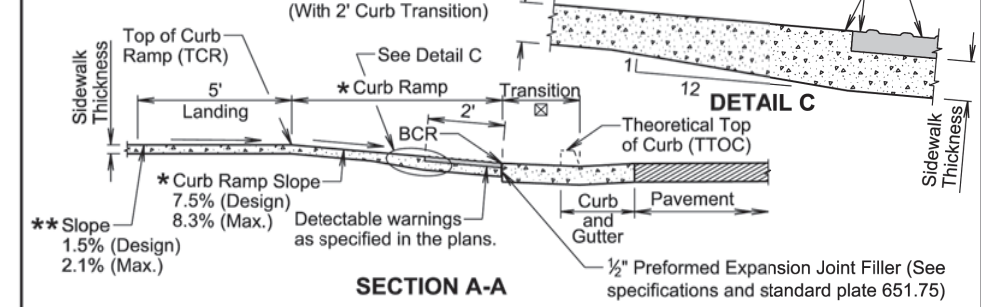
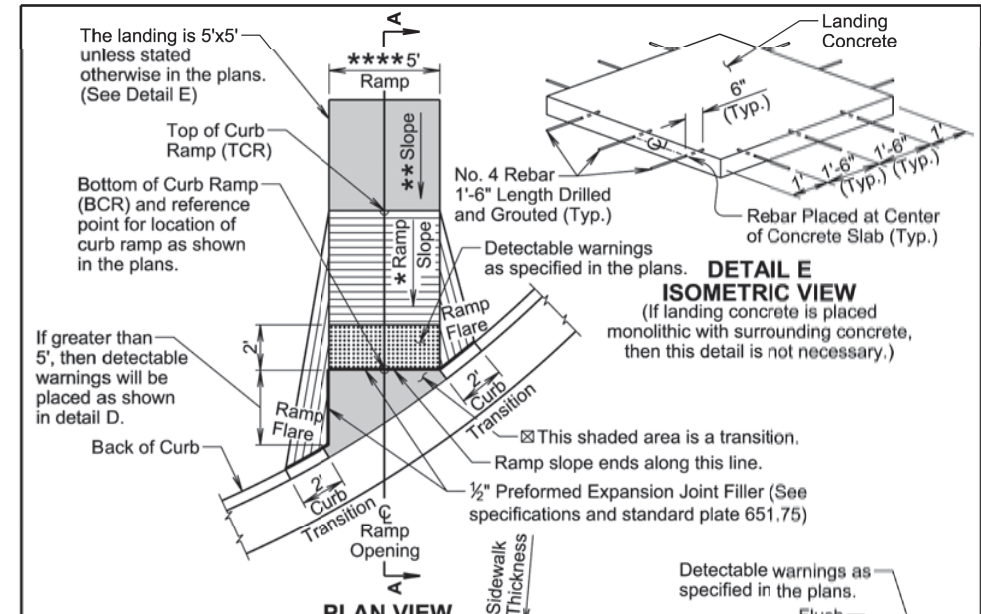

Curb ramp slopes are designed at 7.5% unless stated otherwise in the plans. The curb ramp may have a maximum slope of 8.3% and will not exceed 15' in length unless stated otherwise in the plans.

* The elevation of point TCR will always be higher than the elevation of point TTOC unless specified otherwise in the plans. The curb ramp length dimension as shown in the plans will be adjusted as necessary to meet all slope and length requirements based on field geometrics.

The cross slope of the ramp will not be steeper than 2.1%. Plans are designed using a 1.5% slope unless stated otherwise in the plans.

** The slope in the landing will not be steeper than 2.1% in any direction of pedestrian travel. Plans are designed using a 1.5% slope unless stated otherwise in the plans.

**** The ramp width is 5' unless stated otherwise in the plans.

Published Date: 2026	SD DOT	TYPE 2 CURB RAMP (DIRECTIONAL CURB RAMP)	PLATE NUMBER 651.02
		Sheet 2 of 3	
		April 8, 2025	

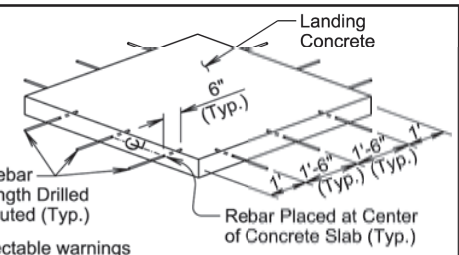

DETAIL E ISOMETRIC VIEW (If landing concrete is placed monolithic with surrounding concrete, then this detail is not necessary.)



GENERAL NOTES:

For illustrative purpose only, type 1 detectable warnings are shown in the drawings.

The curb ramp depicted on this standard plate may be used with a PCC fillet section or curb and gutter. The curb ramp will be placed at the location stated in the plans.

Sidewalk will not be placed adjacent to the curb ramp flares when a 2-foot curb transition is used unless shown otherwise in the plans.

* Care will be taken to ensure a uniform grade on the curb ramp, free of sags and short grade changes.

Surface texture of the curb ramp will be obtained by coarse brooming transverse to the slope of the curb ramp.

The normal gutter line profile will be maintained through the area of the ramp opening.

Joints will be sawed or tooled into the concrete adjacent to the detectable warnings to alleviate possible corner cracking.

Care will be taken to ensure that the surface of the detectable warnings are clean and maintains a uniform color.

The detectable warnings will be cut as necessary to fit the plan specified limits of the detectable warnings. Cost for cutting the detectable warnings will be incidental to the corresponding detectable warning contract item.

There will be no separate payment for curb ramps. The curb ramp will be measured and paid for at the contract unit price per square foot for the corresponding concrete sidewalk contract item. The square foot area of the detectable warnings will be included in the measured and paid for quantity of sidewalk.

If rebar is placed in the landing as depicted in DETAIL E, the cost of the materials, labor, and equipment to furnish and install the rebar will be incidental to the contract unit price per square foot for the corresponding concrete sidewalk contract item.

The curb transitions and ramp opening will be measured and paid for at the contract unit price per foot for the corresponding curb and gutter contract item when curb and gutter is used. The curb transitions and ramp opening will be measured and paid for at the contract unit price per square yard for the corresponding PCC fillet section contract item when a PCC fillet section is used.

All costs for furnishing and installing the transition area at the base of the curb ramp will be incidental to the contract unit price per foot for the corresponding curb and gutter contract item when curb and gutter is used and will be incidental to the contract unit price per square yard for the corresponding PCC fillet section contract item when a PCC fillet section is used.

Type 1 detectable warnings will be measured to the nearest square foot. All costs for furnishing and installing type 1 detectable warnings including labor, equipment, materials, and incidentals will be paid for at the contract unit price per square foot for "Type 1 Detectable Warnings".

Type 2 detectable warnings will be measured to the nearest square foot. All costs for furnishing and installing type 2 detectable warnings including labor, equipment, and materials, including adhesive, necessary sealant or grout, and necessary grinding will be paid for at the contract unit price per square foot for "Type 2 Detectable Warnings".

April 8, 2025

Published Date: 2026	S D D O T	TYPE 2 CURB RAMP (DIRECTIONAL CURB RAMP)	PLATE NUMBER 651.02
			Sheet 3 of 3

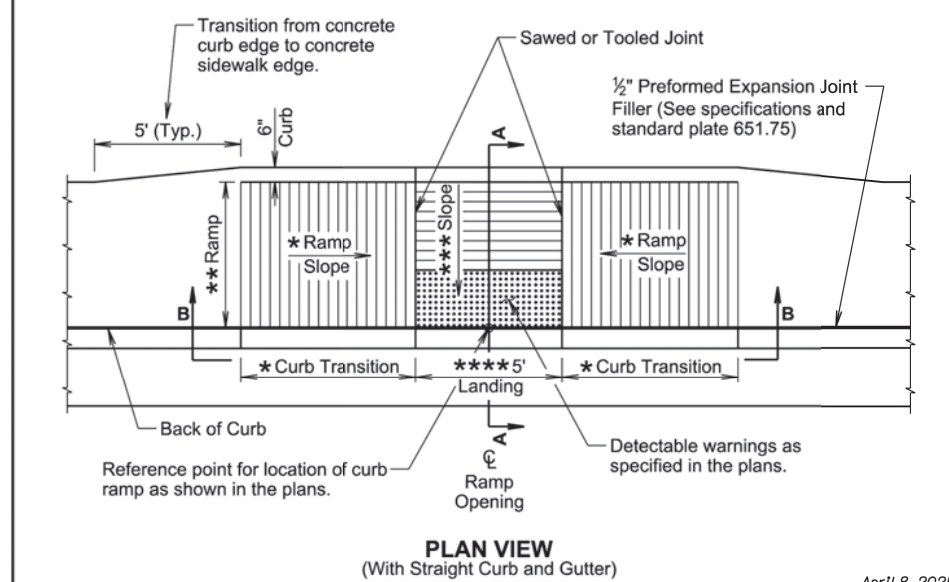
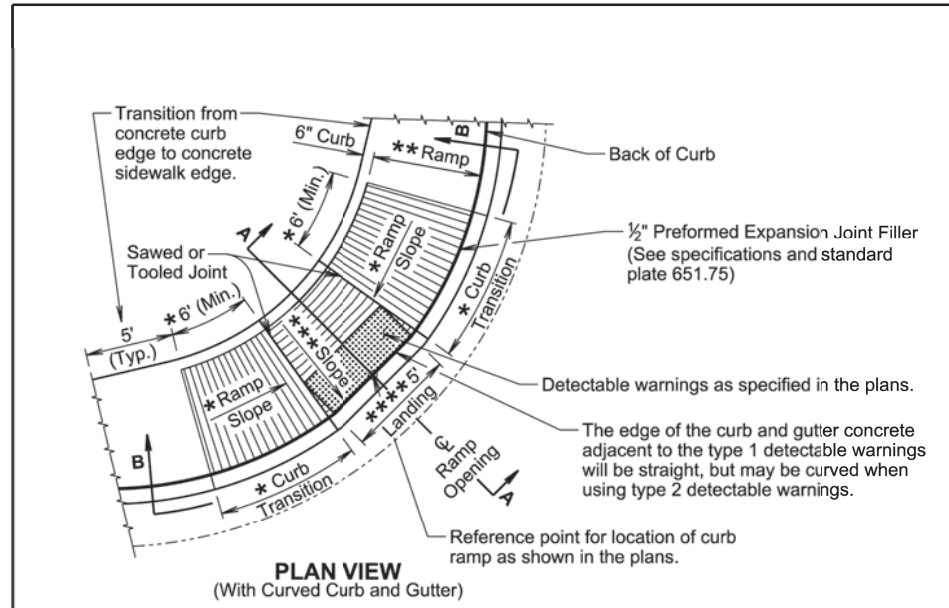

April 8, 2025

Published Date: 2026	S D D O T	TYPE 3 CURB RAMP (PARALLEL CURB RAMP)	PLATE NUMBER 651.03
			Sheet 1 of 3



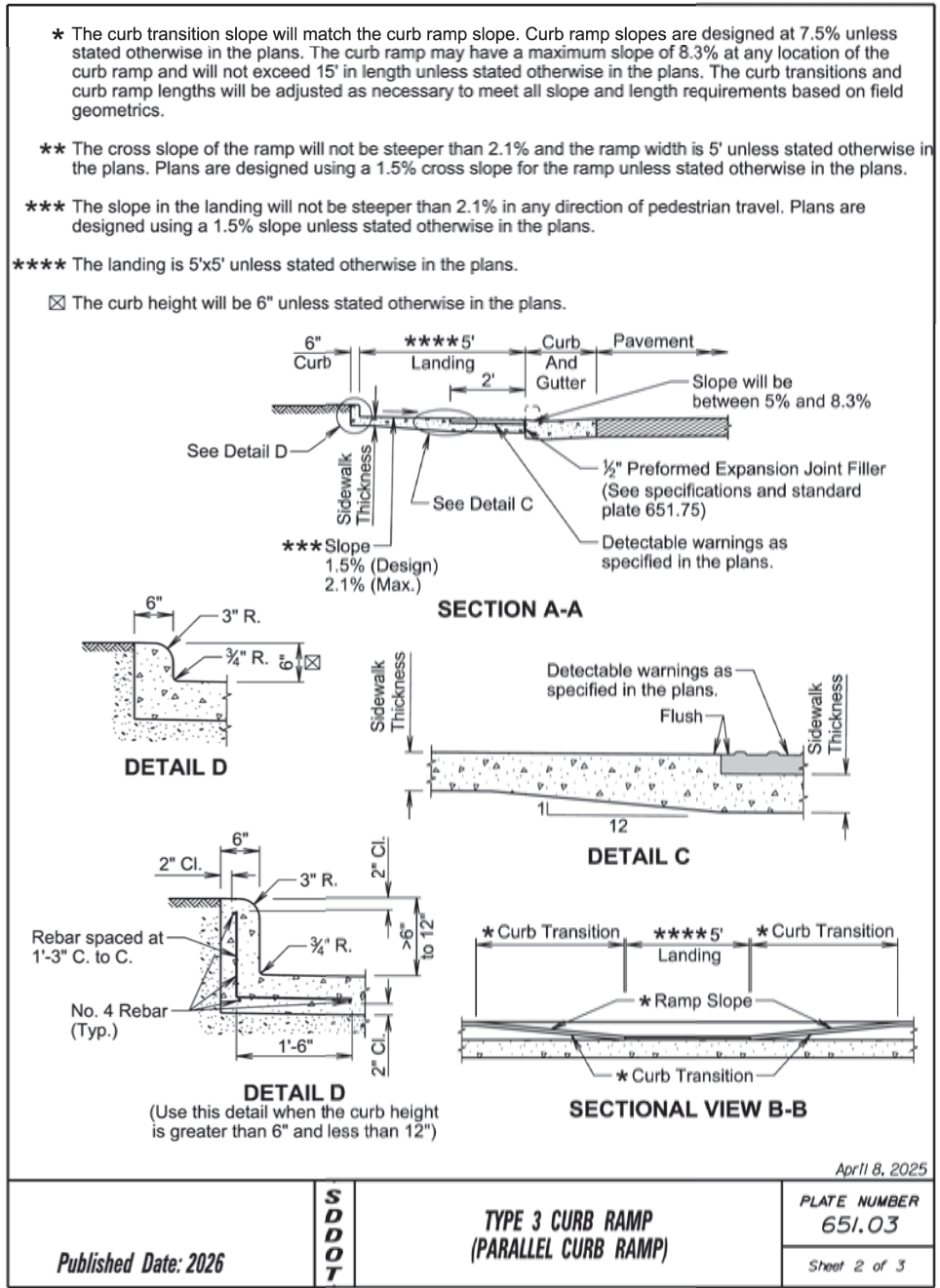

GENERAL NOTES:

For illustrative purpose only, type 1 detectable warnings are shown in the drawings.

For illustrative purpose only, a PCC fillet section is shown in one of the drawings. The curb ramp depicted on this standard plate may be used with a PCC fillet section or with curb and gutter.

The curb ramp will be placed at the location stated in the plans.

Sidewalk adjacent to the curb ramp will be as shown in the plans.

* Care will be taken to ensure a uniform grade on the curb ramp, free of sags and short grade changes.

Surface texture of the curb ramp will be obtained by coarse brooming transverse to the slope of the curb ramp.

The normal gutter line profile will be maintained through the area of the ramp opening.

Joints will be sawed or tooled into the concrete adjacent to the detectable warnings to alleviate possible corner cracking (see plan view for joint location).

Care will be taken to ensure that the surface of the detectable warnings are clean and maintains a uniform color.

The detectable warnings will be cut as necessary to fit the plan specified limits of the detectable warnings. Cost for cutting the detectable warnings will be incidental to the corresponding detectable warning contract item.

When curb height is greater than 6" and less than 12", reinforcing steel is required in accordance with the detail on sheet 2 of 3. The reinforcing steel will conform to ASTM A615, Grade 60. Cost for furnishing and installing the reinforcing steel will be incidental to the contract unit price per square foot for the corresponding concrete sidewalk contract item.

There will be no separate payment for curb ramps. The curb ramp will be measured and paid for at the contract unit price per square foot for the corresponding concrete sidewalk contract item. The square foot area of the detectable warnings and the curb along the short radius will be included in the measured and paid for quantity of sidewalk.

The curb transitions and ramp opening will be measured and paid for at the contract unit price per foot for the corresponding curb and gutter contract item when curb and gutter is used. The curb transitions and ramp opening will be measured and paid for at the contract unit price per square yard for the corresponding PCC fillet section contract item when a PCC fillet section is used.

Type 1 detectable warnings will be measured to the nearest square foot. All costs for furnishing and installing type 1 detectable warnings including labor, equipment, materials, and incidentals will be paid for at the contract unit price per square foot for "Type 1 Detectable Warnings".

Type 2 detectable warnings will be measured to the nearest square foot. All costs for furnishing and installing type 2 detectable warnings including labor, equipment, and materials, including adhesive, necessary sealant or grout, and necessary grinding will be paid for at the contract unit price per square foot for "Type 2 Detectable Warnings".

Published Date: 2026, SDOT, TYPE 3 CURB RAMP (PARALLEL CURB RAMP), PLATE NUMBER 651.03, Sheet 3 of 3, April 8, 2025





PROJECT	SHEET	TOTAL SHEETS
P TAPU(47)	59	112

ELEVATION VIEW (PCC Sidewalk without Boulevard)

ELEVATION VIEW (PCC Sidewalk with Boulevard)

PLAN VIEW

GENERAL NOTES:

The PCC sidewalk will be constructed in accordance with Section 651 of the Specifications.

*** The cross slope of the sidewalk is designed at 1.5% and the maximum slope allowed is 2.1% unless specified otherwise in the plans.

The maximum length between expansion joints in the PCC sidewalk is 75 feet.

PCC sidewalk placed adjacent to intersection of roadways will have an expansion joint placed transversely a maximum of 37.5 feet from the intersection. See Plan View.

An expansion joint in the PCC sidewalk will consist of a 1/2 -inch thick preformed expansion joint filler material placed full depth and width of the PCC sidewalk.

** Large areas of PCC pavement adjacent to the PCC sidewalk may require a different joint treatment than shown in the detail. If a different joint detail is necessary, plans will contain the joint detail and the Contractor will construct the joint treatment in accordance with the plans.

Apr 11 8, 2025

Published Date: 2026	SD DOT	PCC SIDEWALK	PLATE NUMBER
			651.75
			Sheet 1 of 2

ELEVATION VIEW (PCC sidewalk adjacent to asphalt concrete pavement)

ELEVATION VIEW (PCC sidewalk adjacent to earthen material, landscape rock, or other compressible materials)

ELEVATION VIEW (PCC sidewalk adjacent to building or other rigid structure)

ELEVATION VIEW (PCC sidewalk adjacent to PCC pavement)

DETAIL A
(Use Appropriate Detail(s))

Apr 11 8, 2025

Published Date: 2026	SD DOT	PCC SIDEWALK	PLATE NUMBER
			651.75
			Sheet 2 of 2



Spacing Varies (See Table)

Flow

See Detail B

Slope	Spacing (Ft.)
1:1	10
2:1	20
3:1	30
4:1	40

ELEVATION VIEW
(Cut or Fill Slope Installation)

Excavated Material from Trench

Flow

Wood Stake

DETAIL B
(Typical of All Installations)

Ends of Erosion Control Wattles

Wood Stake

DETAIL C
(See General Notes)

Point A

Point B

Flow

Wood Stake (Typ.)

ISOMETRIC VIEW
(Ditch Installation)

Point A

Point B

Flow

Wood Stake (Typ.)

PLAN VIEW
(Ditch Installation)

Point A

Point B

Flow

Wood Stake

SECTION A-A

Grade	Spacing (Ft.)
2%	150
3%	100
4%	75
5%	50

February 14, 2020

Published Date: 2026	SD DOT	EROSION CONTROL WATTLE	PLATE NUMBER
			734.06
			Sheet 1 of 2

GENERAL NOTES:

At cut or fill slope installations, wattles will be installed along the contour and perpendicular to the water flow.

At ditch installations, point A must be higher than point B to ensure that water flows over the wattle and not around the ends.

The Contractor will dig a 3" to 5" trench, install the wattle tightly in the trench so that daylight can not be seen under the wattle, and then compact the soil excavated from the trench against the wattle on the uphill side. See Detail B.

The stakes will be 1"x2" or 2"x2" wood stakes, however, other types of stakes such as rebar may be used only if approved by the Engineer. The stakes will be placed 6" from the ends of the wattles and the spacing of the stakes along the wattles will be 3' to 4'.

Where installing running lengths of wattles, the Contractor will butt the second wattle tightly against the first and will not overlap the ends. See Detail C.

The Contractor and Engineer will inspect the erosion control wattles in accordance with the storm water permit. The Contractor will remove, dispose, or reshape the accumulated sediment when necessary as determined by the Engineer.

Sediment removal, disposal, or necessary shaping will be as directed by the Engineer. All costs for removing accumulated sediment, disposal of sediment, and necessary shaping will be incidental to the contract unit price per cubic yard for "Remove Sediment".

All costs for furnishing and installing the erosion control wattles including labor, equipment, and materials will be incidental to the contract unit price per foot for the corresponding erosion control wattle contract item.

All costs for removing the erosion control wattle from the project including labor, equipment, and materials will be incidental to the contract unit price per foot for "Remove Erosion Control Wattle".

February 14, 2020

Published Date: 2026	SD DOT	EROSION CONTROL WATTLE	PLATE NUMBER
			734.06
			Sheet 2 of 2

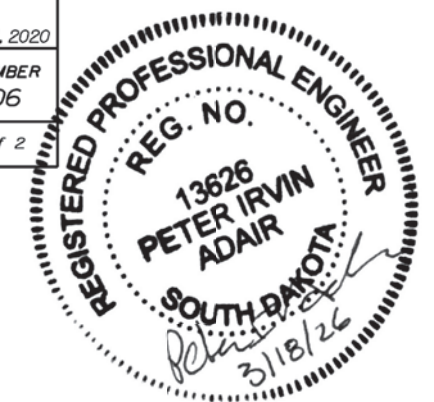

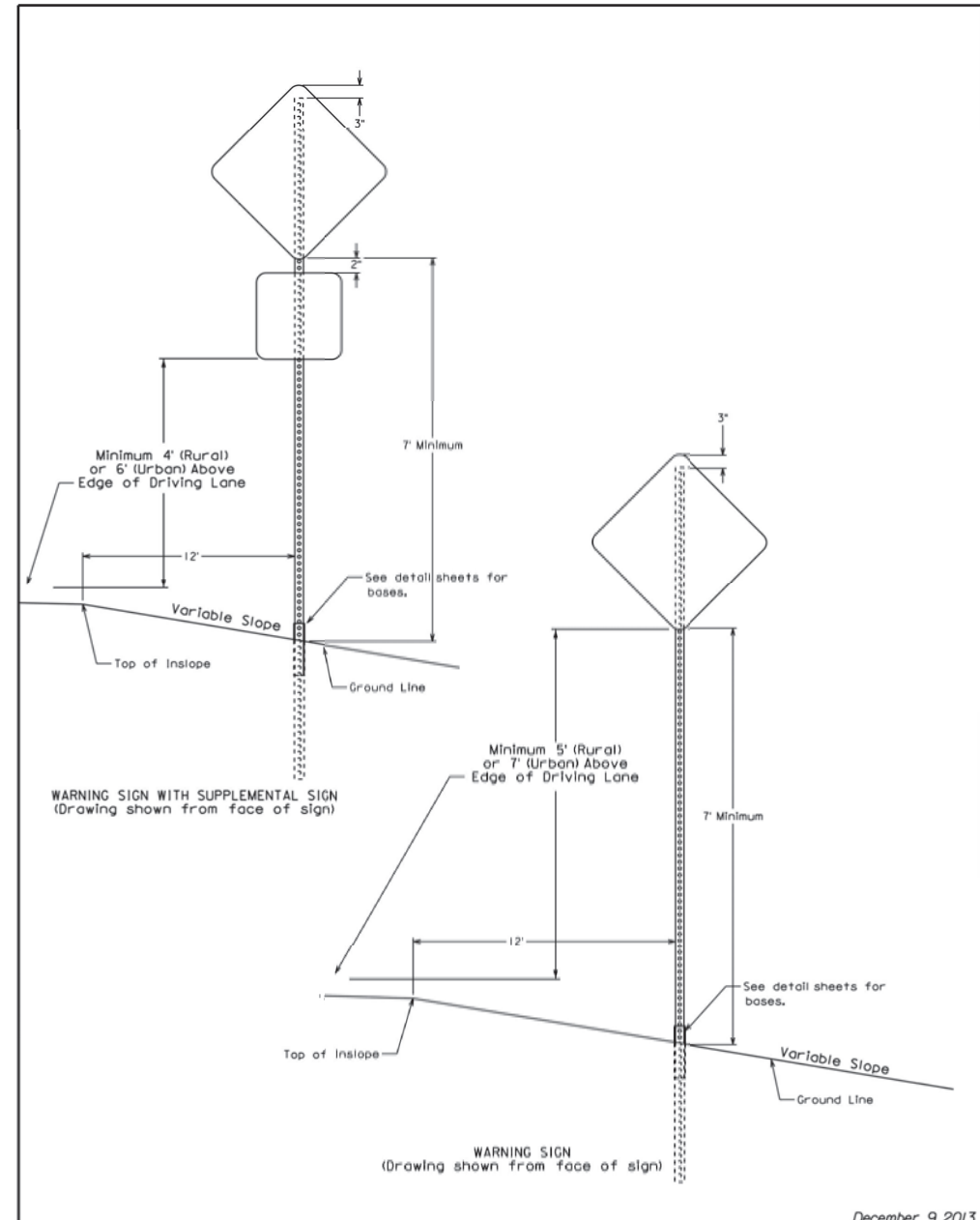

December 9, 2013

SD DOT	30" WARNING SIGNS (Typical Sign Detail)	SPECIAL DETAIL LO1
		Sheet 1 of 1

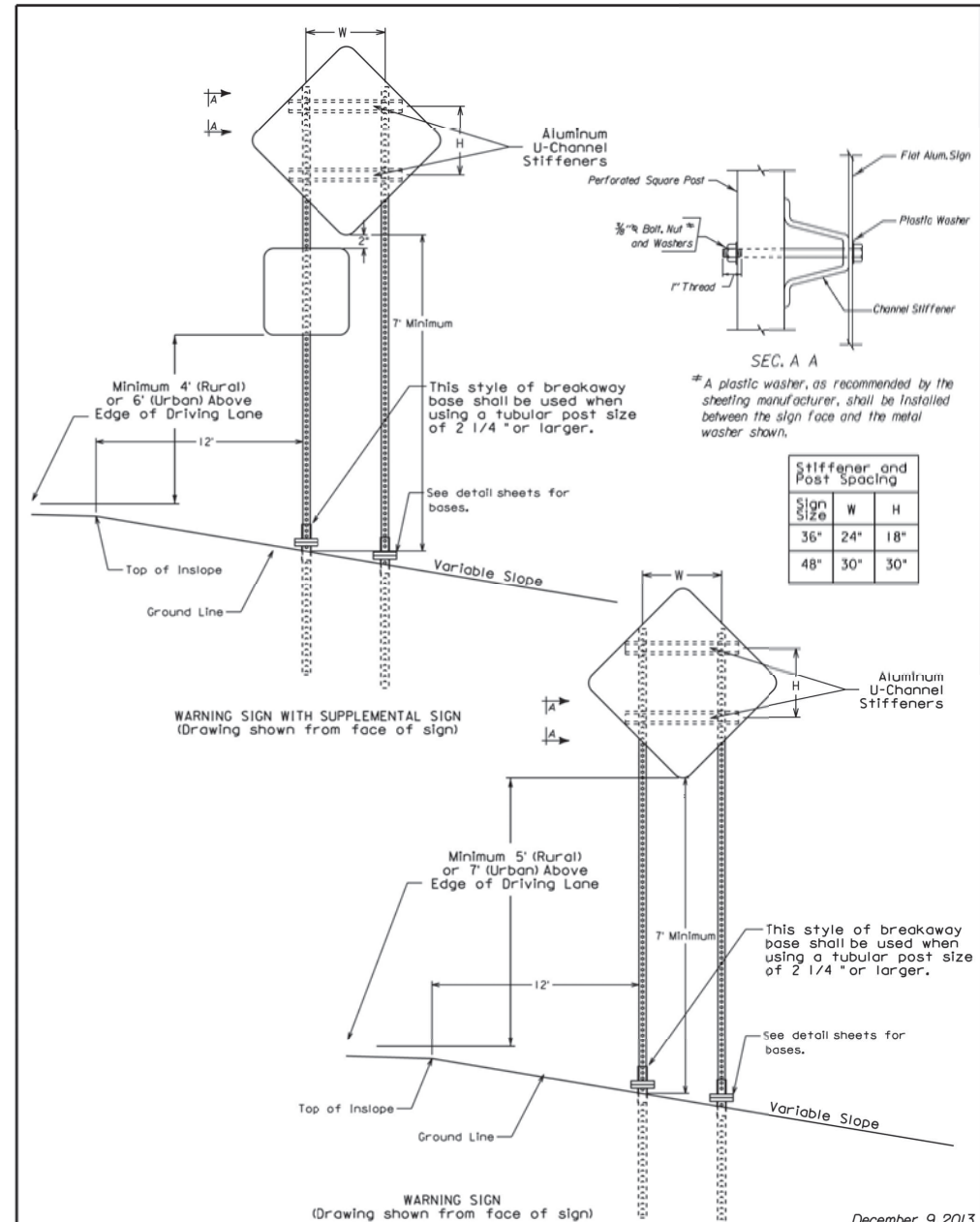

December 9, 2013

SD DOT	36" AND 48" WARNING SIGNS (Typical Sign and Stiffener Detail)	SPECIAL DETAIL LO2
		Sheet 1 of 1



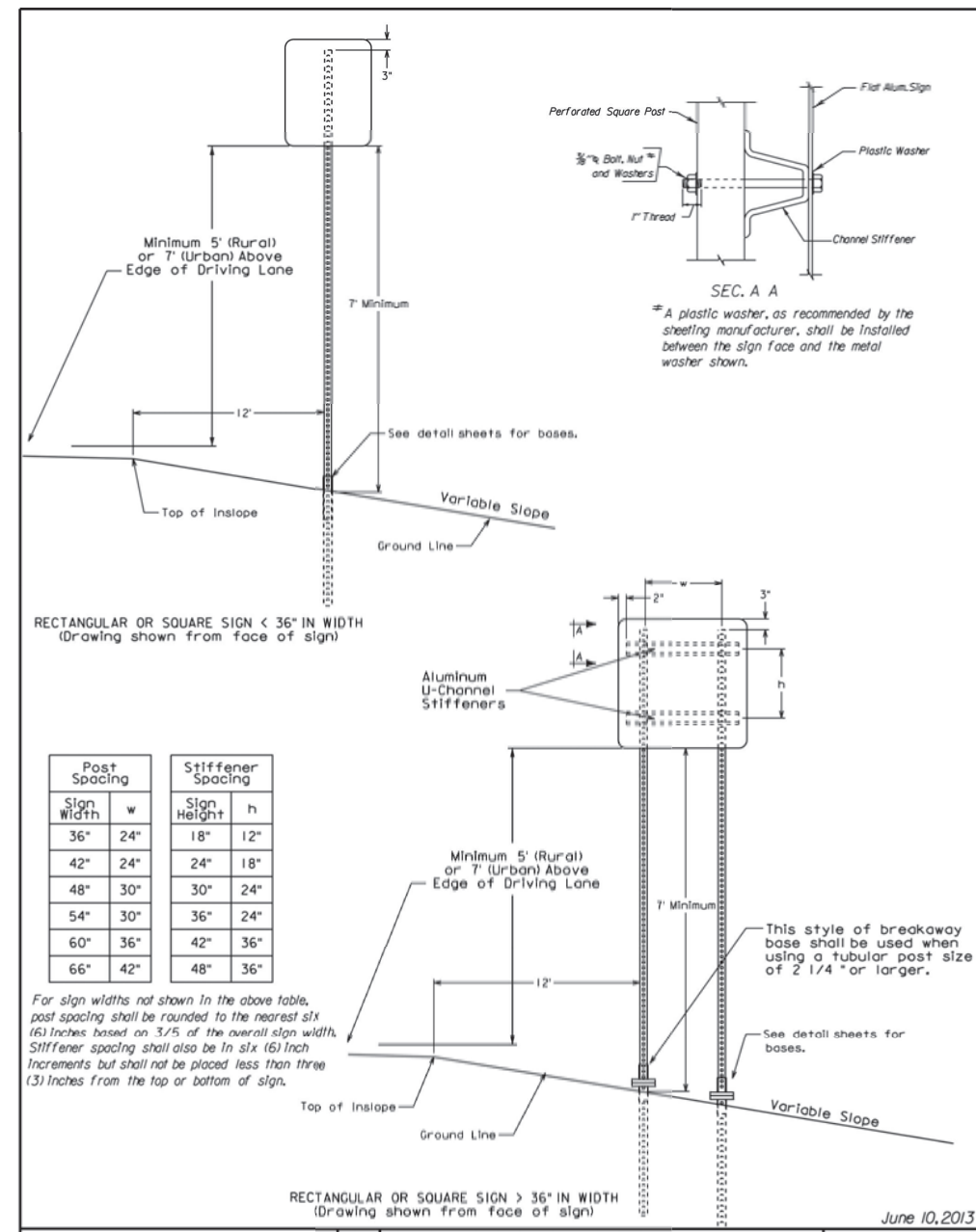

SDOT

SQUARE OR RECTANGULAR SIGNS
(Typical Sign and Stiffener Details)

SPECIAL DETAIL
L03

Sheet 1 of 1

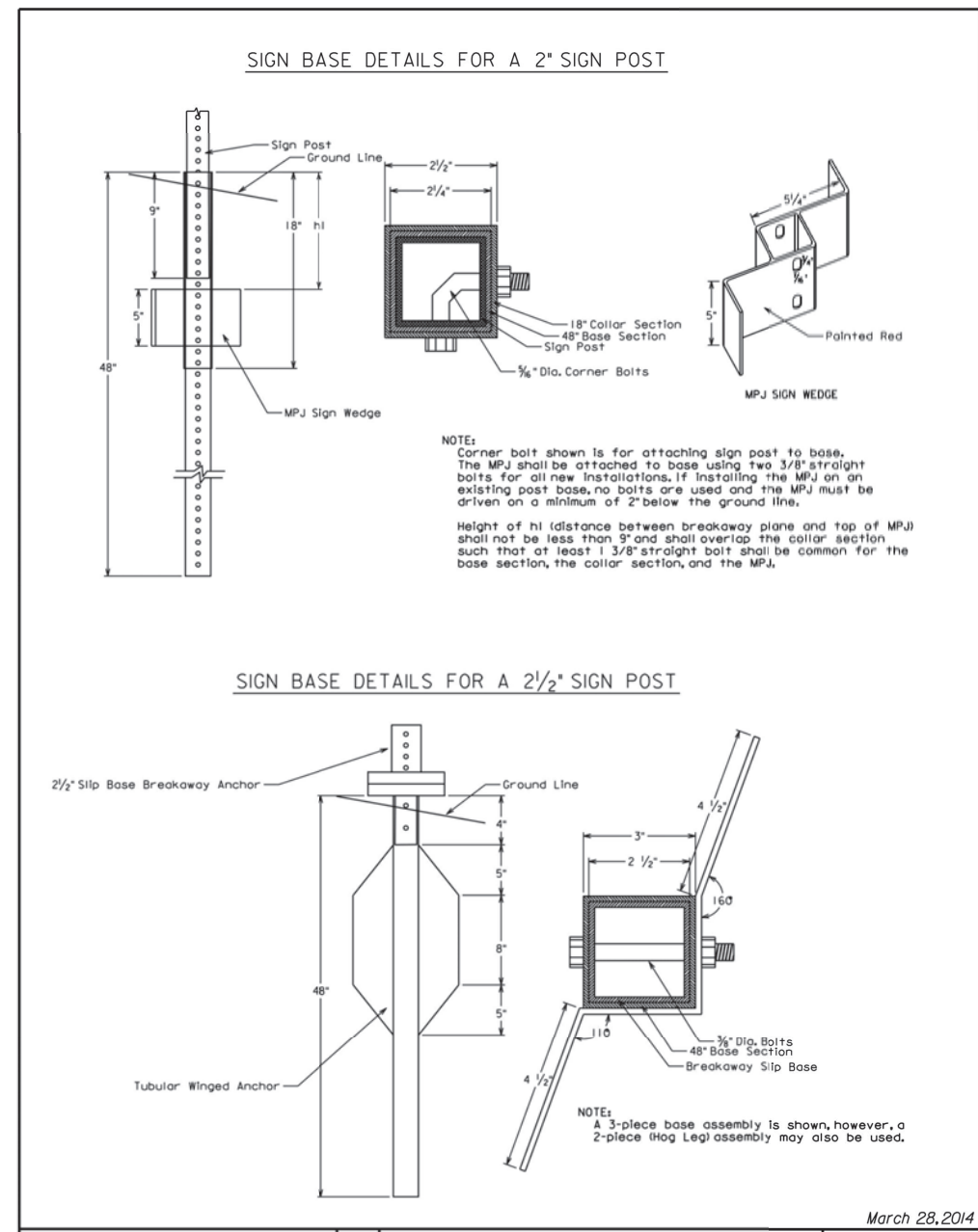

SDOT

TUBULAR POST BASE DETAILS
(Typical Soil Installation)

SPECIAL DETAIL
L21

Sheet 1 of 1



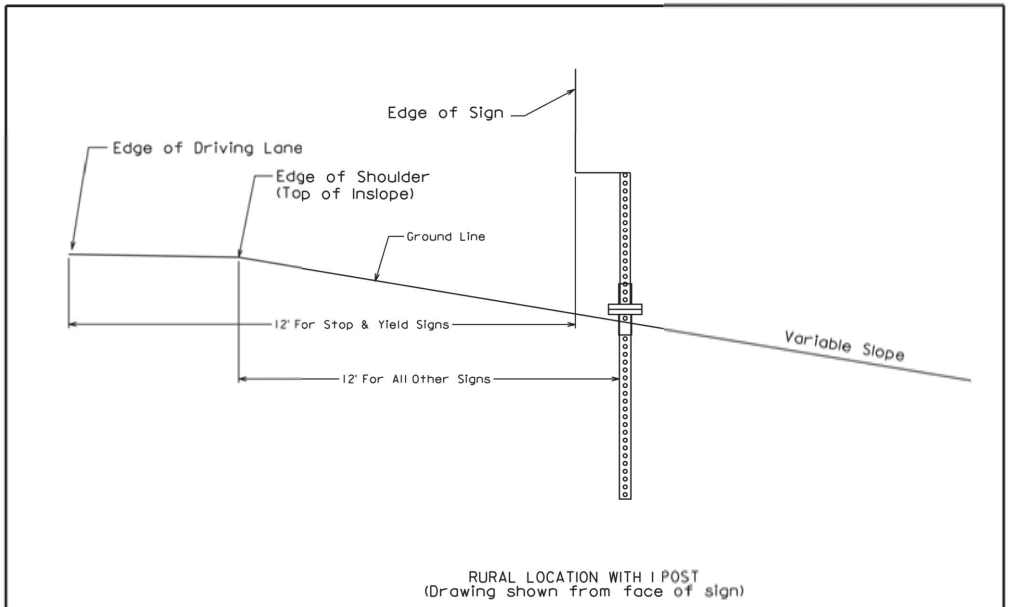

RURAL LOCATION WITH 1 POST
(Drawing shown from face of sign)

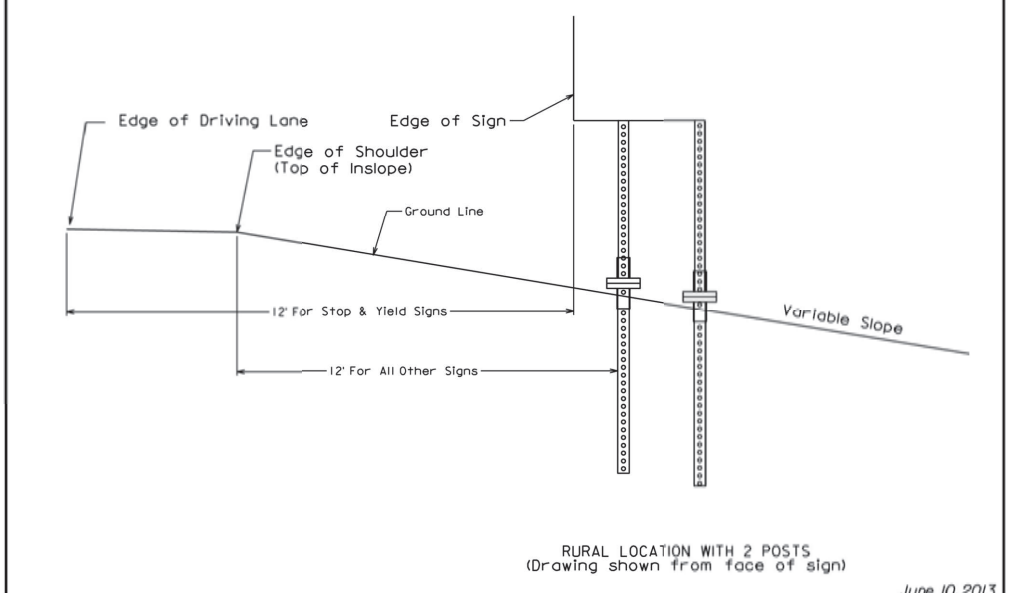

RURAL LOCATION WITH 2 POSTS
(Drawing shown from face of sign)

June 10, 2013

SD DOT	LATERAL OFFSET <i>(Typical Rural Sign Installations)</i>	SPECIAL DETAIL L23
		Sheet 1 of 1

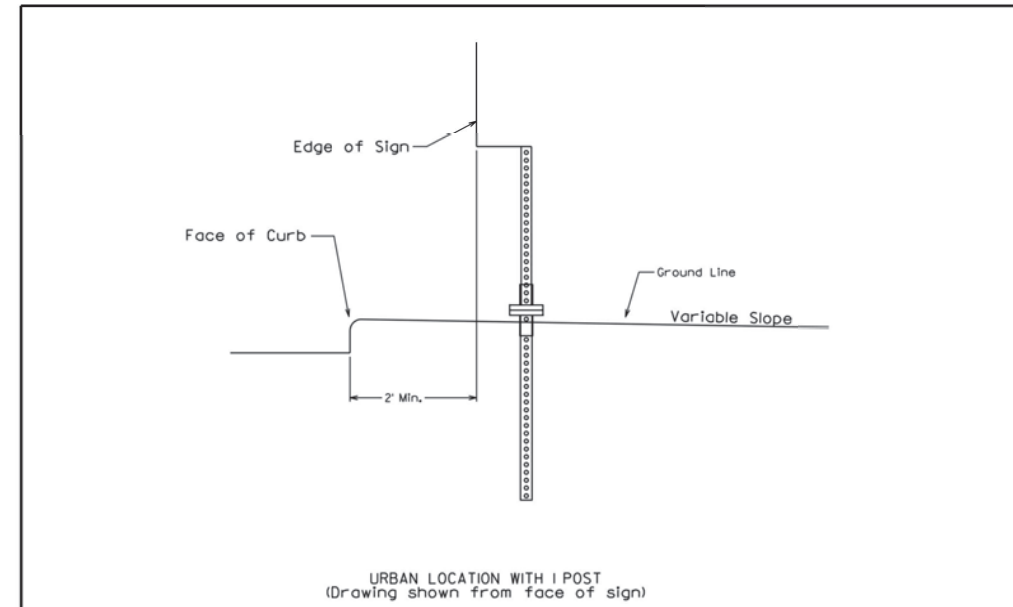

URBAN LOCATION WITH 1 POST
(Drawing shown from face of sign)

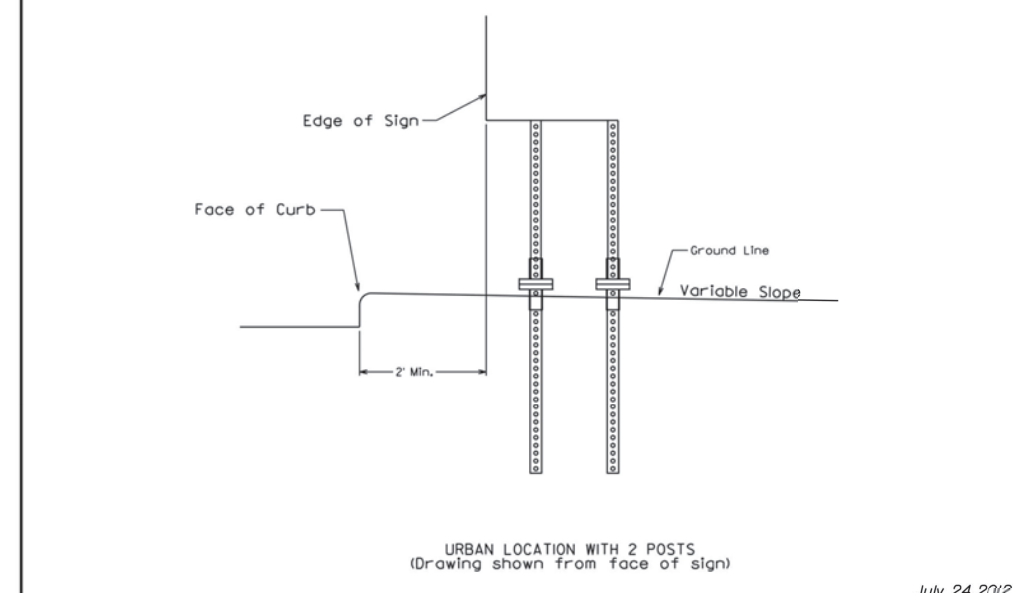

URBAN LOCATION WITH 2 POSTS
(Drawing shown from face of sign)

July 24, 2012

SD DOT	LATERAL OFFSET <i>(Typical Urban Sign Installations)</i>	SPECIAL DETAIL L24
		Sheet 1 of 1





PROJECT	SHEET	TOTAL SHEETS
P TAPU(47)	64	112

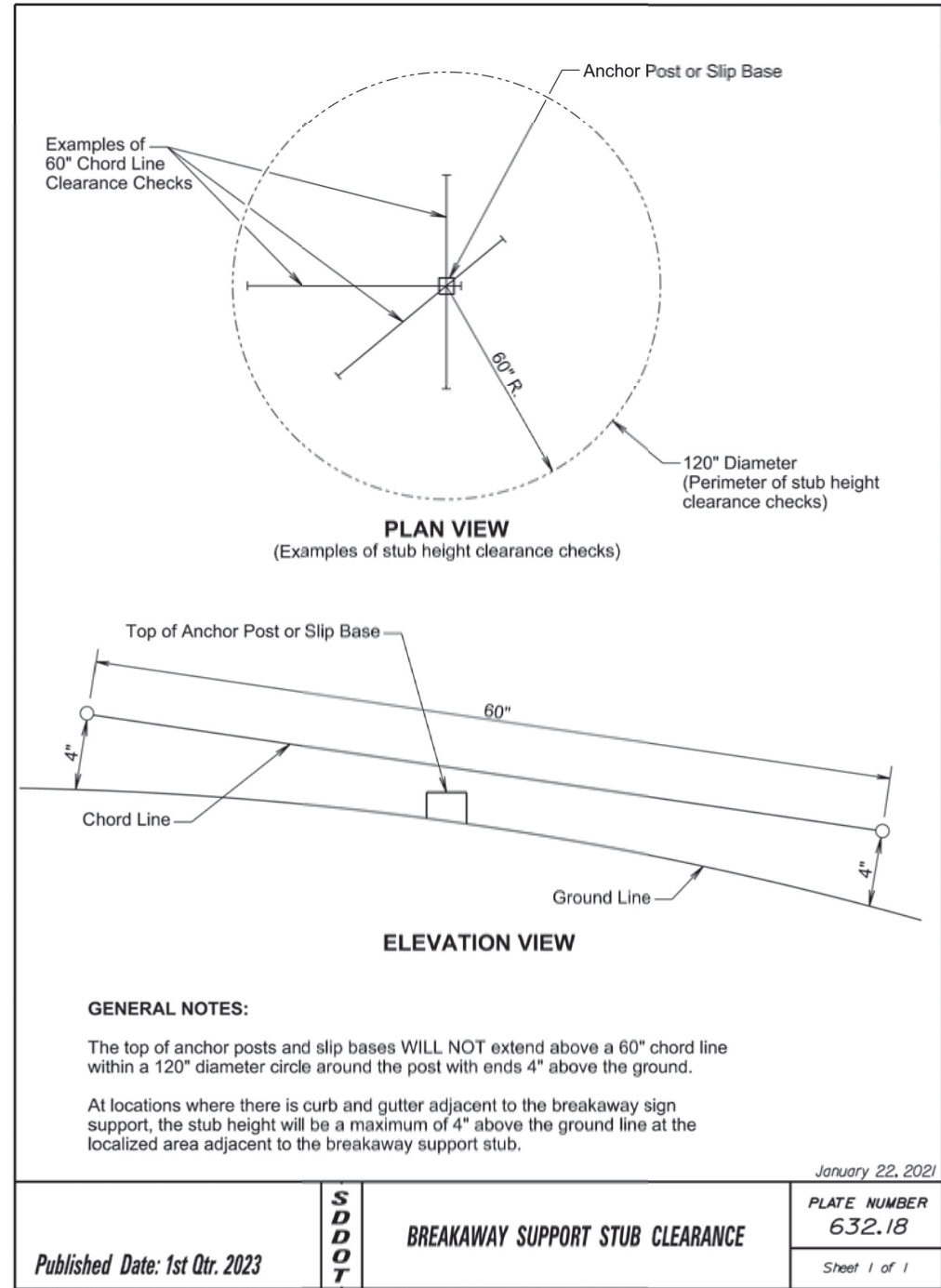

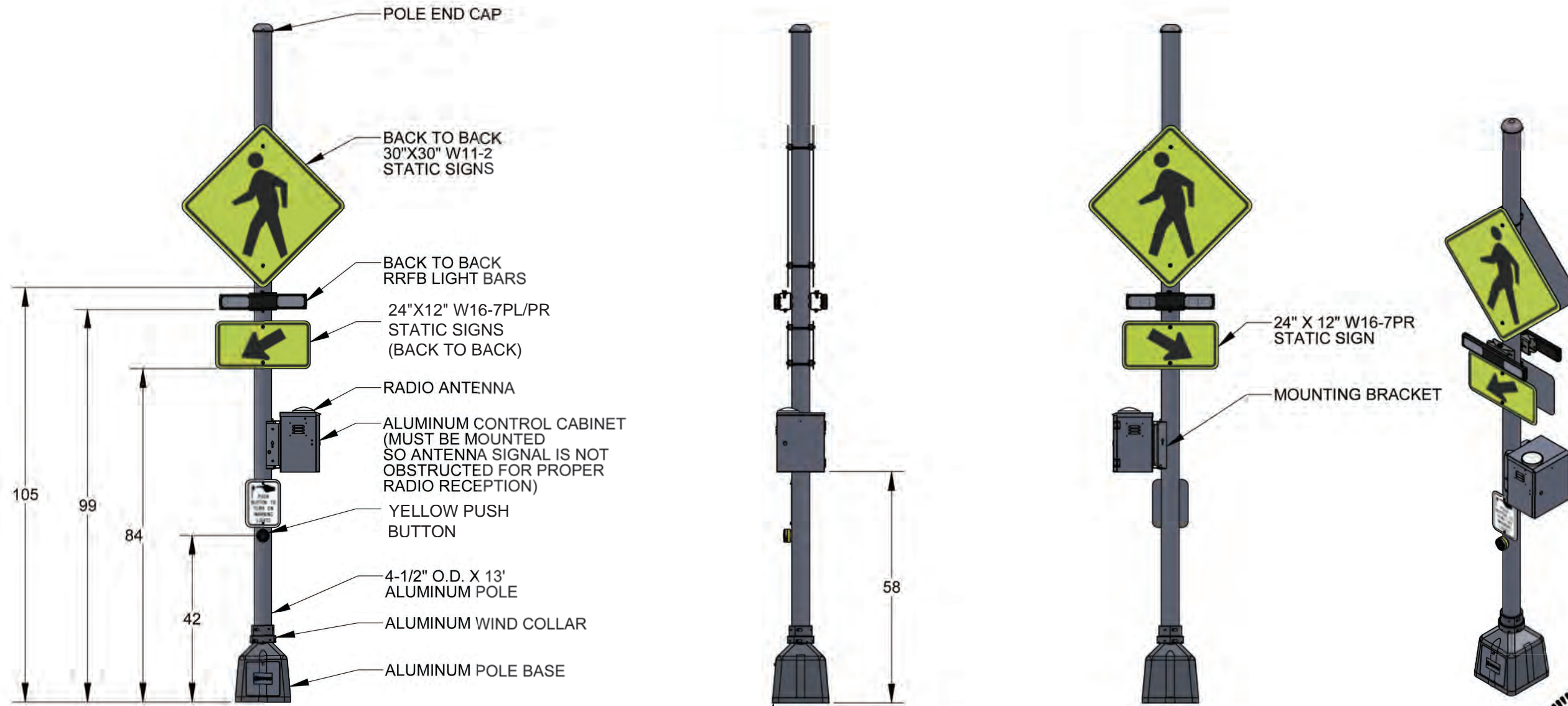

FOOTINGS PER TABLE OR AS REQUIRED BY MANUFACTURER.

NOTES:

- CONTROL CABINET HEIGHT MAY VARY.
- WORM CLAMPS ARE PROVIDED, STANDARD 3/4" S/S BANDING IS RECOMMENDED
- J-BOLTS NOT SHOWN
- ALL DIMENSIONS ARE FOR REFERENCE ONLY.
- FOOTINGS SHALL BE INCIDENTAL TO THE RRFB BID ITEM

TABLE OF FOOTING DATA

Site Designation	Footing Diameter	* Footing Depth	** Spiral Diameter	** Spiral Length	Vertical Reinforcement
C1, C2	2' - 0"	6' - 0"	1' - 8"	44' - 3"	8-#7 x 5' - 6"

* Footing depth will be below ground level

** The size of all spirals will be #3

BY TAPCO OR EQUIVALENT

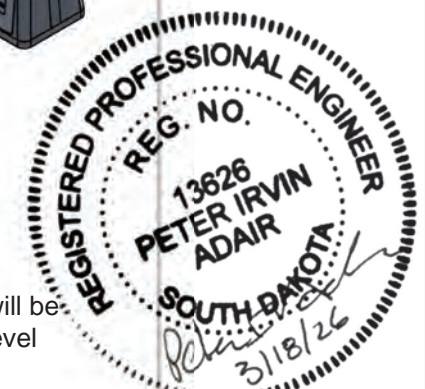

FOR BIDDING PURPOSES ONLY



PROJECT	SHEET	TOTAL SHEETS
P TAPU(47)	67	112

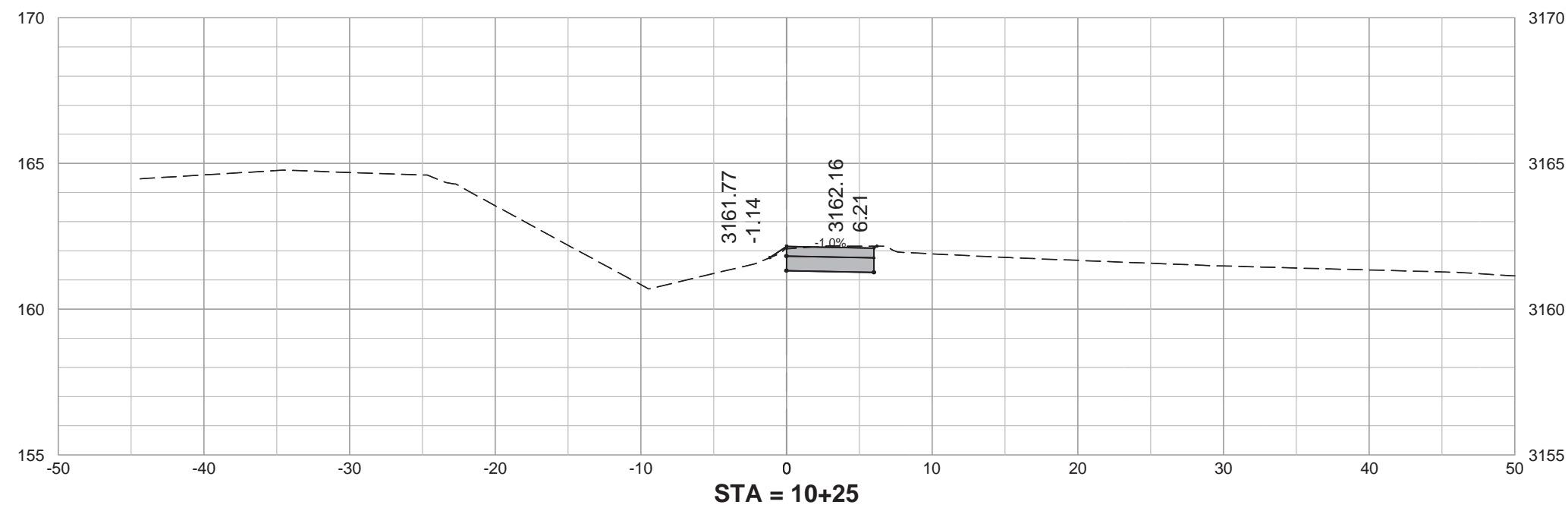
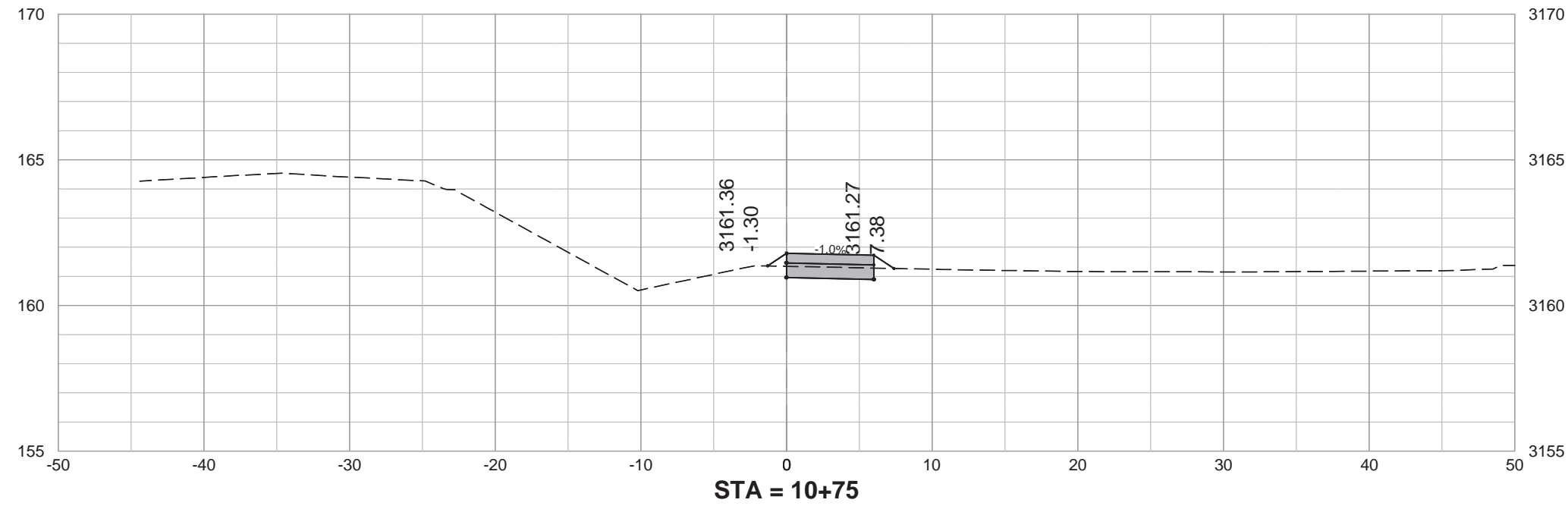

FOR BIDDING PURPOSES ONLY



PROJECT	SHEET	TOTAL SHEETS
P TAPU(47)	68	112

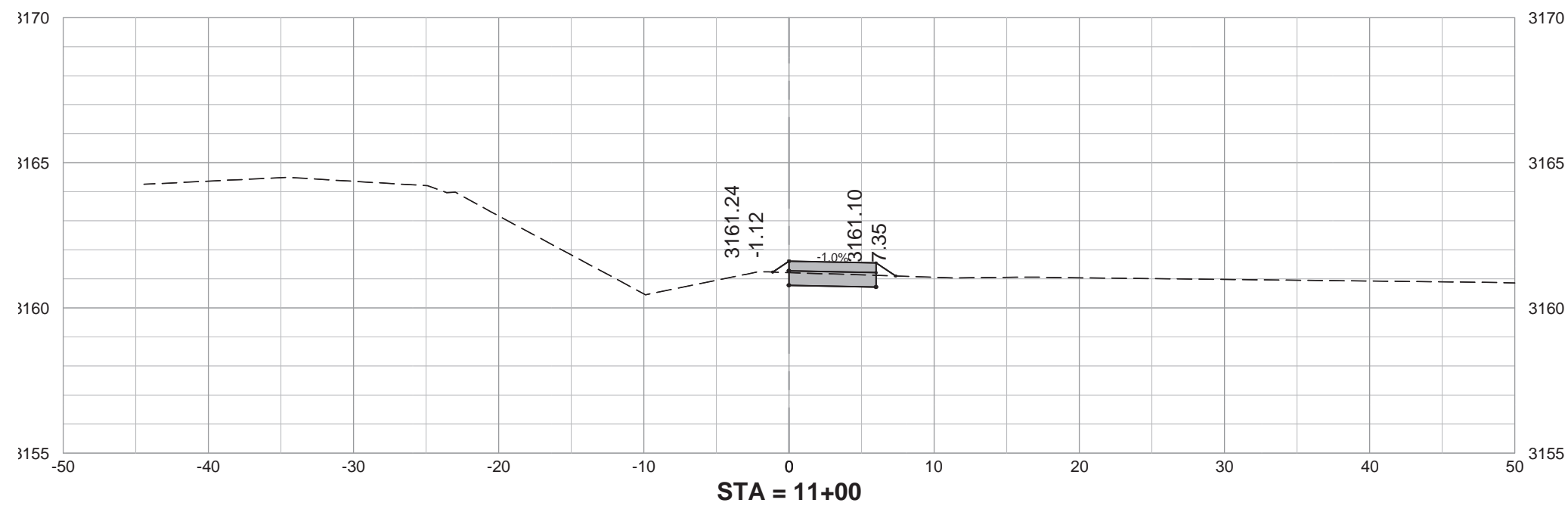
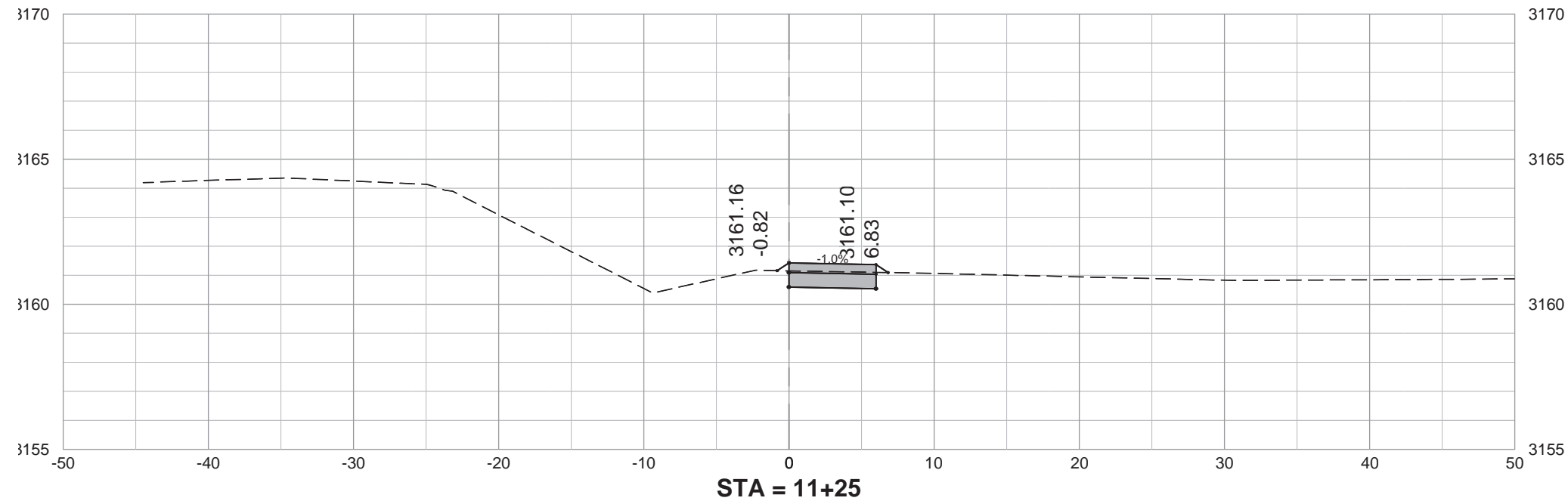

FOR BIDDING PURPOSES ONLY



PROJECT	SHEET	TOTAL SHEETS
P TAPU(47)	69	112

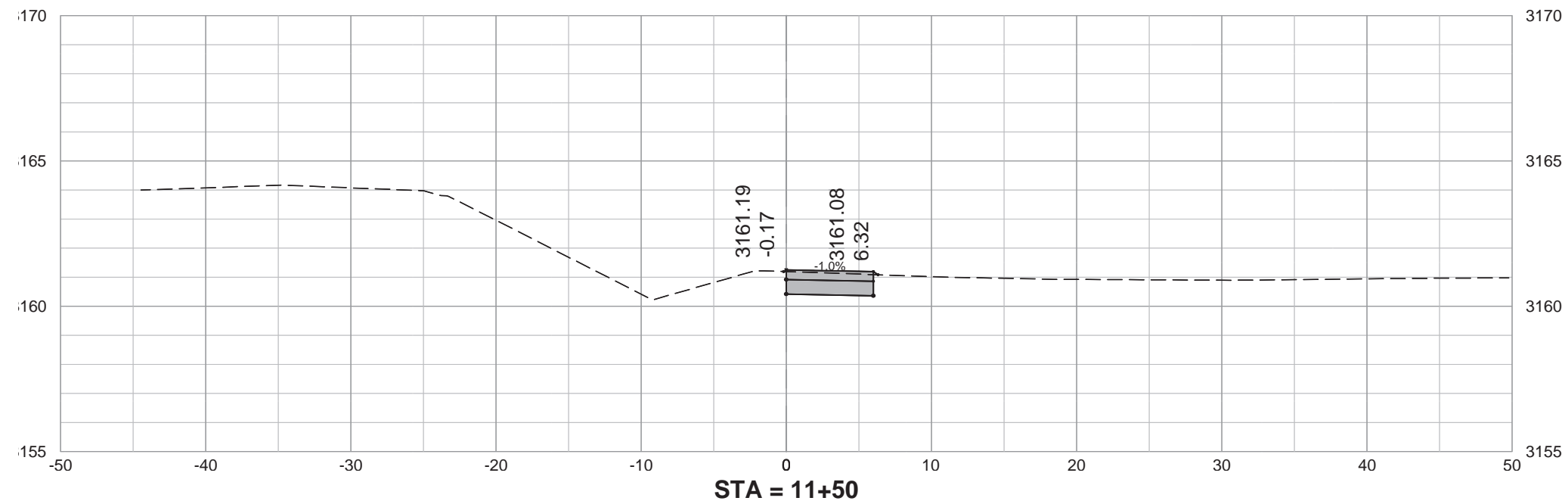
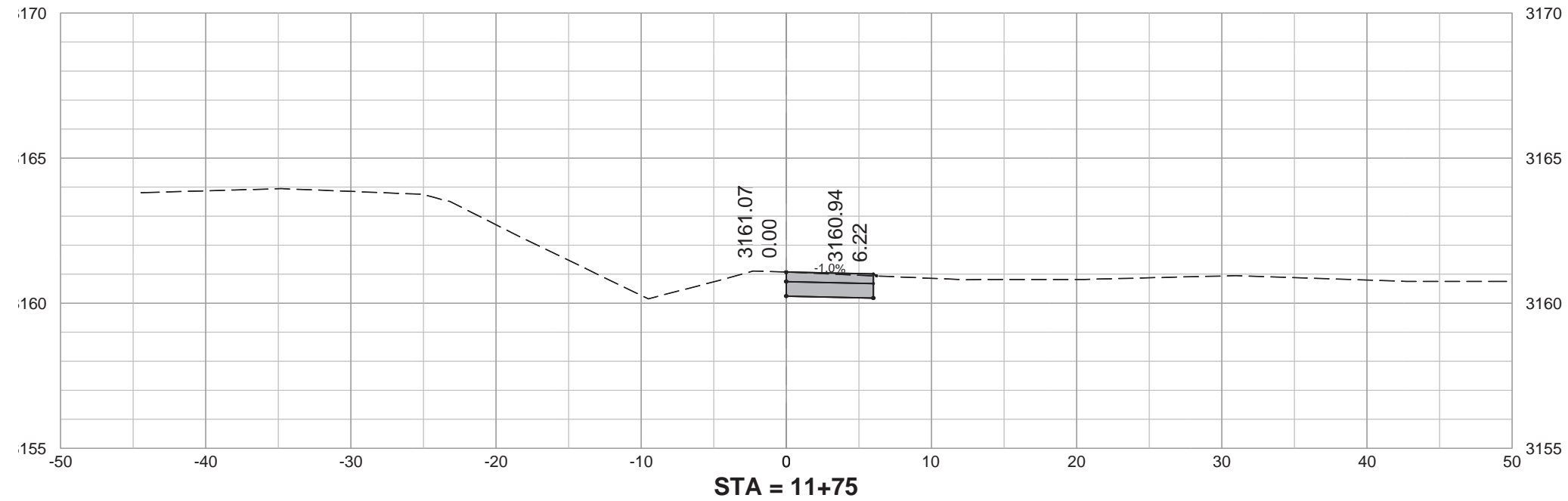

FOR BIDDING PURPOSES ONLY



PROJECT	SHEET	TOTAL SHEETS
P TAPU(47)	70	112

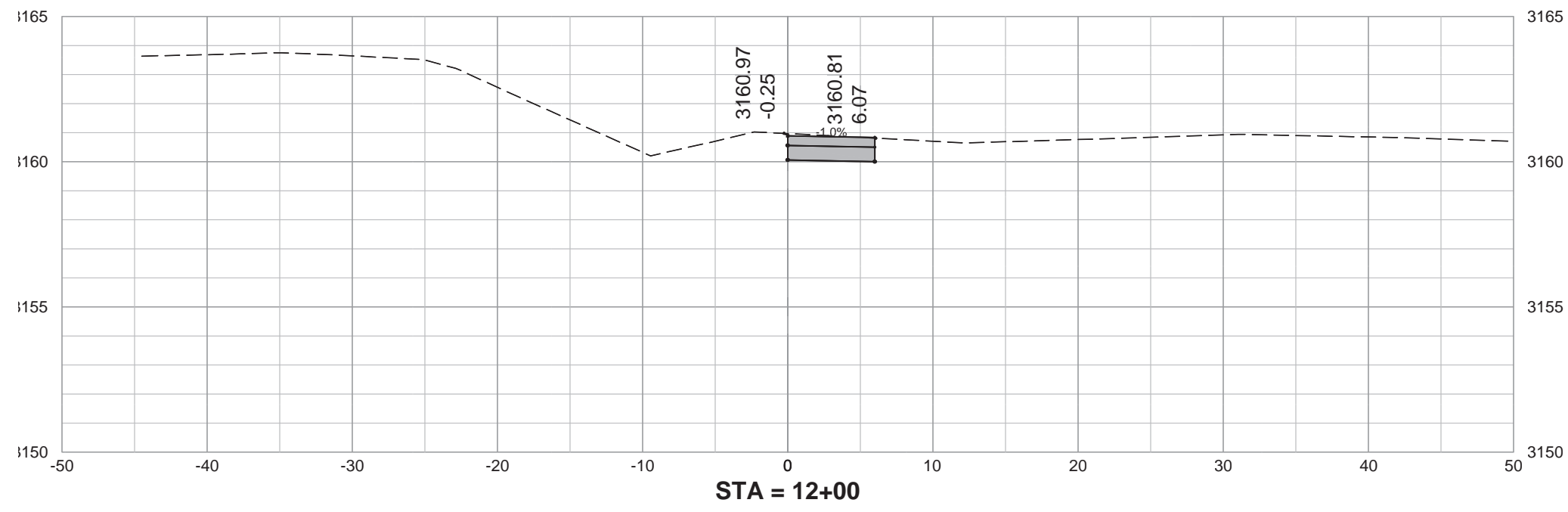
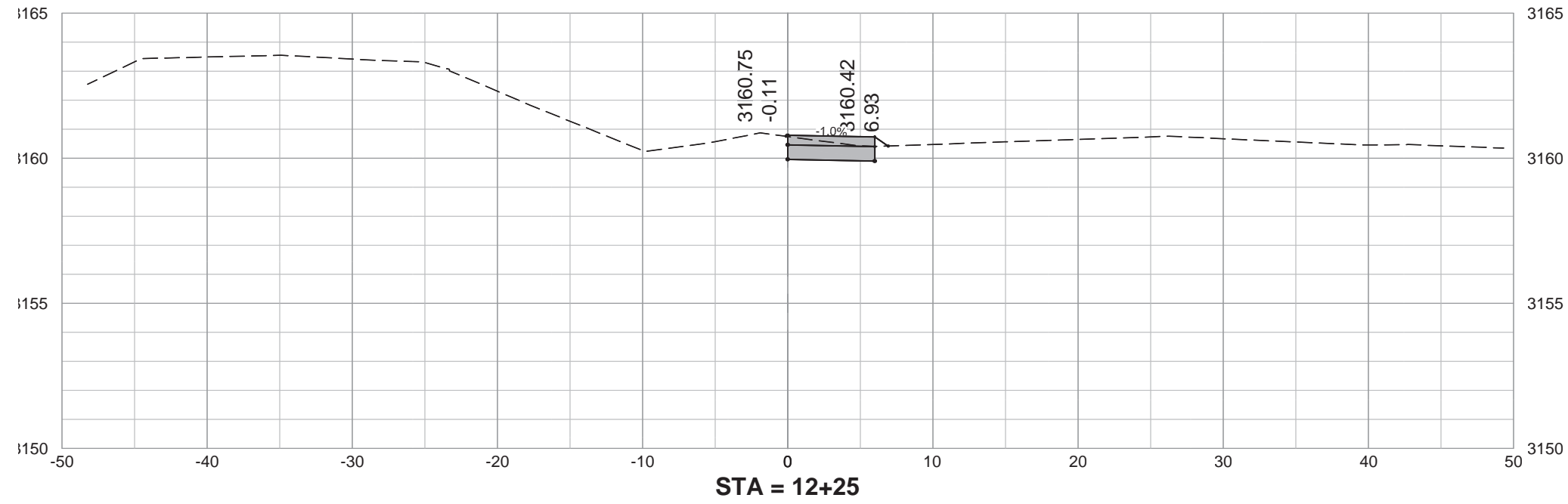

FOR BIDDING PURPOSES ONLY



PROJECT	SHEET	TOTAL SHEETS
P TAPU(47)	71	112

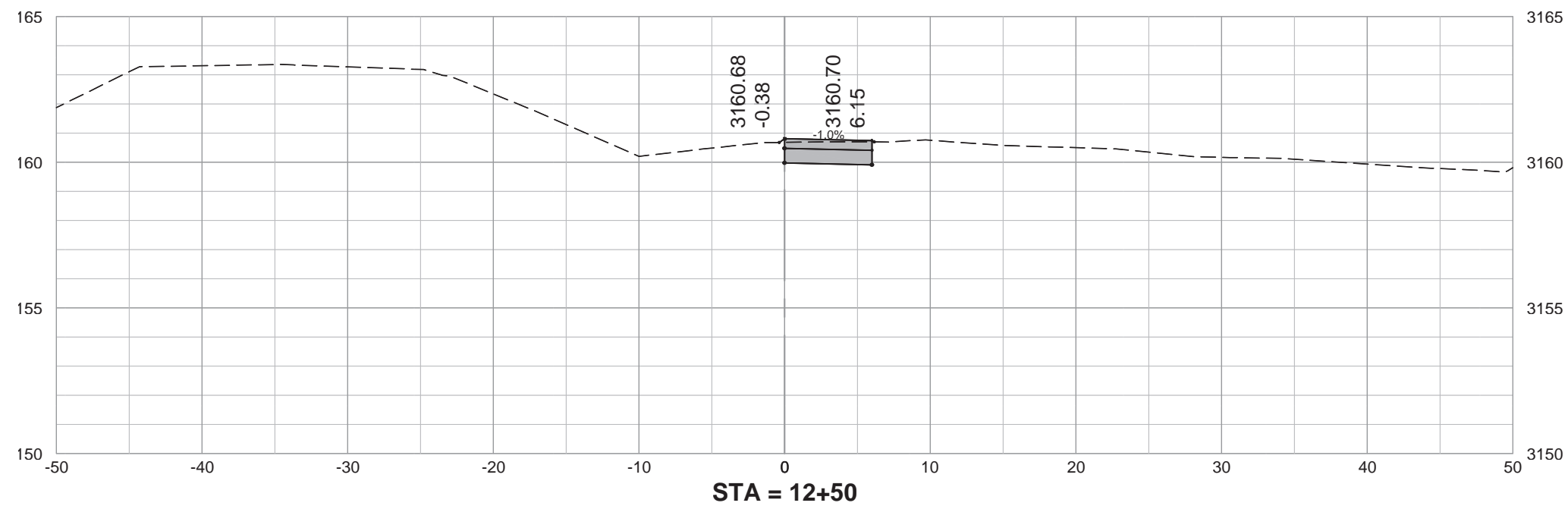
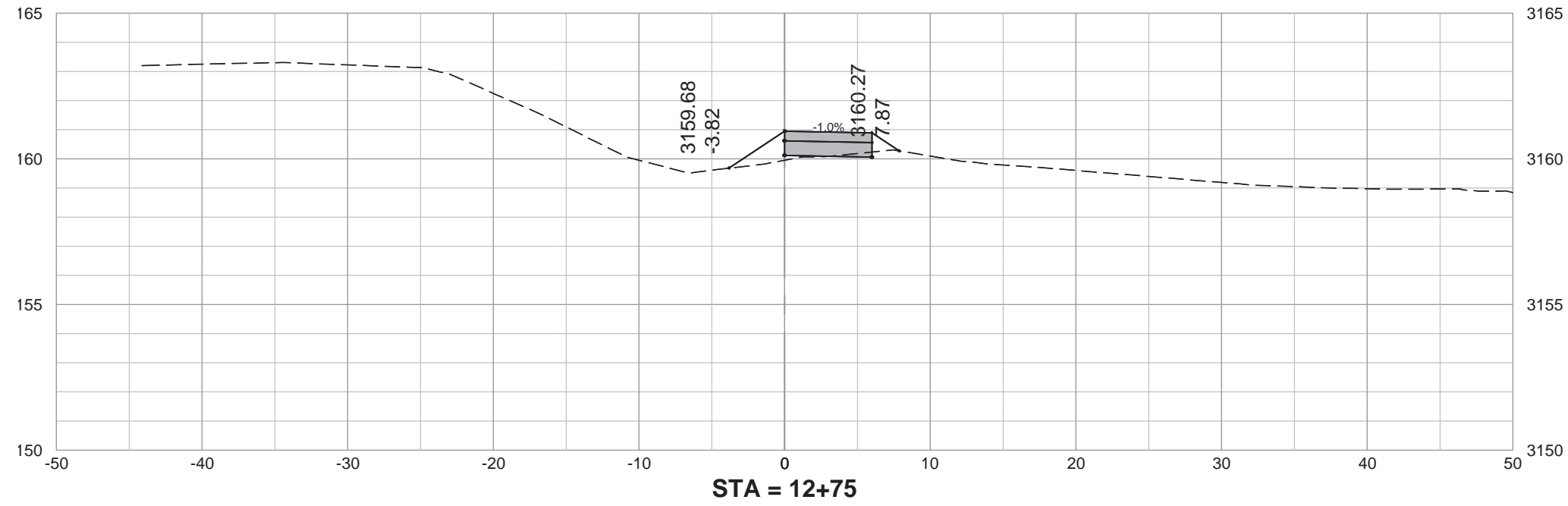

FOR BIDDING PURPOSES ONLY



PROJECT	SHEET	TOTAL SHEETS
P TAPU(47)	72	112

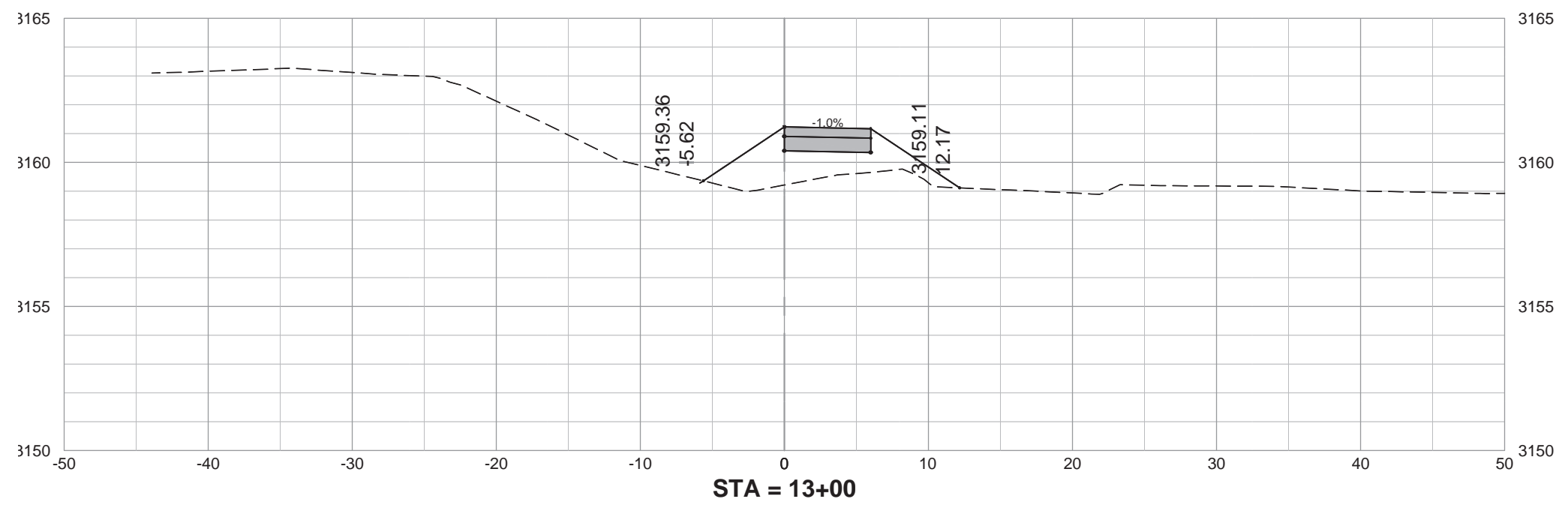
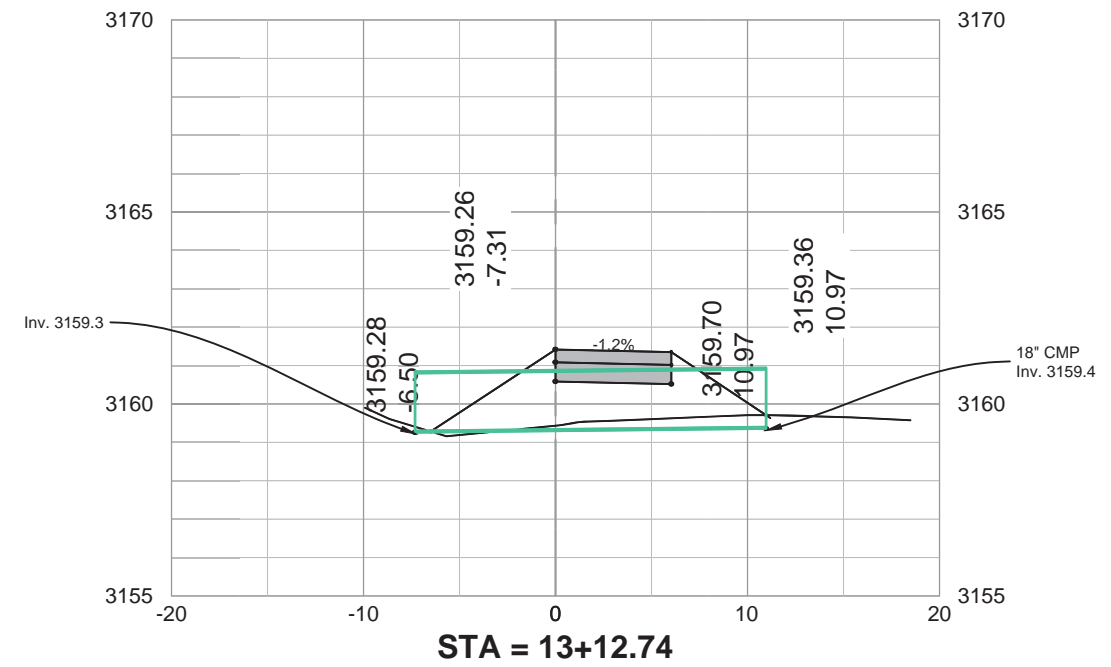

FOR BIDDING PURPOSES ONLY



PROJECT	SHEET	TOTAL SHEETS
P TAPU(47)	73	112

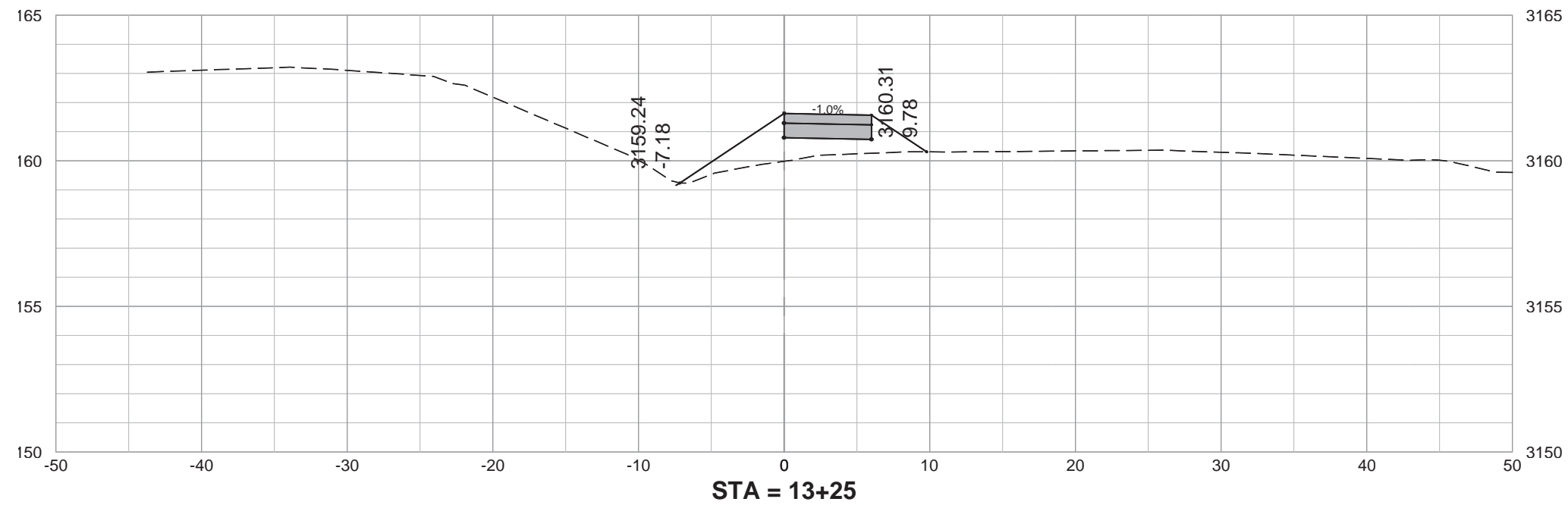
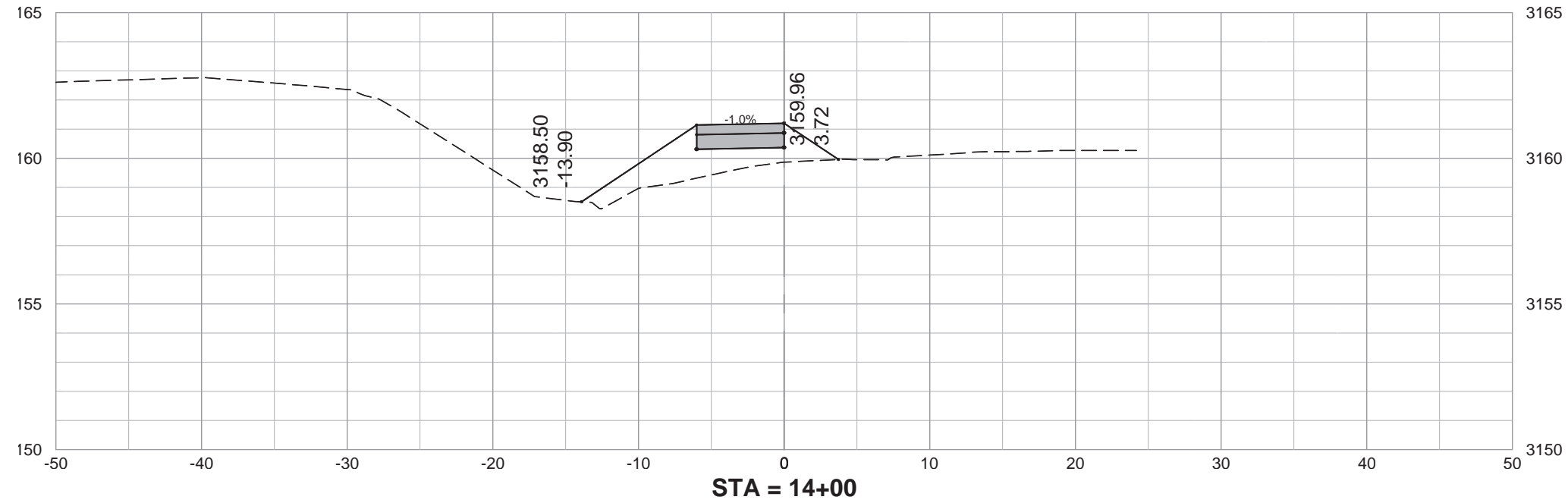

FOR BIDDING PURPOSES ONLY



PROJECT	SHEET	TOTAL SHEETS
P TAPU(47)	74	112

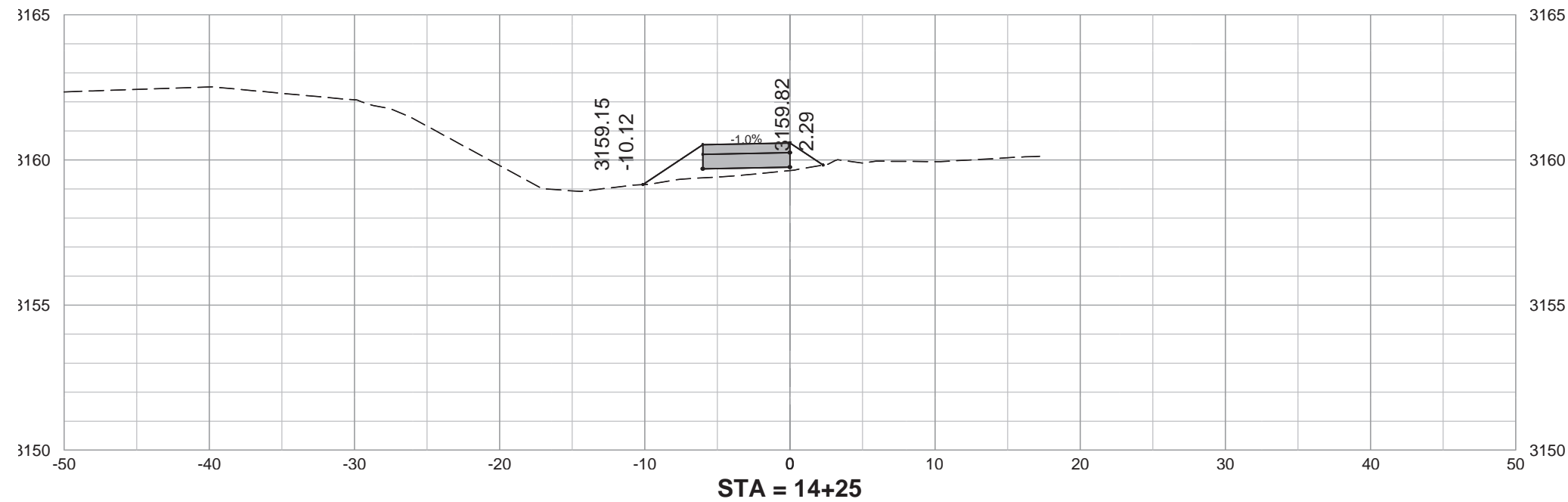
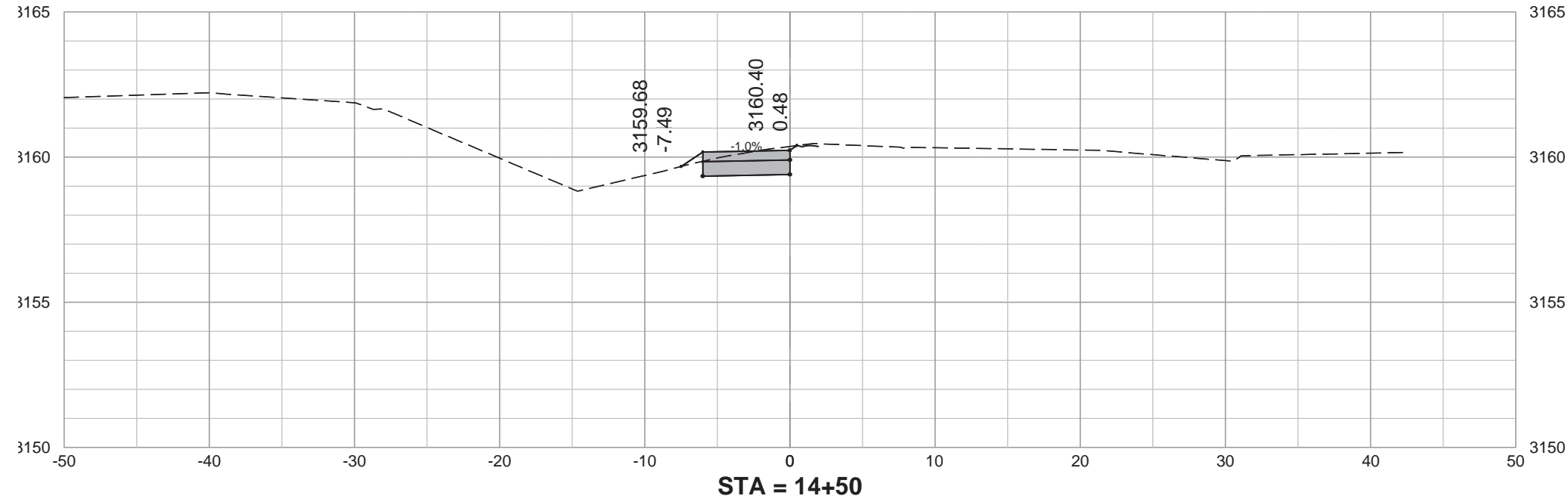

FOR BIDDING PURPOSES ONLY



PROJECT	SHEET	TOTAL SHEETS
P TAPU(47)	75	112

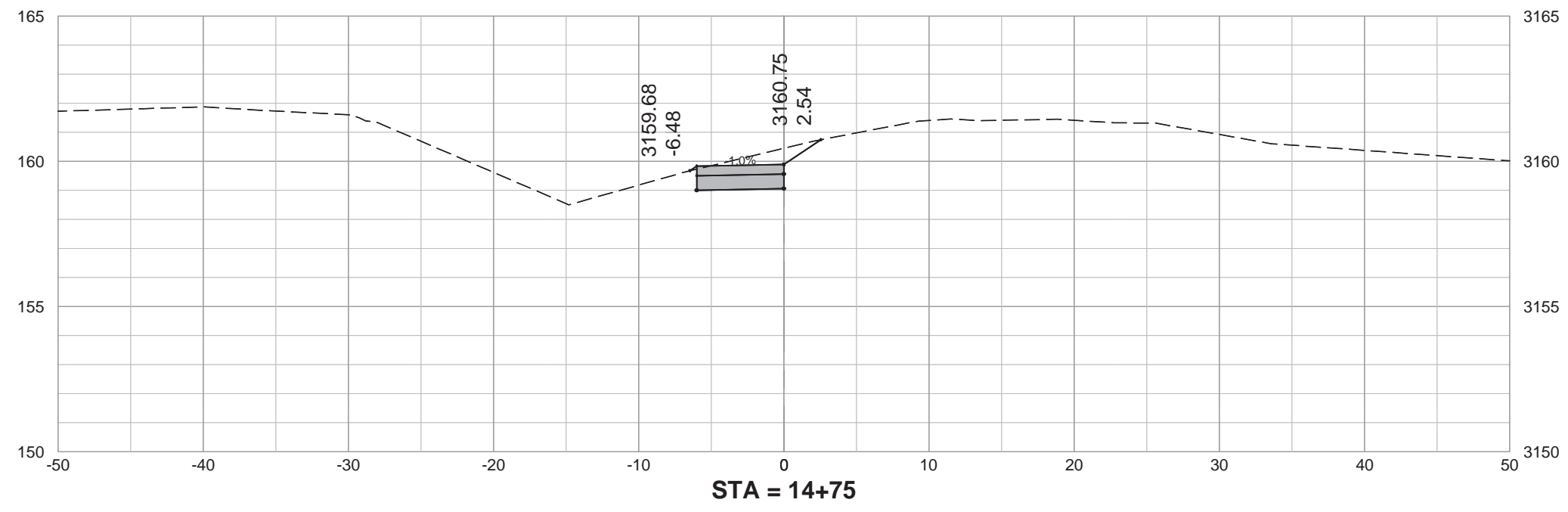
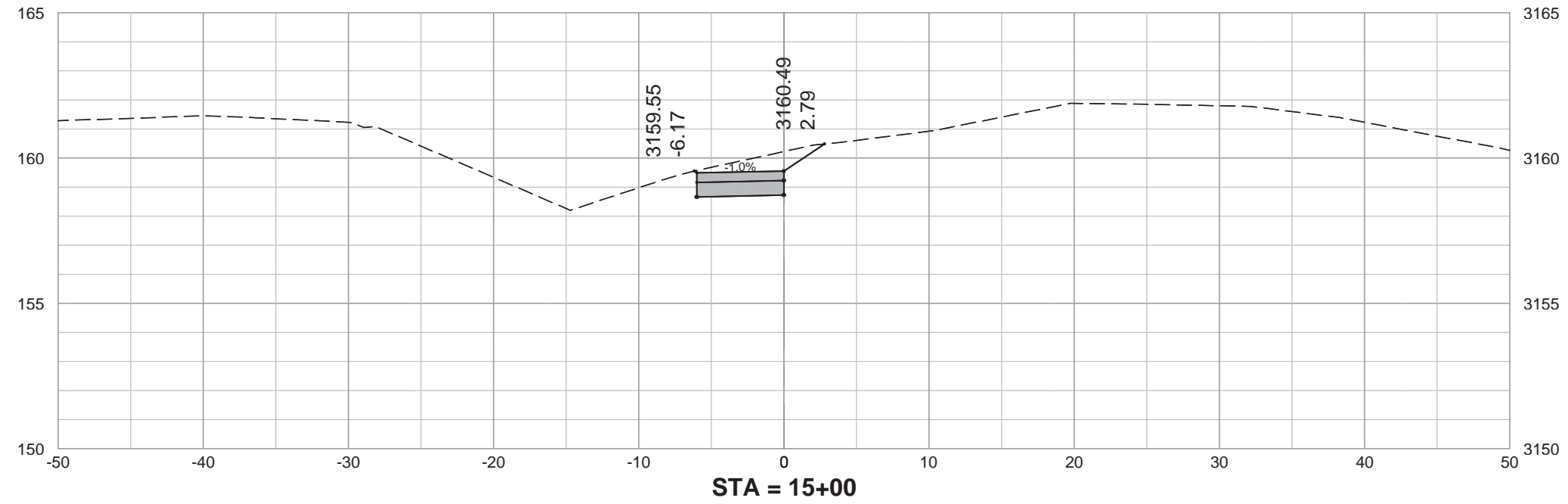

FOR BIDDING PURPOSES ONLY



PROJECT	SHEET	TOTAL SHEETS
P TAPU(47)	76	112

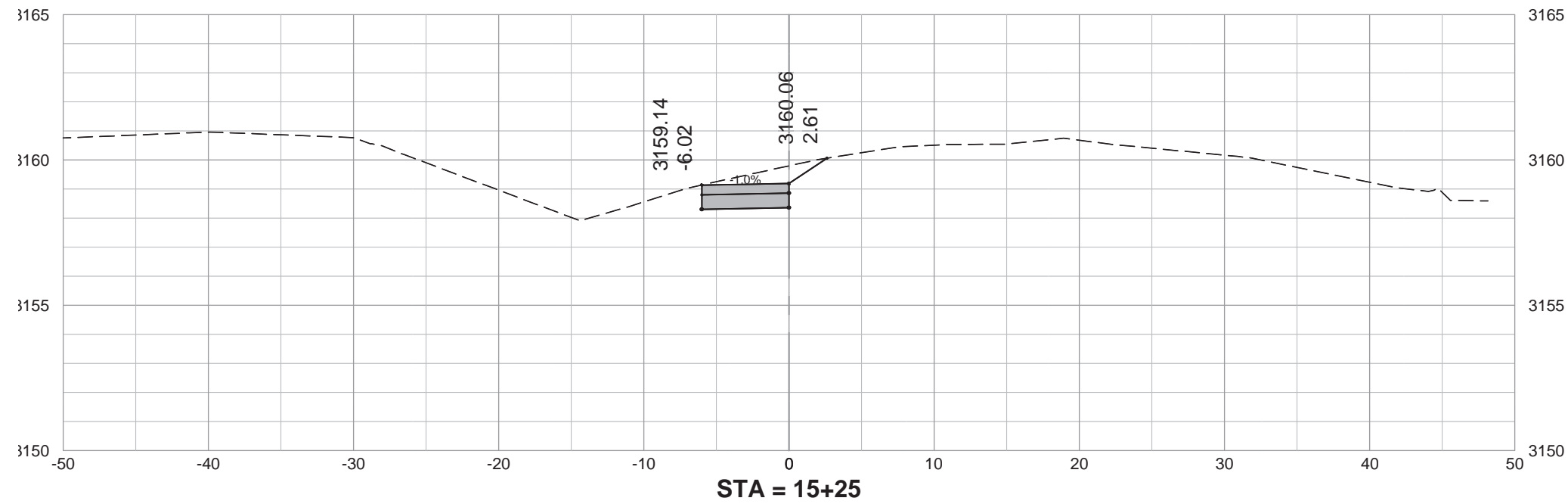
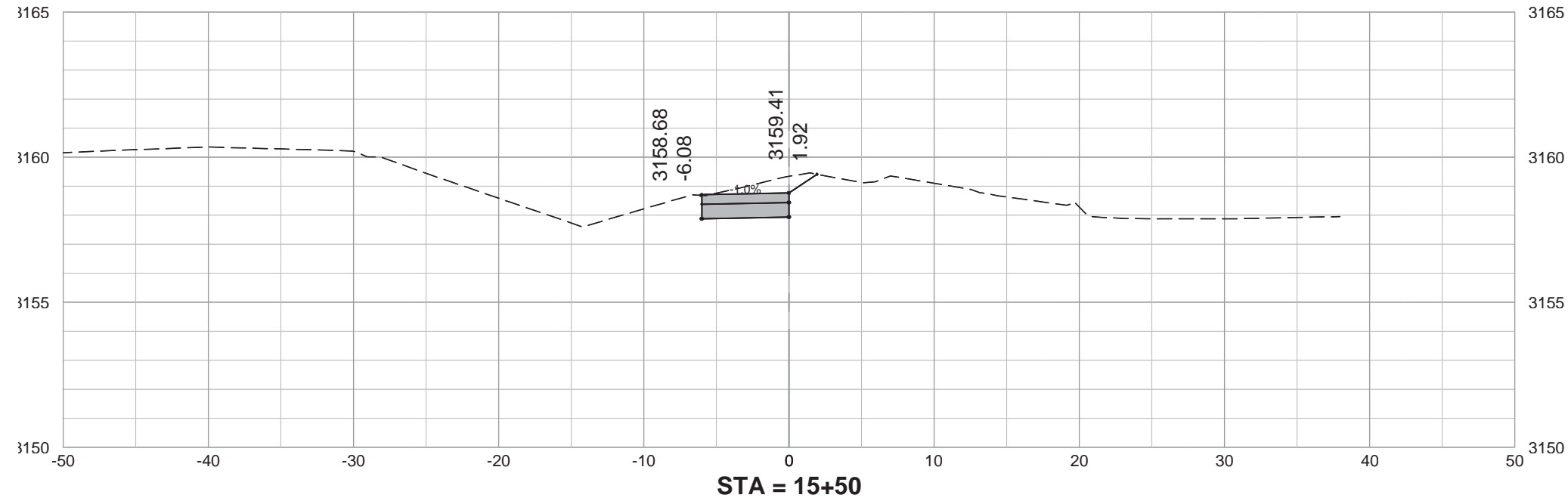

FOR BIDDING PURPOSES ONLY



PROJECT	SHEET	TOTAL SHEETS
P TAPU(47)	77	112

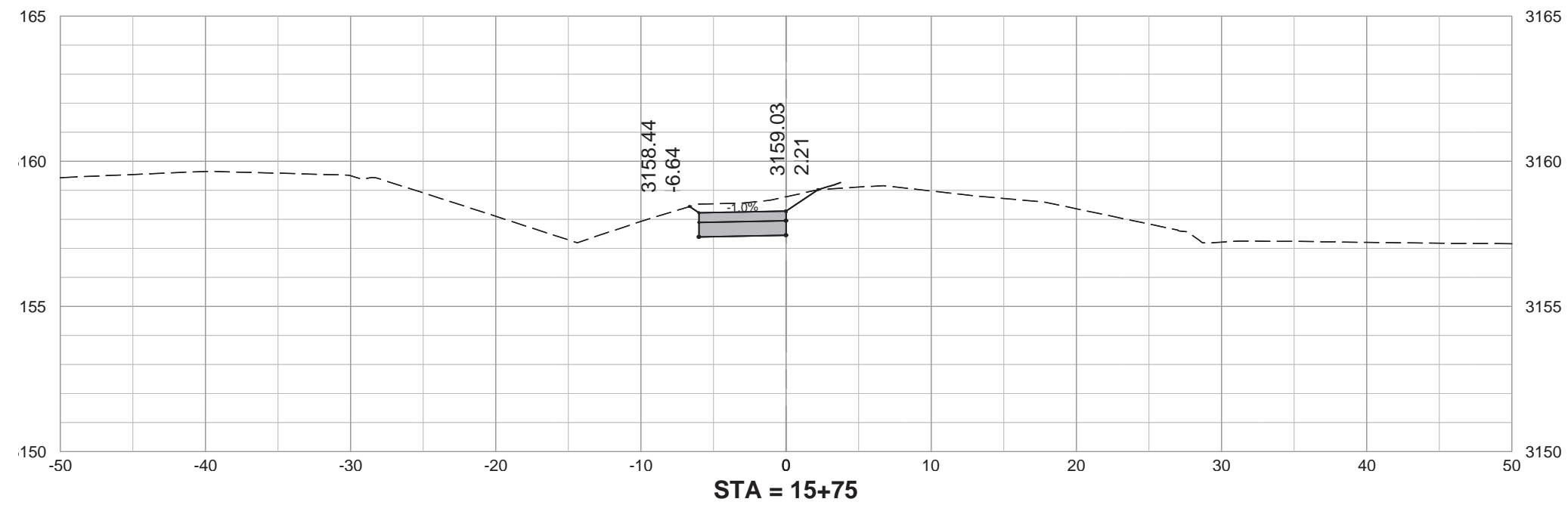
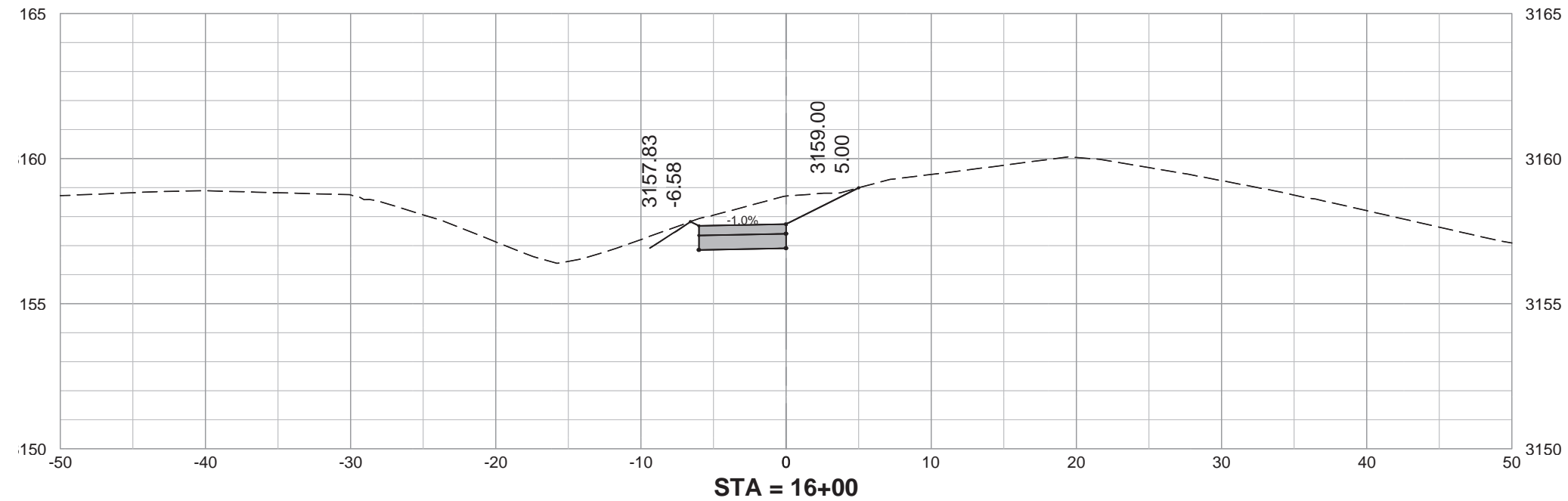

FOR BIDDING PURPOSES ONLY



PROJECT	SHEET	TOTAL SHEETS
P TAPU(47)	78	112

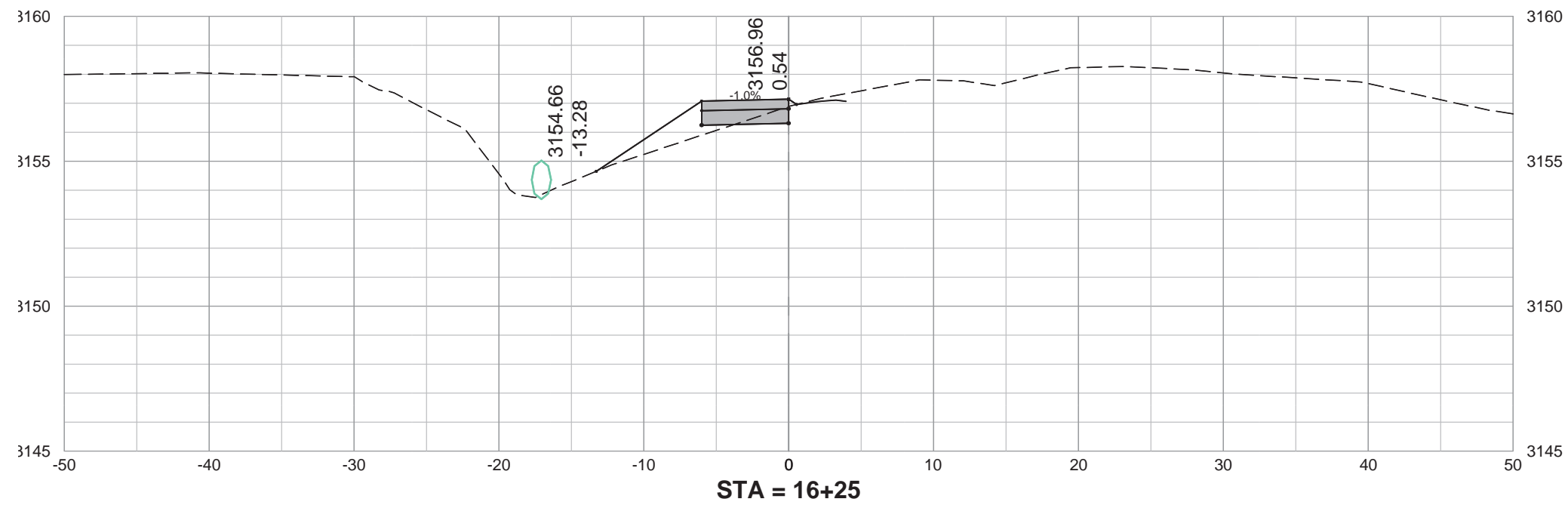
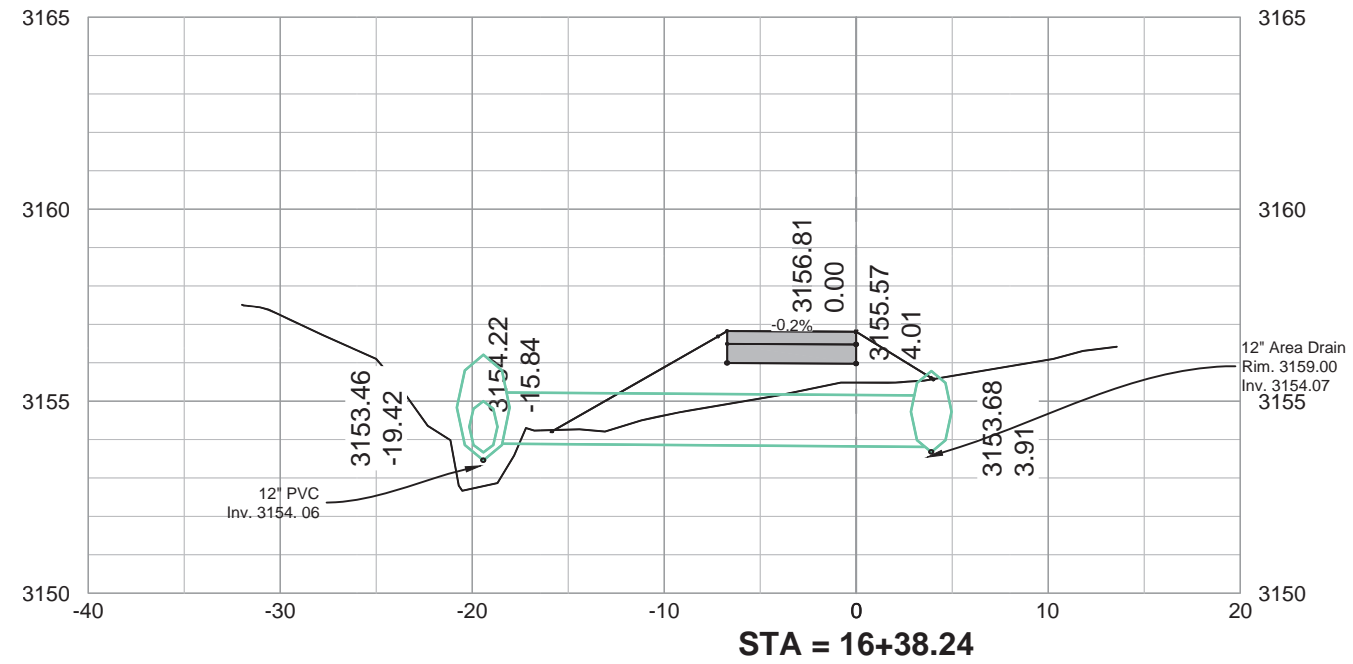

FOR BIDDING PURPOSES ONLY



PROJECT	SHEET	TOTAL SHEETS
P TAPU(47)	79	112

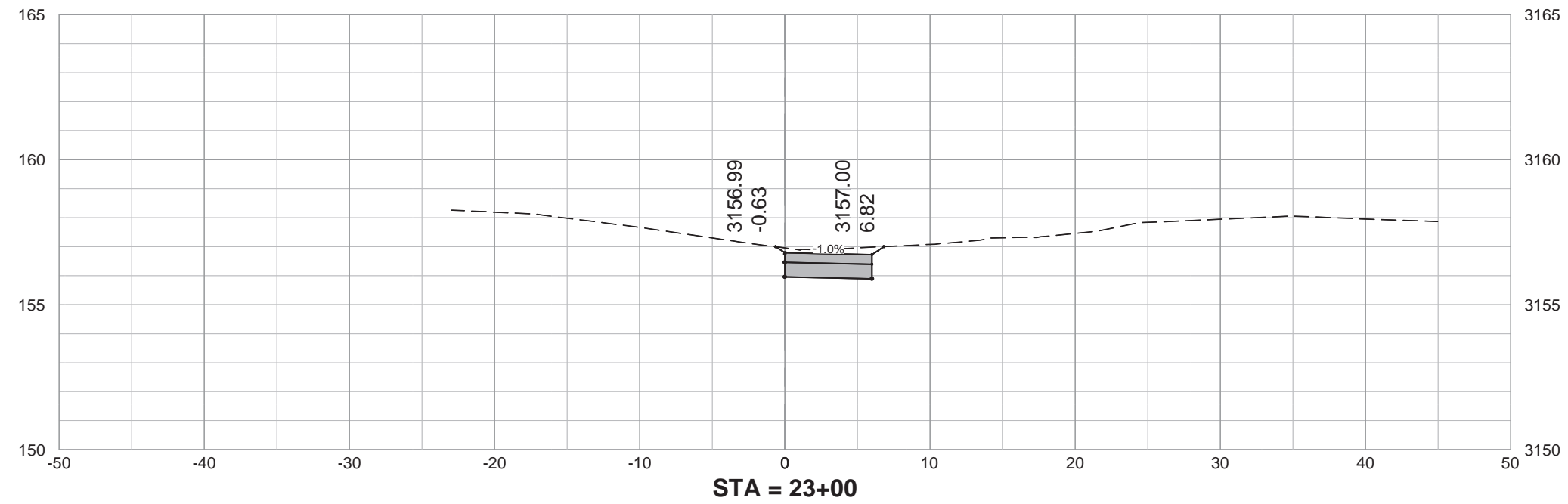
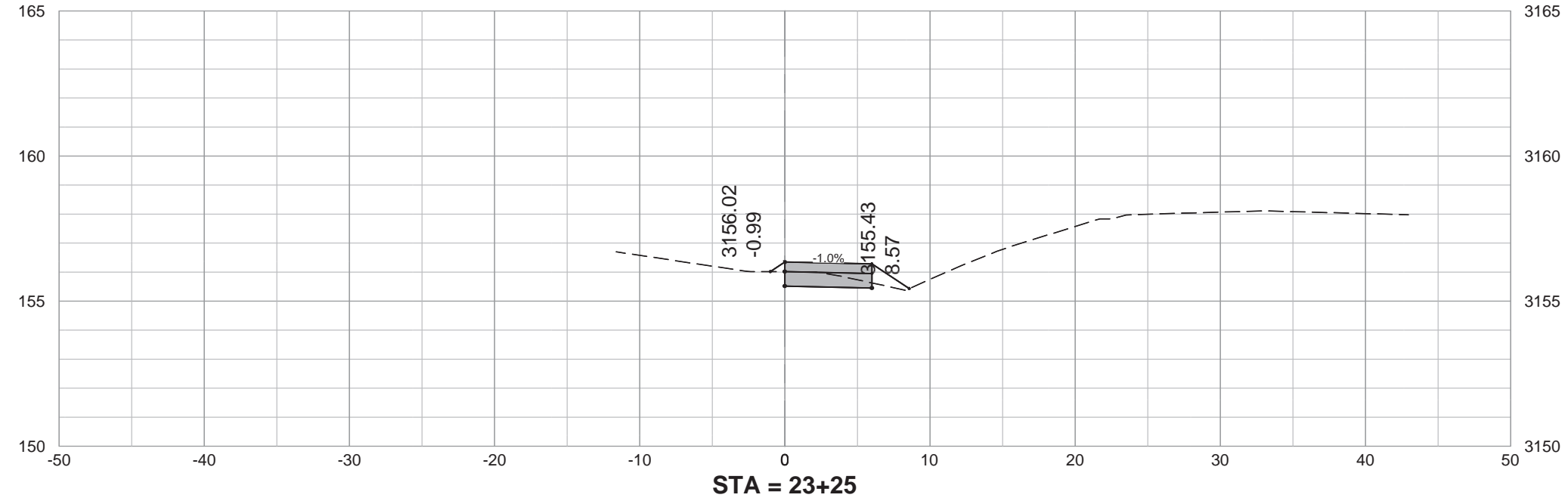

FOR BIDDING PURPOSES ONLY



PROJECT	SHEET	TOTAL SHEETS
P TAPU(47)	80	112

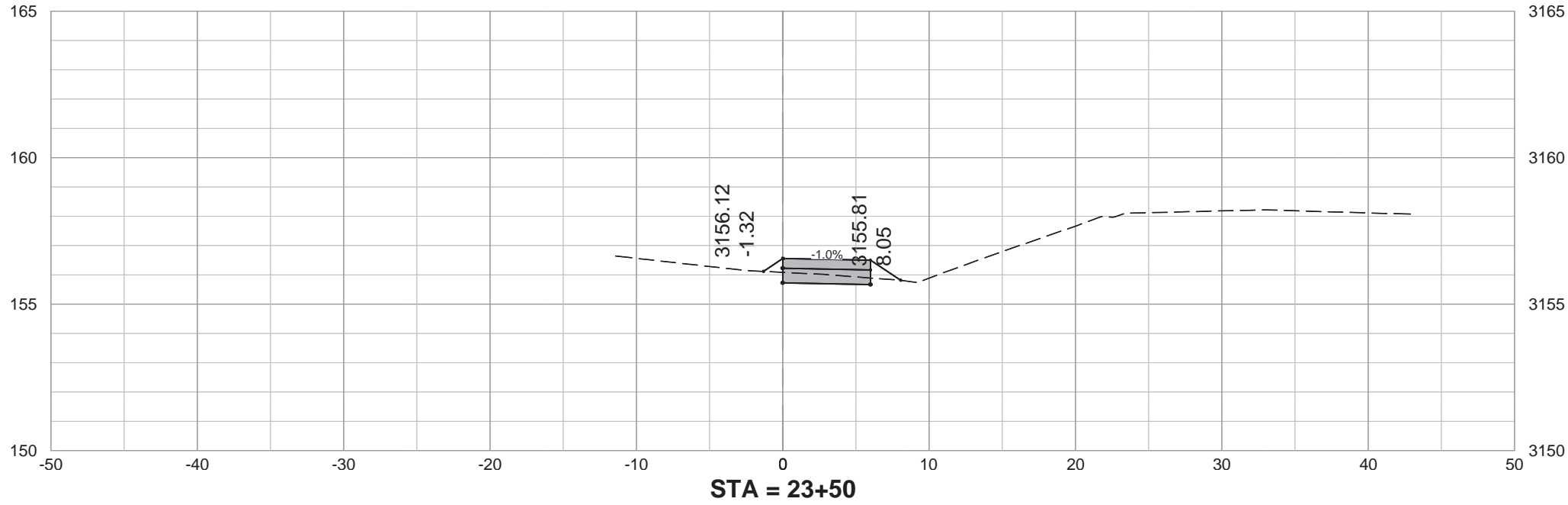
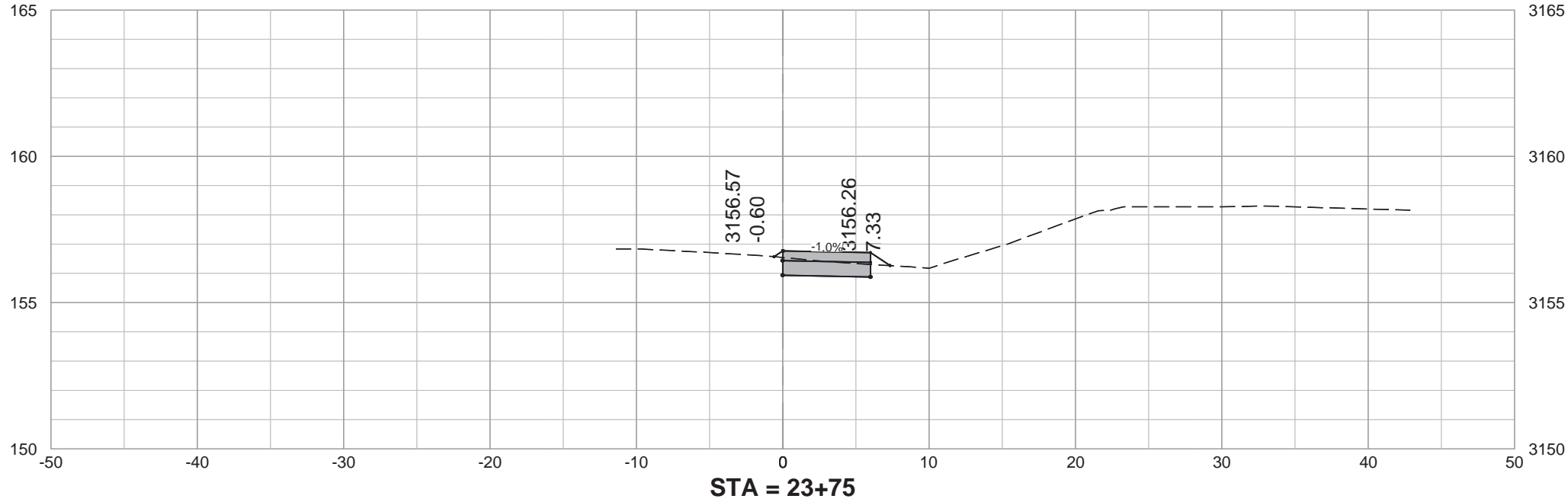

FOR BIDDING PURPOSES ONLY



PROJECT	SHEET	TOTAL SHEETS
P TAPU(47)	81	112

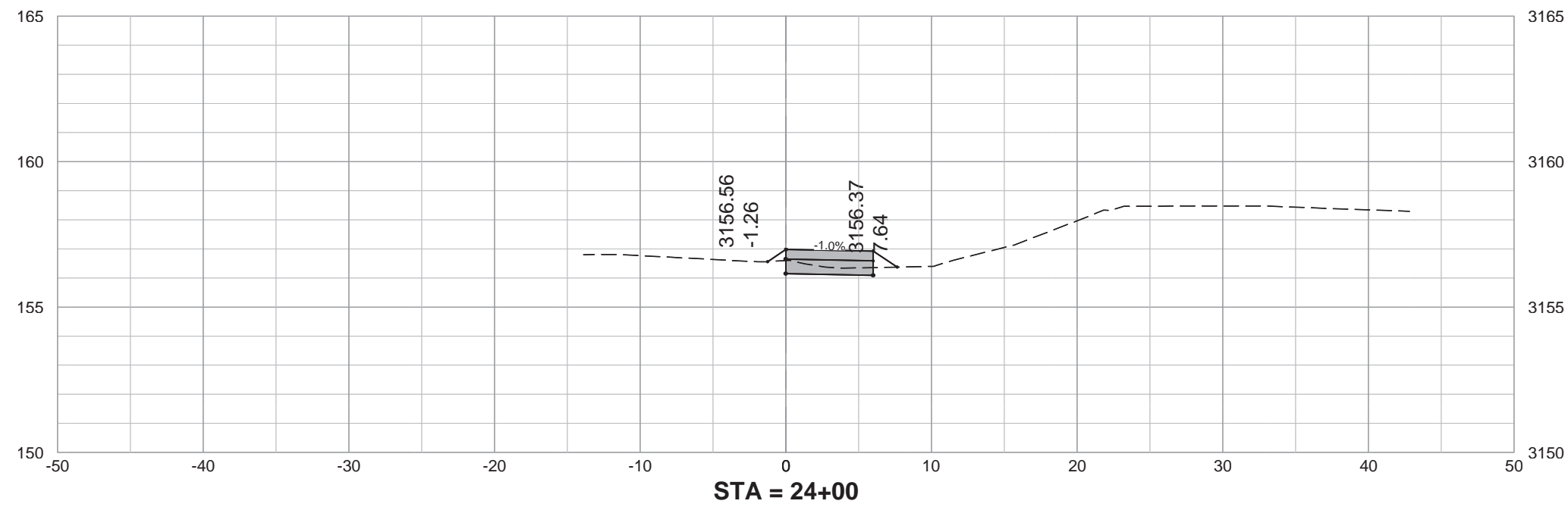
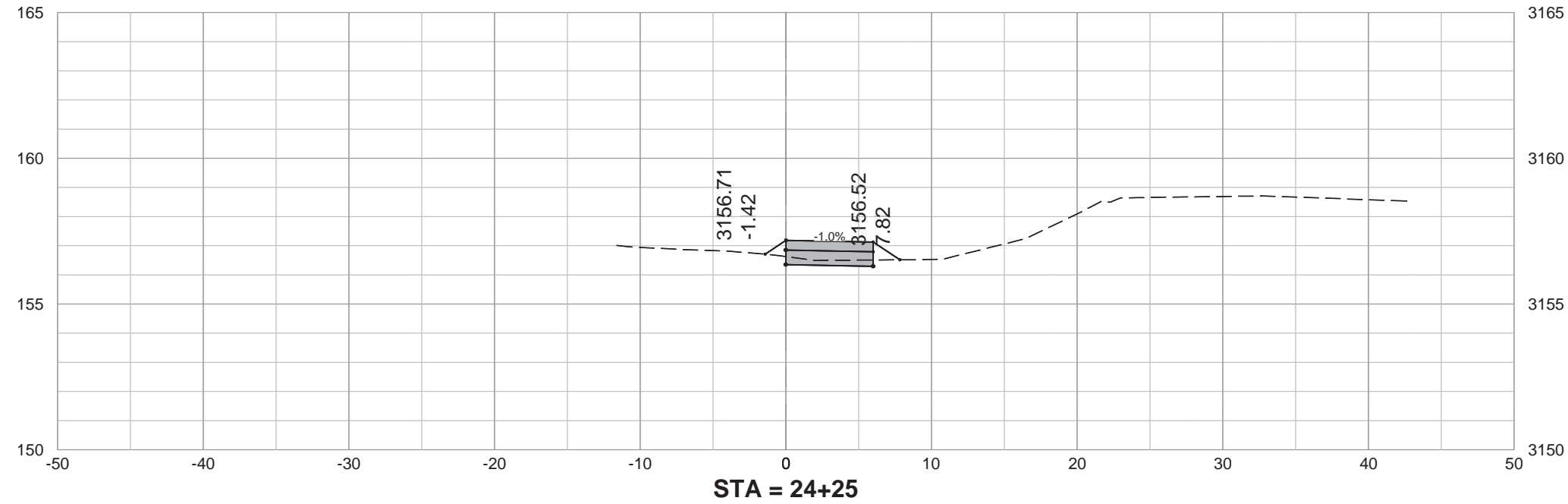

FOR BIDDING PURPOSES ONLY



PROJECT	SHEET	TOTAL SHEETS
P TAPU(47)	82	112

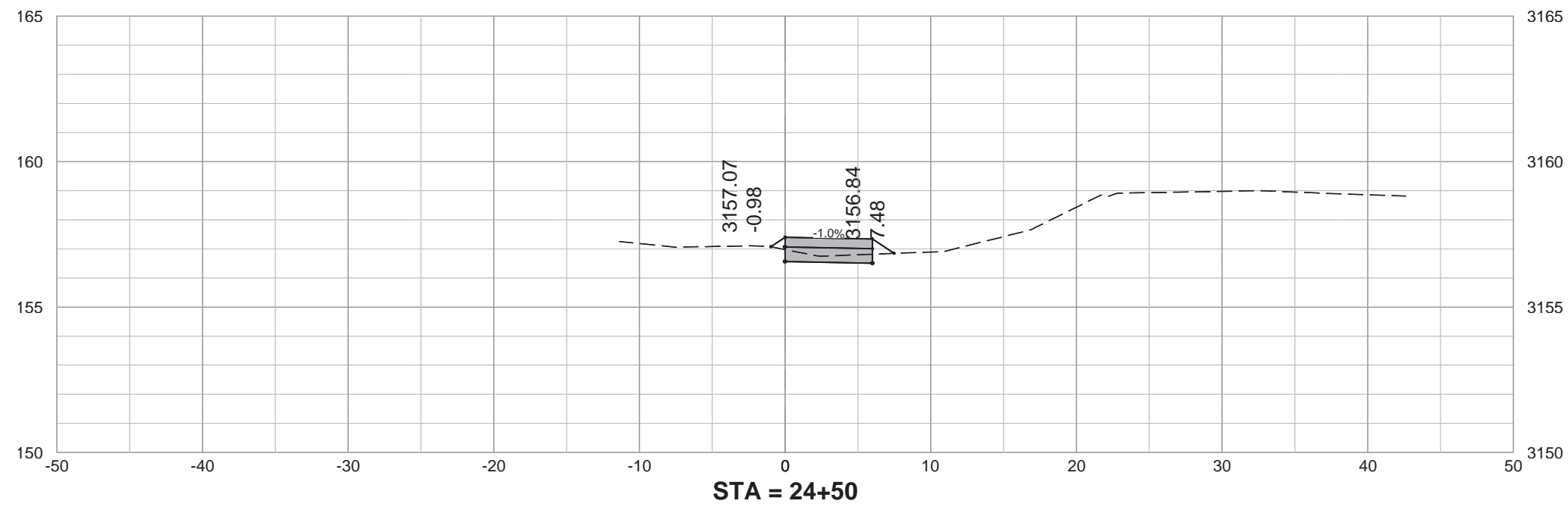
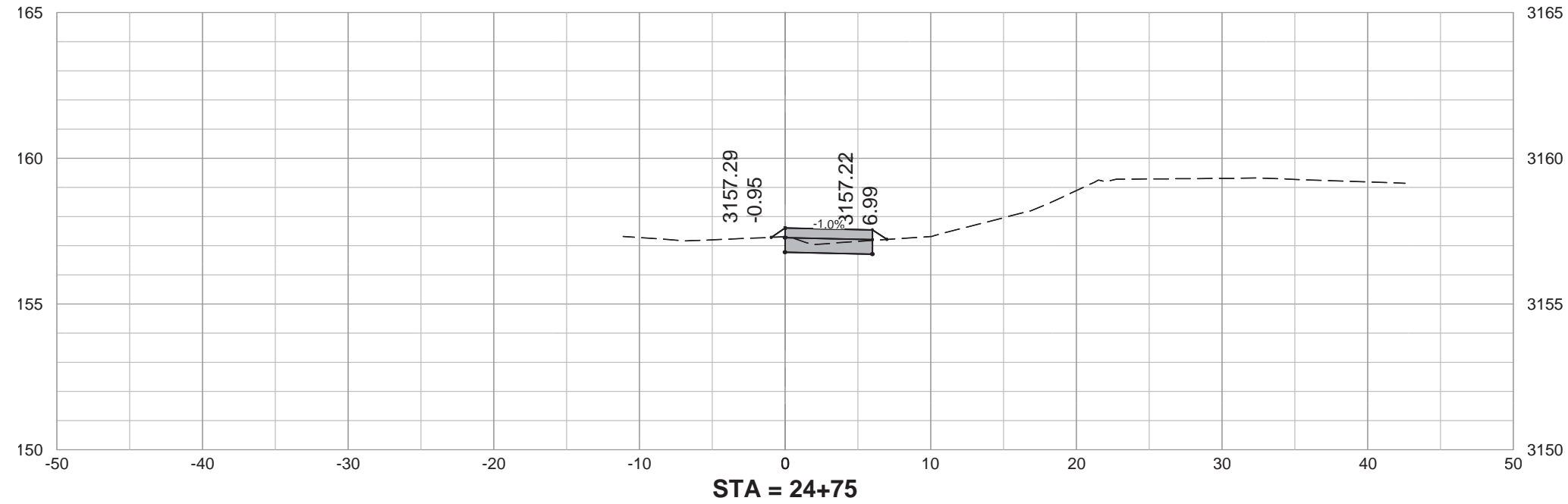

FOR BIDDING PURPOSES ONLY



PROJECT	SHEET	TOTAL SHEETS
P TAPU(47)	83	112

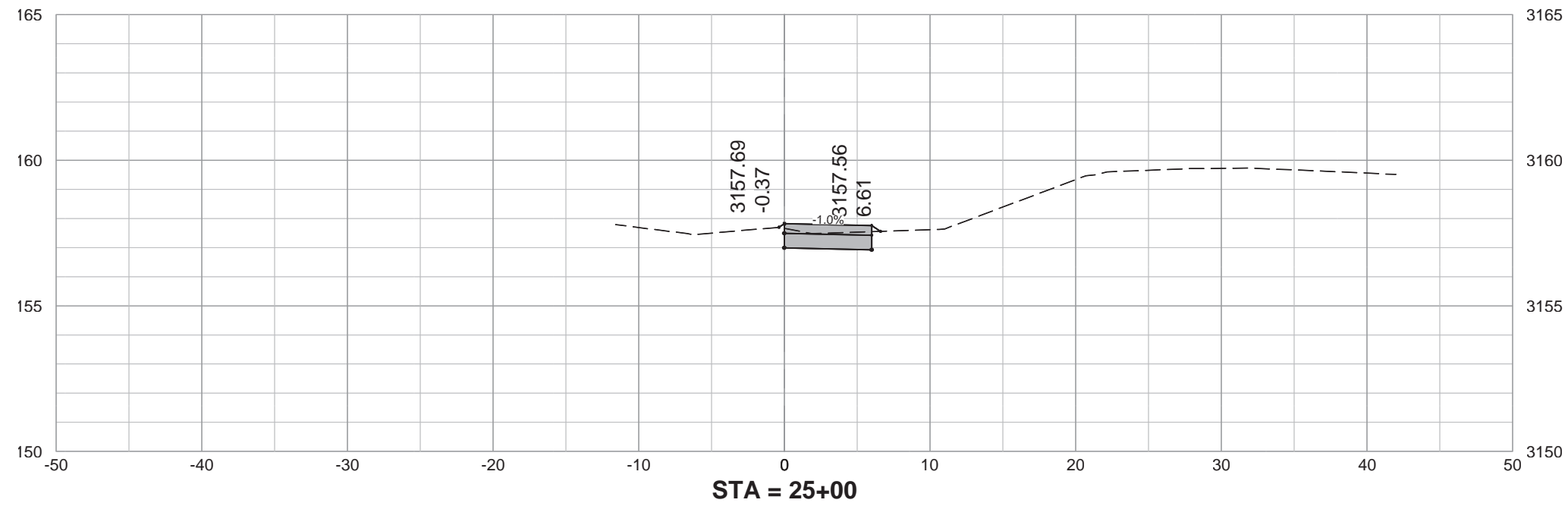
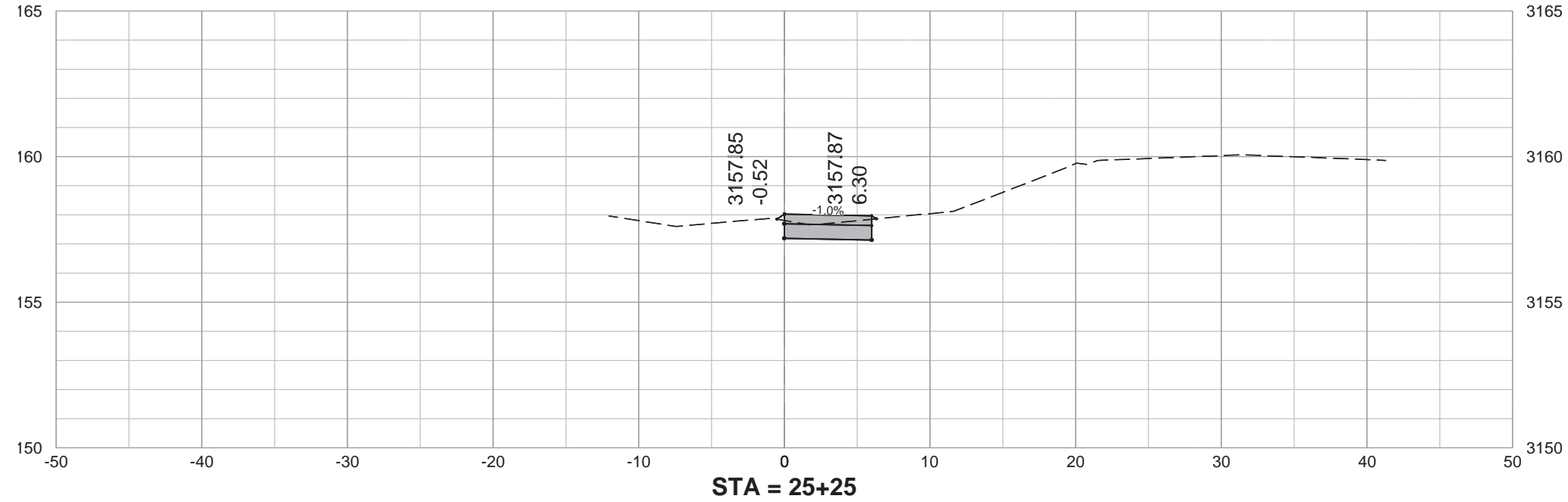

FOR BIDDING PURPOSES ONLY



PROJECT	SHEET	TOTAL SHEETS
P TAPU(47)	84	112

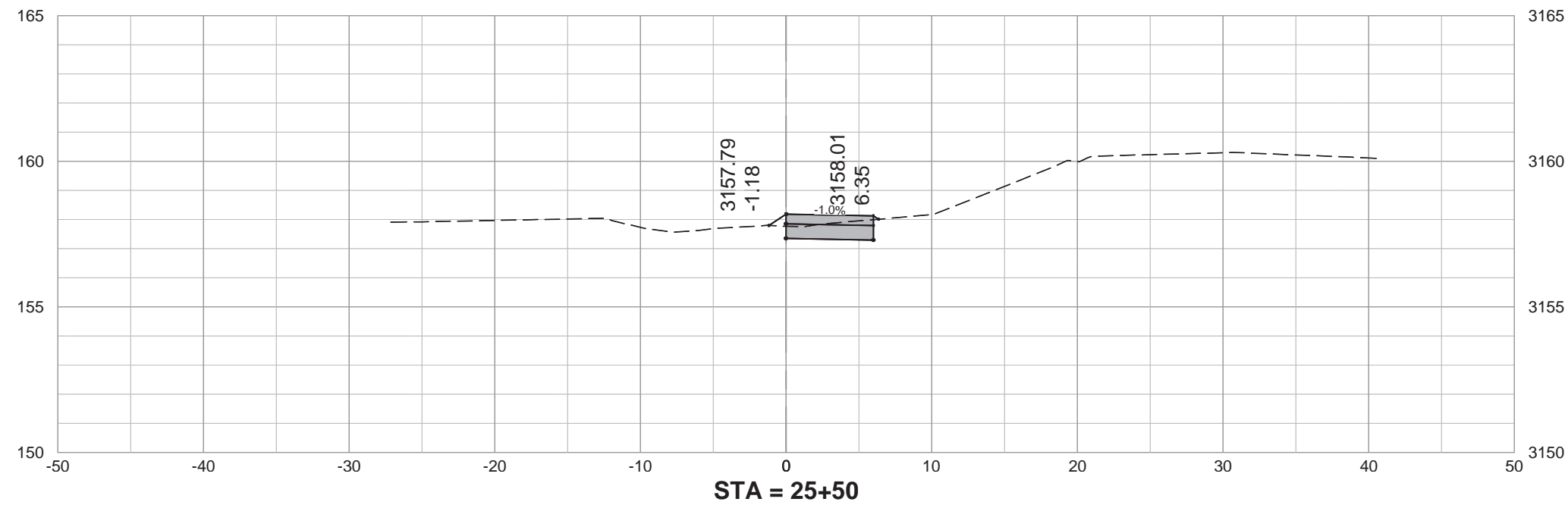
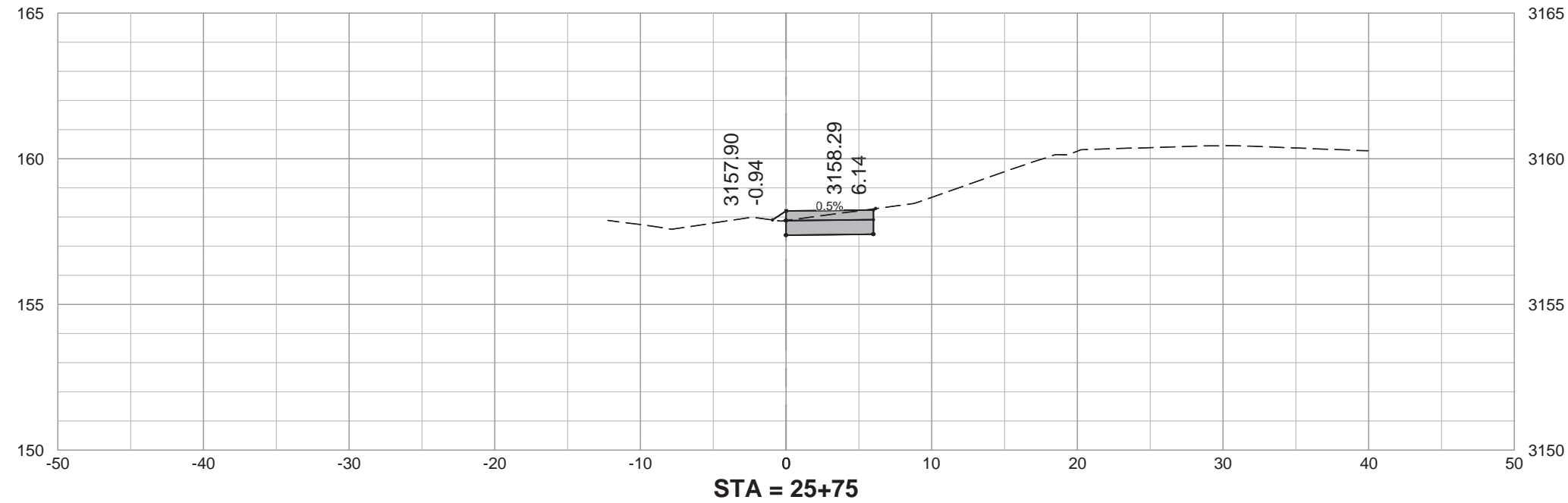

FOR BIDDING PURPOSES ONLY



PROJECT	SHEET	TOTAL SHEETS
P TAPU(47)	85	112

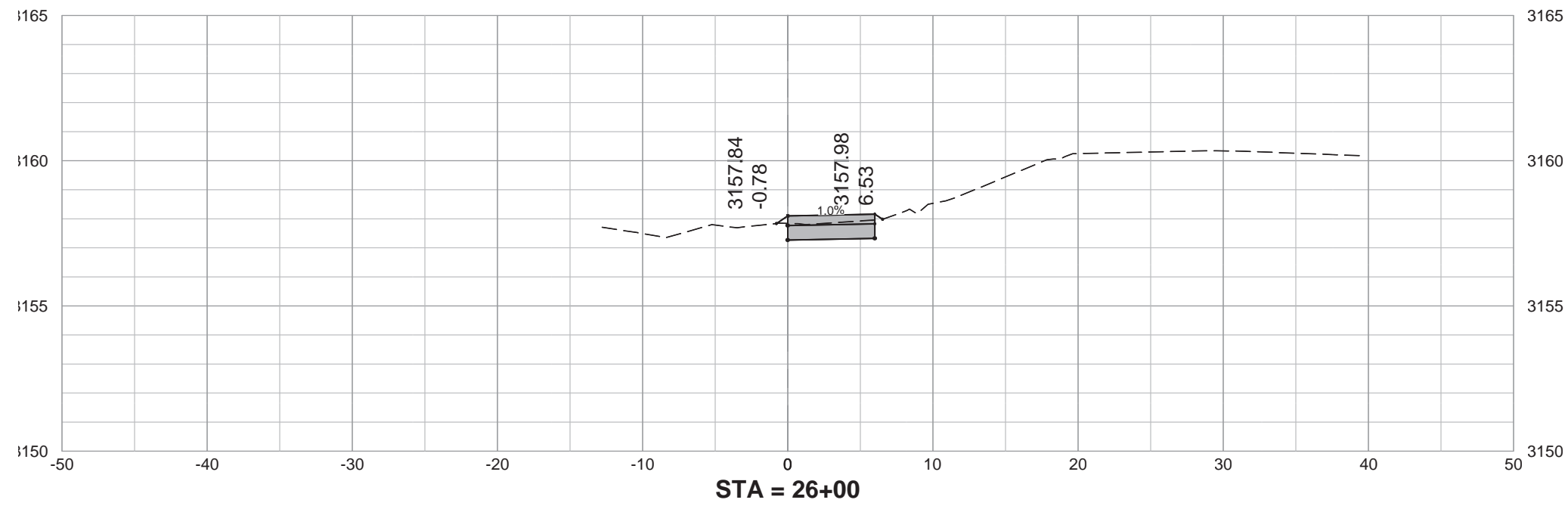
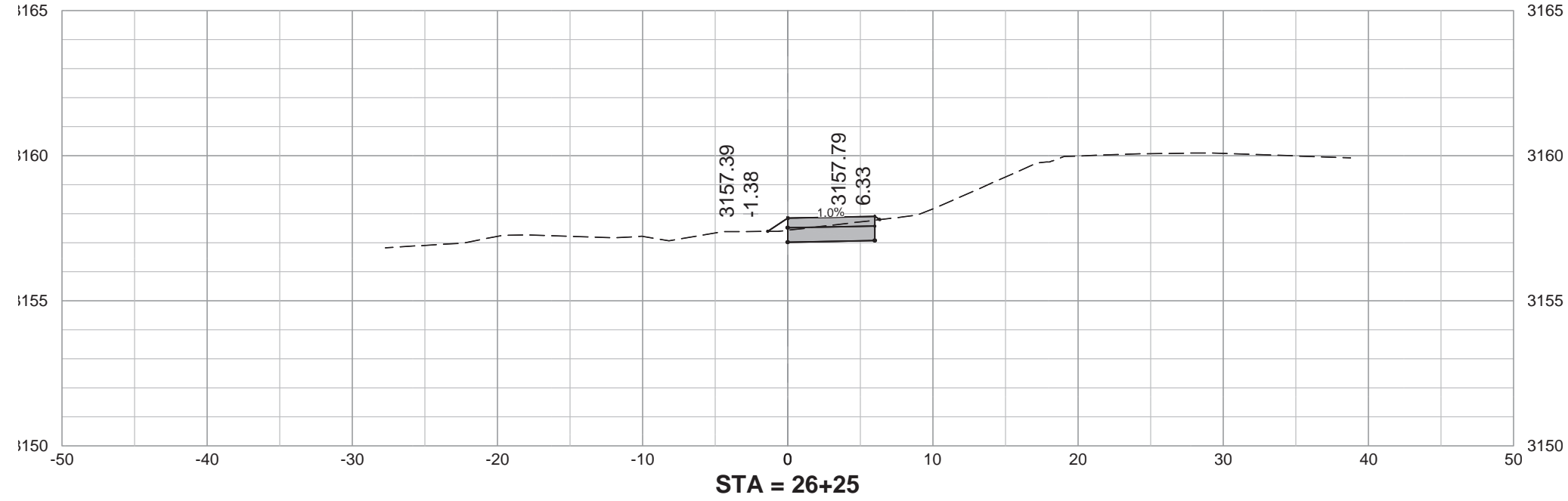

FOR BIDDING PURPOSES ONLY



PROJECT	SHEET	TOTAL SHEETS
P TAPU(47)	86	112

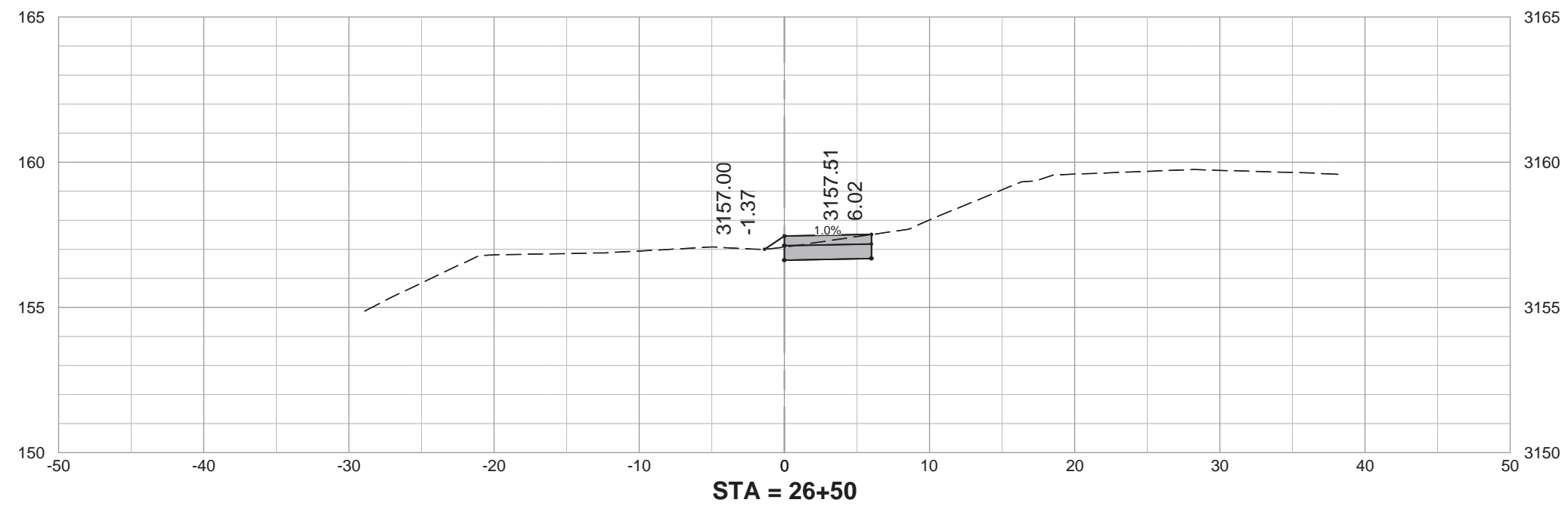
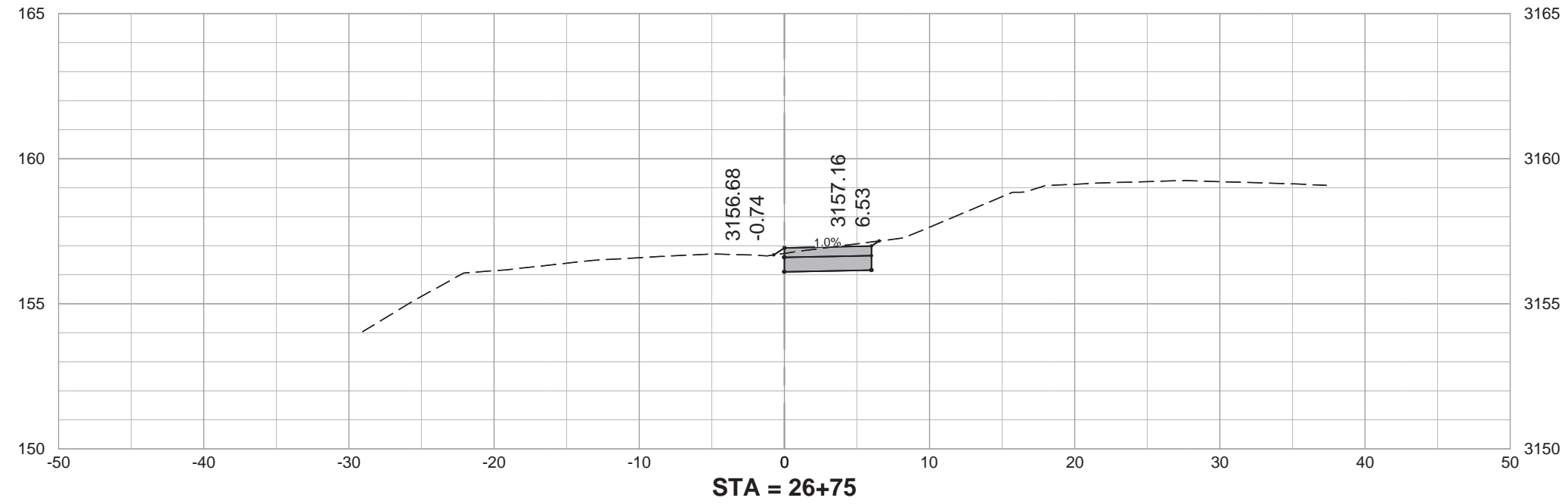

FOR BIDDING PURPOSES ONLY



PROJECT	SHEET	TOTAL SHEETS
P TAPU(47)	87	112

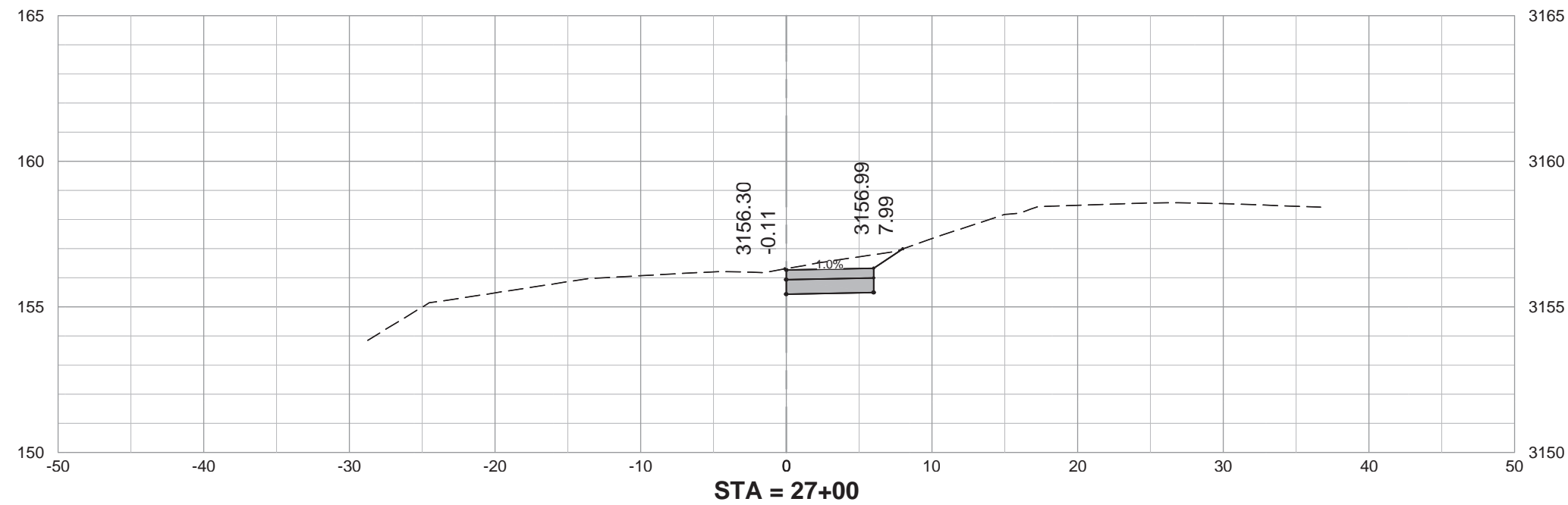
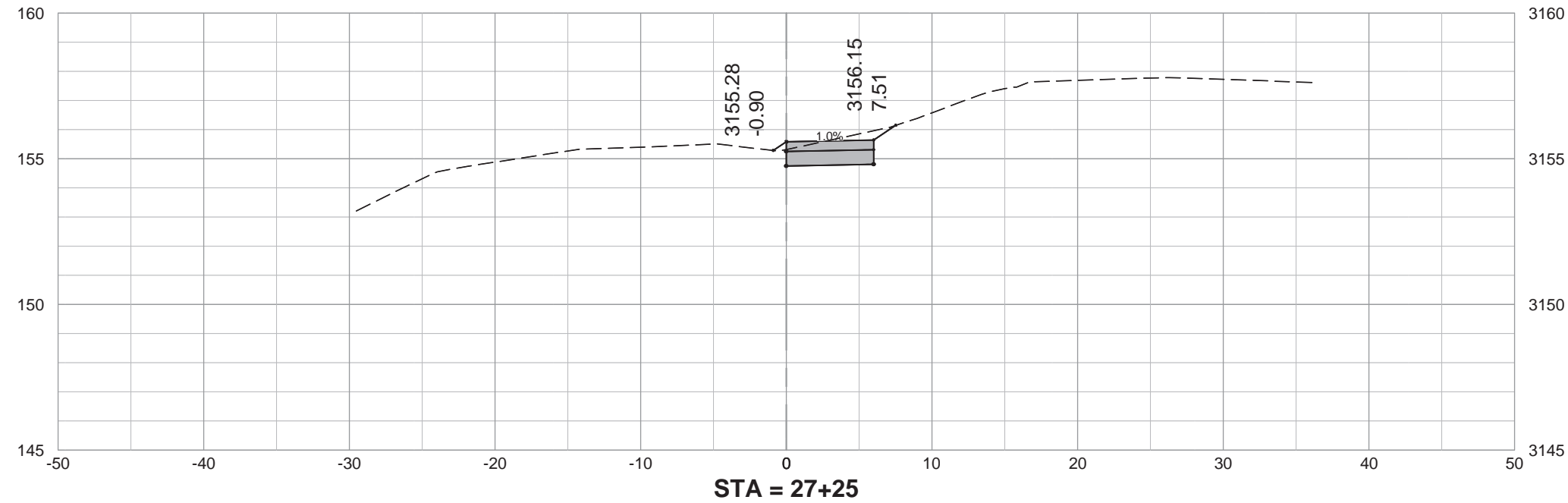

FOR BIDDING PURPOSES ONLY



PROJECT	SHEET	TOTAL SHEETS
P TAPU(47)	88	112

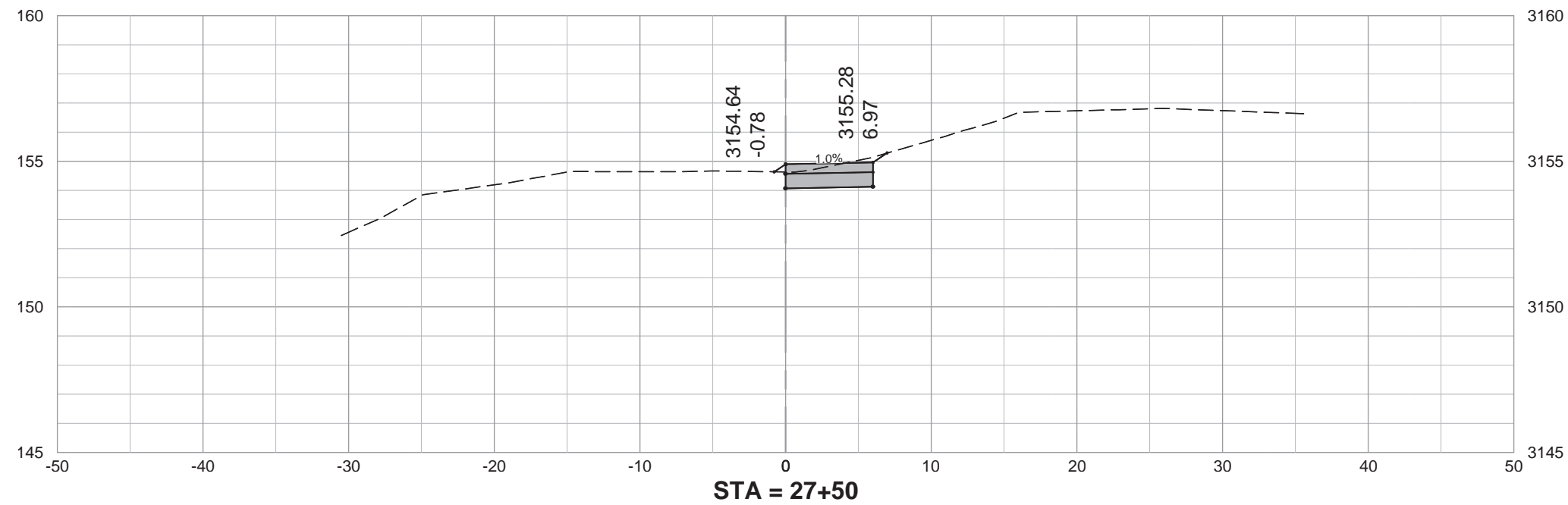
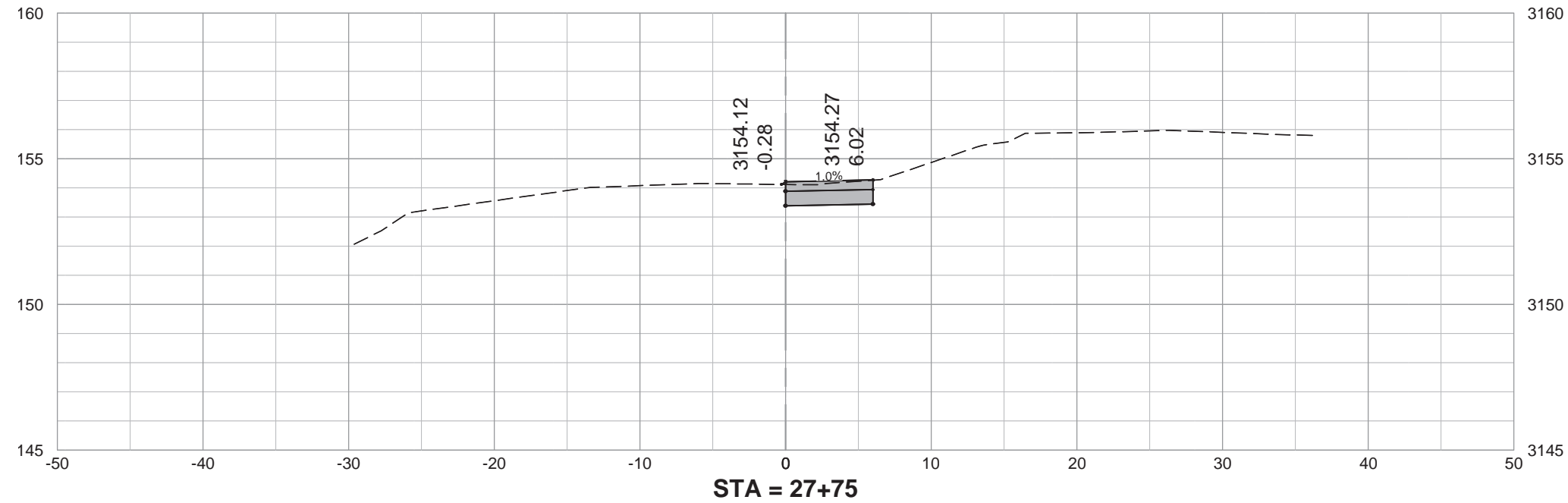

FOR BIDDING PURPOSES ONLY



PROJECT	SHEET	TOTAL SHEETS
P TAPU(47)	89	112

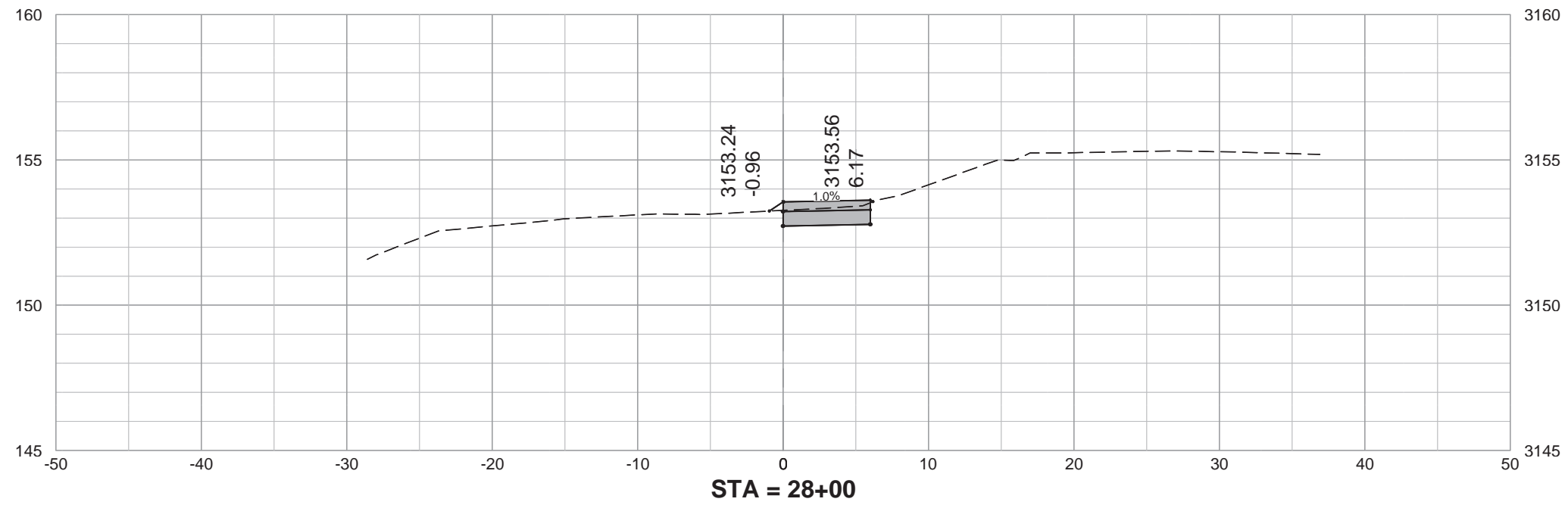
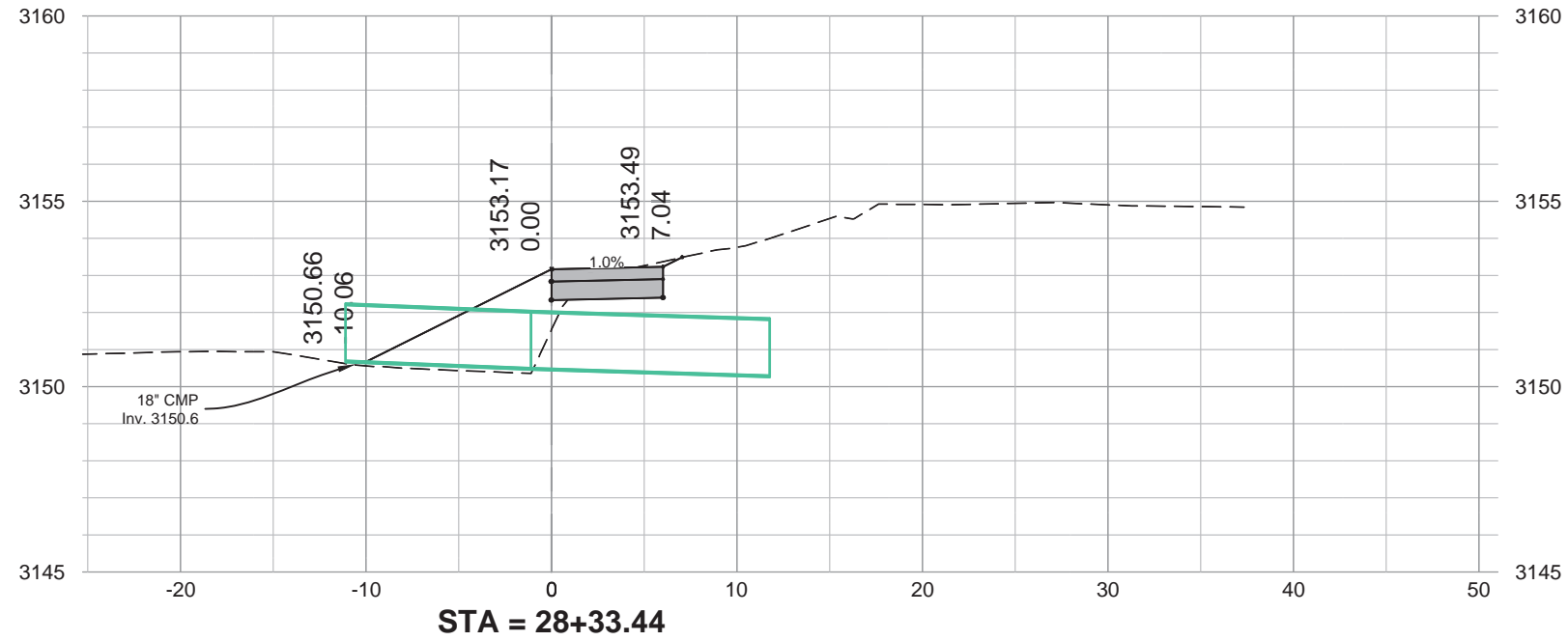

FOR BIDDING PURPOSES ONLY



PROJECT	SHEET	TOTAL SHEETS
P TAPU(47)	90	112

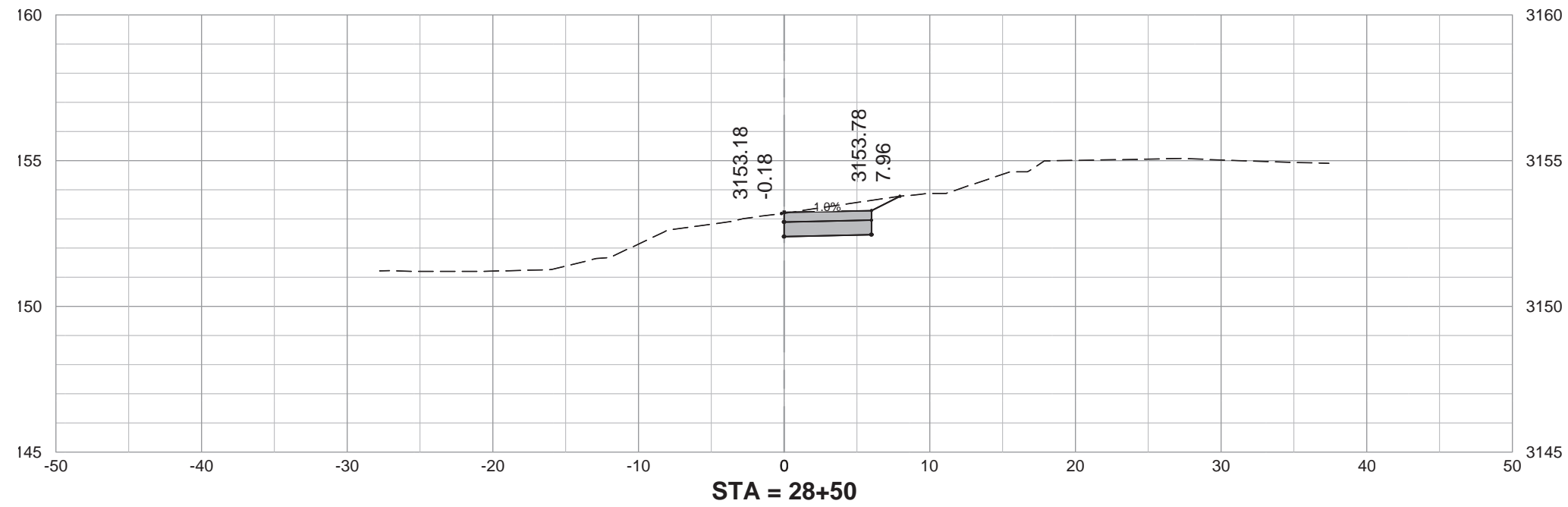
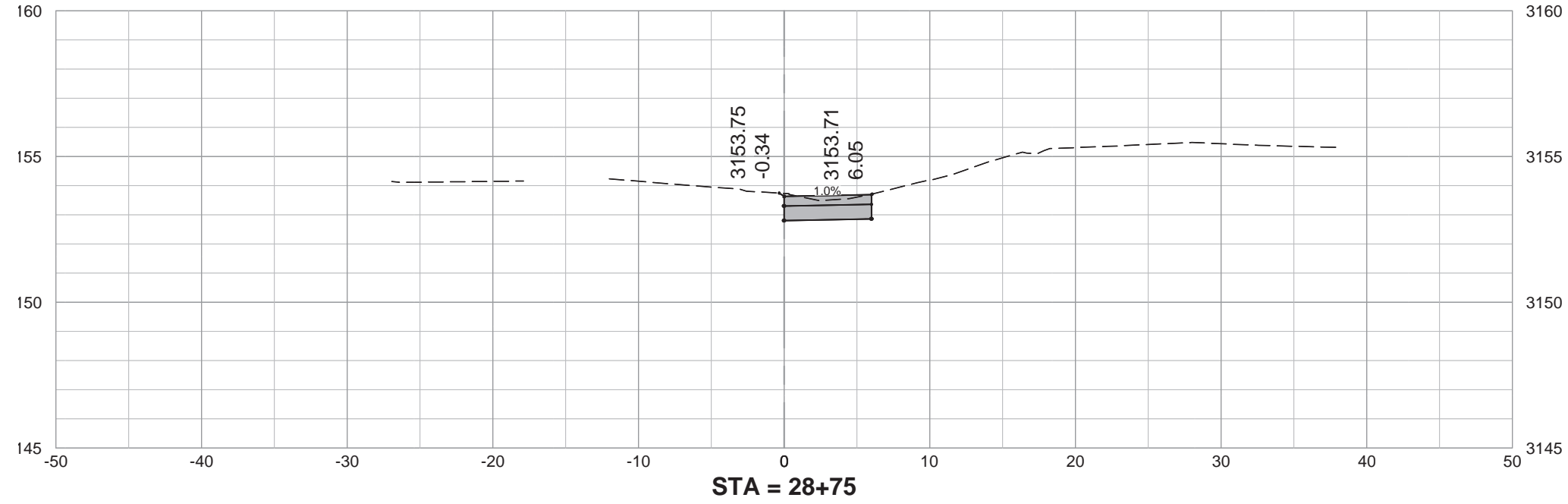

FOR BIDDING PURPOSES ONLY



PROJECT	SHEET	TOTAL SHEETS
P TAPU(47)	91	112

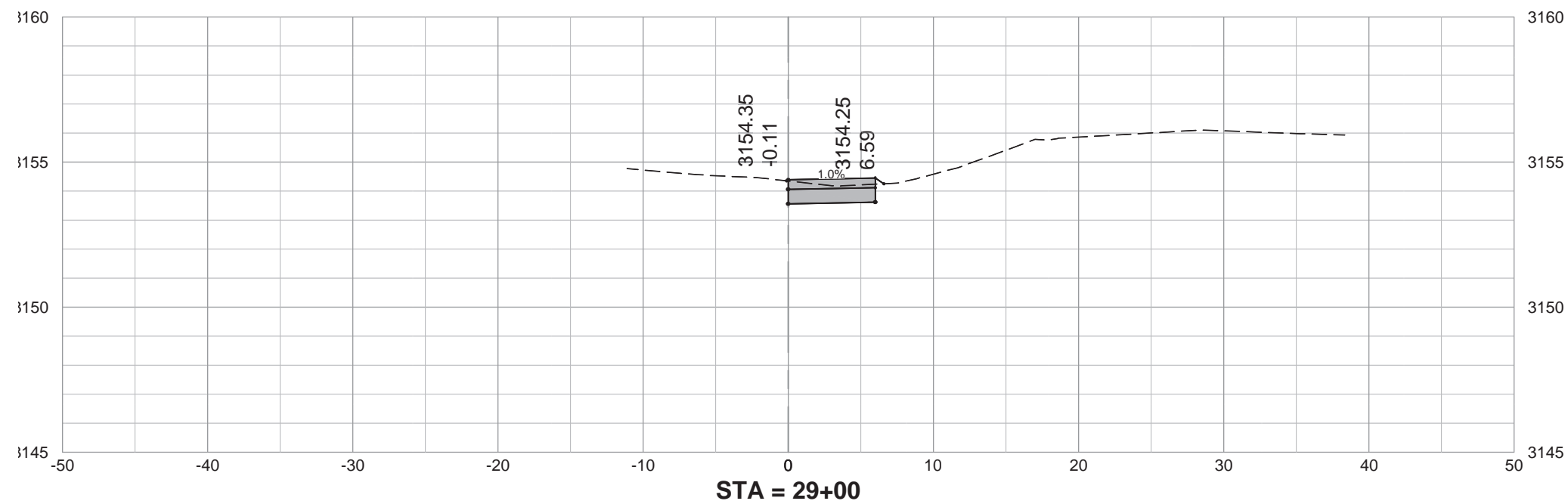
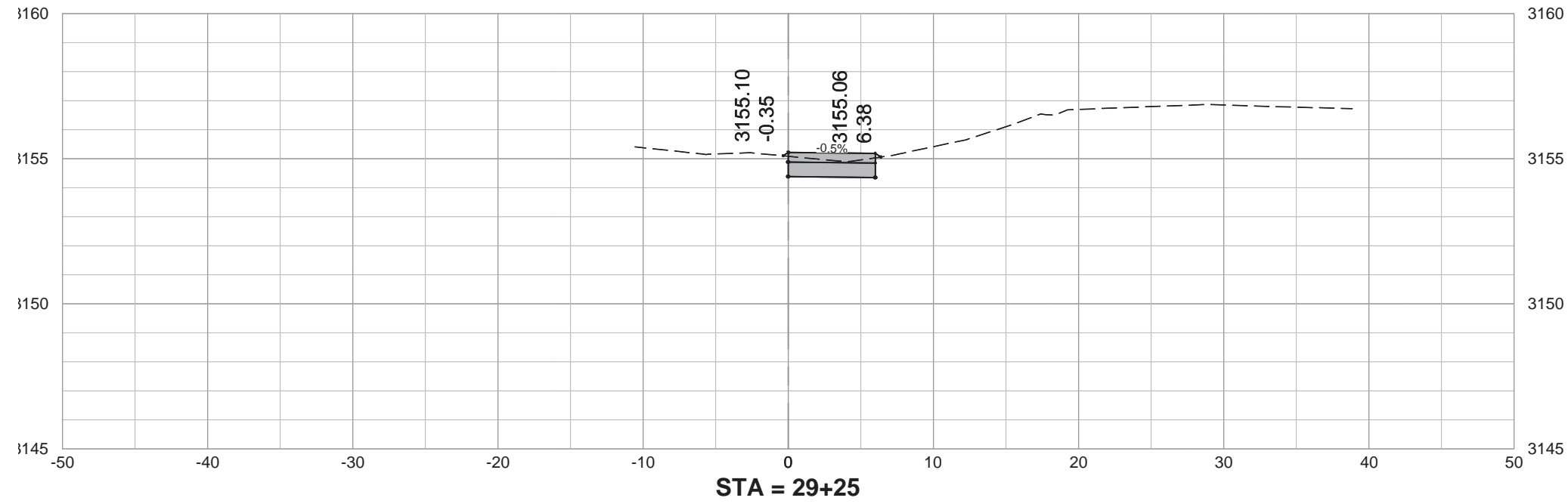

FOR BIDDING PURPOSES ONLY



PROJECT	SHEET	TOTAL SHEETS
P TAPU(47)	92	112

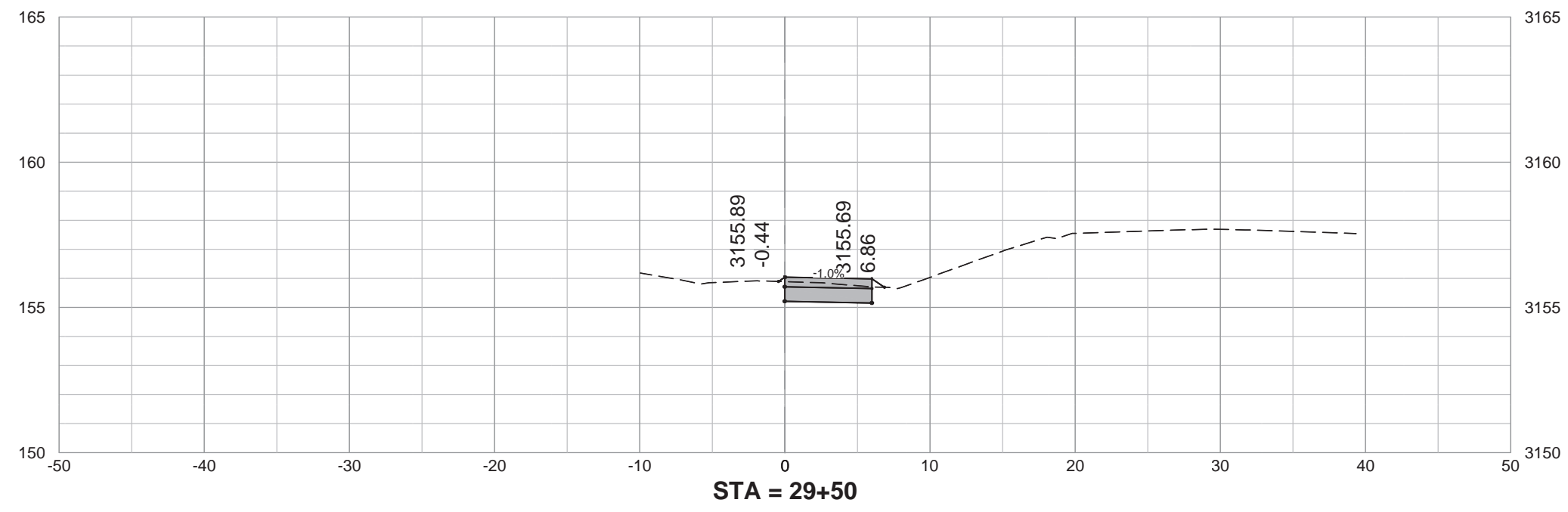
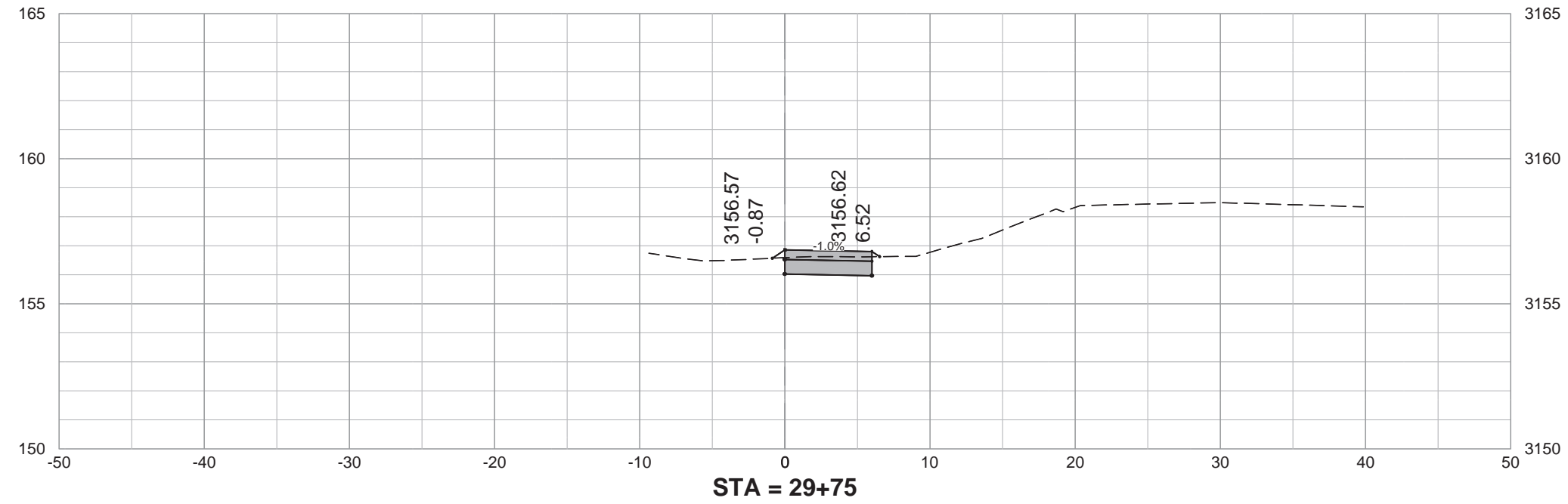

FOR BIDDING PURPOSES ONLY



PROJECT	SHEET	TOTAL SHEETS
P TAPU(47)	93	112

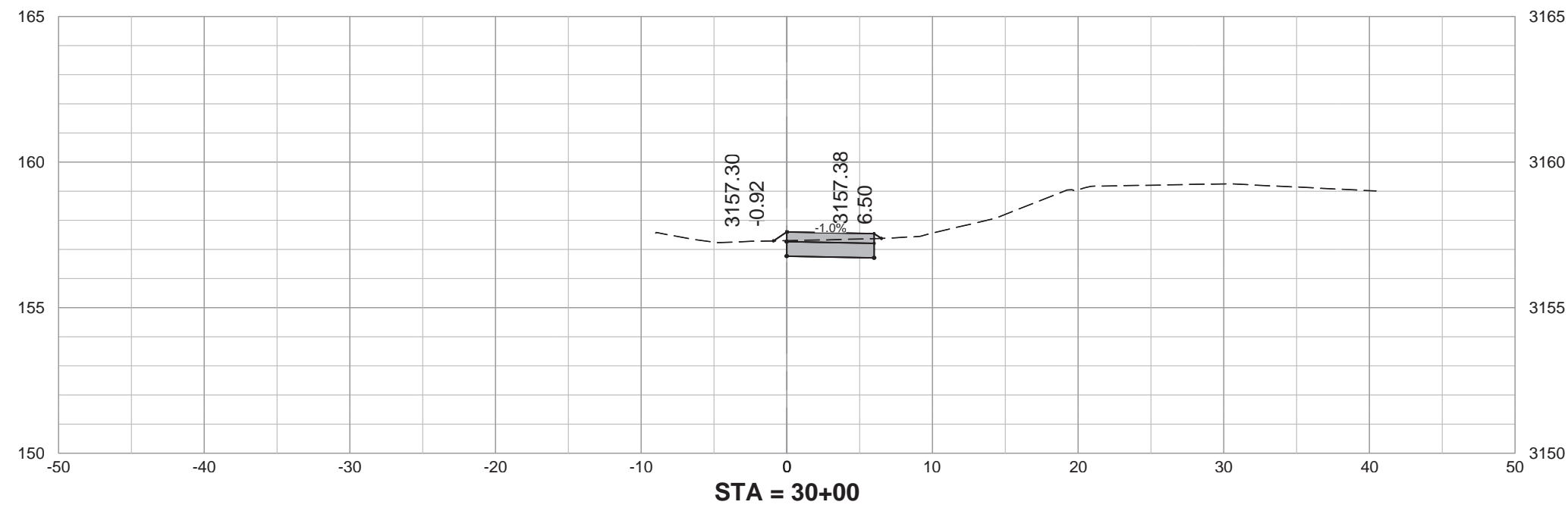
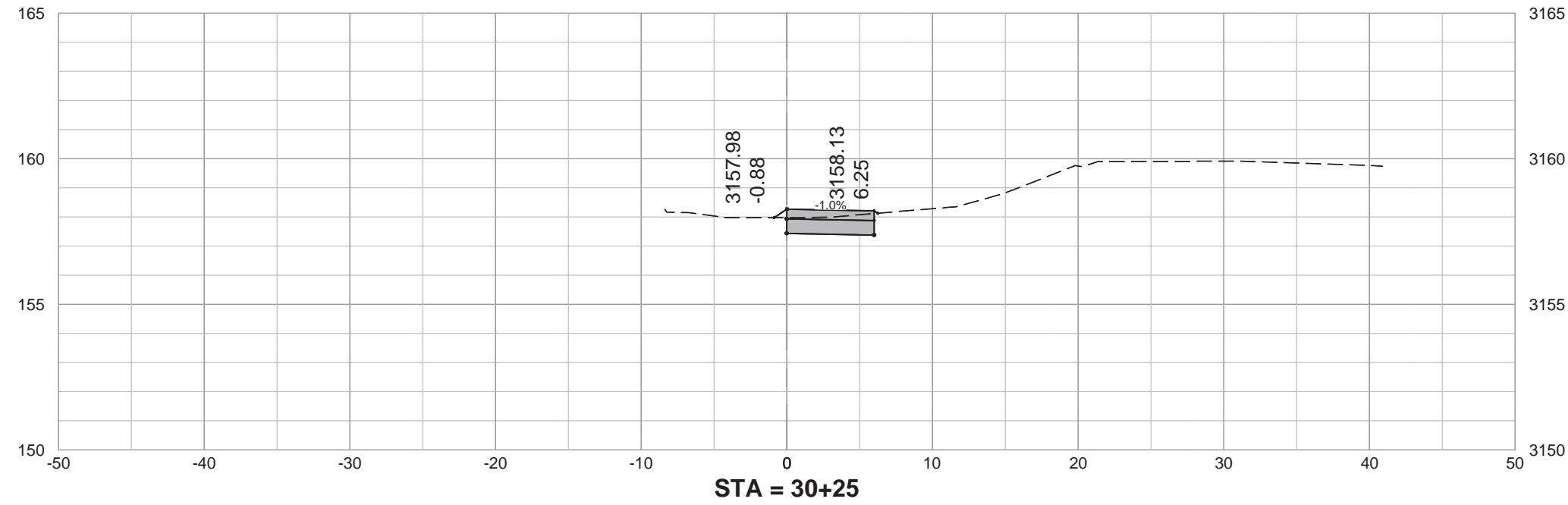

FOR BIDDING PURPOSES ONLY



PROJECT	SHEET	TOTAL SHEETS
P TAPU(47)	94	112

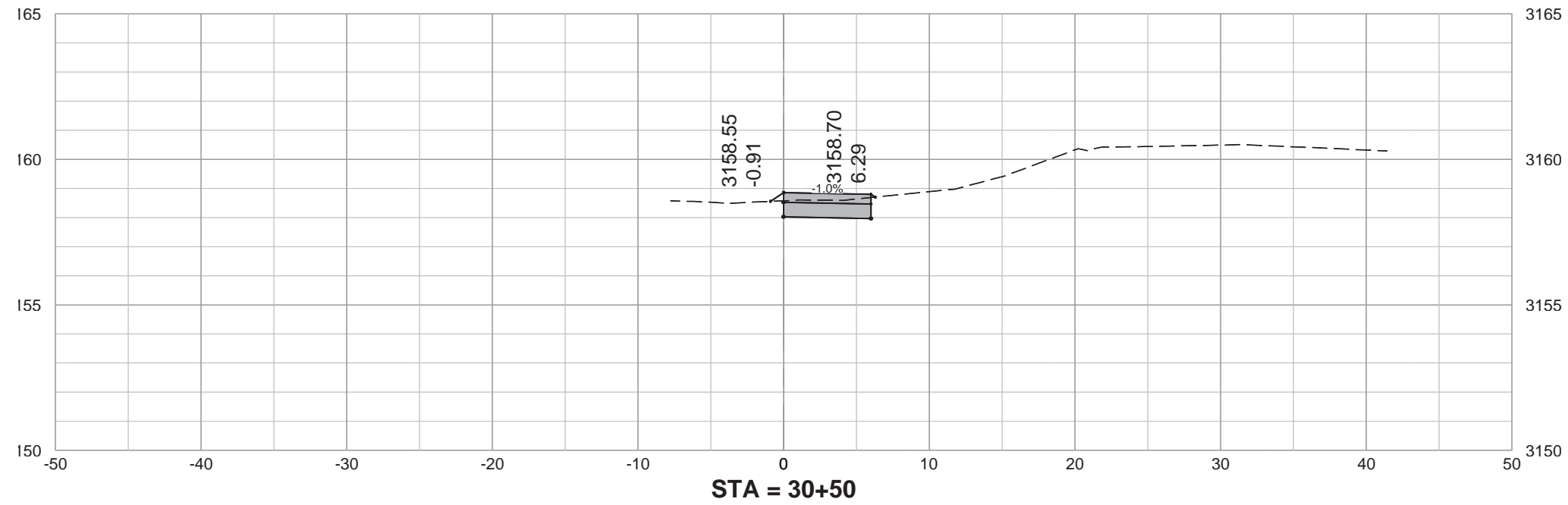
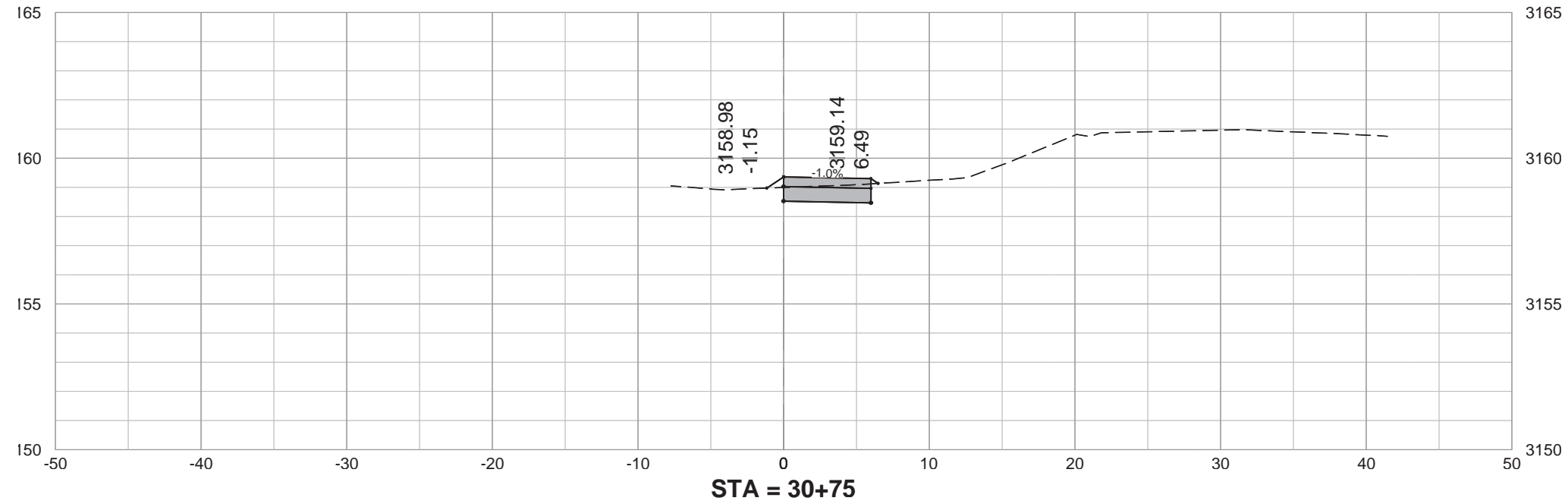

FOR BIDDING PURPOSES ONLY



PROJECT	SHEET	TOTAL SHEETS
P TAPU(47)	95	112

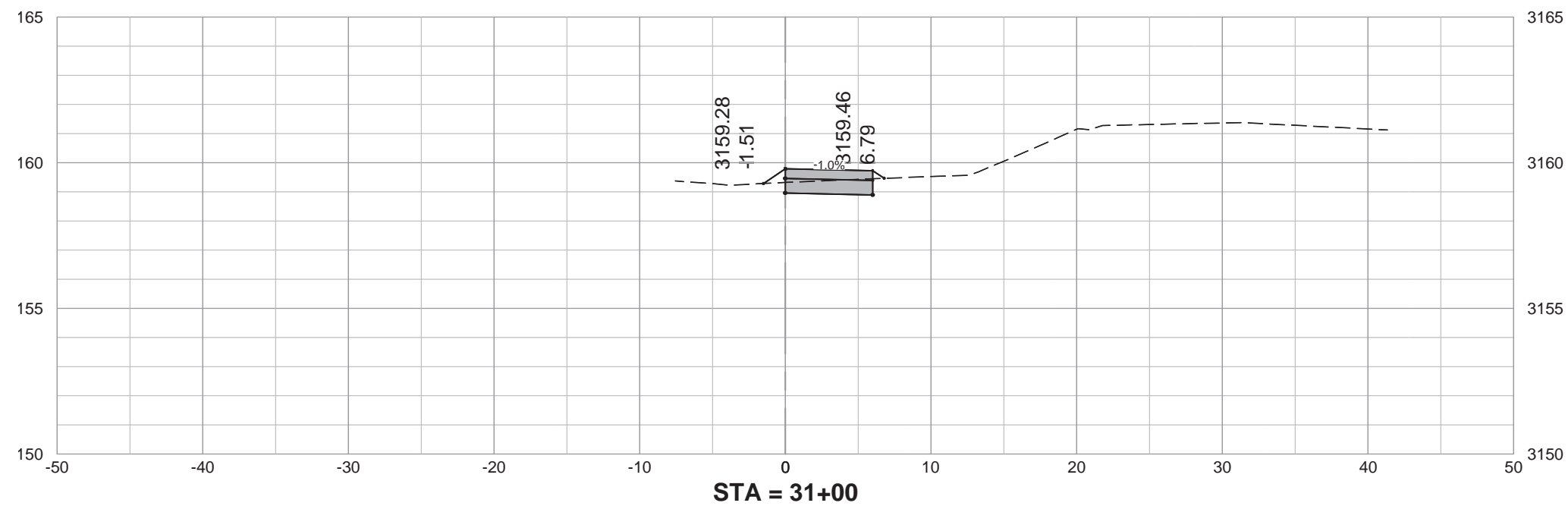
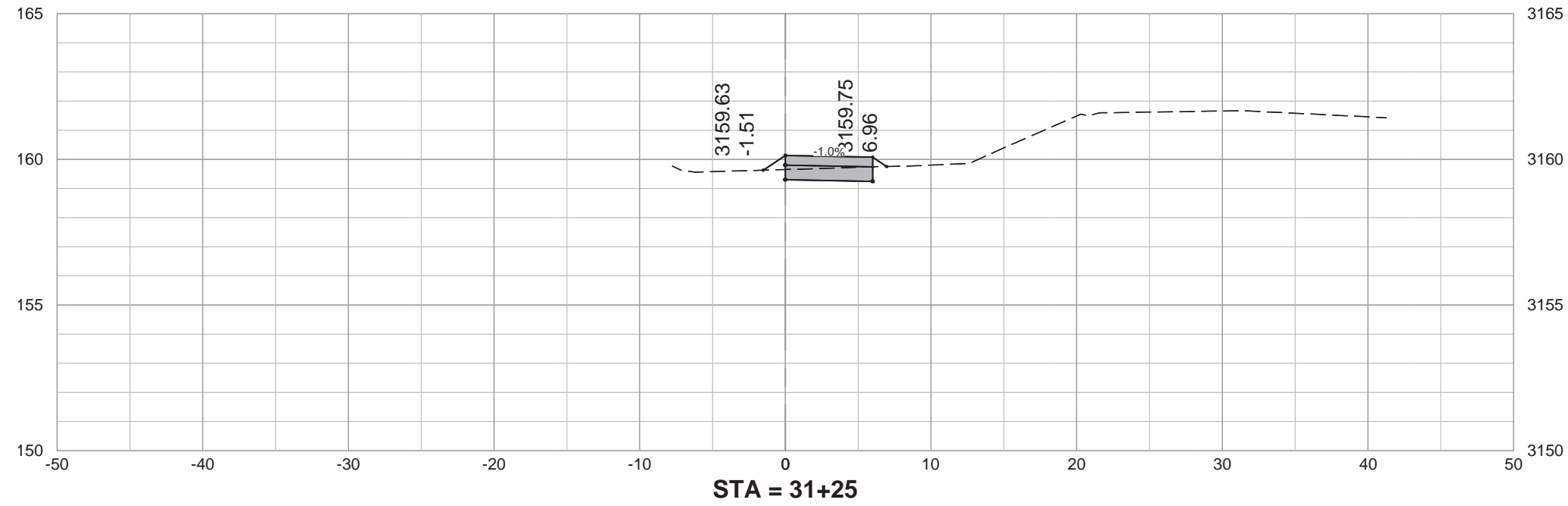

FOR BIDDING PURPOSES ONLY



PROJECT	SHEET	TOTAL SHEETS
P TAPU(47)	96	112

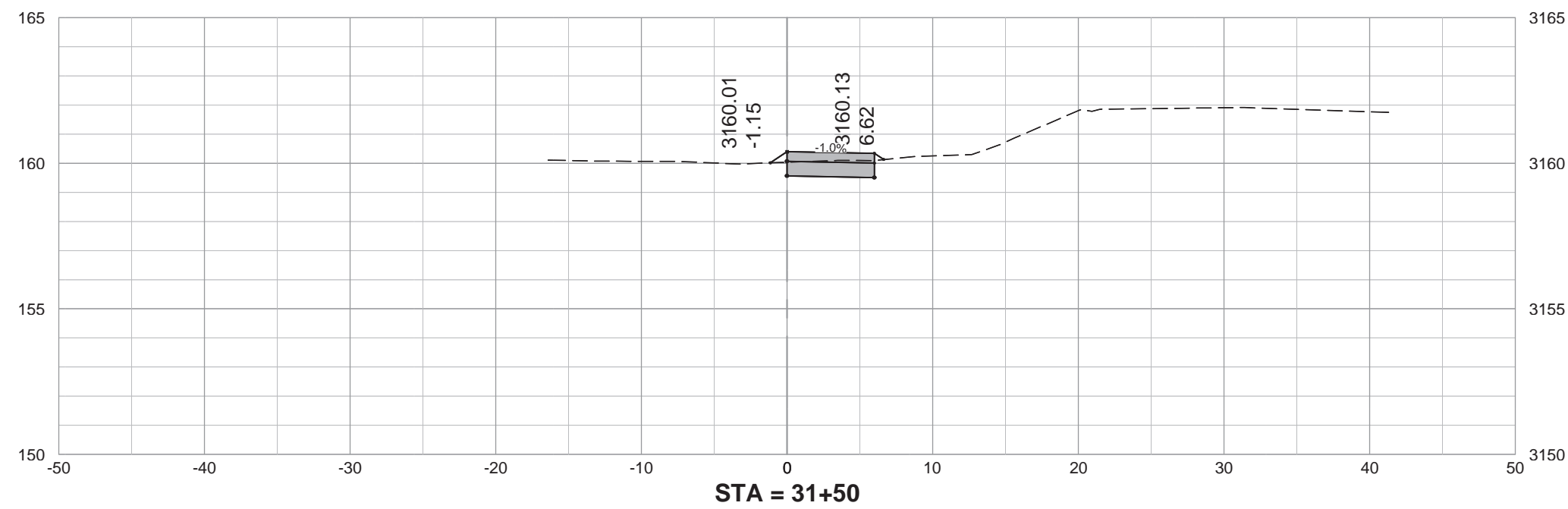
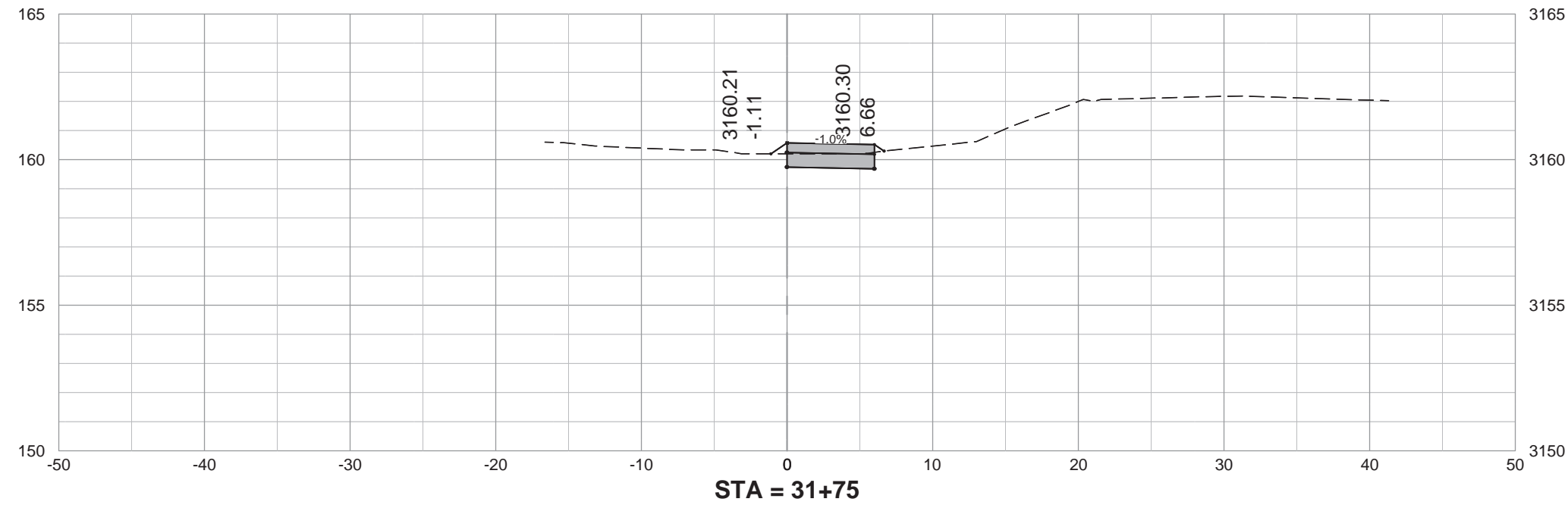

FOR BIDDING PURPOSES ONLY



PROJECT	SHEET	TOTAL SHEETS
P TAPU(47)	97	112

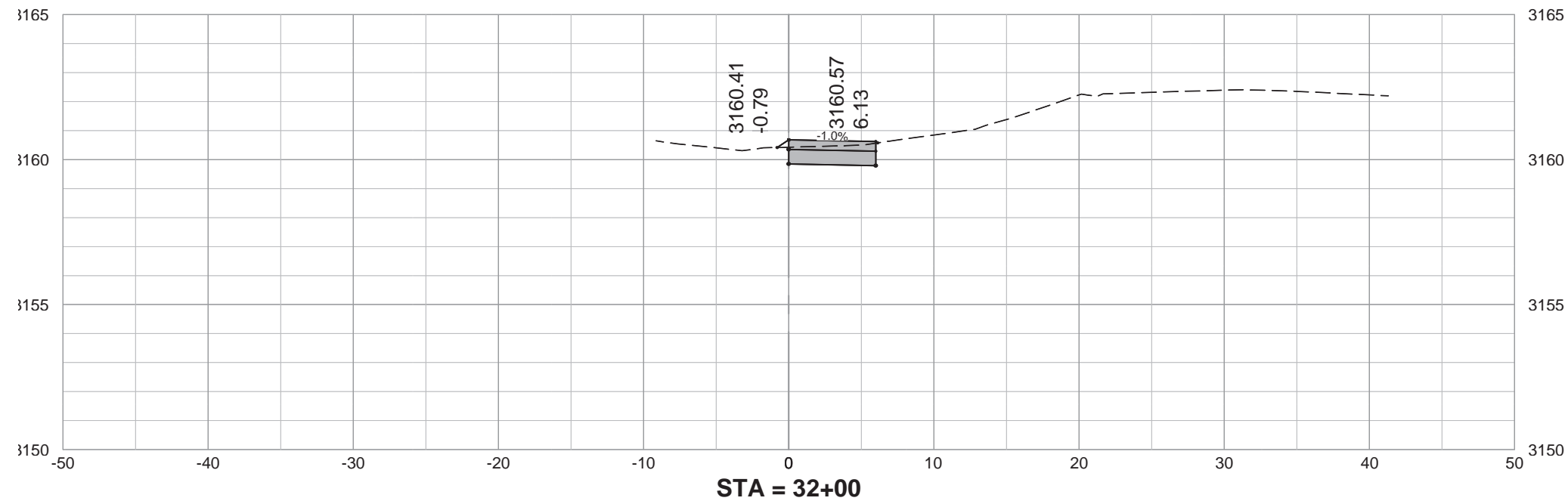
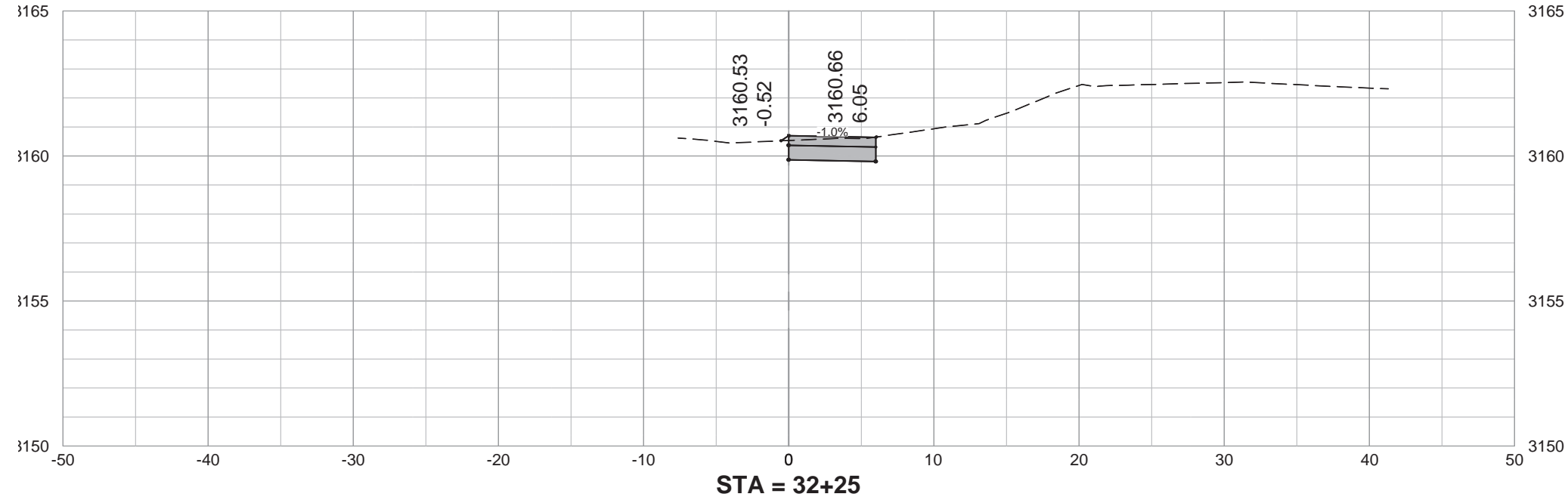

FOR BIDDING PURPOSES ONLY



PROJECT	SHEET	TOTAL SHEETS
P TAPU(47)	98	112

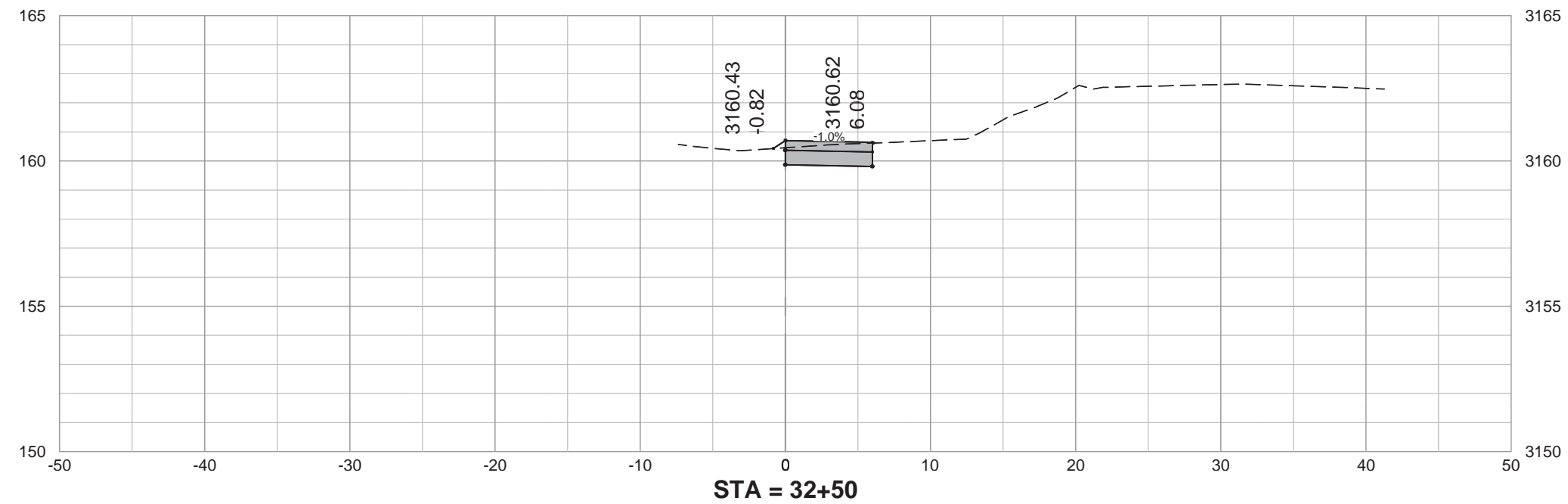
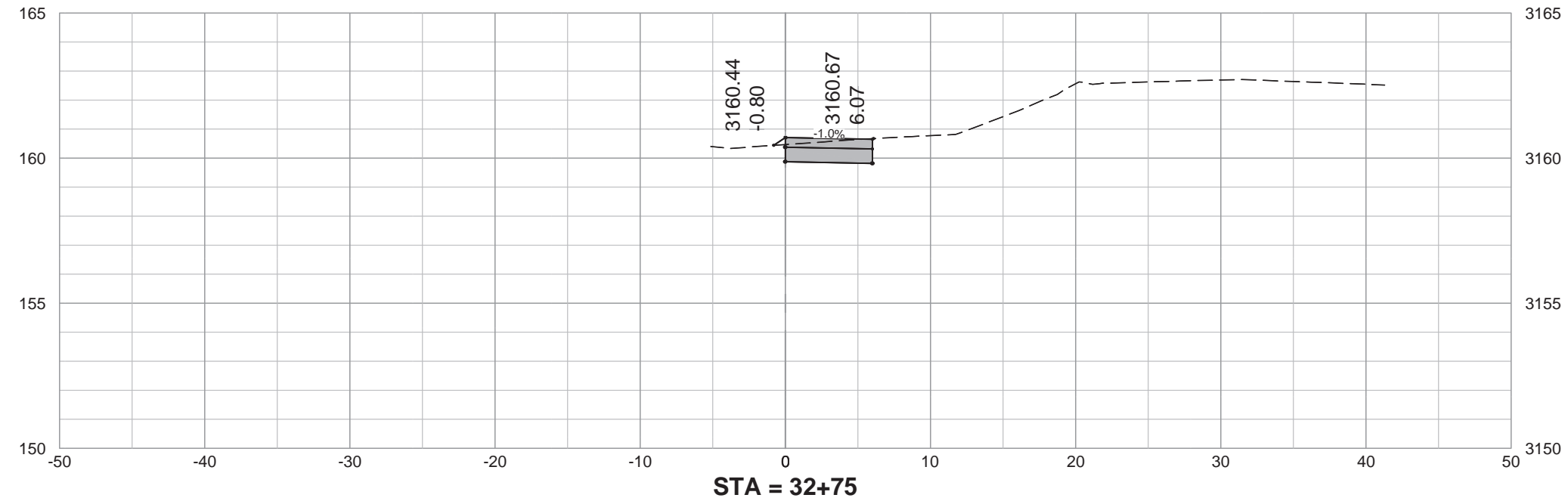

FOR BIDDING PURPOSES ONLY



PROJECT	SHEET	TOTAL SHEETS
P TAPU(47)	99	112

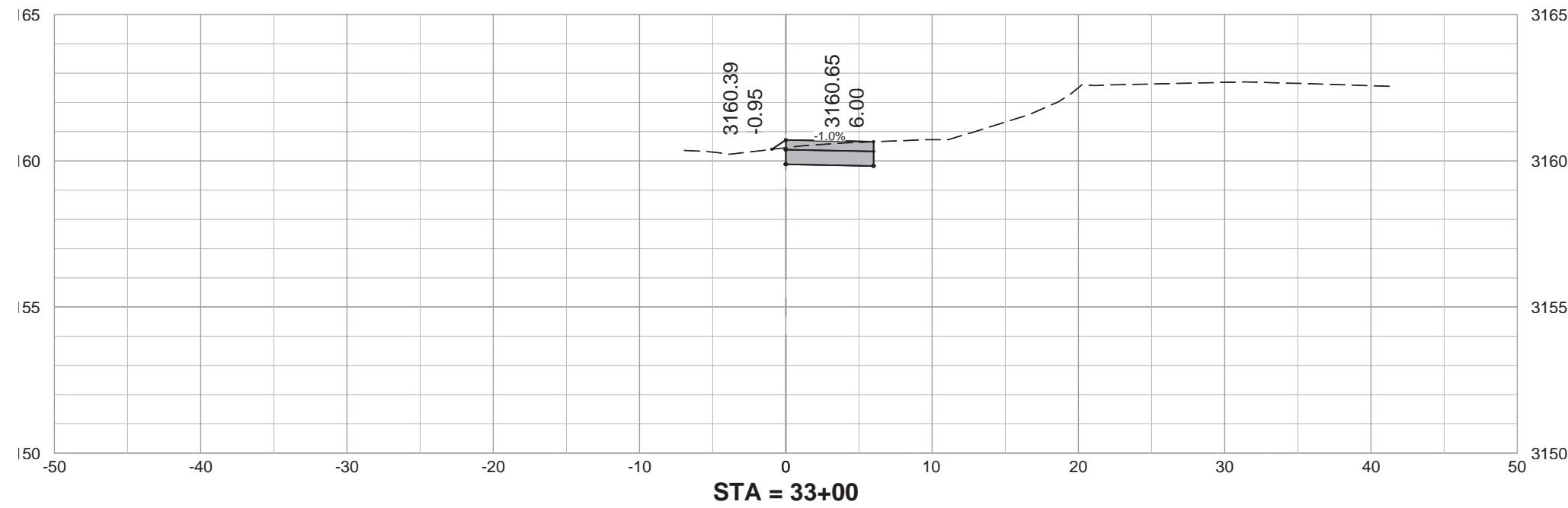
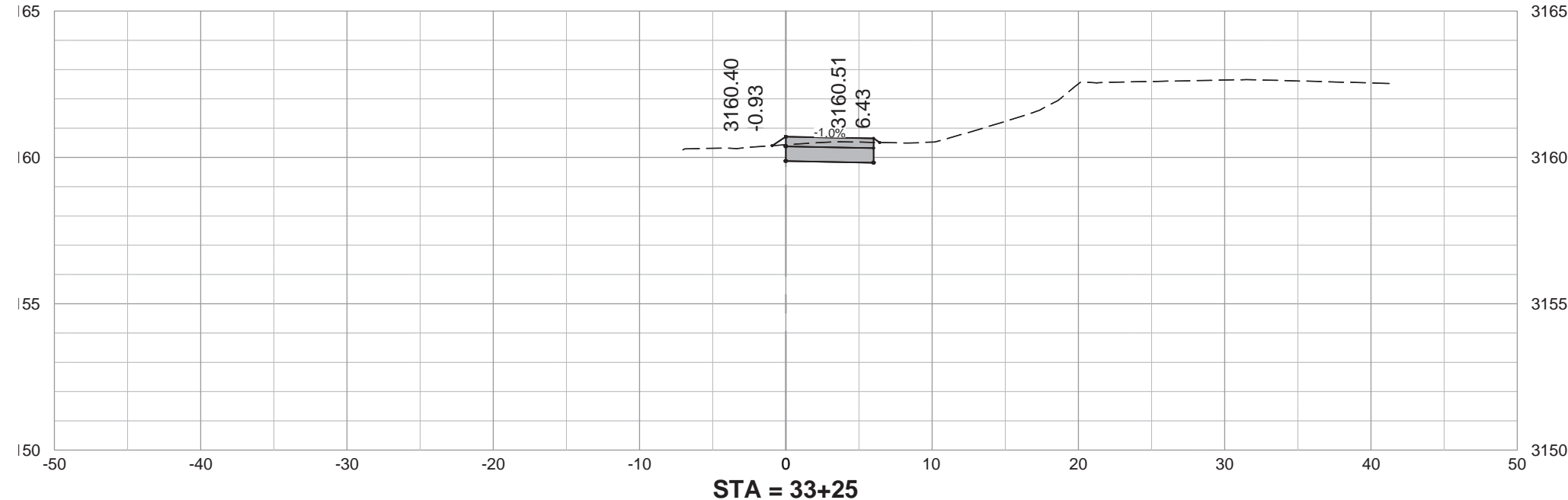

FOR BIDDING PURPOSES ONLY



PROJECT	SHEET	TOTAL SHEETS
P TAPU(47)	100	112

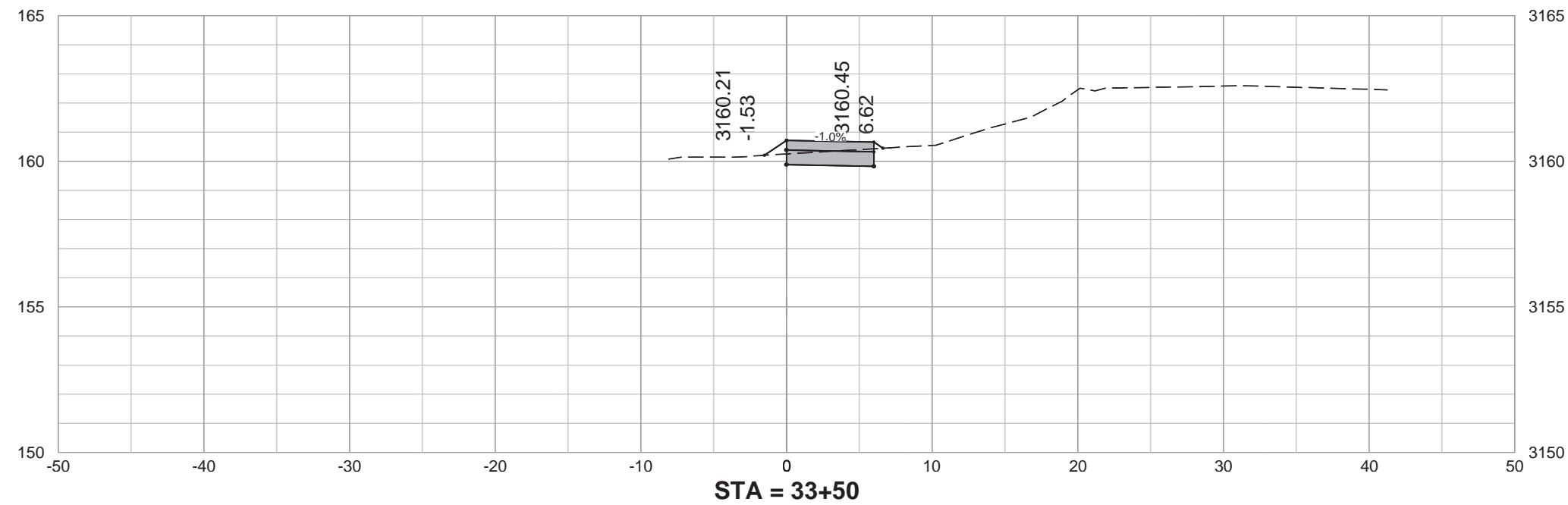
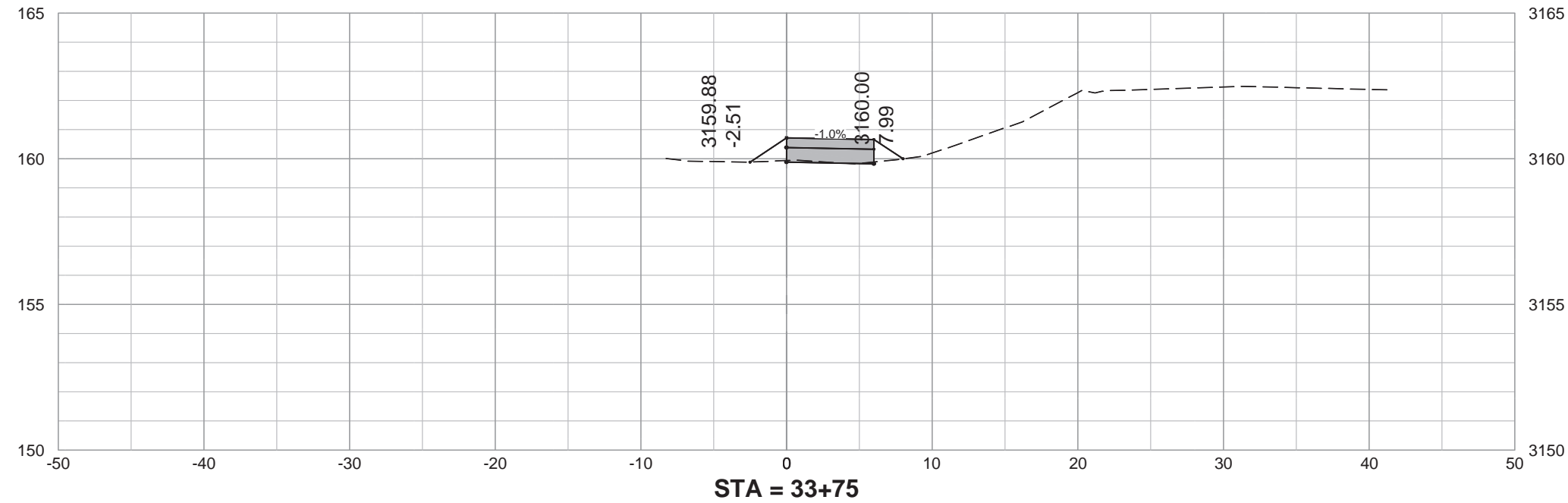

FOR BIDDING PURPOSES ONLY



PROJECT	SHEET	TOTAL SHEETS
P TAPU(47)	101	112

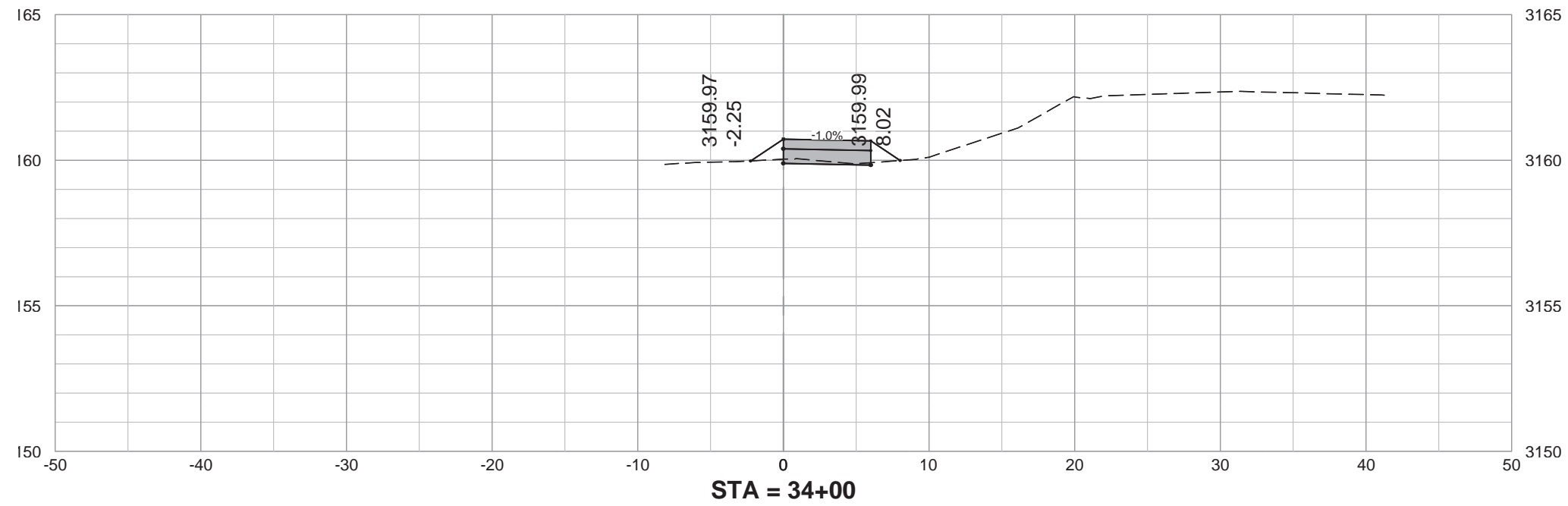
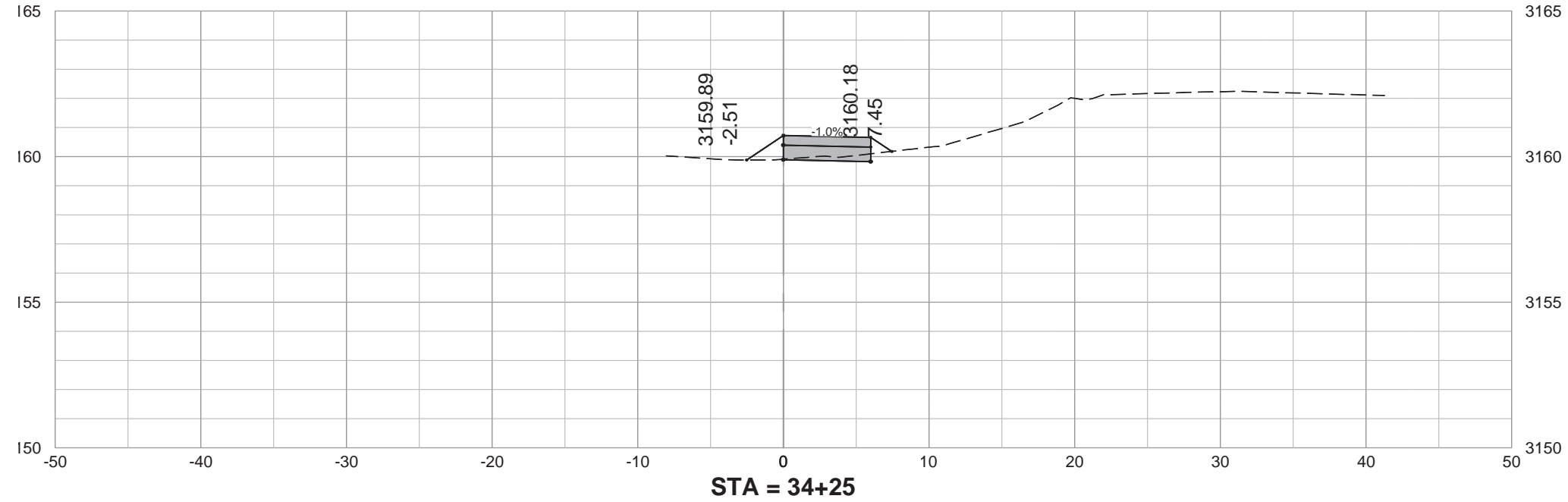

FOR BIDDING PURPOSES ONLY



PROJECT	SHEET	TOTAL SHEETS
P TAPU(47)	102	112

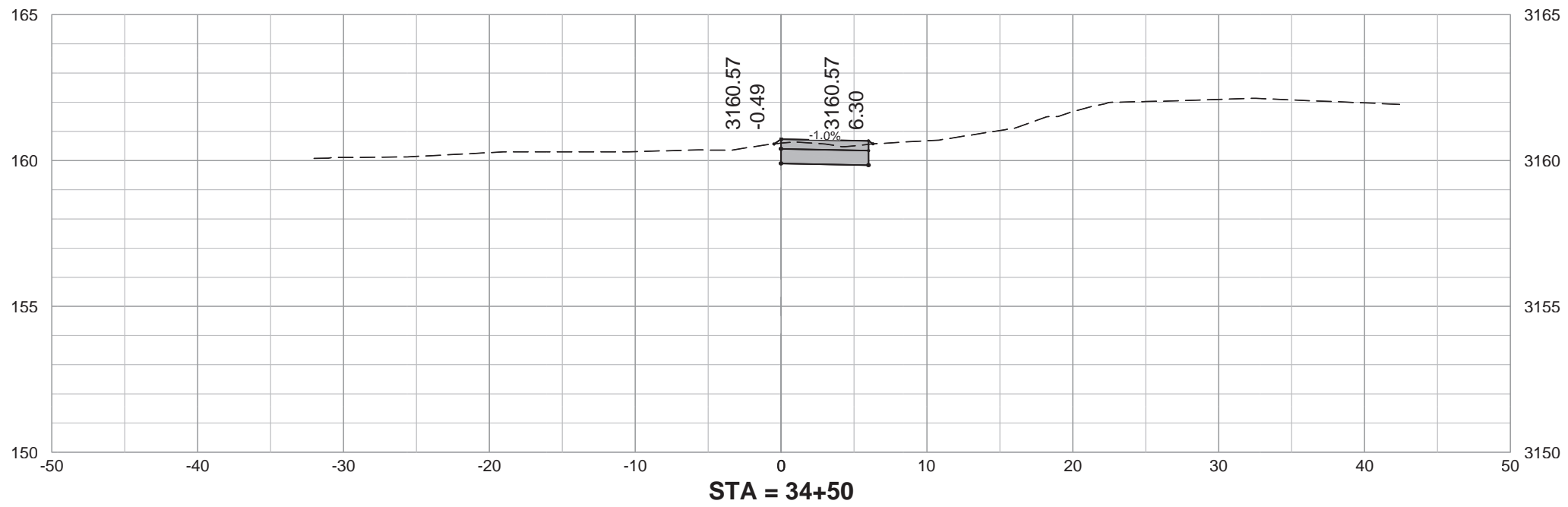

FOR BIDDING PURPOSES ONLY



PROJECT	SHEET	TOTAL SHEETS
P TAPU(47)	103	112

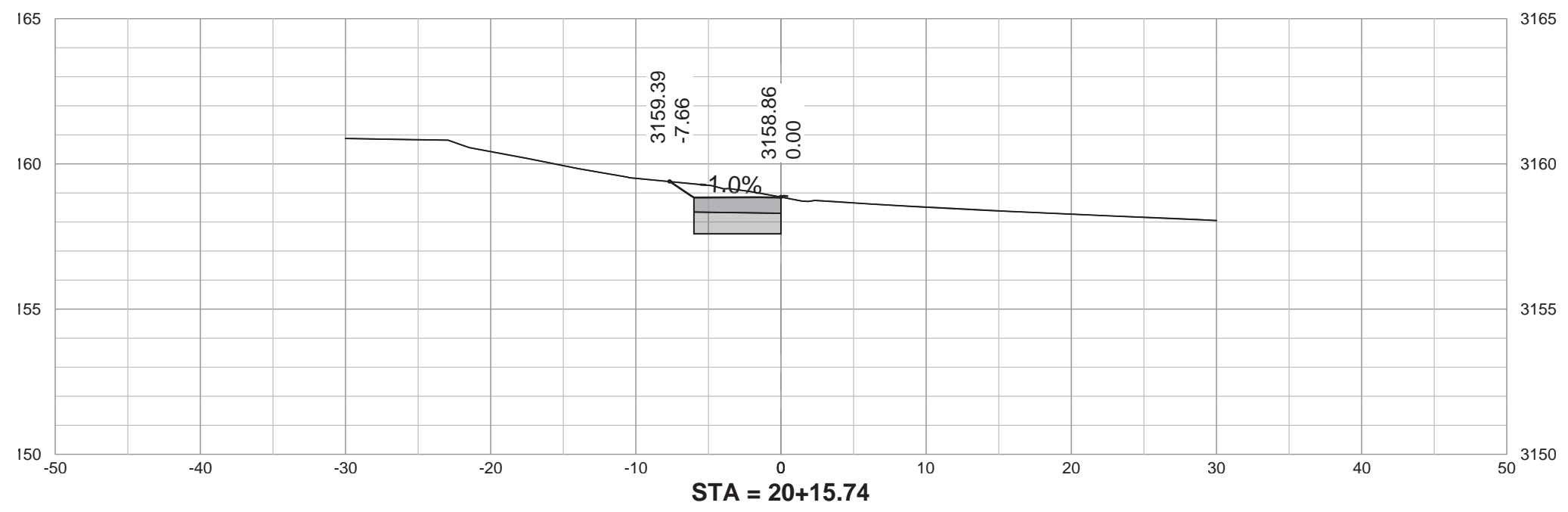
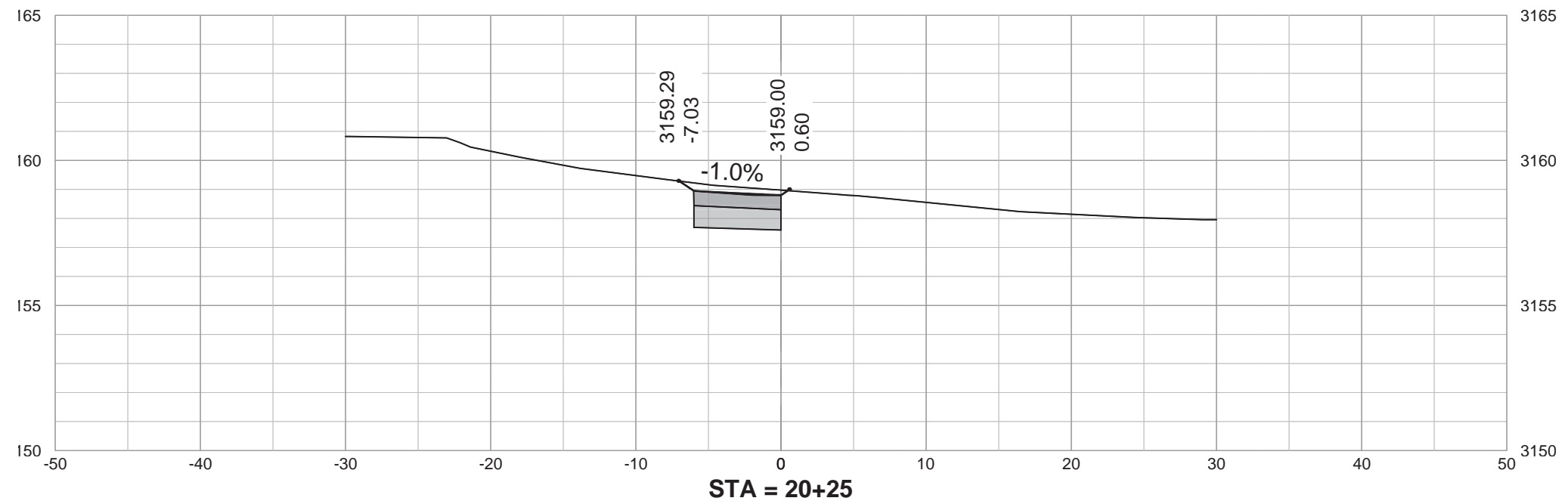

FOR BIDDING PURPOSES ONLY



PROJECT	SHEET	TOTAL SHEETS
P TAPU(47)	104	112

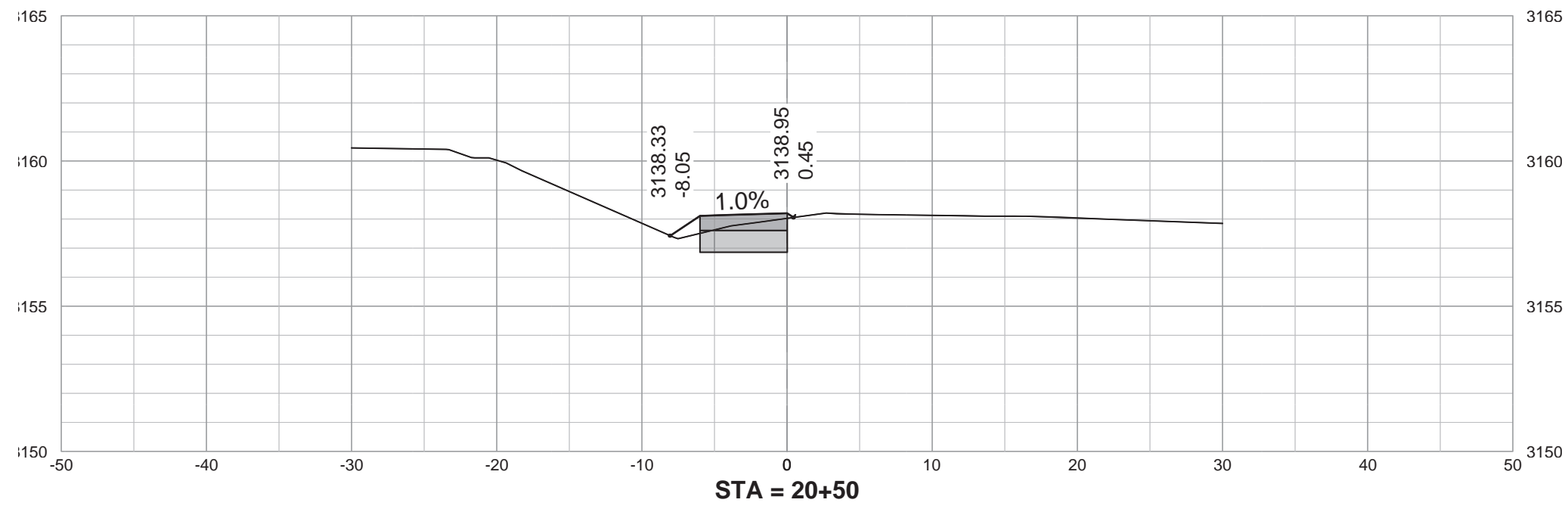
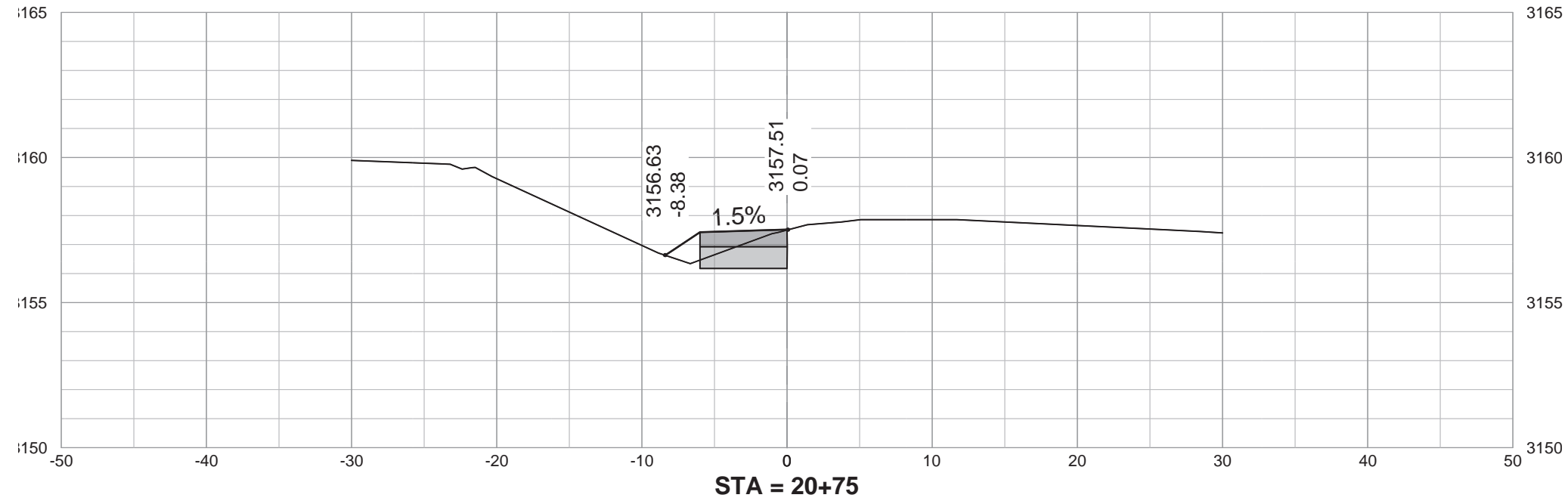

FOR BIDDING PURPOSES ONLY



PROJECT	SHEET	TOTAL SHEETS
P TAPU(47)	105	112

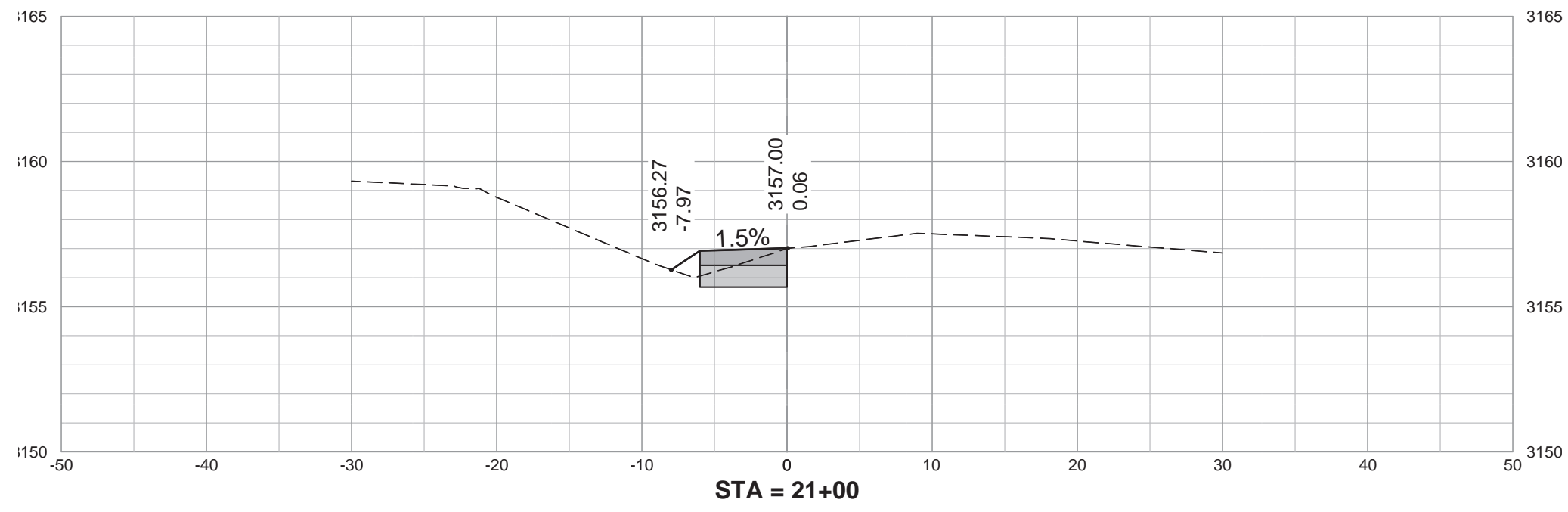
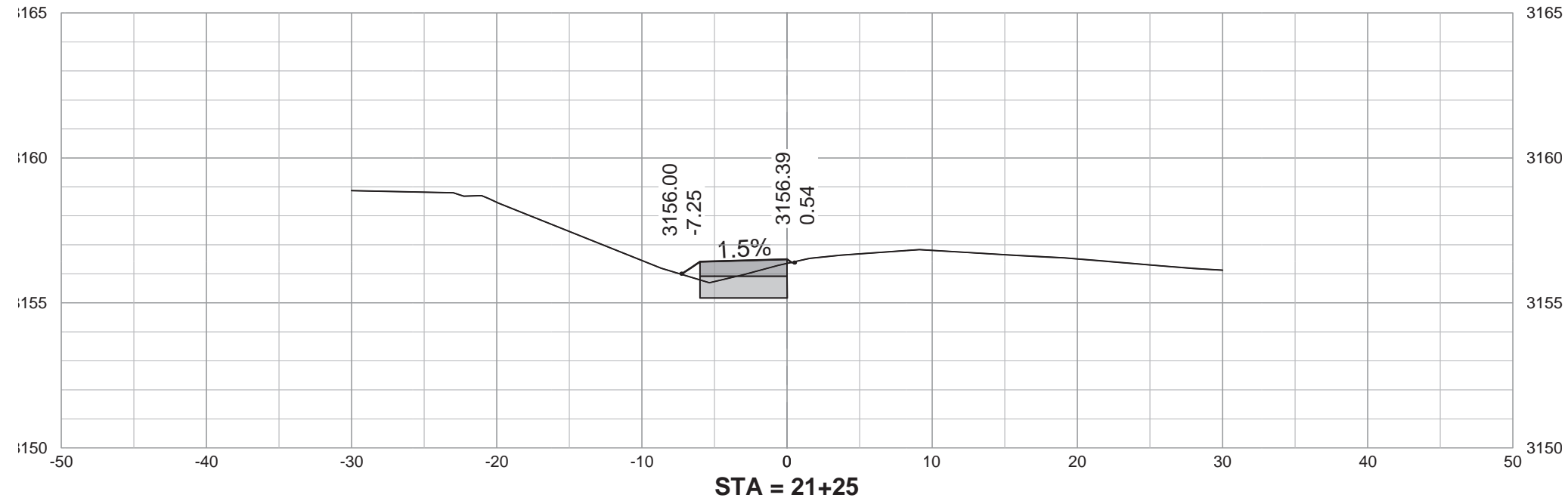

FOR BIDDING PURPOSES ONLY



PROJECT	SHEET	TOTAL SHEETS
P TAPU(47)	106	112

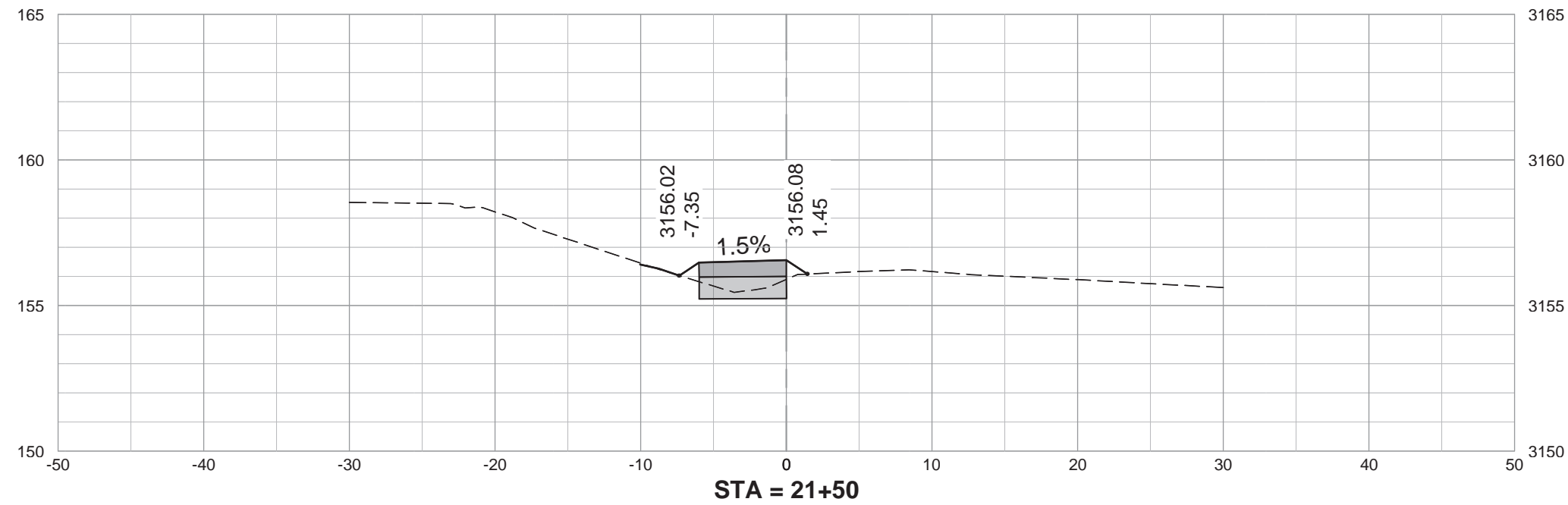
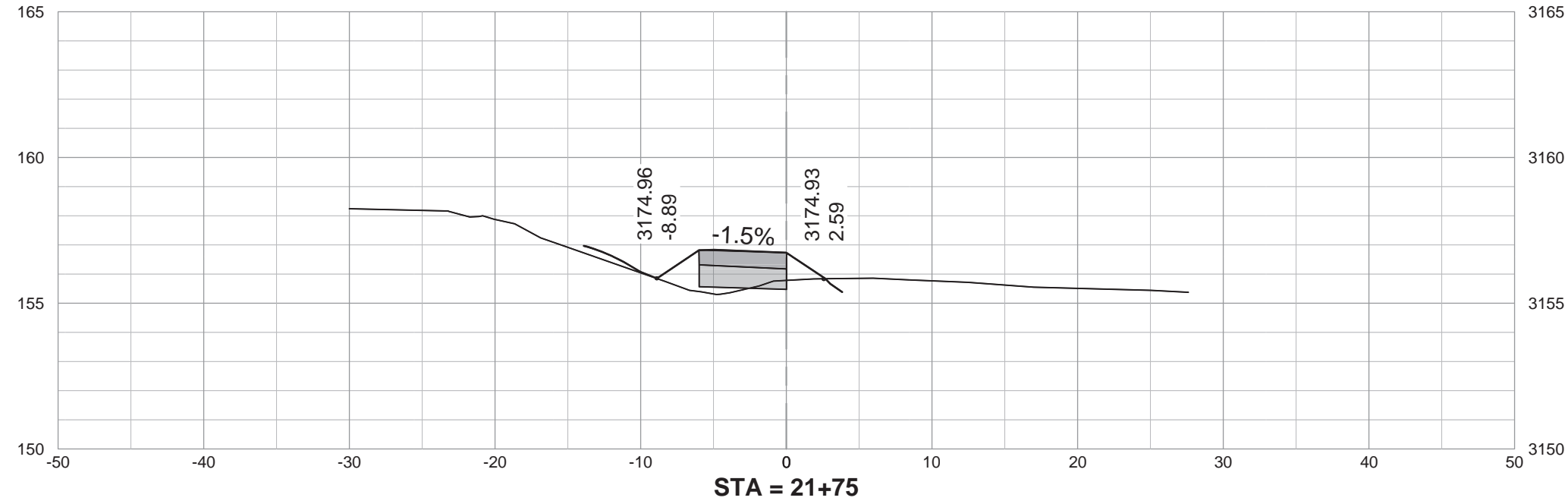

FOR BIDDING PURPOSES ONLY



PROJECT	SHEET	TOTAL SHEETS
P TAPU(47)	107	112

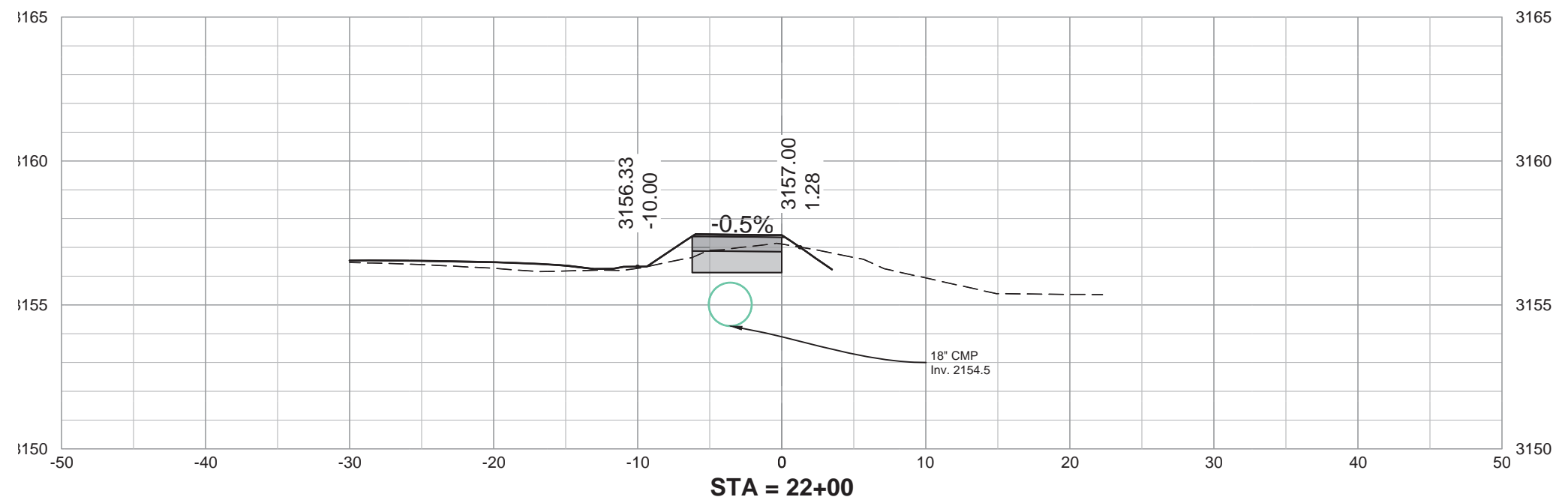

FOR BIDDING PURPOSES ONLY



PROJECT	SHEET	TOTAL SHEETS
P TAPU(47)	108	112

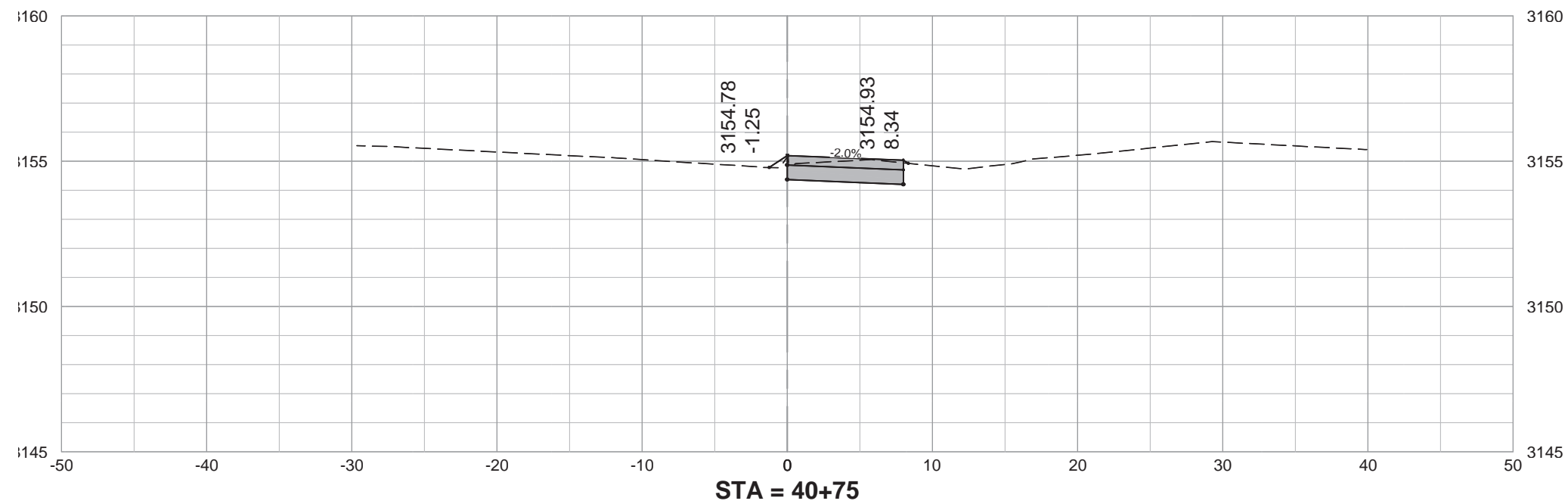
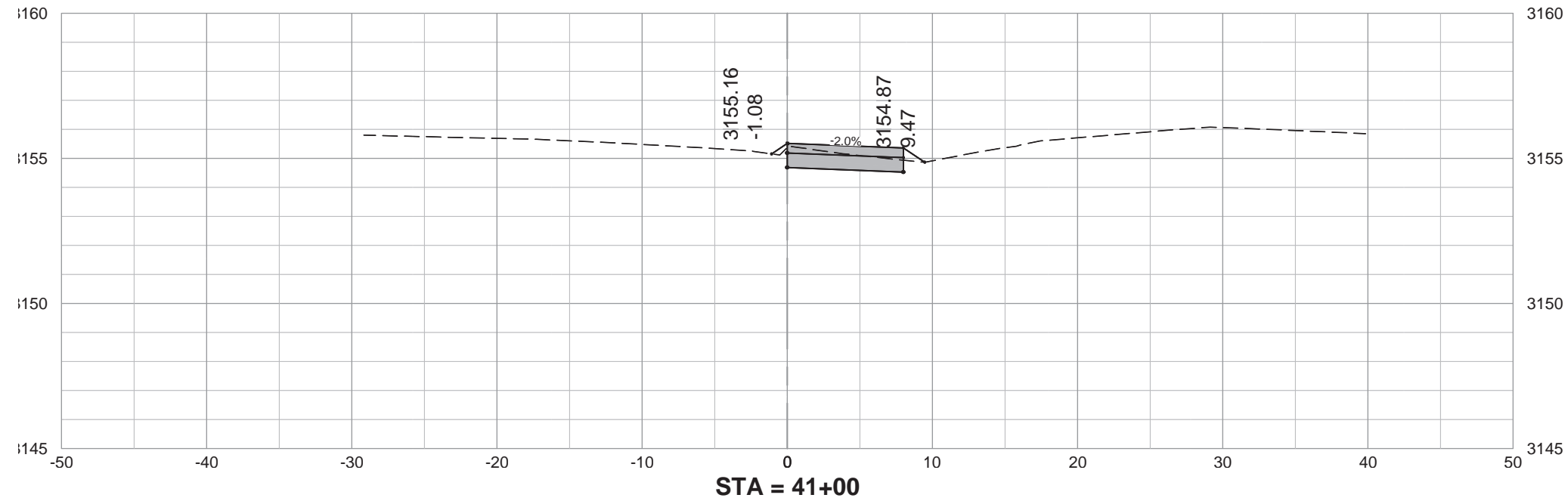

FOR BIDDING PURPOSES ONLY



PROJECT	SHEET	TOTAL SHEETS
P TAPU(47)	109	112

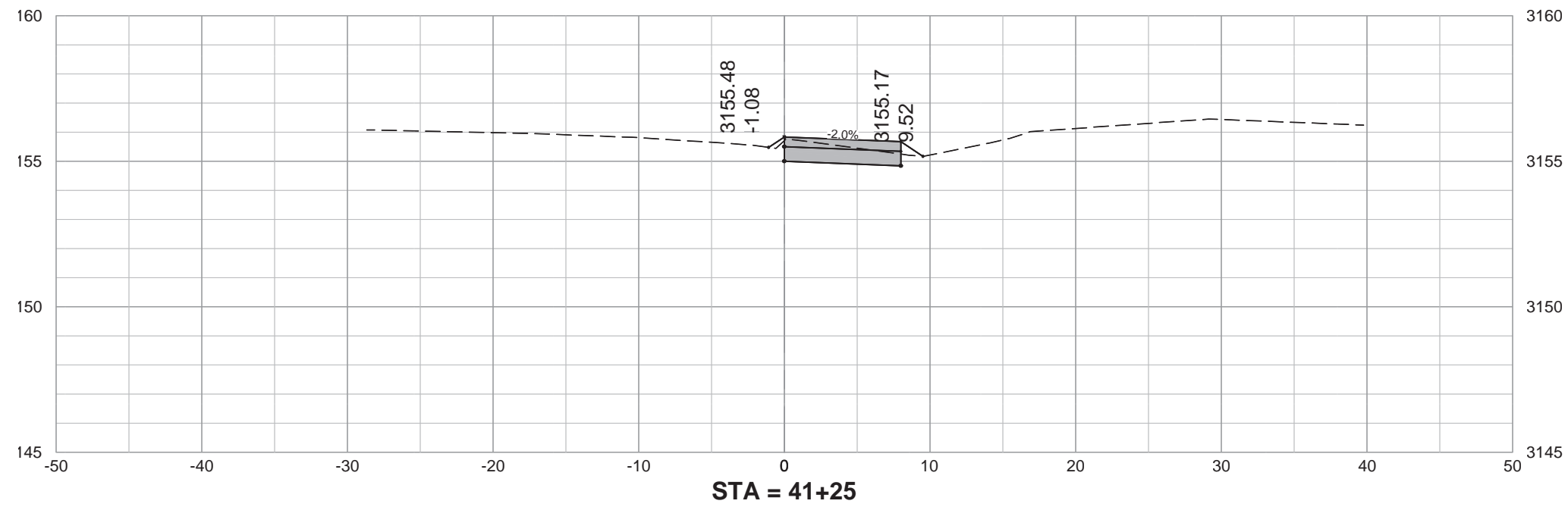
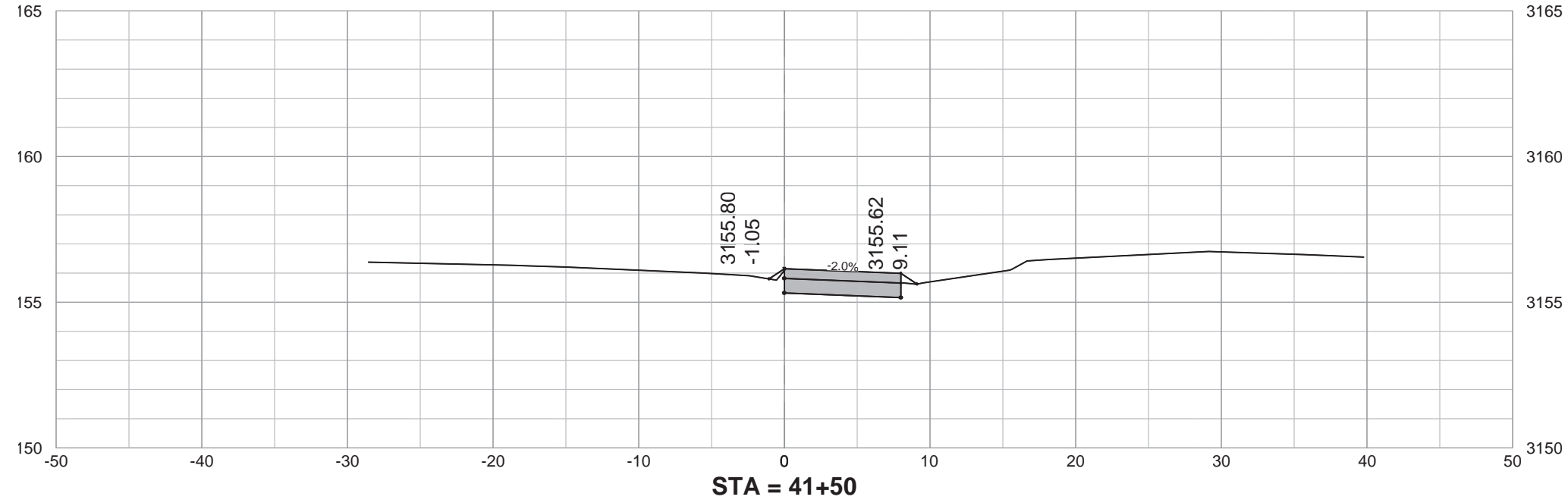

FOR BIDDING PURPOSES ONLY



PROJECT	SHEET	TOTAL SHEETS
P TAPU(47)	110	112

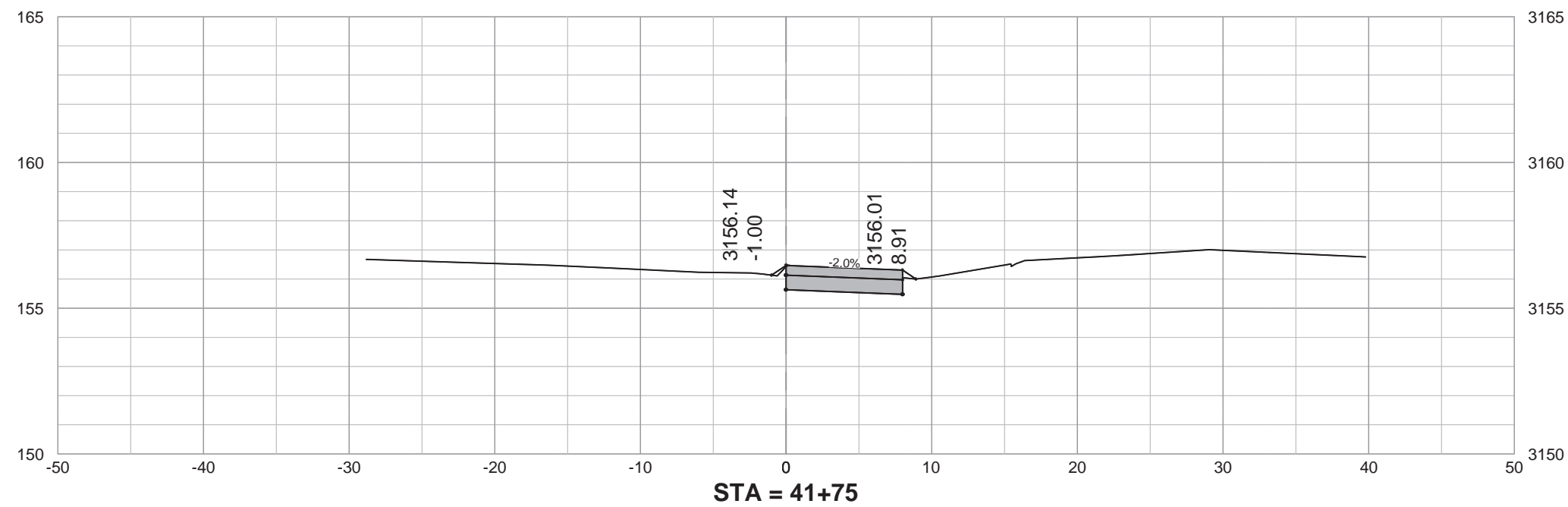
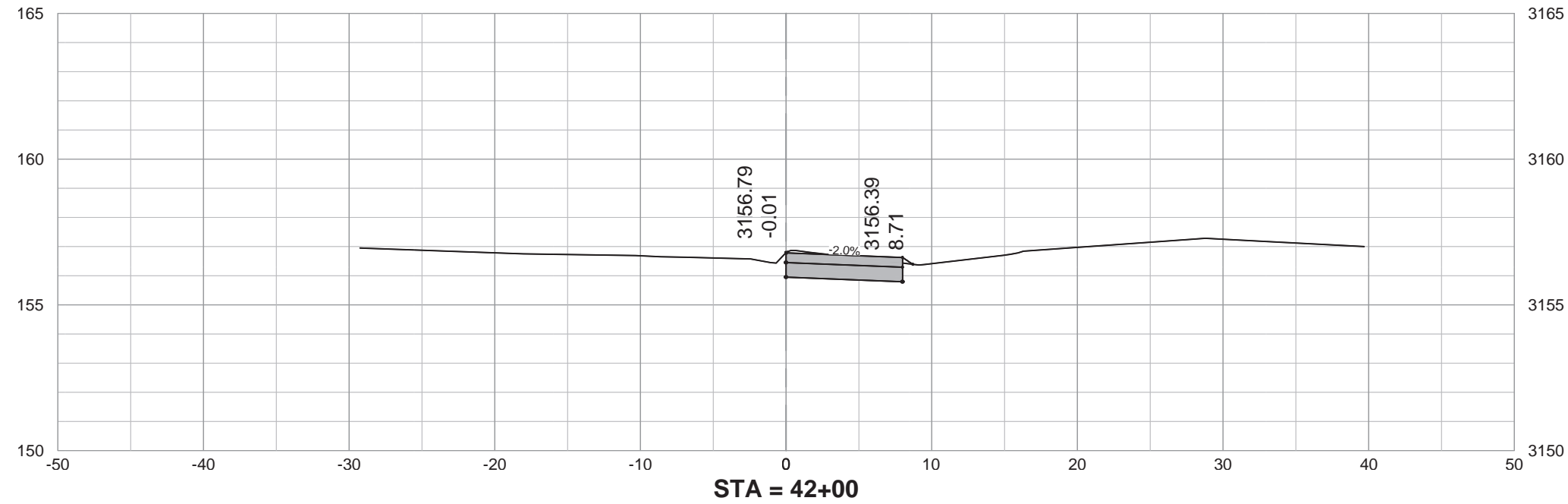

FOR BIDDING PURPOSES ONLY



PROJECT	SHEET	TOTAL SHEETS
P TAPU(47)	111	112

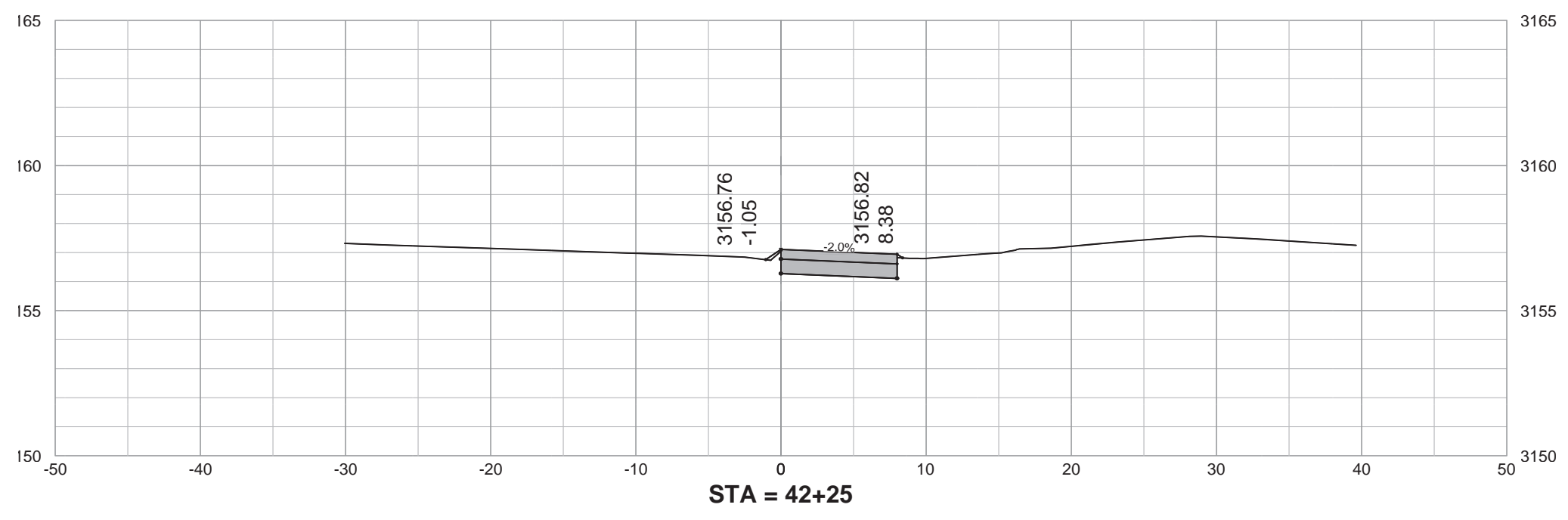
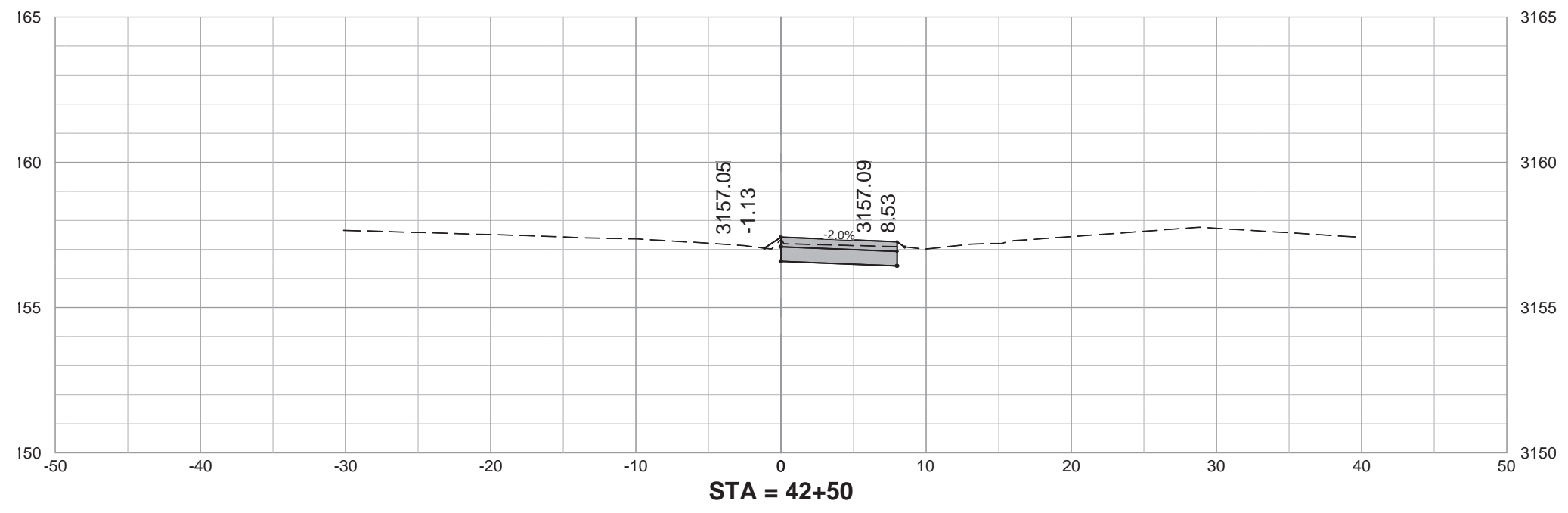

FOR BIDDING PURPOSES ONLY



PROJECT	SHEET	TOTAL SHEETS
P TAPU(47)	112	112

