

ABERDEEN AREA

UPDATED 5/4/09

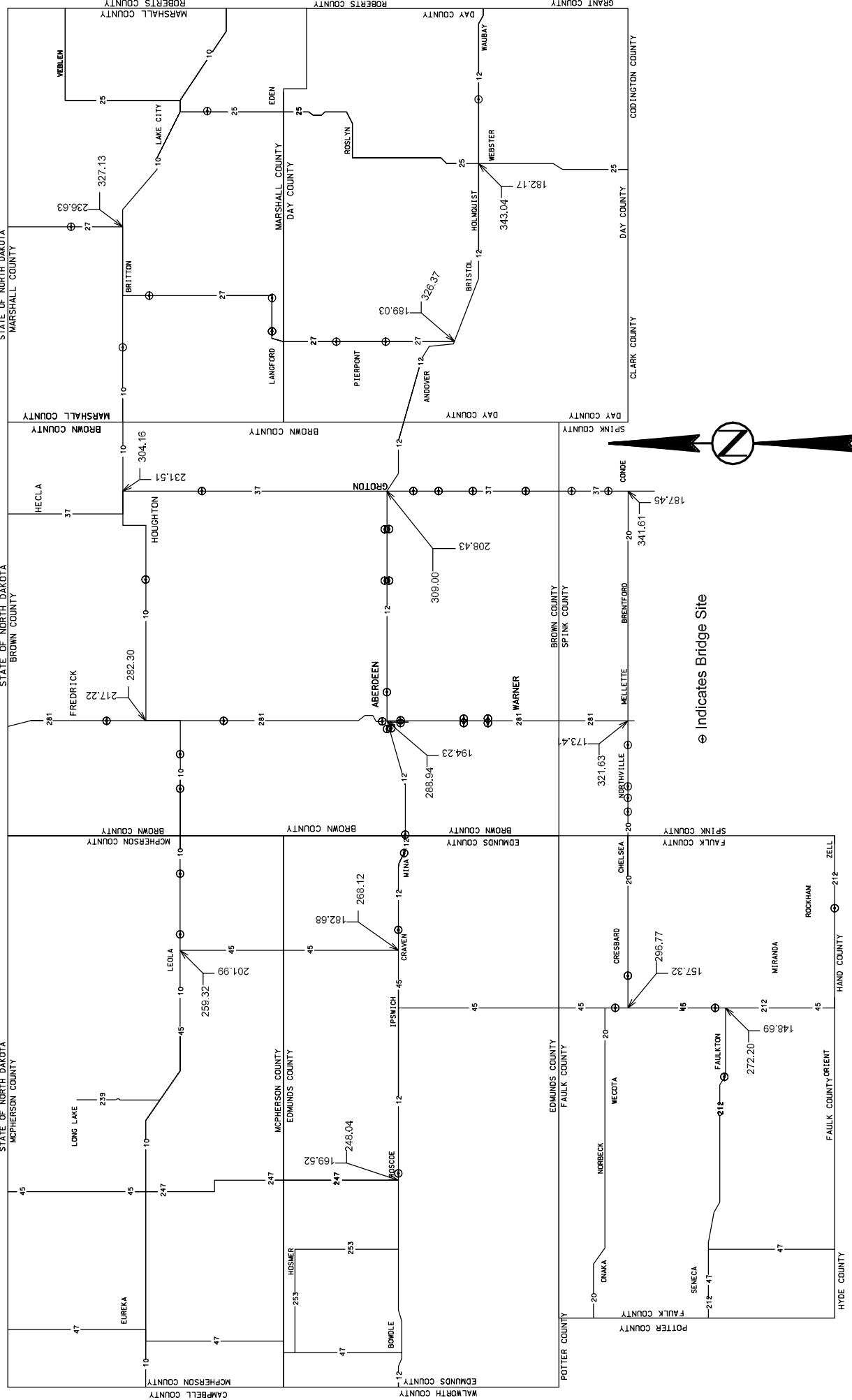

HURON AREA

UPDATED 11/5/97

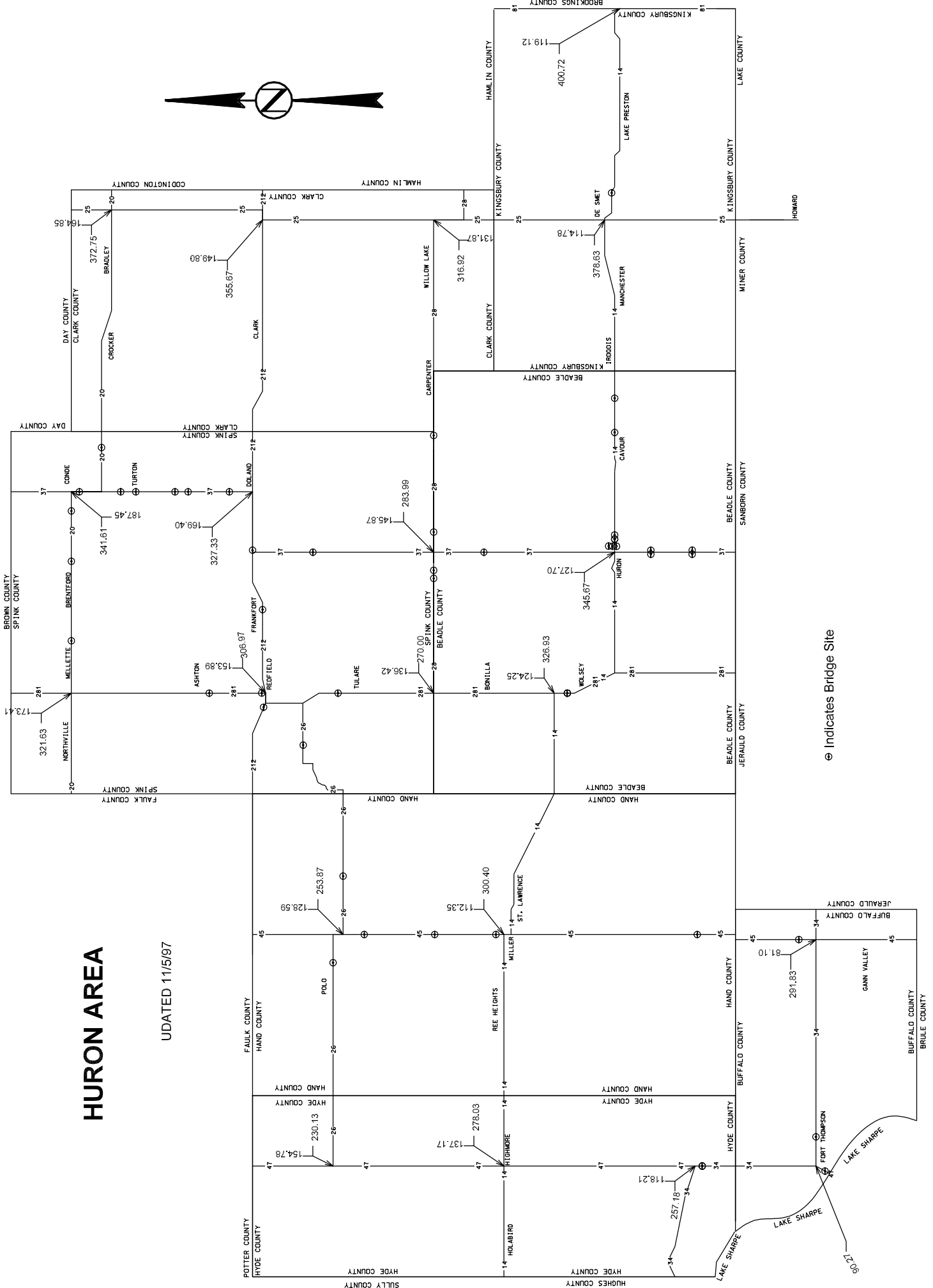

⊙ Indicates Bridge Site

GUARDRAIL ACCIDENT DAMAGE REPAIR

BEADLE, BROOKINGS, BROWN, BUFFALO, CLARK, CODINGTON, DAY, DEUEL, EDMUNDS, FAULK, GRANT, HAMLIN, HAND, HYDE, KINGSBURY, MCPHERSON, MARSHALL, MOODY, ROBERTS, AND SPINK COUNTIES

CONTRACT PROVISIONS

1. The Contract will become effective beginning July 1, 2009 and will expire on June 30, 2010.
2. Guardrail repairs will be limited to Interstate and State Highways within the boundaries of Beadle, Brookings, Brown, Buffalo, Clark, Codington, Day, Deuel, Edmunds, Faulk, Grant, Hamlin, Hand, Hyde, Kingsbury, McPherson, Marshall, Moody, Roberts, and Spink Counties.
3. Standard Specifications for Roads and Bridges, 2004 Edition and Required Provisions, Supplemental Specifications and/or Special Provisions as included in the Proposal shall apply to this contract. Guardrail repair shall conform to current Department of Transportation Standards or as directed by the Engineer.
4. The quantities shown on the SDDOT CONTRACT PROPOSAL are estimated quantities only, based upon previous years quantities. The actual amount of work accomplished may vary greatly from the quantities shown. There will be NO negotiation of contract unit bid prices for over-runs or under-runs.
5. All repair items shall be furnished new by the Contractor. Should some guardrail items be required that are not bid, the Contractor will be paid for invoice cost of the item(s) plus shipping charges, taxes and ten percent for profit. Approval from the Area Engineer will be required prior to the purchase of non-bid item materials.

All costs to furnish and install new bolts, nuts, washers, nails, and other miscellaneous items shall be incidental to the various other bid items.

All damaged and replaced materials shall become the property of the Contractor for his disposal.

6. Any damage to the roadway surfacing, embankment, vegetation, signing, etc. which occurs during guardrail repair operations shall be repaired and/or restored by the Contractor, at no expense to the State, and to the satisfaction of the Engineer.
7. The Contractor will be notified at such time as repairs are required. The Contractor shall complete all necessary repairs within twenty-one (21) calendar days after notification. For each day after the 21 calendar day limitation, the Contractor will be assessed liquidated damages at the rate of \$200.00 per day.
8. Definition of Contract Items:
 - A. **Mobilization 1:** Mobilization 1 (Aberdeen Area) shall include all costs of mobilization within the Aberdeen Area to and from the project and will be paid on a per each basis each time the Contractor is called in by the Area Engineer to perform guardrail accident damage repair. The Aberdeen Area includes the following counties: Brown, Day, Edmunds, Faulk, McPherson, and Marshall Counties.

GUARDRAIL ACCIDENT DAMAGE REPAIR

BEADLE, BROOKINGS, BROWN, BUFFALO, CLARK, CODINGTON, DAY, DEUEL, EDMUNDS, FAULK, GRANT, HAMLIN, HAND, HYDE, KINGSBURY, MCPHERSON, MARSHALL, MOODY, ROBERTS, AND SPINK COUNTIES

- B. **Mobilization 2:** Mobilization 2 (Huron Area) shall include all costs of mobilization within the Huron Area to and from the project and will be paid on a per each basis each time the Contractor is called in by the Area Engineer to perform guardrail accident damage repair. The Huron Area includes the following counties: Beadle, Buffalo, Clark, Hand, Hyde, Kingsbury, and Spink Counties.
- C. **Mobilization 3:** Mobilization 3 (Watertown Area) shall include all costs of mobilization within the Watertown Area to and from the project and will be paid on a per each basis each time the Contractor is called in by the Area Engineer to perform guardrail accident damage repair. The Watertown Area includes the following counties: Brookings, Codington, Deuel, Grant, Hamlin, Moody and Roberts Counties.
- D. **Retension 3 Cable Guardrail:** Retension 3 Cable Guardrail shall include all costs to adjust the tension in a length of 3 Cable Guardrail. The tension shall be as shown on Standard Plate 629.01 (1 of 6). Measurement for payment will be per each run of 3 Cable Guardrail and shall include all 3 cables and both anchor ends that make up a run of 3 Cable Guardrail. Retension 3 Cable Guardrail may include cutting and shortening of cables at the anchors to allow for the proper retensioning.
- E. **Repair 3 Cable Guardrail:** Repair 3 Cable Guardrail shall include replacement of damaged cable. The Contractor shall furnish any J Hook Bolts needed as shown on Standard Plate 629.01 (5 of 6). Measurement for payment will be per each single cable and for the actual length requiring replacement. Cable Splices required shall be incidental to this contract item. All costs for retensioning of cables shall be incidental to the contract unit price per foot for "Repair 3 Cable Guardrail".
- F. **3 Cable Guardrail End Post:** 3 Cable Guardrail End Post shall include all costs for removal of damaged end post and installation of 3 cable guardrail end post. 3 Cable Guardrail End Post shall also include a new end post cap. All costs incurred for removal and replacement of the existing cable on the new post shall be incidental to this contract item.
- G. **3 Cable Guardrail Intermediate Post:** 3 Cable Guardrail Intermediate Post shall include all costs for removal of damaged post and installation of 3 cable guardrail intermediate line post. All costs incurred for removal and replacement of the existing cable on the new post, including J Hook Bolts shall be incidental to this contract item.
- H. **3 Cable Guardrail Slip Base Anchor Post:** 3 Cable Guardrail Slip Base Anchor Post shall include all costs for removal of damaged post and installation of 3 cable guardrail slip base anchor post. All costs incurred for removal and replacement of the existing cable on the new post, shall be incidental to this contract item.
- I. **3 Cable Guardrail Post, Winter:** 3 Cable Guardrail Post, Winter shall include all costs for removal of the damaged post and installation of cable guardrail post when there is in excess of one foot of frozen ground at the work site. When this condition exists, the contract unit price per each for "3 Cable Guardrail Post, Winter" will be the pay unit rather than the contract unit price per each for "3 Cable Guardrail Intermediate Post" and/or "3 Cable Guardrail End Post". The Contractor shall furnish any J Hook Bolts needed as shown on Standard Plate 629.01 (5 of 6).

All costs incurred for removal and replacement of the existing cable on the new post, including J Hook Bolts shall be incidental to this contract item.

GUARDRAIL ACCIDENT DAMAGE REPAIR

BEADLE, BROOKINGS, BROWN, BUFFALO, CLARK, CODINGTON, DAY, DEUEL, EDMUNDS, FAULK, GRANT, HAMLIN, HAND, HYDE, KINGSBURY, MCPHERSON, MARSHALL, MOODY, ROBERTS, AND SPINK COUNTIES

- J. **Drive Down 3 Cable Guardrail Post:** Drive Down 3 Cable Guardrail Post shall include all costs for adjusting the height of a Cable Rail Post. All costs to disassemble the cable rail to do this work shall be incidental to this contract item.
- K. **Reset 3 Cable Guardrail Post:** Reset 3 Cable Guardrail Post shall include all costs incurred for the realignment and/or removal and resetting of a cable guardrail post to properly align cable guardrail section. The Contractor shall furnish any J Hook Bolts needed as shown on Standard Plate 629.01 (5 of 6).
- Work under this item may require straightening of in place bent cable guardrail posts to bring them into alignment with cable guardrail section. Payment for "Reset 3 Cable Guardrail Post" will be the same whether in frozen or unfrozen ground. All costs incurred for removal and replacement of the existing cable on the new post shall be incidental to this item.
- L. **Cable Anchor Bracket:** Cable Anchor Bracket shall include furnishing and installing the Cable Anchor Bracket as shown on Standard Plate 629.01 (3 of 6).
- M. **Cable Splice:** Cable Splice shall include all costs incurred for cutting existing cable and for furnishing and installing the necessary cable splice.
- N. **3 Cable Guardrail J Hook Bolt:** 3 Cable Guardrail J Hook Bolt shall include furnishing & installing J hook bolts when no other work is required to the 3 cable guardrail other than missing or broken J hook bolts.
- O. **Steel Turnbuckle Cable End Assembly:** Steel Turnbuckle Cable End Assembly shall include all costs for furnishing and installing the Steel Turnbuckle Cable End Assembly as shown on Standard Plate 629.01 (4 of 6).
- P. **Spring Cable End Assembly with Turn Buckle:** Spring Cable End Assembly with Turnbuckle shall include all costs for furnishing and installing the Spring Cable End Assembly with Turnbuckle as shown on Standard Plate 629.01 (4 of 6).
- Q. **W Beam to 3 Cable Transition Bracket:** W Beam to 3 Cable Transition Bracket shall include all costs incurred for removing the damaged transition bracket and installing a transition bracket in accordance with the details on Standard Plates 629.05 & 629.15.
- R. **3 Cable Guardrail End Post Cap:** 3 Cable Guardrail End Post Cap shall include all costs for furnishing and installing an end post cap as shown on Standard Plate 629.01 (6 of 6).
- S. **Straight Class A Thrie Beam Rail:** Straight Class A Thrie Beam Rail shall include all costs for removing damaged Thrie Beam rail and replacing with Class A Thrie Beam rail.
- T. **Straight Class A W Beam Rail:** Straight Class A W Beam Rail shall include all costs for removing damaged W Beam rail and replacing with Class A W Beam rail.
- U. **Straight Class B W Beam Rail:** Straight Class B W Beam Rail shall include all costs for removing damaged W Beam rail and replacing with Class B W Beam rail.

GUARDRAIL ACCIDENT DAMAGE REPAIR

BEADLE, BROOKINGS, BROWN, BUFFALO, CLARK, CODINGTON, DAY, DEUEL, EDMUNDS, FAULK, GRANT, HAMLIN, HAND, HYDE, KINGSBURY, MCPHERSON, MARSHALL, MOODY, ROBERTS, AND SPINK COUNTIES

V. **W Beam to Thrie Beam Guardrail Transition:** W Beam to Thrie Beam Guardrail Transition shall include all costs for removing damaged rail and replacing with a W Beam to Thrie Beam Guardrail Transition.

W. **W Beam Guardrail Flared End Terminal:** W Beam Guardrail Flared End Terminal shall include all costs incurred for furnishing and installing an approved end terminal in accordance with details on Standard Plate 630.45. At some locations of W beam damage, the Area Engineer may decide to replace the existing "Texas Twist" terminal end, Breakaway Cable Terminal (BCT) end or Modified Eccentric Loader Terminal (MELT) end with a Flared End Terminal.

The Flared End Terminal shall be on the approved products list on Sheet [11](#) of [45](#).

Prior to installation of a Flared End Terminal, the Contractor shall place additional embankment to accommodate the Flared End Terminal in accordance with Standard Plate 630.45. Embankment material shall be obtained by the Contractor from a source approved by the Engineer. Compaction of the embankment material shall be to the satisfaction of the Engineer.

The contract unit price per each for "W Beam Guardrail Flared End Terminal" shall include all costs incurred for furnishing and installing one (1) end section as shown on Standard Plate 630.45 including construction of the additional embankment and surfacing.

X. **W Beam Guardrail Tangent End Terminal:** W Beam Guardrail Tangent End Terminal shall include all costs incurred for furnishing and installing an approved end terminal in accordance with details on Standard Plate 630.46. At some locations of W beam damage, the Area Engineer may decide to replace the existing "Texas Twist" terminal end, Breakaway Cable Terminal (BCT) end or Modified Eccentric Loader Terminal (MELT) end with a Tangent End Terminal.

The Tangent End Terminal shall be on the approved products list on Sheet [11](#) of [45](#).

Prior to installation of a Tangent End Terminal, the Contractor shall place additional embankment to accommodate the Tangent End Terminal in accordance with Standard Plate 630.46. Embankment material shall be obtained by the Contractor from a source approved by the Engineer. Compaction of the embankment material shall be to the satisfaction of the Engineer.

The contract unit price per each for "W Beam Guardrail Tangent End Terminal" shall include all costs incurred for furnishing and installing one (1) end section as shown on Standard Plate 630.46 including construction of the additional embankment and surfacing.

Y. **Beam Guardrail Block:** Beam Guardrail Block shall include all costs for removing the broken block and installing a block.

Z. **Beam Guardrail Post & Block:** Beam Guardrail Post & Block shall include all costs for removing the broken post and installing a post and block. Any holes required to be drilled in the posts, such as the 3 1/2" diameter holes for the MELT end posts as per Standard Plate SPECIAL - A (3 of 3), shall also be included.

GUARDRAIL ACCIDENT DAMAGE REPAIR

BEADLE, BROOKINGS, BROWN, BUFFALO, CLARK, CODINGTON, DAY, DEUEL, EDMUNDS, FAULK, GRANT, HAMLIN, HAND, HYDE, KINGSBURY, MCPHERSON, MARSHALL, MOODY, ROBERTS, AND SPINK COUNTIES

- AA. **Beam Guardrail Post & Block, Winter:** Beam Guardrail Post & Block, Winter shall include all costs incurred for replacement of a steel beam guardrail post when there is in excess of one foot of frozen ground at the work site. When this condition exists, the contract unit price per each for "Beam Guardrail Post & Block, Winter" will be the pay unit rather than the contract unit price per each for "Beam Guardrail Post & Block". The Contractor shall field drill 3 1/2" diameter holes in posts as per Standard Plate SPECIAL - A (3 of 3) when placing MELT ends.
- BB. **Breakaway Cable Terminal End Post:** Breakaway Cable Terminal (B.C.T) End Post shall include all costs incurred for removal of a broken end post and installing an end post. B.C.T. end posts are set in concrete or in steel tube sleeves. The Contractor shall field drill holes in the installed post as required to accommodate the B.C.T.
- CC. **Breakaway Cable Terminal End Rail:** Breakaway Cable Terminal (B.C.T) End Rail shall include all costs incurred for removing the 12.5 ft. or 25 ft section of damaged B.C.T. W beam adjacent to the Radius Terminal Element and replacing with new guardrail. The Contractor shall field drill holes in the guardrail for installation.
- DD. **W-Beam Guardrail End Section Buffer:** W-Beam Guardrail End Section Buffer shall include all costs incurred for installing a buffer assembly. Removal of the existing end section buffer shall be incidental to this contract item.
- EE. **Tangent End Terminal Extruder Head:** Tangent End Terminal Extruder Head shall include all costs incurred for removing the damaged extruder head and installing a new extruder head on the Tangent End Terminal.
- FF. **Tangent End Terminal Wood Post:** Tangent End Terminal Wood Post shall include all costs incurred for removing the broken wood post and installing a new wood post within the steel tube footing on the Tangent End Terminal.
- GG. **Tangent End Terminal Wood Post & Block:** Tangent End Terminal Wood Post & Block shall include all costs incurred for removing the broken 6 ft. wood post and installing a new wood post and block on the Tangent End Terminal.
- HH. **Tangent End Terminal Rail:** Tangent End Terminal Rail shall include all costs incurred for removing 12.5 ft. or 25 ft. section(s) of damaged beam guardrail and replacing new beam guardrail on the Tangent End Terminal.
- II. **Rubrail:** Rubrail shall include all costs to install rubrail. The Contractor shall provide the necessary wood blocks and bolts to attach the rubrail to the wood posts.
- JJ. **Drive Down Beam Guardrail Post:** Drive Down Beam Guardrail Post shall include all costs for adjusting the height of a steel beam guardrail post. All costs to disassemble the steel beam guardrail shall be incidental to this bid item.
- KK. **Reset Beam Guardrail Post & Block:** Reset Beam Guardrail Post & Block shall include all costs for removing and resetting post to properly align the flex beam section. Payment for "Reset Beam Guardrail Post & Block" shall be the same in frozen or unfrozen ground.

GUARDRAIL ACCIDENT DAMAGE REPAIR

BEADLE, BROOKINGS, BROWN, BUFFALO, CLARK, CODINGTON, DAY, DEUEL, EDMUNDS, FAULK, GRANT, HAMLIN, HAND, HYDE, KINGSBURY, MCPHERSON, MARSHALL, MOODY, ROBERTS, AND SPINK COUNTIES

LL. **2.0 LB/FT Flanged Channel Post:** 2.0 LB/FT Flanged Channel Post shall be used to replace damaged delineator posts in a guardrail installation area. 2.0 LB/FT Flanged Channel Post will also be the pay item for the 3.5 ft long base post if it is required. The retainer-spacer strap and other miscellaneous hardware required shall be incidental to the contract unit price per foot for 2.0 LB/FT Flanged Channel Post. Delineators themselves will be paid for separately as 4" x 4" White Delineator Reflector.

MM. **4" x 4" White Delineator Reflector:** 4" x 4" White Delineator Reflector shall be used to replace damaged and/or missing delineator heads on existing delineator posts in a guardrail installation area. Any post straightening or realignment of posts shall be incidental to the contract unit price per each for 4" x 4" White Delineator Reflector. 4" x 4" White Delineator Reflector will also be the pay item for delineator heads when installing a new 2.0 LB/FT Flanged Channel Post. A typical installation will require 2 delineator heads. Delineator heads shall be fastened to the post with pop rivets.

9. Traffic Control shall be installed by the Contractor in accordance with the details on Sheets [12](#) thru [14](#) of the Contract. All signs, channelizing devices, and arrow boards shall conform to the requirements of the Manual of Uniform Traffic Control Devices. All costs for furnishing, installing, and maintaining the traffic control shall be incidental to the contract unit prices bid for the various contract items. Separate measurement and payment will not be made.

When work is being performed on two way traffic roadways, flagging shall be furnished by the Contractor in accordance with the standard plate included in this contract. All costs associated with furnishing flagging shall be incidental to the contract unit prices bid for the various contract items. Separate measurement and payment will not be made.

Portable sign supports shall be constructed to yield upon impact to minimize hazards to motorists. The bottom of signs on portable or temporary supports shall not be less than seven feet above the pavement in urban areas and one foot above the pavement in rural areas.

It shall be the responsibility of the Contractor to ensure that all devices meet the applicable NCHRP 350 requirements.

Equipment and vehicles entering or exiting the roadway, traveling on the shoulders or driving lanes at low speeds or working within the right-of-way shall display a flashing amber light visible for a minimum distance of 1/4 mile in all directions.

10. When the Contractor is called in to work at more than one site within an Area, Mobilization will only be paid once. In the event that Mobilization is required in two or more Areas at one time, the Contractor will be paid Mobilization into each one of the specific Areas. The cover sheets show where bridges are located within the Areas. There may be additional locations that have guardrail such as box culverts, large pipe, and steep inslopes which are not indicated on the cover sheets. Long runs of 3 Cable Guardrail exist on several water hazard sites. These include:

SD 25 from MRM 175.5 to MRM 177.8 in Day County
US 212 from MRM 350.6 to MRM 351.7 in Clark County

GUARDRAIL ACCIDENT DAMAGE REPAIR

BEADLE, BROOKINGS, BROWN, BUFFALO, CLARK, CODINGTON, DAY, DEUEL, EDMUNDS, FAULK, GRANT, HAMLIN, HAND, HYDE, KINGSBURY, MCPHERSON, MARSHALL, MOODY, ROBERTS, AND SPINK COUNTIES

11. The Standard Plates included in this contract are provided for information purposes on how the various guardrail items are to be constructed and the materials required to do the work. Plan notes contained on Sheets [4](#) thru [10](#) of this contract shall take precedence over notes contained on the Standard Plates.

GUARDRAIL ACCIDENT DAMAGE REPAIR

BEADLE, BROOKINGS, BROWN, BUFFALO, CLARK, CODINGTON, DAY, DEUEL, EDMUNDS, FAULK, GRANT, HAMLIN, HAND, HYDE, KINGSBURY, MCPHERSON, MARSHALL, MOODY, ROBERTS, AND SPINK COUNTIES

Approved W Beam Guardrail End Terminals

Product Sub-Type:	Product Name:	Manufacturer:
Tangent Terminal	SKT 350	Road System, Inc. Big Spring TX (432) 263-2435 http://www.roadsystems.com
Tangent Terminal	ET-2000 Plus	SYRO, Inc. a Trinity Industries Co. Dallas TX (800) 644-7976 http://www.trinitycp.com
Flared Terminal	Fleat 350	Road System, Inc. Big Spring TX (432) 263-2435 http://www.roadsystems.com
Flared Terminal	SRT-350 (6-Post System)	SYRO, Inc. a Trinity Industries Co. Dallas TX (800) 644-7976 http://www.trinitycp.com

GUARDRAIL ACCIDENT DAMAGE REPAIR

BEADLE, BROOKINGS, BROWN, BUFFALO, CLARK, CODINGTON, DAY, DEUEL, EDMUNDS, FAULK, GRANT, HAMLIN, HAND, HYDE, KINGSBURY, MCPHERSON, MARSHALL, MOODY, ROBERTS, AND SPINK COUNTIES

Posted Speed Prior to Work (M.P.H.)	Spacing of Advance Warning Signs (Feet) (A)	Spacing of Channelizing Devices (Feet) (G)
0 - 30	200	25
35 - 40	350	25
45 - 50	500	50
55	750	50
60 - 65	1000	50

- Flagger
- Channelizing Device

For low-volume traffic situations with short work zones on straight roadways where the flagger is visible to road users approaching from both directions, a single flagger may be used.

The ROAD WORK AHEAD and the END ROAD WORK signs may be omitted for short duration operations (1 hour or less).

For tack and/or flush seal operations, when flaggers are not being used, the FRESH OIL sign (W21-2) shall be displayed in advance of the liquid asphalt areas.

Flashing warning lights and/or flags may be used to call attention to the advance warning signs.

The channelizing devices shall be drums or type II barricades if traffic control must remain overnight or longer. During daylight hours, 42" cones may be used in lieu of drums or type II barricades along the centerline.

2-020
ROAD WORK
END

Channelizing devices are not required along the centerline adjacent to work area when pilot cars are utilized for escorting traffic through the work area.

Channelizing devices and flaggers shall be used at intersecting roads to control intersecting road traffic as required.

The buffer space shall be a sufficient length so that the channelizing devices are visible to approaching traffic.

Warning sign sequence in opposite direction same as below.

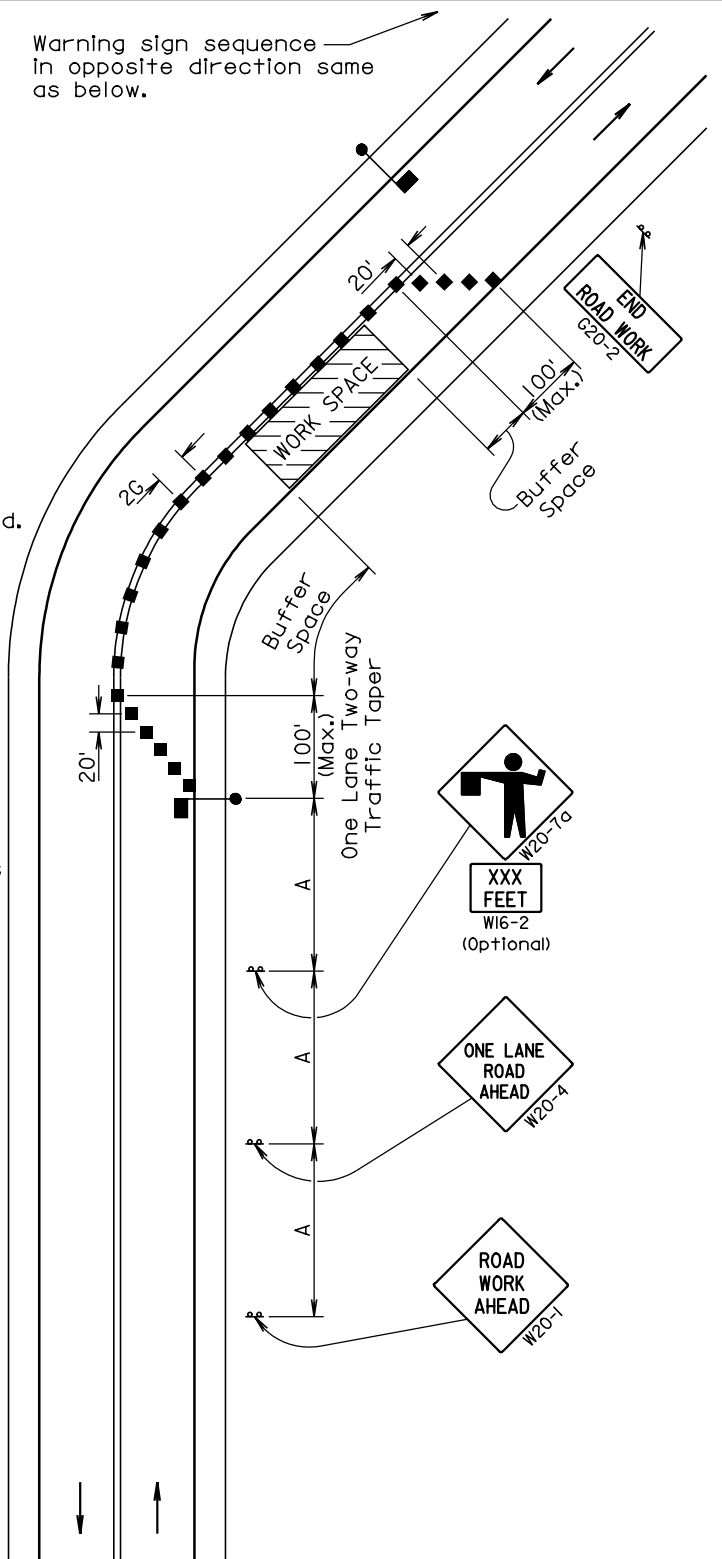

June 26, 2006

Published Date: 2nd Qtr. 2009

**S
D
D
O
T**

**GUIDES FOR TRAFFIC CONTROL DEVICES
LANE CLOSURE WITH FLAGGER PROVIDED**

PLATE NUMBER
634.23

Sheet 1 of 1

GUARDRAIL ACCIDENT DAMAGE REPAIR

BEADLE, BROOKINGS, BROWN, BUFFALO, CLARK, CODINGTON, DAY, DEUEL, EDMUNDS, FAULK, GRANT, HAMLIN, HAND, HYDE, KINGSBURY, MCPHERSON, MARSHALL, MOODY, ROBERTS, AND SPINK COUNTIES

Posted Speed Prior to Work (M.P.H.)	Spacing of Advance Warning Signs (Feet)			Taper Length (Feet) (L)	Spacing of Channelizing Devices (Feet) (G)
	(A)	(B)	(C)		
0 - 30	200			180	25
35 - 40	350			320	25
45 - 50	500			600	50
55	750			660	50
60 - 65	1000			780	50

■ Channelizing Device

Drums or Type II Barricades shall be used if required overnight.

42" cones may be used along centerline

Longitudinal dimensions may be adjusted to fit project conditions such as horizontal curves, vertical curves, and other site restrictions.

Four inch white temporary pavement marking shall be used if traffic control must remain overnight or longer.

April 1, 2008

GUARDRAIL ACCIDENT DAMAGE REPAIR

BEADLE, BROOKINGS, BROWN, BUFFALO, CLARK, CODINGTON, DAY, DEUEL, EDMUNDS, FAULK, GRANT,
HAMLIN, HAND, HYDE, KINGSBURY, MCPHERSON, MARSHALL, MOODY, ROBERTS, AND SPINK COUNTIES

Posted Speed Prior to Work (M.P.H.)	Length of Longitudinal Buffer Space (Feet)
20	35
25	55
30	85
35	120
40	170
45	220
50	280
55	335
60	415
65	485
70	535
75	585

* Shall be used for overnight and long term operations.

This procedure also applies when work is being performed in the lane adjacent to the median on a divided highway. Under these conditions, LEFT LANE CLOSED signs and the corresponding LANE REDUCTION symbol signs shall be used.

END ROAD WORK

(Optional)
G20-2

■ Channelizing Device
Drums or Type II Barricades shall be used if required overnight.
42" cones may be used along centerline

WITHOUT BARRIER

Posted Speed Prior to Work (M.P.H.)	Spacing of Advance Warning Signs (Feet)			Taper Length (Feet) (L)
	(A)	(B)	(C)	
0 - 30	200			180
35 - 40	350			320
45 - 50	500			600
55	750			660
60 - 65	1000			780
	(A)	(B)	(C)	
70 - 75	1000	1600	2600	900

Posted Speed Prior to Work (M.P.H.)	Spacing of Channelizing Devices (Feet) (G)
0 - 30	25
35 - 40	25
45 - 50	50
55	50
60 - 65	50
75	50

Temporary White Edge Line *

Arrow Panel

W4-2

RIGHT LANE CLOSED AHEAD W20-5

ROAD WORK AHEAD W20-1

April 1, 2008

Published Date: 2nd Qtr. 2009

SDDOT
GUIDES FOR TRAFFIC CONTROL DEVICES
LANE CLOSURE WITHOUT BARRIER

PLATE NUMBER
634.64

Sheet 1 of 1

GUARDRAIL ACCIDENT DAMAGE REPAIR

BEADLE, BROOKINGS, BROWN, BUFFALO, CLARK, CODINGTON, DAY, DEUEL, EDMUNDS, FAULK, GRANT, HAMLIN, HAND, HYDE, KINGSBURY, MCPHERSON, MARSHALL, MOODY, ROBERTS, AND SPINK COUNTIES

Published Date: 2nd Qtr. 2009

TODDS

3 CABLE GUARDRAIL

PLATE NUMBER
629.01

Sheet 1 of 6

PLAN

CABLE SPLICE

POST SPACING FOR HORIZONTAL CURVES

ROADWAY ϕ CURVATURE	MAX. POST SPACING
8° and Less	16'
Greater than 8° to 13°	12'

GENERAL NOTES:

Either flanged channel steel posts or S3x5.7 steel I beam posts shall be used, but post type shall be consistent throughout the project. The S3x5.7 Steel I Beam post shall be used for the end posts when the flanged channel steel post is used as line posts.

All costs associated with furnishing and constructing the 3 cable guardrail anchor assembly including the concrete anchor, cable anchor bracket, compensating device, steel turnbuckle cable assembly, and necessary hardware shall be incidental to the contract unit price per Each for "3 Cable Guardrail Anchor Assembly".

All costs associated with furnishing and constructing the 3 cable guardrail including posts, cable, cable splices, and hardware shall be incidental to the contract unit price per Ft for "3 Cable Guardrail".

The following table and criteria shall apply to the arrangement of the Spring Cable End Assemblies (Compensation Devices) and Turnbuckle Cable End Assemblies:

LENGTH OF CABLE RUN	CRITERIA FOR ARRANGEMENT OF THE SPRING CABLE END ASSEMBLIES (COMPENSATION DEVICES) AND TURNBUCKLE CABLE END ASSEMBLIES
To 500'	Use turnbuckle on the approaching traffic end and compensating device on the other end of each individual cable, except in the W Beam to 3 Cable Transition where all compensating devices shall be provided at the bridge ends.
Greater than 500' to 1000'	Use compensating device on each end of each individual cable.
Greater than 1000'	Start new run by interlacing at last parallel post as shown above.

All Compensating Devices shall be attached to the cable anchor bracket when one end of the run is attached to a bridge.

Compensating Devices must have a spring rate of 450 ± 50 Lbs. per inch and shall have a total available travel of 6" minimum.

The cable shall be retensioned after the initial 2 week pretension period in accordance with the following table:

Temperature Range (Deg.)	120 to 110	109 to 100	99 to 90	89 to 80	79 to 70	69 to 60	59 to 50	49 to 40	39 to 30	29 to 20	19 to 10	9 to 0	-1 to -10	-11 to -20
Spring Compression (In.)	1	1 1/4	1 1/2	1 3/4	2	2 1/4	2 1/2	2 3/4	3	3 1/4	3 1/2	3 3/4	4	4 1/4

March 28, 2001

GUARDRAIL ACCIDENT DAMAGE REPAIR

BEADLE, BROOKINGS, BROWN, BUFFALO, CLARK, CODINGTON, DAY, DEUEL, EDMUNDS, FAULK, GRANT,
HAMLIN, HAND, HYDE, KINGSBURY, MCPHERSON, MARSHALL, MOODY, ROBERTS, AND SPINK COUNTIES

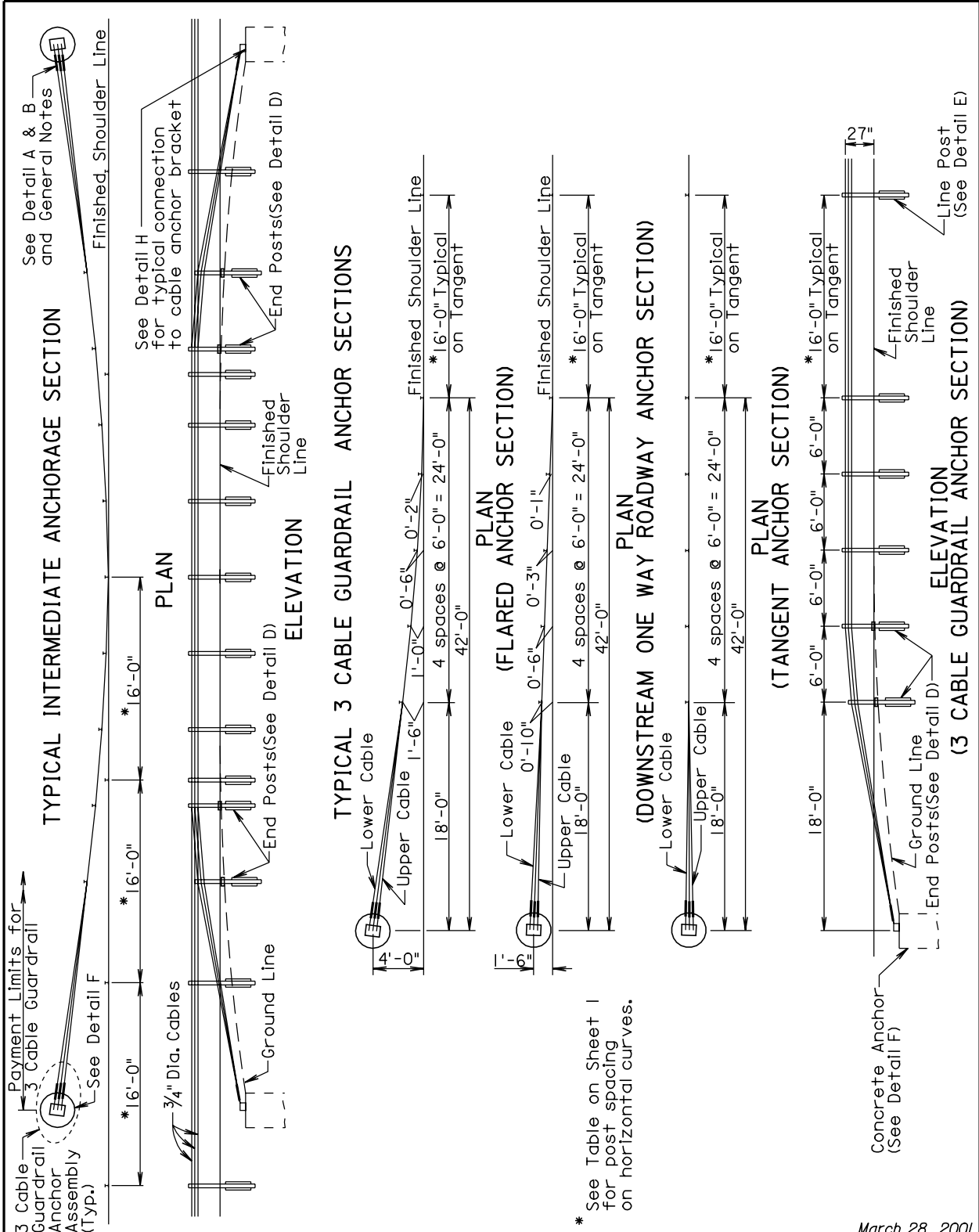

* See Table on Sheet 1 for post spacing on horizontal curves.

March 28, 2001

Published Date: 2nd Qtr. 2009

TODDS

3 CABLE GUARDRAIL

PLATE NUMBER
629.01

Sheet 2 of 6

GUARDRAIL ACCIDENT DAMAGE REPAIR

BEADLE, BROOKINGS, BROWN, BUFFALO, CLARK, CODINGTON, DAY, DEUEL, EDMUNDS, FAULK, GRANT, HAMLIN, HAND, HYDE, KINGSBURY, MCPHERSON, MARSHALL, MOODY, ROBERTS, AND SPINK COUNTIES

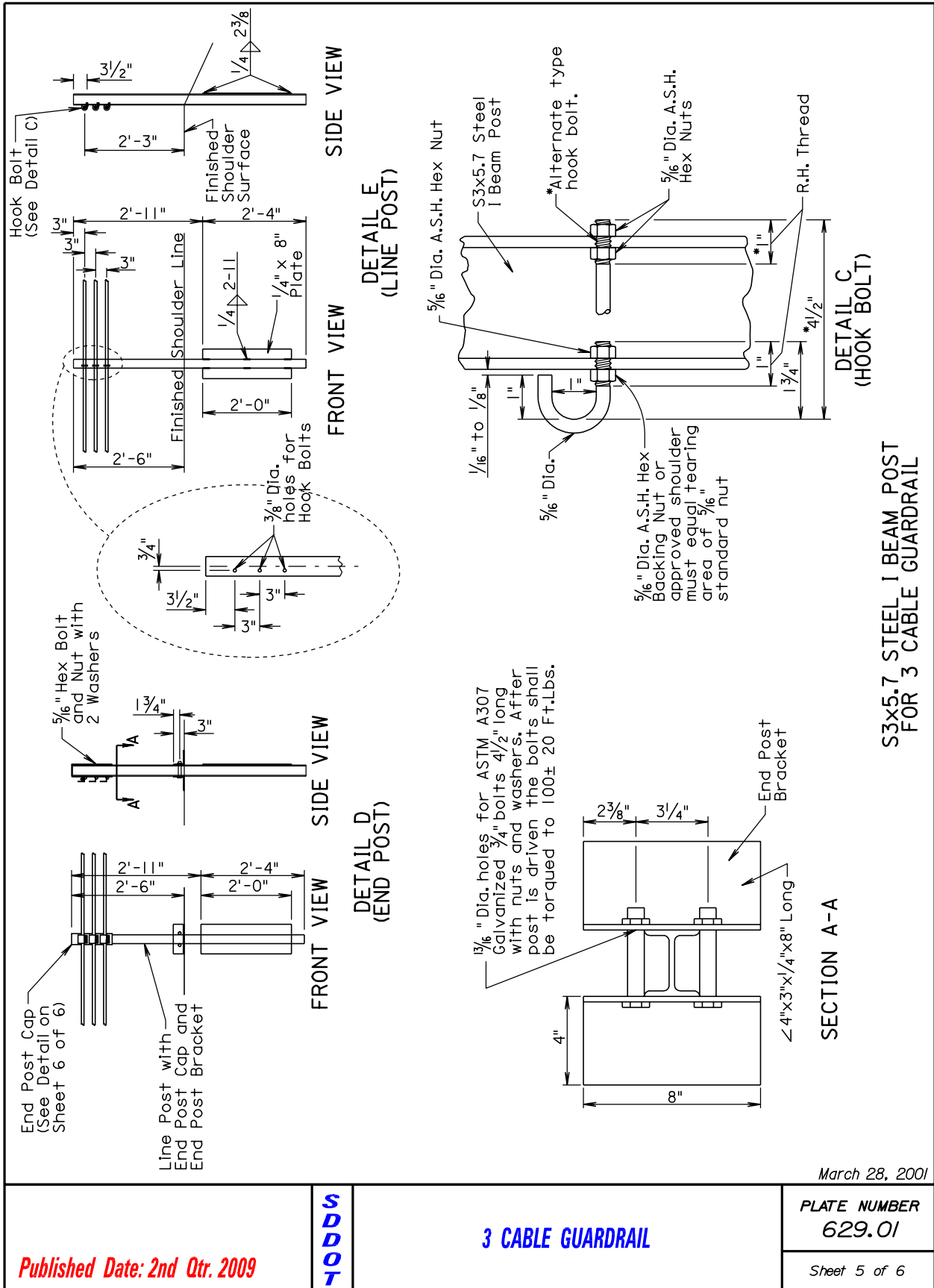

Published Date: 2nd Qtr. 2009

TODDS

3 CABLE GUARDRAIL

PLATE NUMBER
629.01

Sheet 5 of 6

GUARDRAIL ACCIDENT DAMAGE REPAIR

BEADLE, BROOKINGS, BROWN, BUFFALO, CLARK, CODINGTON, DAY, DEUEL, EDMUNDS, FAULK, GRANT, HAMLIN, HAND, HYDE, KINGSBURY, MCPHERSON, MARSHALL, MOODY, ROBERTS, AND SPINK COUNTIES

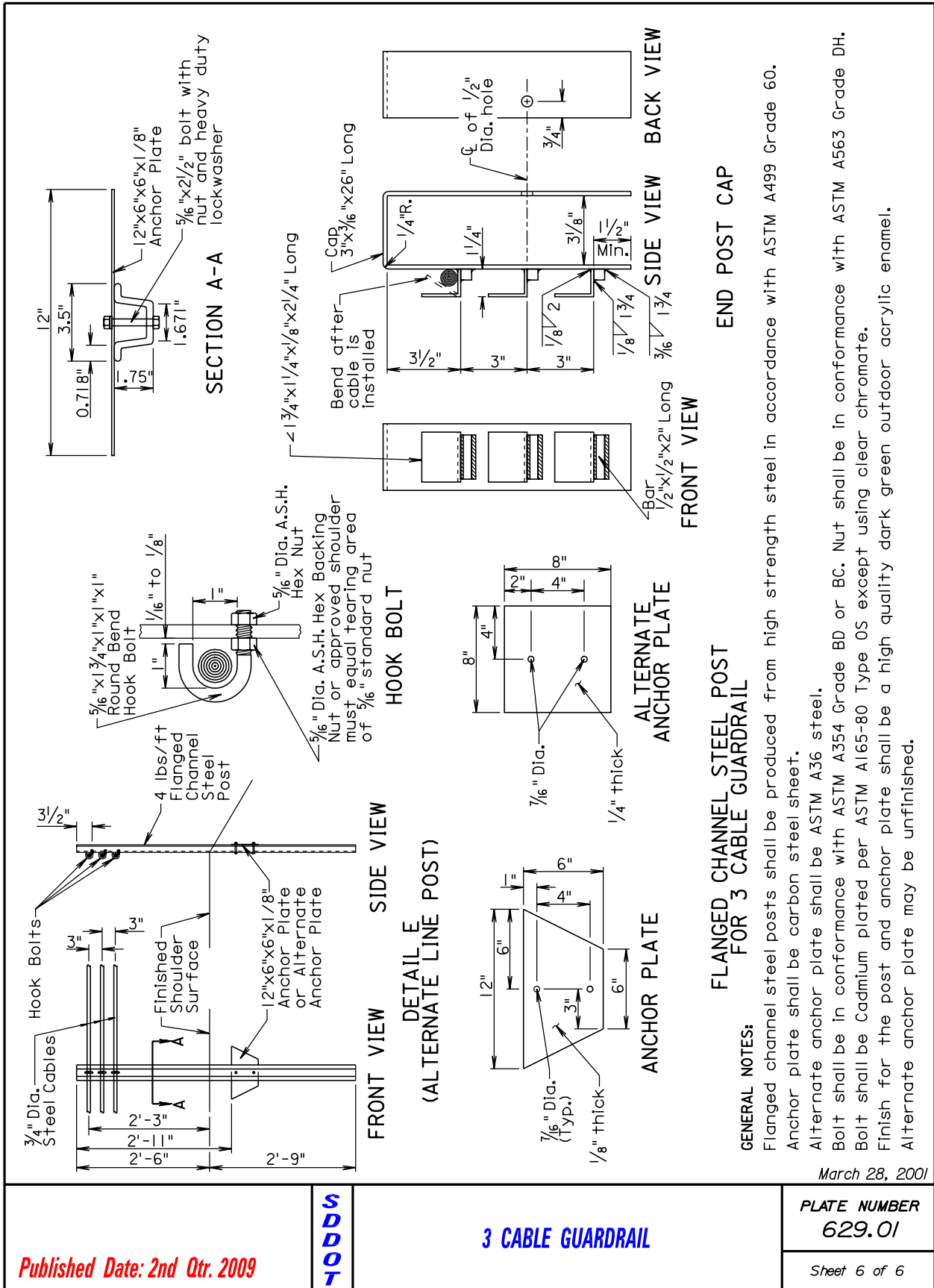

Published Date: 2nd Qtr. 2009

TODDS

3 CABLE GUARDRAIL

PLATE NUMBER
629.01

Sheet 6 of 6

GUARDRAIL ACCIDENT DAMAGE REPAIR

BEADLE, BROOKINGS, BROWN, BUFFALO, CLARK, CODINGTON, DAY, DEUEL, EDMUNDS, FAULK, GRANT, HAMLIN, HAND, HYDE, KINGSBURY, MCPHERSON, MARSHALL, MOODY, ROBERTS, AND SPINK COUNTIES

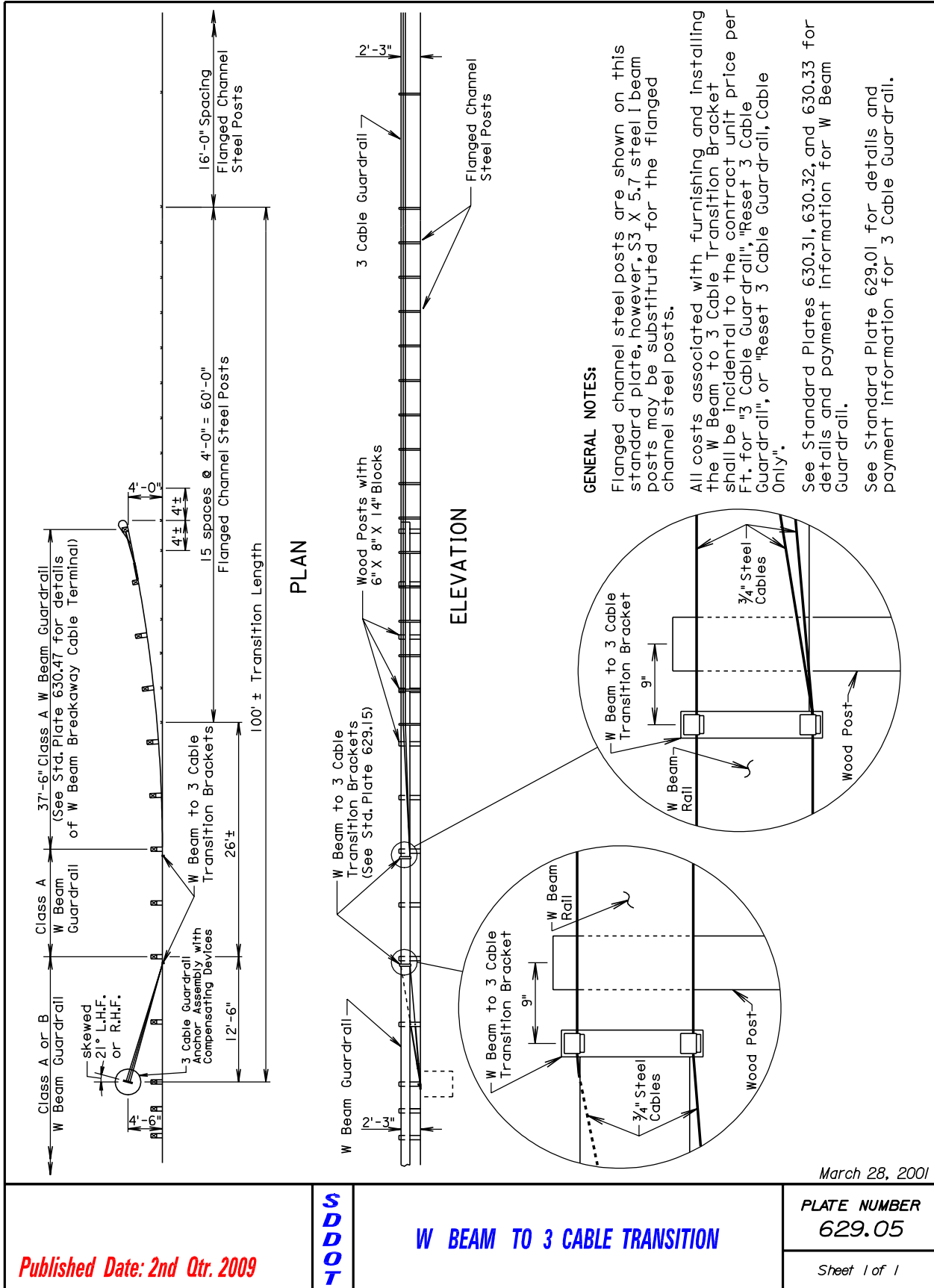

March 28, 2001

Published Date: 2nd Qtr. 2009

TODDS

W BEAM TO 3 CABLE TRANSITION

PLATE NUMBER
629.05

Sheet 1 of 1

GUARDRAIL ACCIDENT DAMAGE REPAIR

BEADLE, BROOKINGS, BROWN, BUFFALO, CLARK, CODINGTON, DAY, DEUEL, EDMUNDS, FAULK, GRANT, HAMLIN, HAND, HYDE, KINGSBURY, MCPHERSON, MARSHALL, MOODY, ROBERTS, AND SPINK COUNTIES

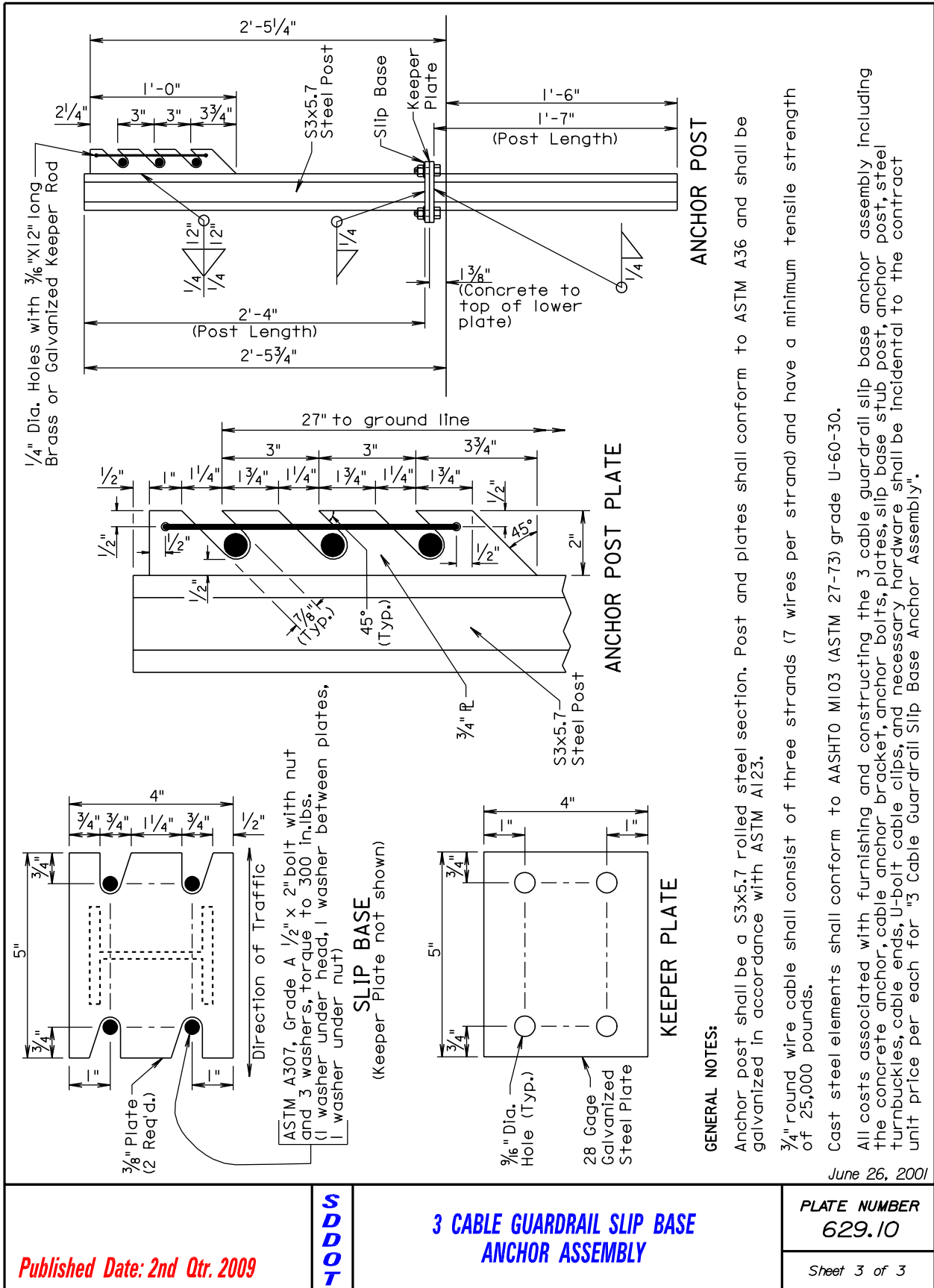

Published Date: 2nd Qtr. 2009

TODDS

**3 CABLE GUARDRAIL SLIP BASE
ANCHOR ASSEMBLY**

PLATE NUMBER
629.10

Sheet 3 of 3

GUARDRAIL ACCIDENT DAMAGE REPAIR

BEADLE, BROOKINGS, BROWN, BUFFALO, CLARK, CODINGTON, DAY, DEUEL, EDMUNDS, FAULK, GRANT,
HAMLIN, HAND, HYDE, KINGSBURY, MCPHERSON, MARSHALL, MOODY, ROBERTS, AND SPINK COUNTIES

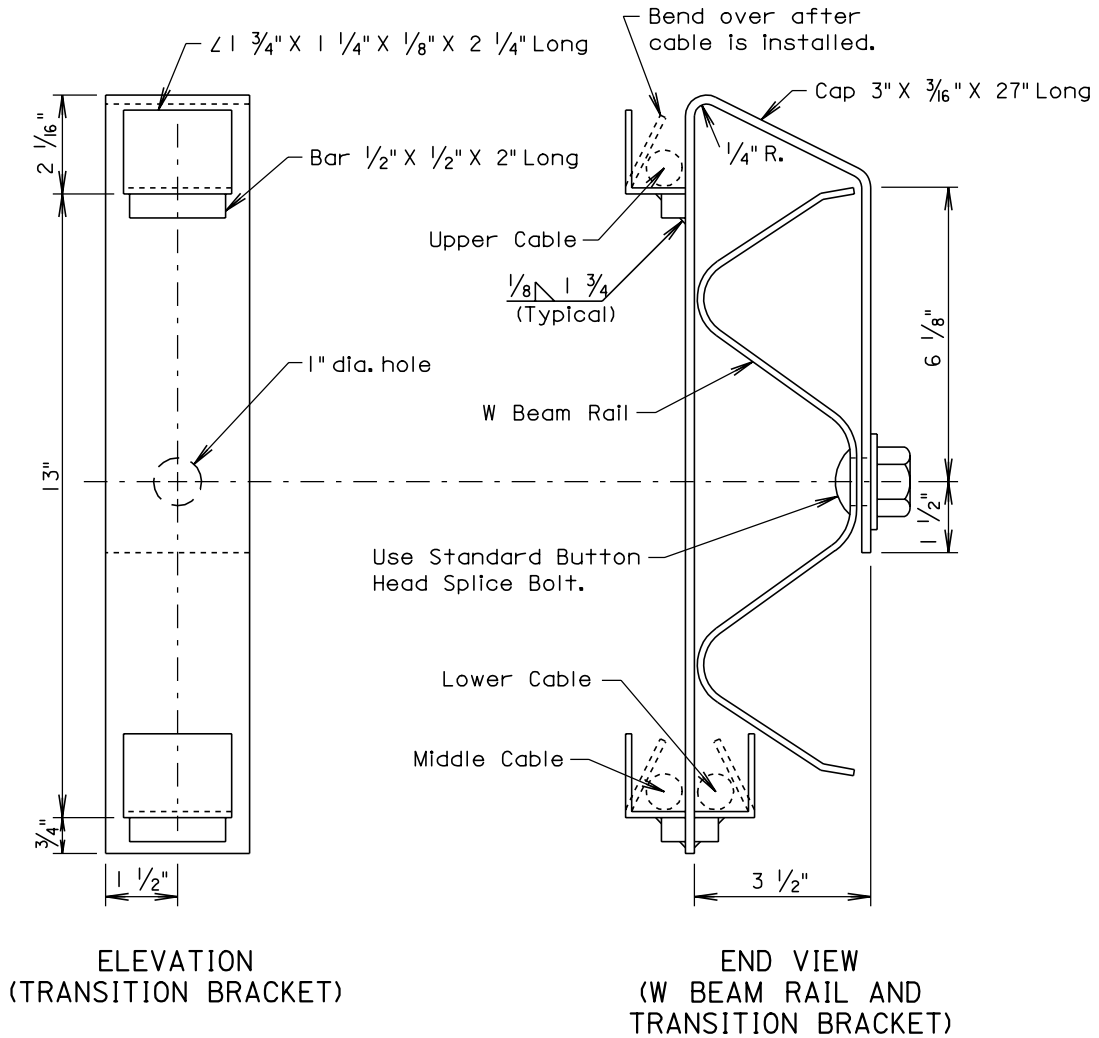

GENERAL NOTES:
Steel used in the fabrication of the bracket shall conform to ASTM A36 and the bracket shall be galvanized after fabrication in accordance with ASTM A123.

March 31, 2000

<p style="color: red; font-weight: bold;">Published Date: 2nd Qtr. 2009</p>	<p style="color: blue; font-weight: bold; font-size: 2em;">S D D O T</p>	<p style="color: blue; font-weight: bold;">W BEAM TO 3 CABLE TRANSITION BRACKET</p>	<p style="font-size: 0.8em;">PLATE NUMBER 629.15</p>
			<p style="font-size: 0.8em;">Sheet 1 of 1</p>

GUARDRAIL ACCIDENT DAMAGE REPAIR

BEADLE, BROOKINGS, BROWN, BUFFALO, CLARK, CODINGTON, DAY, DEUEL, EDMUNDS, FAULK, GRANT,
HAMLIN, HAND, HYDE, KINGSBURY, MCPHERSON, MARSHALL, MOODY, ROBERTS, AND SPINK COUNTIES

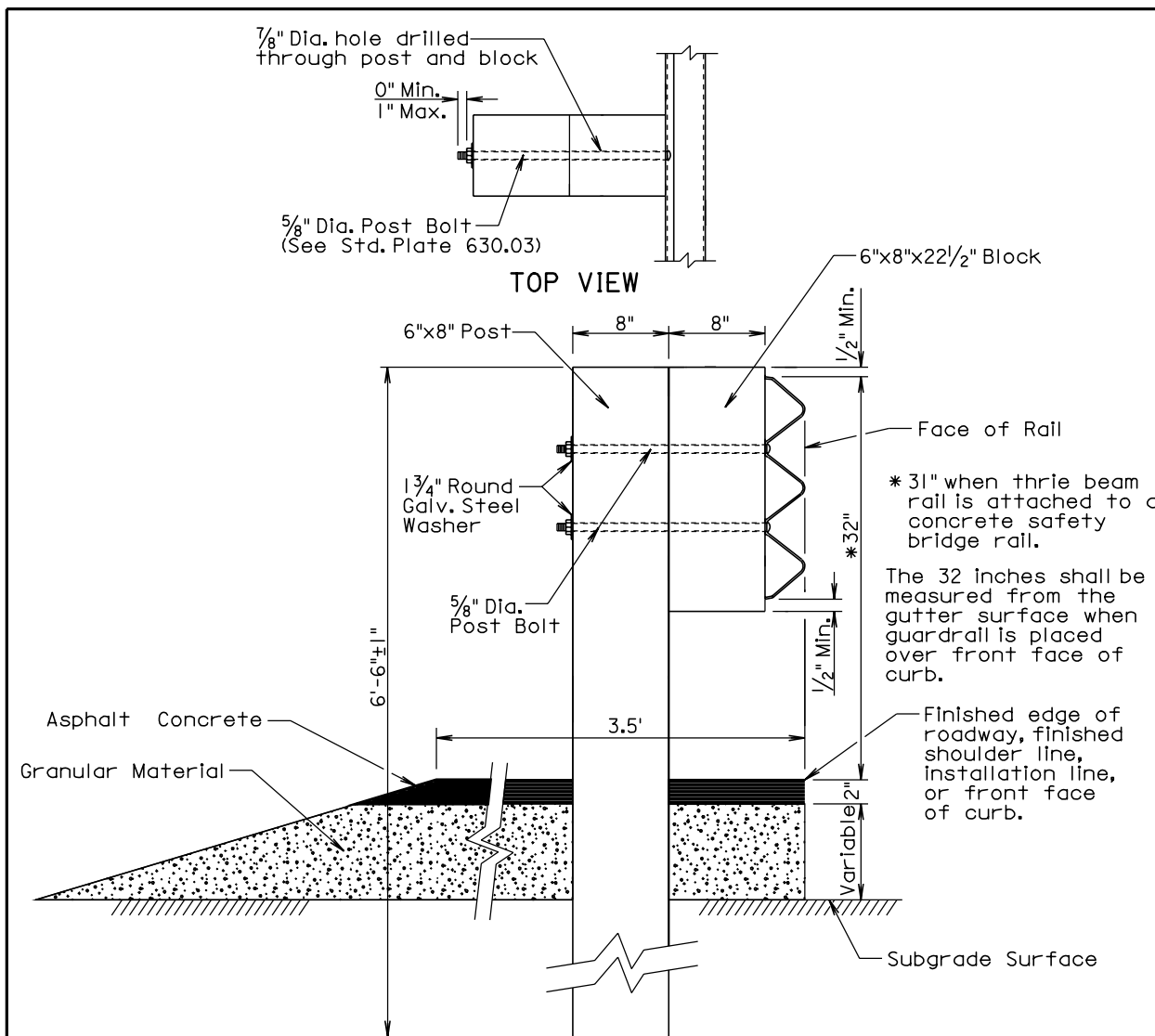

GENERAL NOTES:

Asphalt concrete shall be the same type used elsewhere on the project or shall be as specified in the plans. If asphalt concrete is not specified in the plans, the asphalt concrete shall conform to the SD Standard Specifications for "Asphalt Concrete Composite." For informational purposes, the Rate of Materials for the 3.5' wide section of asphalt concrete as shown above shall be 4.80 Tons per Station.

Granular material shall be the same type used elsewhere on the project or shall be as specified in the plans. If granular material type is not specified in the plans, the material shall conform to the SD Standard Specifications for "Base Course". The granular material shall be placed the same thickness as the mainline surfacing or as specified in the plans.

Surfacing and embankment quantities will be paid for separately and will NOT be incidental to the "Thrie Beam Guardrail" bid item.

The cross slope for the surfacing and subgrade surface shall be as specified in the plans (See Typical Sections and/or Cross Sections).

The top of posts and top of block shall have a true square cut. The top of post and top of block shall be flush.

March 31, 2000

<p style="color: red; font-weight: bold;">Published Date: 2nd Qtr. 2009</p>	<p style="color: blue; font-weight: bold; font-size: 2em;">S D D O T</p>	<p style="color: blue; font-weight: bold; font-size: 1.2em;">THRIE BEAM GUARDRAIL POST INSTALLATION</p>	<p style="font-weight: bold; font-size: 0.8em;">PLATE NUMBER</p> <p style="font-size: 1.2em;">630.01</p>
			<p style="font-size: 0.8em;">Sheet 1 of 1</p>

GUARDRAIL ACCIDENT DAMAGE REPAIR

BEADLE, BROOKINGS, BROWN, BUFFALO, CLARK, CODINGTON, DAY, DEUEL, EDMUNDS, FAULK, GRANT,
HAMLIN, HAND, HYDE, KINGSBURY, MCPHERSON, MARSHALL, MOODY, ROBERTS, AND SPINK COUNTIES

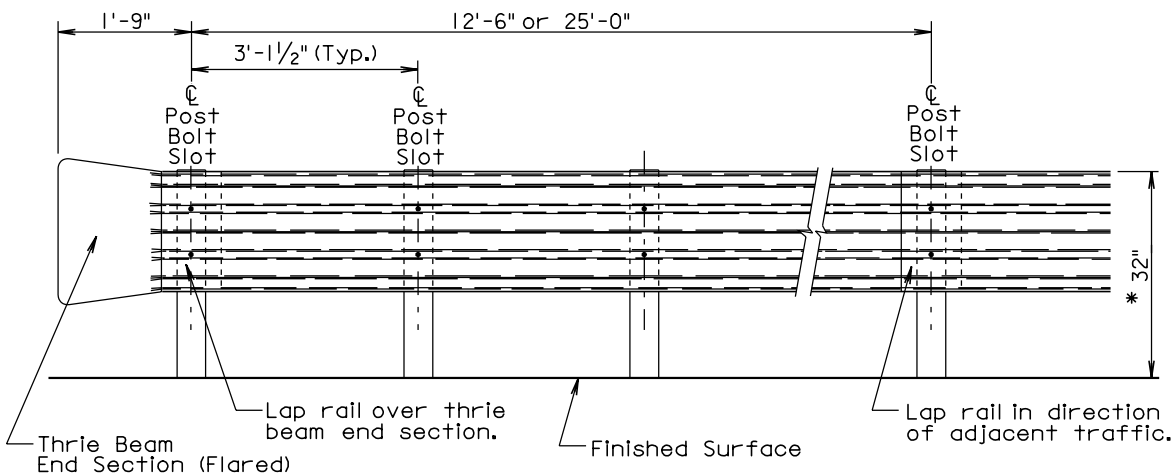

* 31" when thrie beam is attached to a concrete safety bridge rail.

ELEVATION

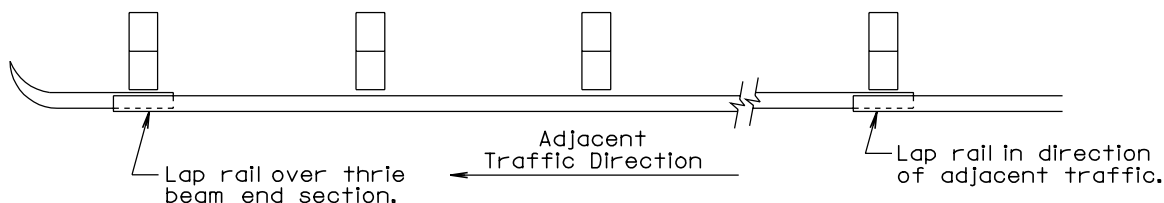

PLAN

THRIE BEAM GUARDRAIL DEFLECTION CRITERIA	
POST SPACING	MAXIMUM DEFLECTION
6'-3"	2'-6"
3'-1/2"	1'-9"

For Informational Purposes Only

GENERAL NOTES:

All thrie beam rail shall be Type 1.

There will be no separate payment for furnishing and installing Thrie Beam End Sections (Flared) and Thrie Beam Terminal Connectors. All costs for the Thrie Beam End Sections (Flared) and Thrie Beam Terminal Connectors shall be incidental to the contract unit price per foot for the respective "Thrie Beam Guardrail" bid item.

Thrie beam rail section lengths may be 12'-6" and/or 25'-0". The combination of section lengths used shall be compatible with the total length of rail per site as shown in the plans.

Thrie Beam End Sections (Flared) shall only be used in a one way traffic situation. See Standard Plate 630.80 for Thrie Beam End Section (Flared) in the Beam Guardrail Trailing End Terminal.

All costs for constructing thrie beam guardrail including labor, equipment, and materials including all posts, blocks, steel beam rail, and hardware shall be incidental to the contract unit price per foot for the respective "Thrie Beam Guardrail" bid item.

Surfacing and embankment quantities will be paid for separately and will NOT be incidental to the "Thrie Beam Guardrail" bid item.

March 28, 2001

Published Date: 2nd Qtr. 2009

**S
D
D
O
T**

THRIE BEAM GUARDRAIL INSTALLATION

**PLATE NUMBER
630.02**

Sheet 1 of 1

GUARDRAIL ACCIDENT DAMAGE REPAIR

BEADLE, BROOKINGS, BROWN, BUFFALO, CLARK, CODINGTON, DAY, DEUEL, EDMUNDS, FAULK, GRANT,
HAMLIN, HAND, HYDE, KINGSBURY, MCPHERSON, MARSHALL, MOODY, ROBERTS, AND SPINK COUNTIES

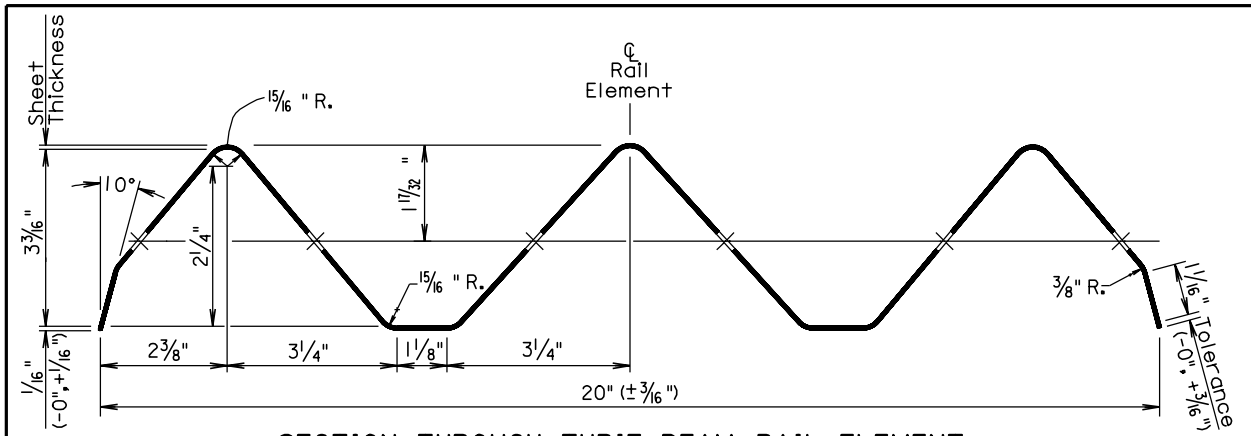

SECTION THROUGH THRIE BEAM RAIL ELEMENT

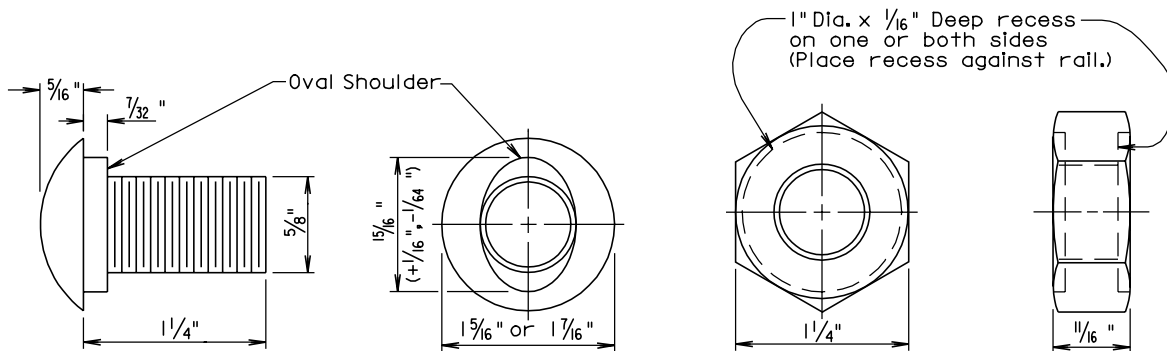

The Post Bolt is similar except the post bolt is 18" long.

SPLICE BOLT
(5/8" BUTTON HEAD BOLT AND RECESS NUT)

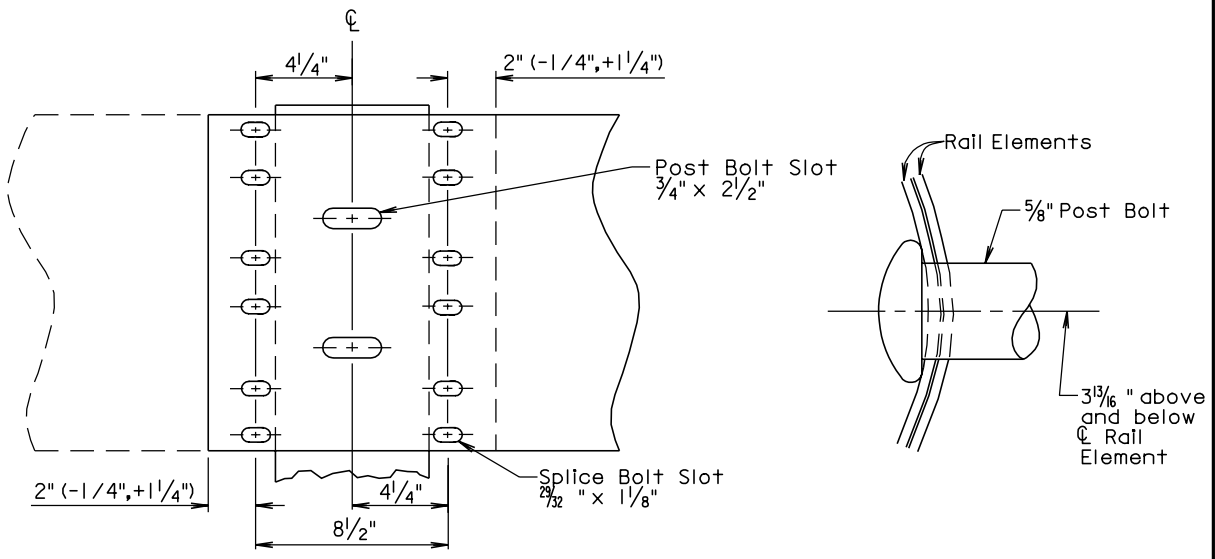

Lap in direction of traffic.

RAIL SPLICE

March 31, 2000

Published Date: 2nd Qtr. 2009

**S
D
D
O
T**

THRIE BEAM RAIL, RAIL SPLICE, AND HARDWARE

PLATE NUMBER
630.03

Sheet 1 of 1

GUARDRAIL ACCIDENT DAMAGE REPAIR

BEADLE, BROOKINGS, BROWN, BUFFALO, CLARK, CODINGTON, DAY, DEUEL, EDMUNDS, FAULK, GRANT,
HAMLIN, HAND, HYDE, KINGSBURY, MCPHERSON, MARSHALL, MOODY, ROBERTS, AND SPINK COUNTIES

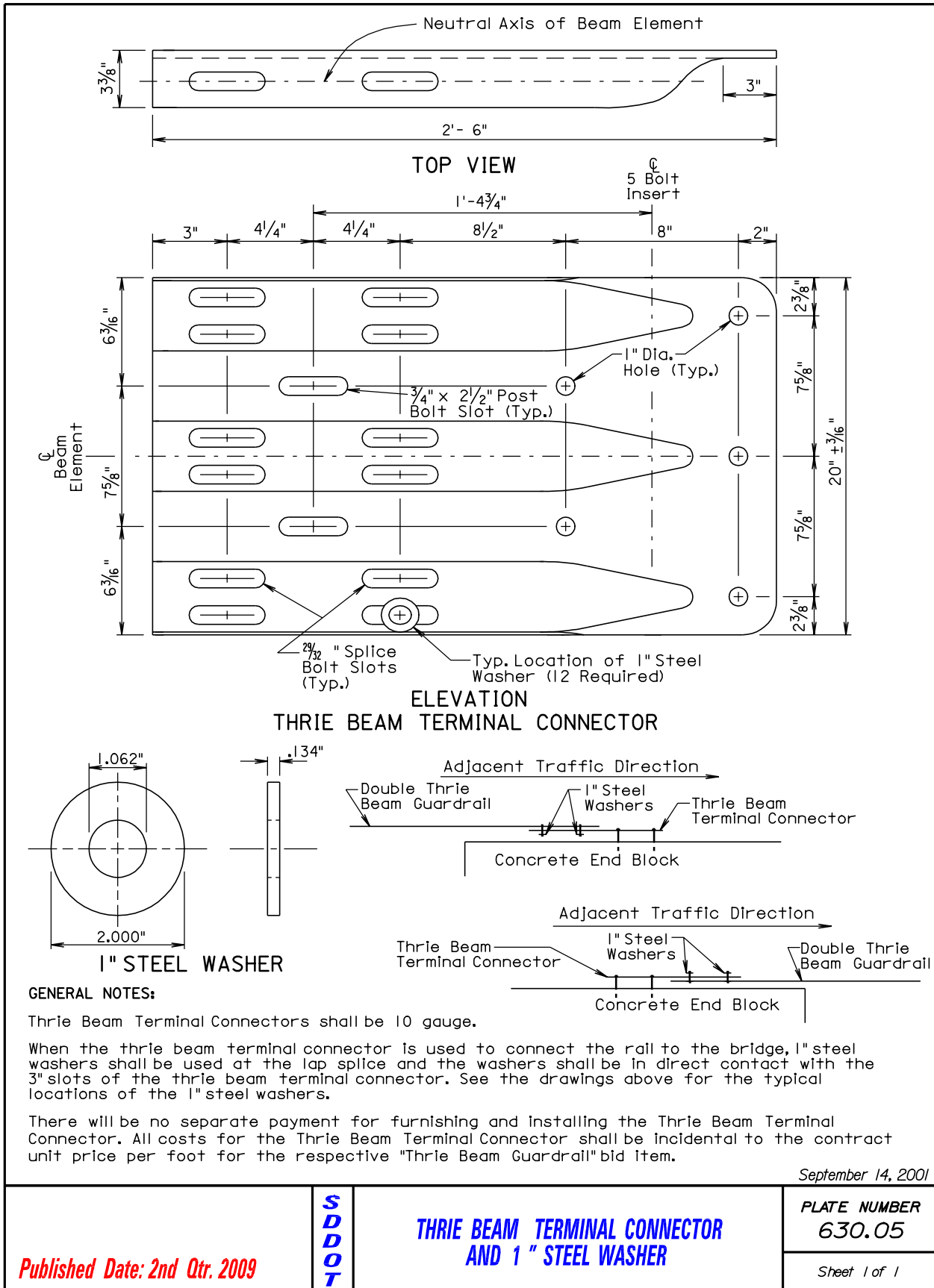

GUARDRAIL ACCIDENT DAMAGE REPAIR

BEADLE, BROOKINGS, BROWN, BUFFALO, CLARK, CODINGTON, DAY, DEUEL, EDMUNDS, FAULK, GRANT,
HAMLIN, HAND, HYDE, KINGSBURY, MCPHERSON, MARSHALL, MOODY, ROBERTS, AND SPINK COUNTIES

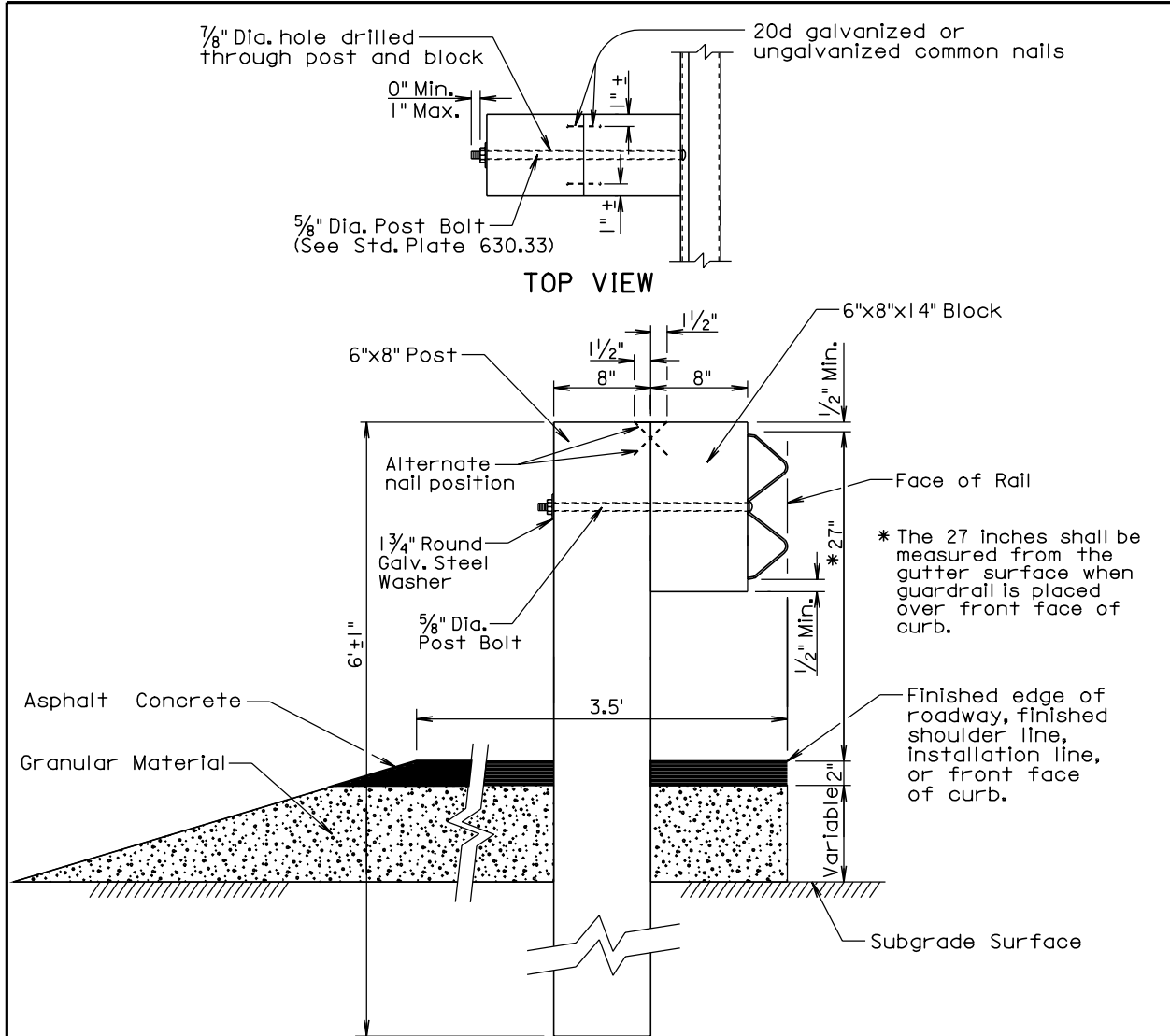

TRANSVERSE SECTION

GENERAL NOTES:

Asphalt concrete shall be the same type used elsewhere on the project or shall be as specified in the plans. If asphalt concrete is not specified in the plans, the asphalt concrete shall conform to the SD Standard Specifications for "Asphalt Concrete Composite." For informational purposes, the Rate of Materials for the 3.5' wide section of asphalt concrete as shown above shall be 4.80 Tons per Station.

Granular material shall be the same type used elsewhere on the project or shall be as specified in the plans. If granular material type is not specified in the plans, the material shall conform to the SD Standard Specifications for "Base Course". The granular material shall be placed the same thickness as the mainline surfacing or as specified in the plans.

Surfacing and embankment quantities will be paid for separately and will NOT be incidental to the "W Beam Guardrail" bid item.

The cross slope for the surfacing and subgrade surface shall be as specified in the plans (See Typical Sections and/or Cross Sections).

The top of posts and top of block shall have a true square cut. The top of post and top of block shall be flush.

September 20, 2000

Published Date: 2nd Qtr. 2009

**S
D
D
O
T**

W BEAM GUARDRAIL POST INSTALLATION

**PLATE NUMBER
630.31**

Sheet 1 of 1

GUARDRAIL ACCIDENT DAMAGE REPAIR

BEADLE, BROOKINGS, BROWN, BUFFALO, CLARK, CODINGTON, DAY, DEUEL, EDMUNDS, FAULK, GRANT,
HAMLIN, HAND, HYDE, KINGSBURY, MCPHERSON, MARSHALL, MOODY, ROBERTS, AND SPINK COUNTIES

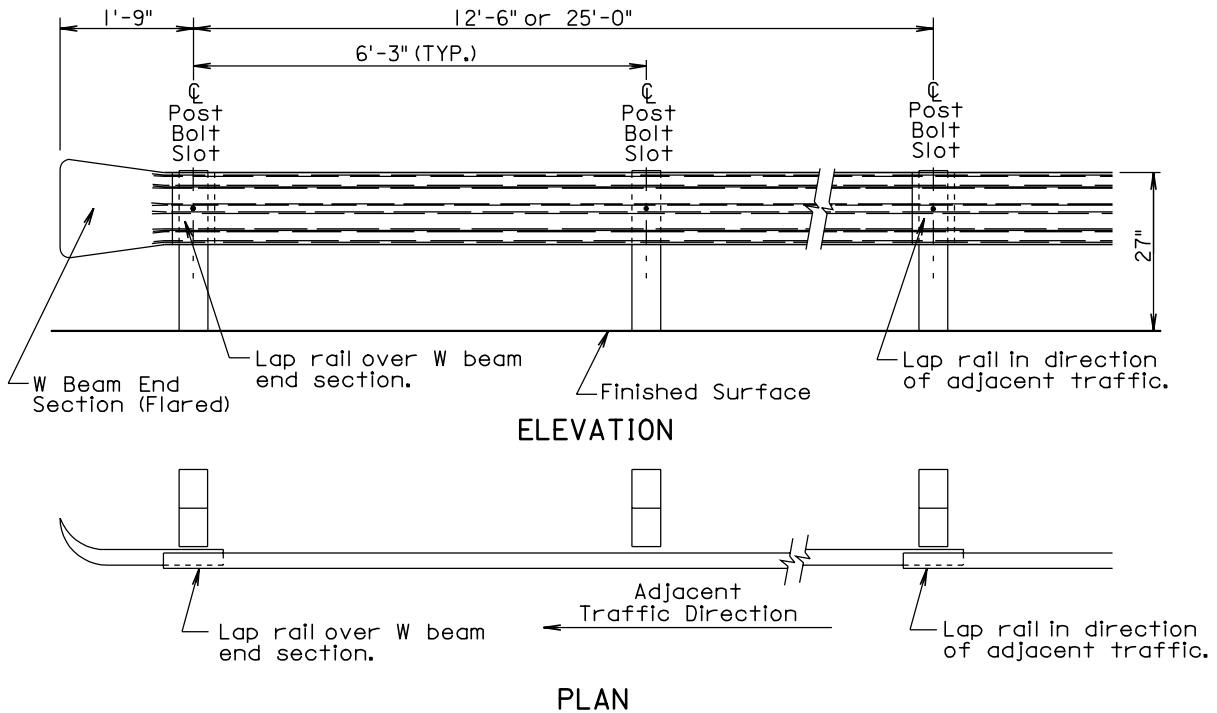

W BEAM GUARDRAIL DEFLECTION CRITERIA	
POST SPACING	MAXIMUM DEFLECTION
6'-3"	3'-3"
3'-1 1/2"	2'-0"

For Informational Purposes Only

GENERAL NOTES:

All W beam rail shall be Type 1.

There will be no separate payment for furnishing and installing W Beam End Sections (Flared) and W Beam Terminal Connectors. All costs for the W Beam End Sections (Flared) and W Beam Terminal Connectors shall be incidental to the contract unit price per foot for the respective "W Beam Guardrail" bid item.

W beam rail section lengths may be 12'-6" and/or 25'-0". The combination of section lengths used shall be compatible with the total length of rail per site as shown in the plans.

W Beam End Sections (Flared) shall only be used in a one way traffic situation. See Standard Plate 630.80 for W Beam End Section (Flared) in the Beam Guardrail Trailing End Terminal.

All costs for constructing W beam guardrail including labor, equipment, and materials including all posts, blocks, steel beam rail, and hardware shall be incidental to the contract unit price per foot for the respective "W Beam Guardrail" bid item.

Surfacing and embankment quantities will be paid for separately and will NOT be incidental to the "W Beam Guardrail" bid item.

March 28, 2001

Published Date: 2nd Qtr. 2009

**S
D
D
O
T**

W BEAM GUARDRAIL INSTALLATION

PLATE NUMBER
630.32

Sheet 1 of 1

GUARDRAIL ACCIDENT DAMAGE REPAIR

BEADLE, BROOKINGS, BROWN, BUFFALO, CLARK, CODINGTON, DAY, DEUEL, EDMUNDS, FAULK, GRANT,
HAMLIN, HAND, HYDE, KINGSBURY, MCPHERSON, MARSHALL, MOODY, ROBERTS, AND SPINK COUNTIES

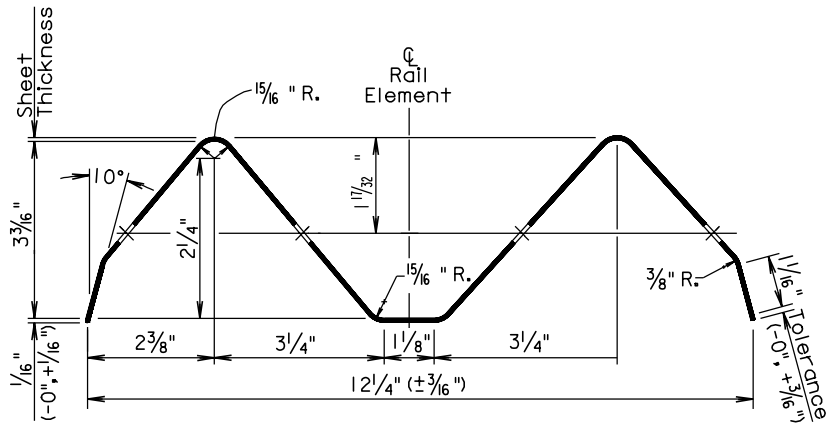

SECTION THROUGH W BEAM RAIL ELEMENT

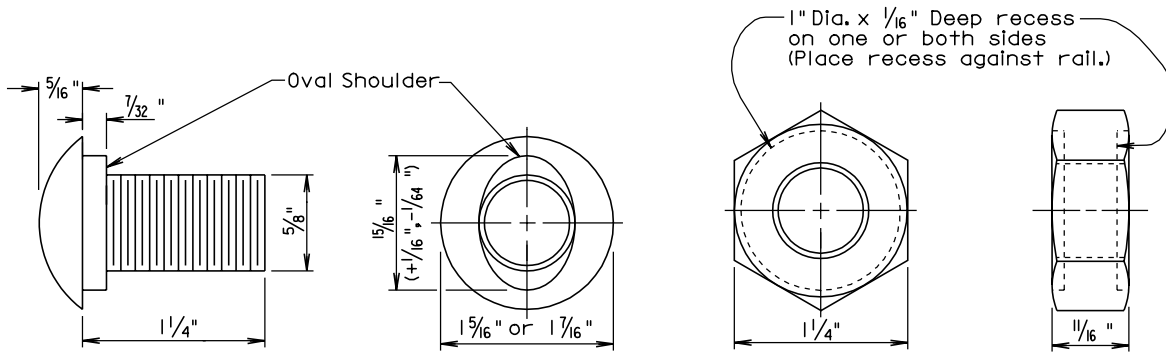

The Post Bolt is similar except the post bolt is 18" long.

**SPLICE BOLT
(5/8" BUTTON HEAD BOLT AND RECESS NUT)**

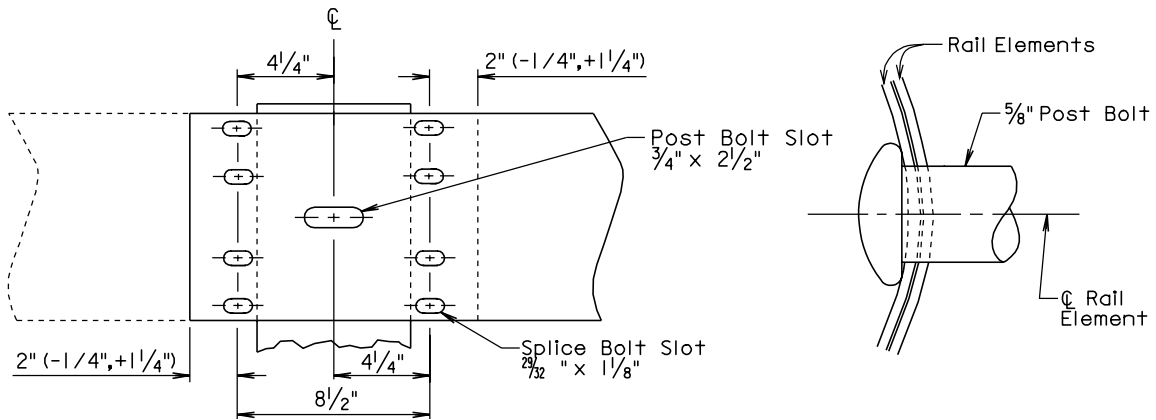

Lap in direction of traffic.
RAIL SPLICE

December 23, 2004

Published Date: 2nd Qtr. 2009

**S
D
D
O
T**

W BEAM RAIL, RAIL SPLICE, AND HARDWARE

**PLATE NUMBER
630.33**

Sheet 1 of 1

GUARDRAIL ACCIDENT DAMAGE REPAIR

BEADLE, BROOKINGS, BROWN, BUFFALO, CLARK, CODINGTON, DAY, DEUEL, EDMUNDS, FAULK, GRANT,
HAMLIN, HAND, HYDE, KINGSBURY, MCPHERSON, MARSHALL, MOODY, ROBERTS, AND SPINK COUNTIES

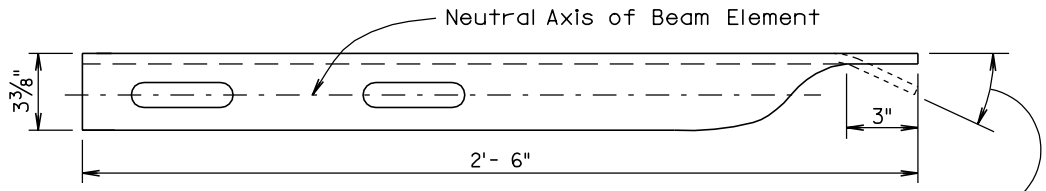

Neutral Axis of Beam Element

3 3/8"

2'- 6"

3"

An extra hole and an approximate 26° bend shall be required only for the Breakaway Cable Terminal. The Modified W Beam Terminal Connector placement detail is shown on Standard Plate 630.47.

TOP VIEW

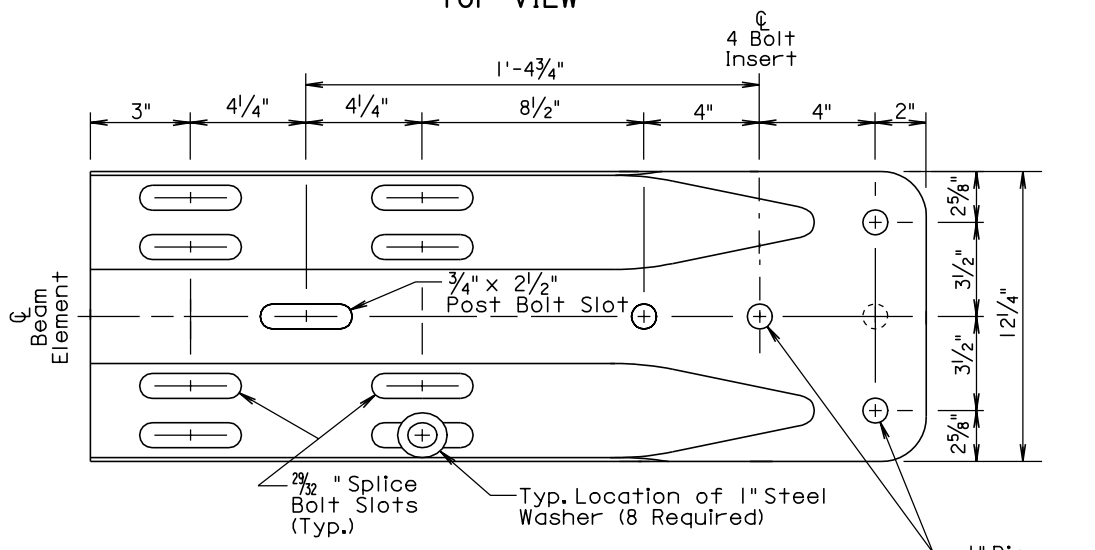

4 Bolt Insert

1'-4 3/4"

3"

4 1/4"

4 1/4"

8 1/2"

4"

4"

2"

3/4" x 2 1/2" Post Bolt Slot

2 9/32" Splice Bolt Slots (Typ.)

Typ. Location of 1" Steel Washer (8 Required)

1" Dia. Hole (Typ.)

2 5/8"

3 1/2"

3 1/2"

12 1/4"

2 5/8"

ELEVATION

W BEAM TERMINAL CONNECTOR

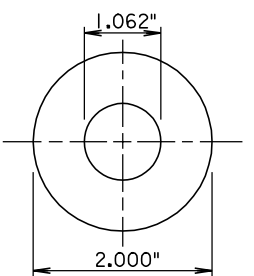

1.062"

2.000"

1" STEEL WASHER

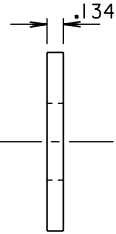

.134"

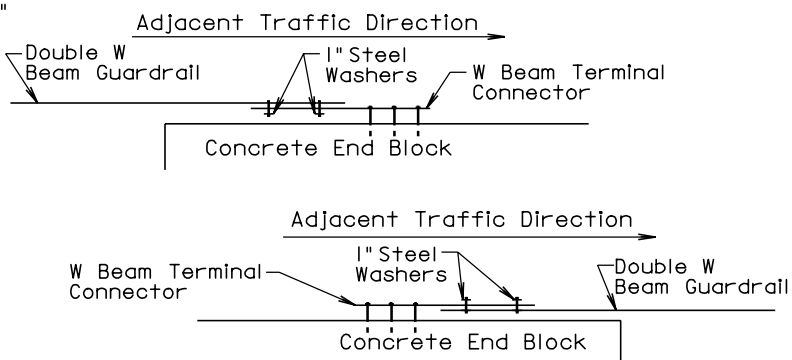

Adjacent Traffic Direction

Double W Beam Guardrail

1" Steel Washers

W Beam Terminal Connector

Concrete End Block

Adjacent Traffic Direction

W Beam Terminal Connector

1" Steel Washers

Double W Beam Guardrail

Concrete End Block

GENERAL NOTES:

W Beam Terminal Connectors shall be 10 gauge.

When the W beam terminal connector is used to connect the rail to the bridge, 1" steel washers shall be used at the lap splice and the washers shall be in direct contact with the 3" slots of the W beam terminal connector. See the drawings above for the typical locations of the 1" steel washers.

There will be no separate payment for furnishing and installing the W Beam Terminal Connector. All costs for the W Beam Terminal Connector shall be incidental to the contract unit price per foot for the respective "W Beam Guardrail" bid item.

September 14, 2001

S D D O T	W BEAM TERMINAL CONNECTOR AND 1" STEEL WASHER	<p>PLATE NUMBER 630.35</p> <p>Sheet 1 of 1</p>
<p><i>Published Date: 2nd Qtr. 2009</i></p>		

GUARDRAIL ACCIDENT DAMAGE REPAIR

BEADLE, BROOKINGS, BROWN, BUFFALO, CLARK, CODINGTON, DAY, DEUEL, EDMUNDS, FAULK, GRANT, HAMLIN, HAND, HYDE, KINGSBURY, MCPHERSON, MARSHALL, MOODY, ROBERTS, AND SPINK COUNTIES

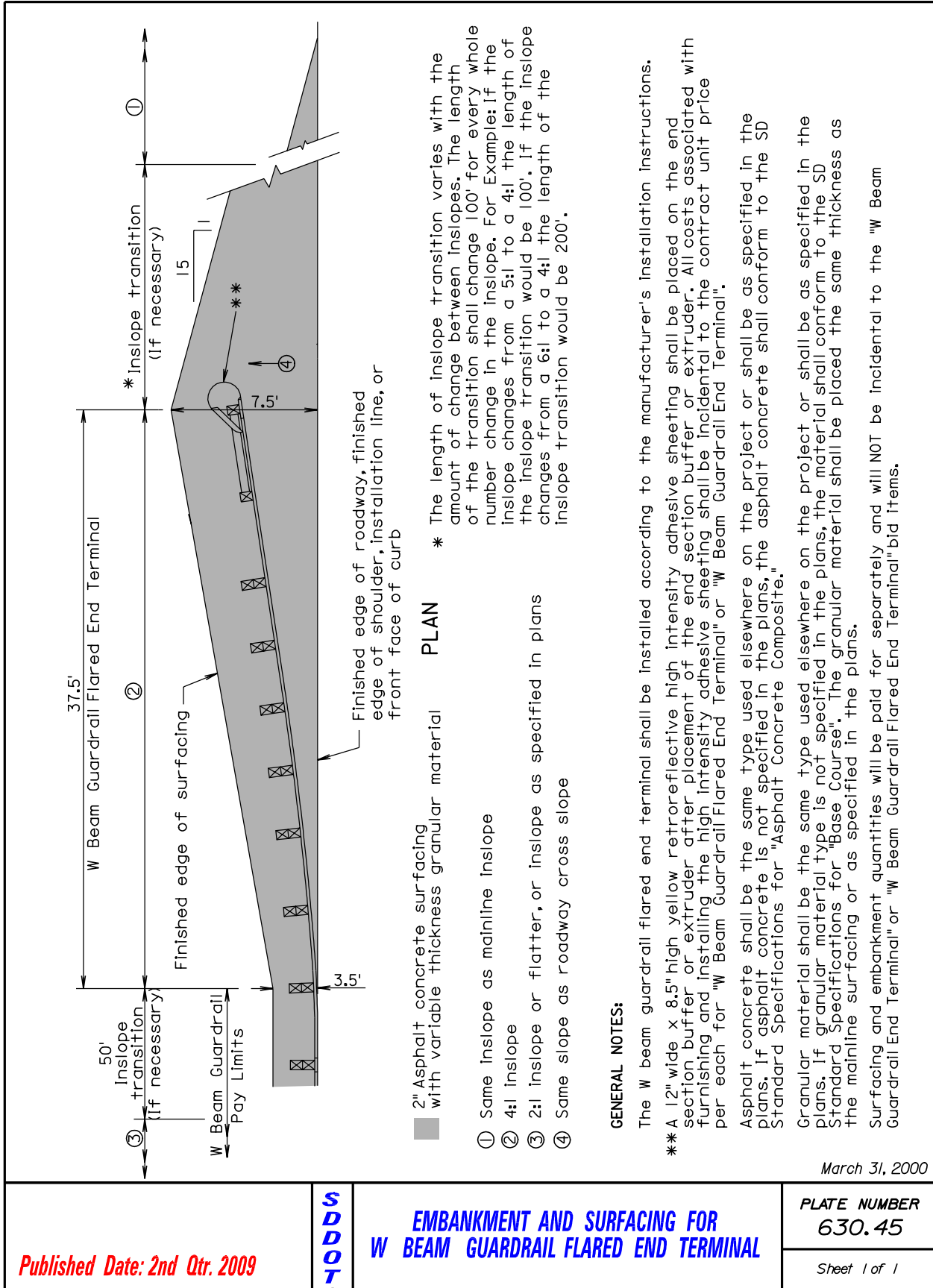

Published Date: 2nd Qtr. 2009

S
D
D
O
T

**EMBANKMENT AND SURFACING FOR
W BEAM GUARDRAIL FLARED END TERMINAL**

PLATE NUMBER
630.45

Sheet 1 of 1

GUARDRAIL ACCIDENT DAMAGE REPAIR

BEADLE, BROOKINGS, BROWN, BUFFALO, CLARK, CODINGTON, DAY, DEUEL, EDMUNDS, FAULK, GRANT, HAMLIN, HAND, HYDE, KINGSBURY, MCPHERSON, MARSHALL, MOODY, ROBERTS, AND SPINK COUNTIES

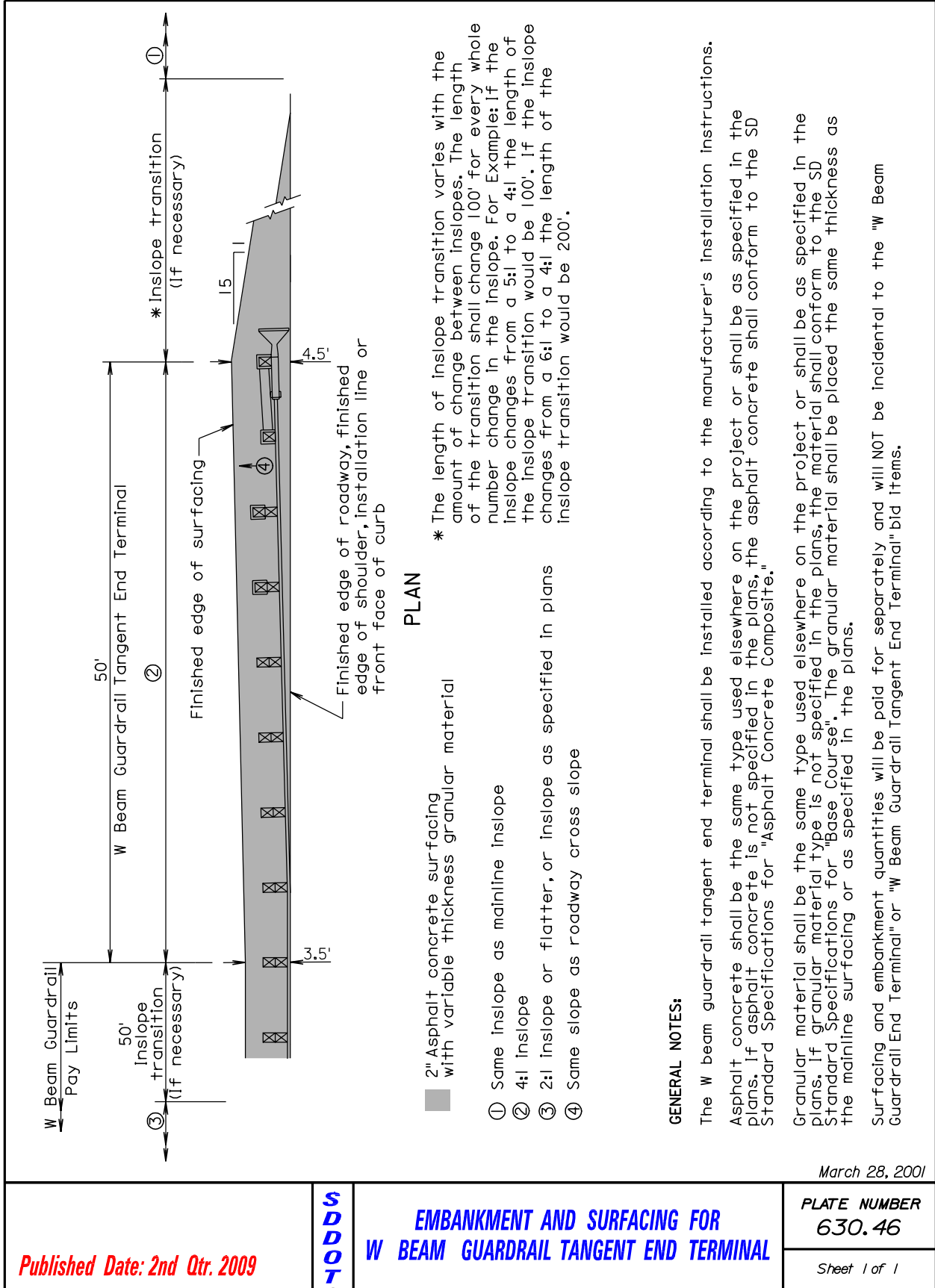

Published Date: 2nd Qtr. 2009

S
D
D
O
T

**EMBANKMENT AND SURFACING FOR
W BEAM GUARDRAIL TANGENT END TERMINAL**

March 28, 2001

PLATE NUMBER
630.46

Sheet 1 of 1

GUARDRAIL ACCIDENT DAMAGE REPAIR

BEADLE, BROOKINGS, BROWN, BUFFALO, CLARK, CODINGTON, DAY, DEUEL, EDMUNDS, FAULK, GRANT, HAMLIN, HAND, HYDE, KINGSBURY, MCPHERSON, MARSHALL, MOODY, ROBERTS, AND SPINK COUNTIES

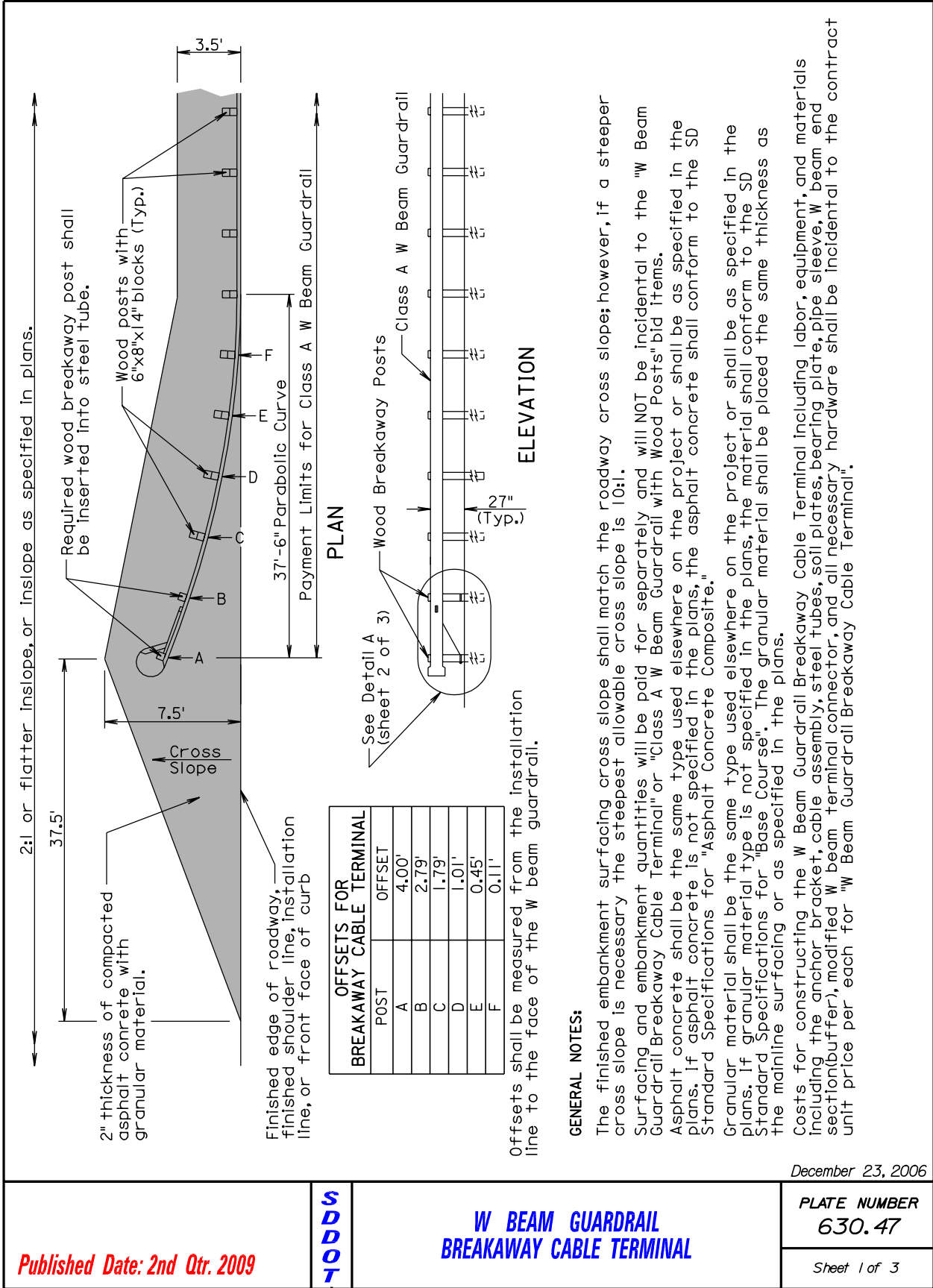

OFFSETS FOR BREAKAWAY CABLE TERMINAL	
POST	OFFSET
A	4.00'
B	2.79'
C	1.79'
D	1.01'
E	0.45'
F	0.11'

Offsets shall be measured from the installation line to the face of the W beam guardrail.

GENERAL NOTES:

The finished embankment surfacing cross slope shall match the roadway cross slope; however, if a steeper cross slope is necessary the steepest allowable cross slope is 10:1.

Surfacing and embankment quantities will be paid for separately and will NOT be incidental to the "W Beam Guardrail Breakaway Cable Terminal" or "Class A W Beam Guardrail with Wood Posts" bid items.

Asphalt concrete shall be the same type used elsewhere on the project or shall be as specified in the plans. If asphalt concrete is not specified in the plans, the asphalt concrete shall conform to the SD Standard Specifications for "Asphalt Concrete Composite."

Granular material shall be the same type used elsewhere on the project or shall be as specified in the plans. If granular material type is not specified in the plans, the material shall conform to the SD Standard Specifications for "Base Course". The granular material shall be placed the same thickness as the mainline surfacing or as specified in the plans.

Costs for constructing the W Beam Guardrail Breakaway Cable Terminal including labor, equipment, and materials including the anchor bracket, cable assembly, steel tubes, soil plates, bearing plate, pipe sleeve, W beam end section (buffer), modified W beam terminal connector, and all necessary hardware shall be incidental to the contract unit price per each for "W Beam Guardrail Breakaway Cable Terminal".

Published Date: 2nd Qtr. 2009

TODDS

**W BEAM GUARDRAIL
BREAKAWAY CABLE TERMINAL**

December 23, 2006

**PLATE NUMBER
630.47**

Sheet 1 of 3

GUARDRAIL ACCIDENT DAMAGE REPAIR

BEADLE, BROOKINGS, BROWN, BUFFALO, CLARK, CODINGTON, DAY, DEUEL, EDMUNDS, FAULK, GRANT,
HAMLIN, HAND, HYDE, KINGSBURY, MCPHERSON, MARSHALL, MOODY, ROBERTS, AND SPINK COUNTIES

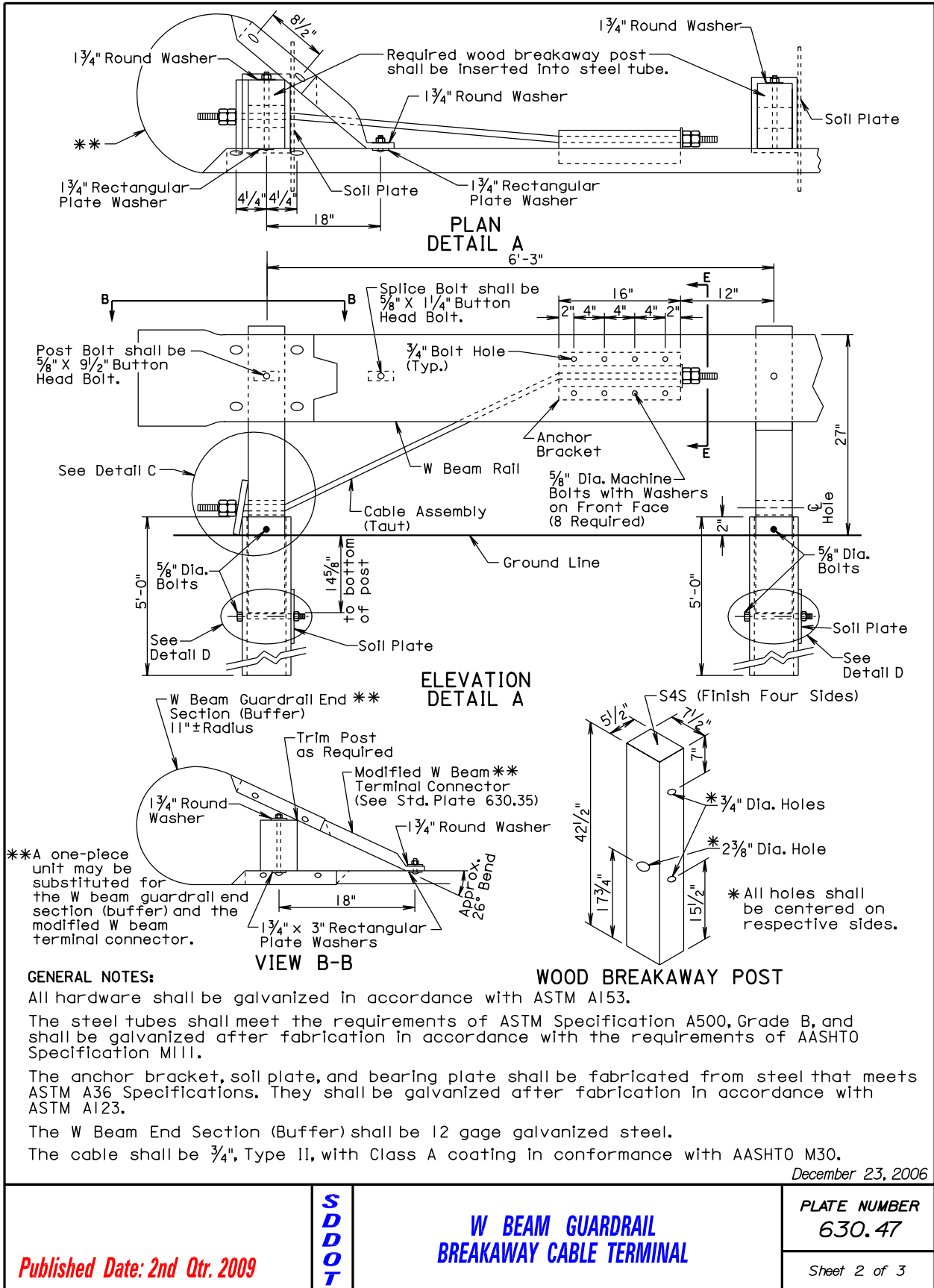

GUARDRAIL ACCIDENT DAMAGE REPAIR

BEADLE, BROOKINGS, BROWN, BUFFALO, CLARK, CODINGTON, DAY, DEUEL, EDMUNDS, FAULK, GRANT, HAMLIN, HAND, HYDE, KINGSBURY, MCPHERSON, MARSHALL, MOODY, ROBERTS, AND SPINK COUNTIES

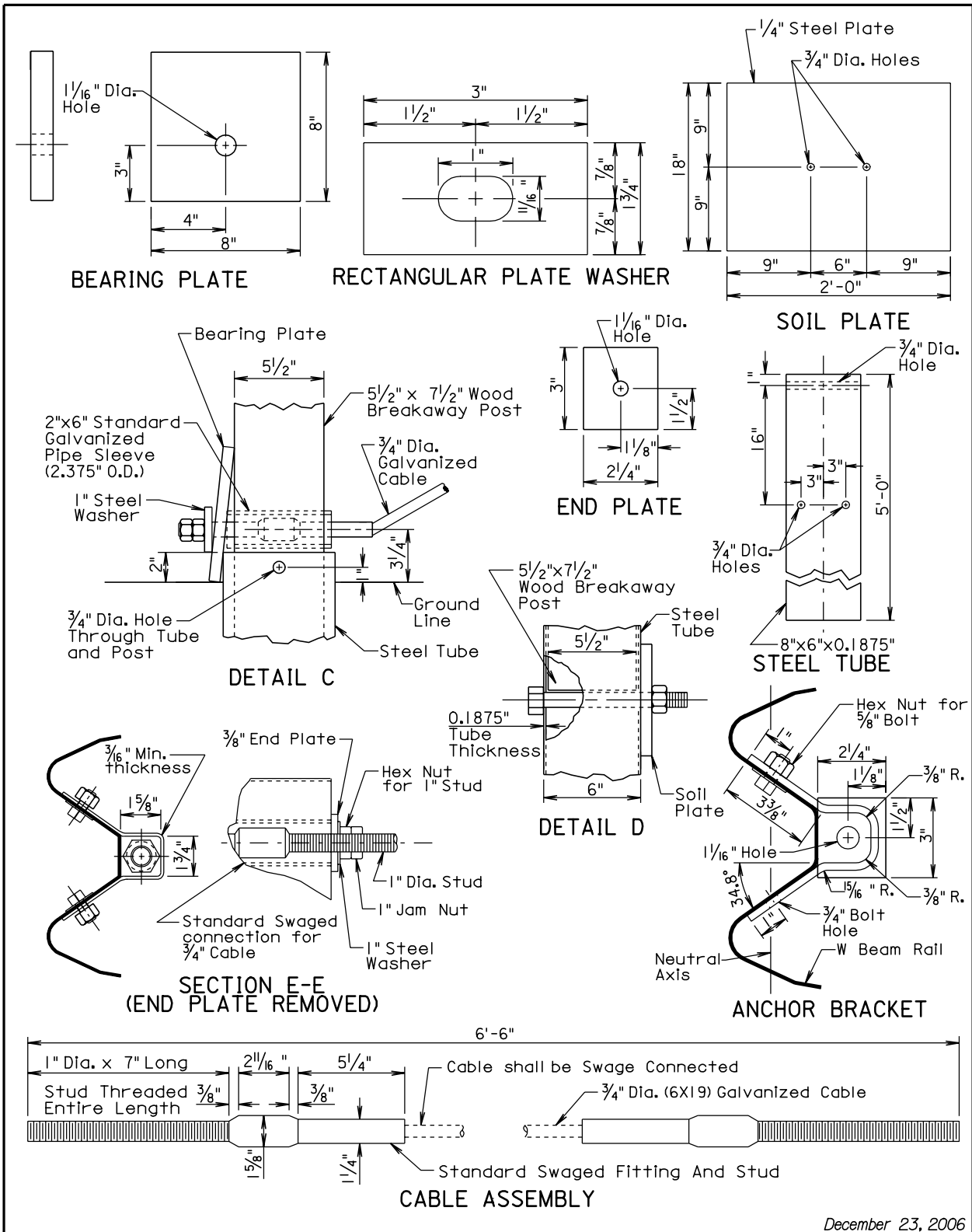

December 23, 2006

Published Date: 2nd Qtr. 2009

SDDOT

**W BEAM GUARDRAIL
BREAKAWAY CABLE TERMINAL**

PLATE NUMBER
630.47

Sheet 3 of 3

GUARDRAIL ACCIDENT DAMAGE REPAIR

BEADLE, BROOKINGS, BROWN, BUFFALO, CLARK, CODINGTON, DAY, DEUEL, EDMUNDS, FAULK, GRANT,
HAMLIN, HAND, HYDE, KINGSBURY, MCPHERSON, MARSHALL, MOODY, ROBERTS, AND SPINK COUNTIES

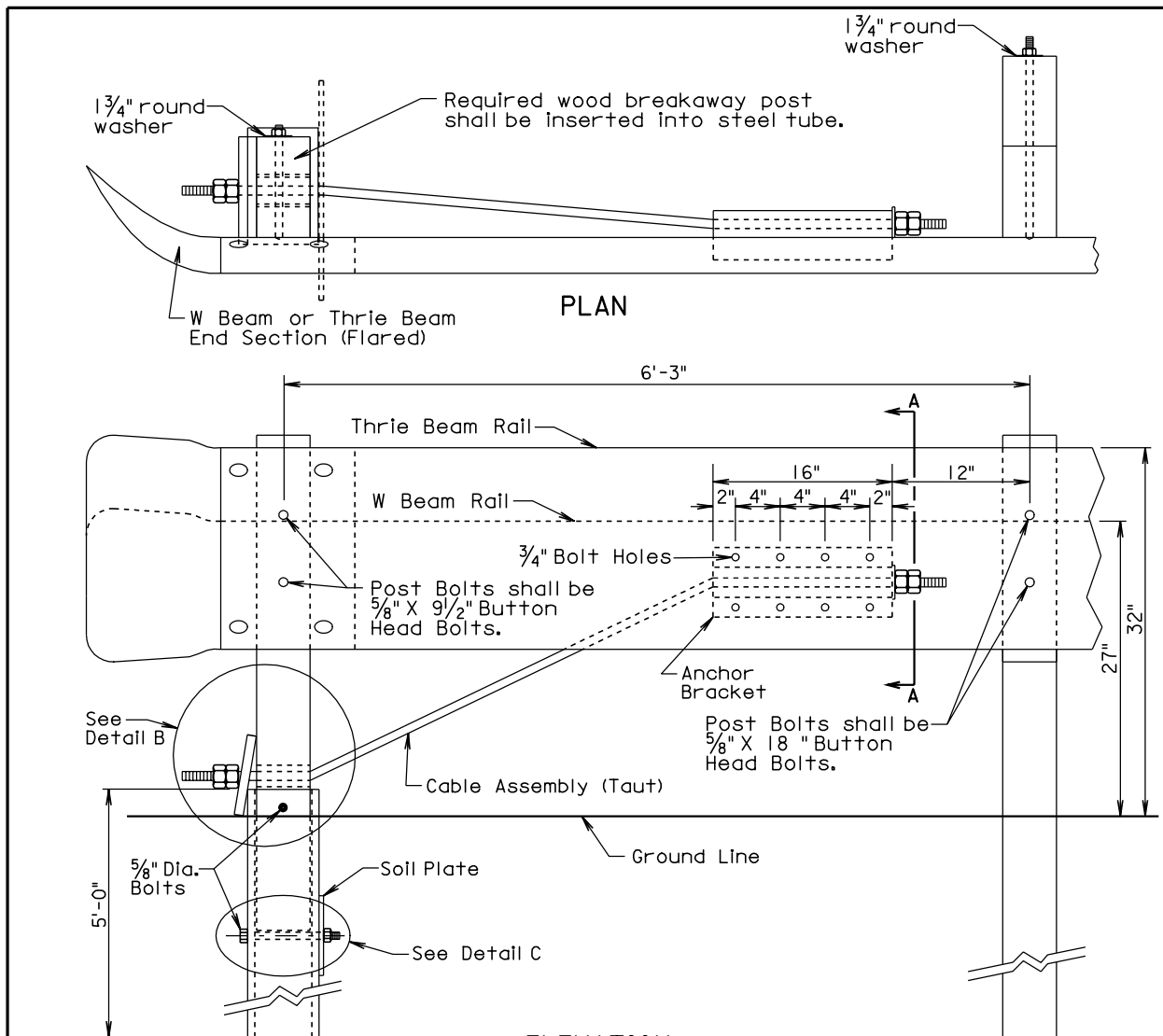

GENERAL NOTES:

- All hardware shall be galvanized in accordance with ASTM A153.
- The cable shall be 3/4", Type II, with Class A coating in conformance with AASHTO M30.
- The steel tube shall meet the requirements of ASTM Specification A500, Grade B, and shall be galvanized after fabrication in accordance with the requirements of AASHTO Specification M111.
- The anchor bracket, soil plate, and bearing plate shall be fabricated from steel that meets ASTM A36 Specifications. They shall be galvanized after fabrication in accordance with ASTM A123.
- Costs for constructing the beam guardrail trailing end terminal and furnishing the anchor bracket, cable assembly, steel tube, soil plate, bearing plate, pipe sleeve, wood breakaway post, and all hardware necessary to attach anchor bracket, cable assembly, steel tube, soil plate, bearing plate, pipe sleeve, and wood breakaway post shall be incidental to the contract unit price per each for "Beam Guardrail Trailing End Terminal".
- Costs for the thrie beam or W beam guardrail and the thrie beam or W beam end sections (Flared) shall be incidental to the contract unit price per foot for the respective "Thrie Beam Guardrail" or "W Beam Guardrail" bid items.

March 31, 2000

<p style="color: red; font-weight: bold;">Published Date: 2nd Qtr. 2009</p>	<p style="color: blue; font-weight: bold; font-size: 2em;">S D D O T</p>	<p style="color: blue; font-weight: bold;">BEAM GUARDRAIL TRAILING END TERMINAL</p>	<p style="font-weight: bold;">PLATE NUMBER</p> <p style="font-size: 1.2em;">630.80</p>
			<p style="font-size: 0.8em;">Sheet 1 of 2</p>

GUARDRAIL ACCIDENT DAMAGE REPAIR

BEADLE, BROOKINGS, BROWN, BUFFALO, CLARK, CODINGTON, DAY, DEUEL, EDMUNDS, FAULK, GRANT, HAMLIN, HAND, HYDE, KINGSBURY, MCPHERSON, MARSHALL, MOODY, ROBERTS, AND SPINK COUNTIES

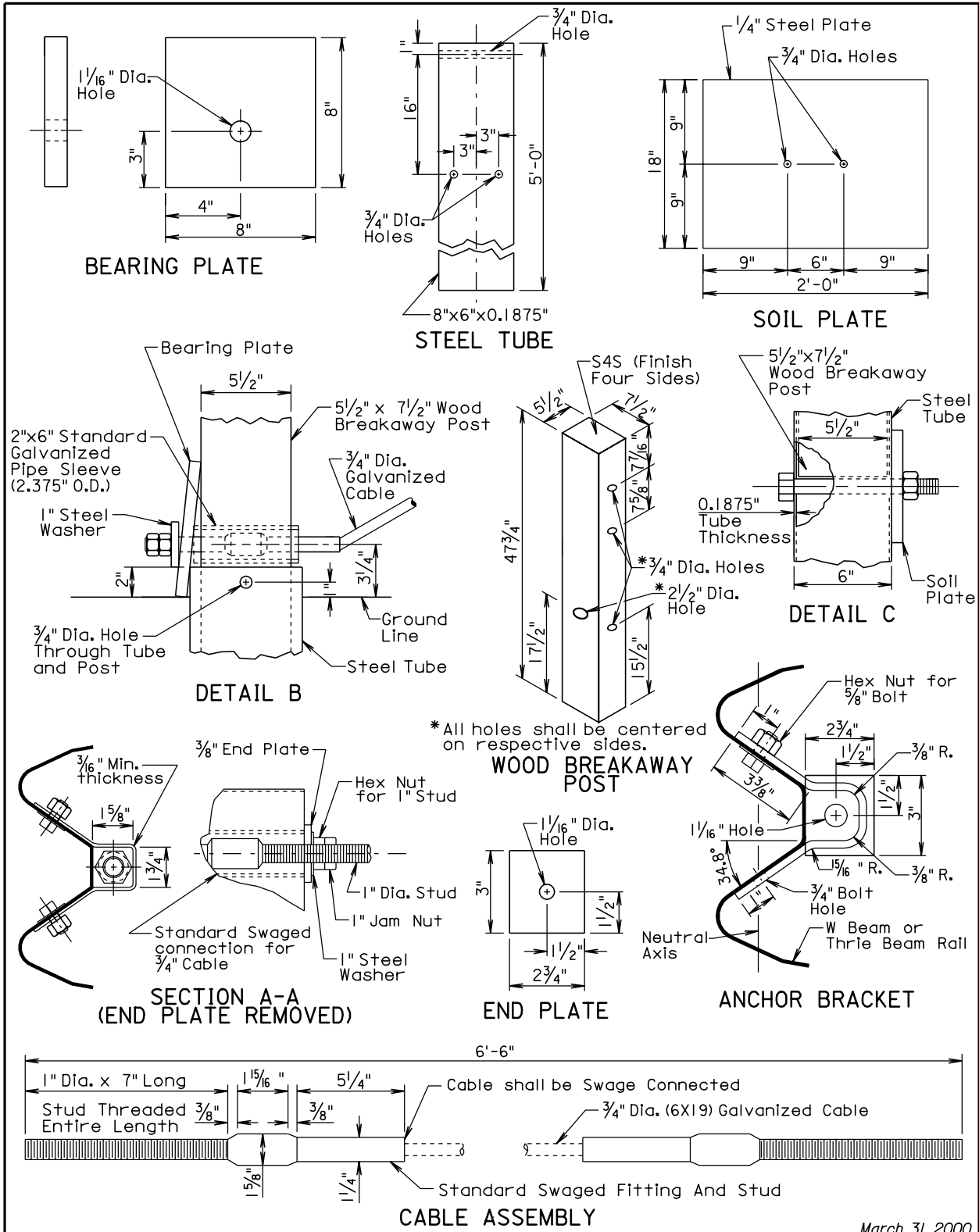

March 31, 2000

<p style="color: red; font-weight: bold;">Published Date: 2nd Qtr. 2009</p>	<p style="color: blue; font-weight: bold; font-size: 2em;">S D D O T</p>	<p style="color: blue; font-weight: bold;">BEAM GUARDRAIL TRAILING END TERMINAL</p>	<p style="font-weight: bold;">PLATE NUMBER 630.80</p>
			<p>Sheet 2 of 2</p>

GUARDRAIL ACCIDENT DAMAGE REPAIR

BEADLE, BROOKINGS, BROWN, BUFFALO, CLARK, CODINGTON, DAY, DEUEL, EDMUNDS, FAULK, GRANT,
HAMLIN, HAND, HYDE, KINGSBURY, MCPHERSON, MARSHALL, MOODY, ROBERTS, AND SPINK COUNTIES

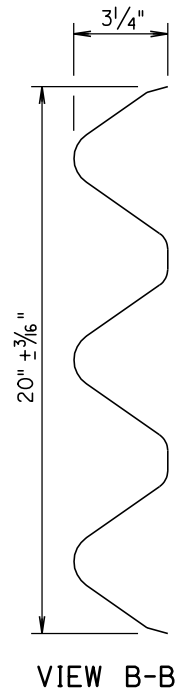
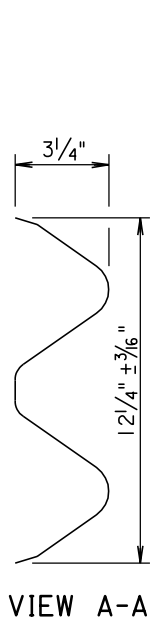
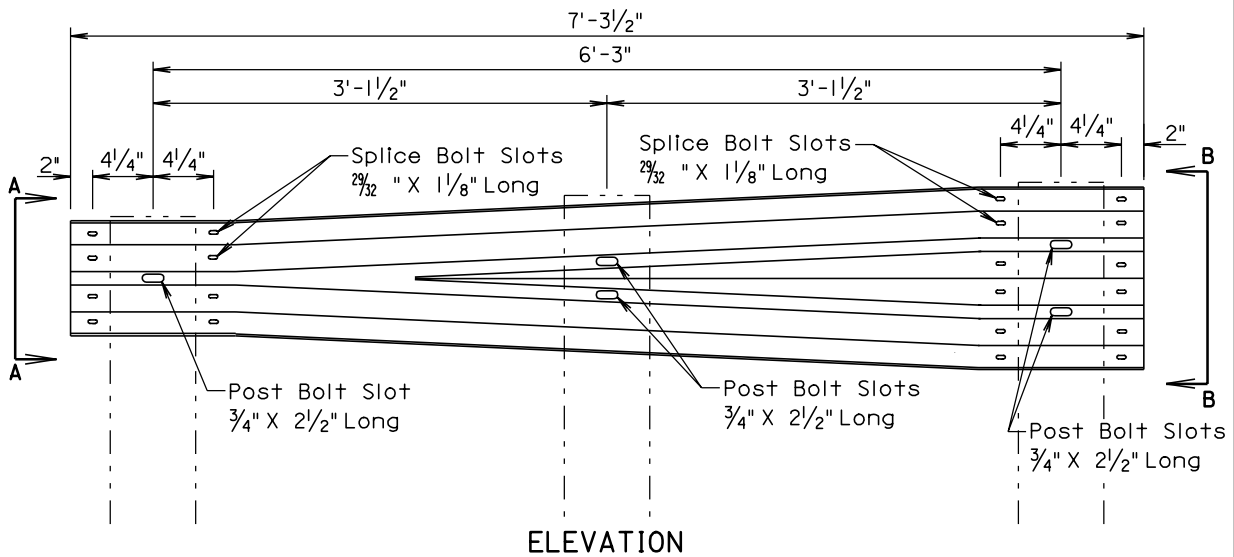

GENERAL NOTE:

All costs for constructing the W Beam to Thrie Beam Guardrail Transition including labor, equipment, and materials including two posts, two blocks, W beam to thrie beam transition section, and hardware shall be incidental to the contract unit price per each for "W Beam to Thrie Beam Guardrail Transition".

March 31, 2000

Published Date: 2nd Qtr. 2009

**S
D
D
O
T**

**W BEAM TO THRIE BEAM GUARDRAIL
TRANSITION SECTION**

**PLATE NUMBER
630.82**

Sheet 1 of 1

GUARDRAIL ACCIDENT DAMAGE REPAIR

BEADLE, BROOKINGS, BROWN, BUFFALO, CLARK, CODINGTON, DAY, DEUEL, EDMUNDS, FAULK, GRANT,
HAMLIN, HAND, HYDE, KINGSBURY, MCPHERSON, MARSHALL, MOODY, ROBERTS, AND SPINK COUNTIES

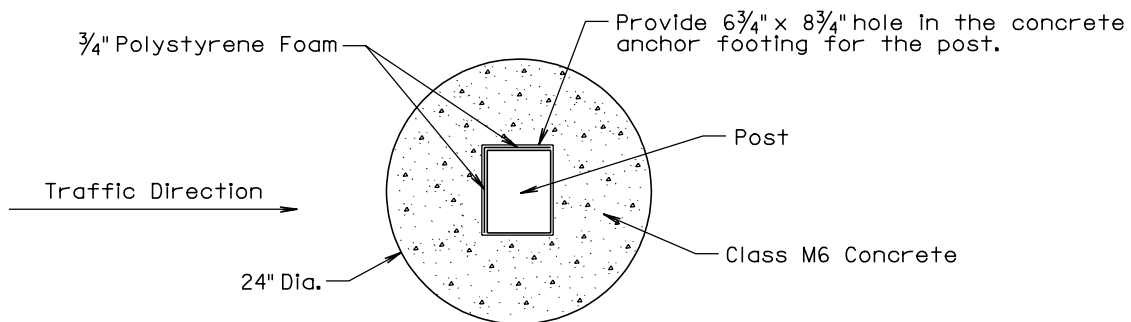

**PLAN
(PREFERRED 24" DIA. ROUND
CONCRETE ANCHOR FOOTING)**

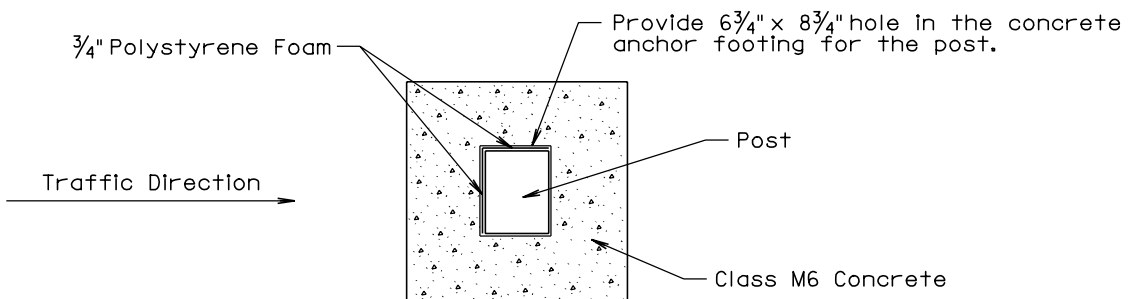

**PLAN
(20" x 20" SQUARE
CONCRETE ANCHOR FOOTING)**

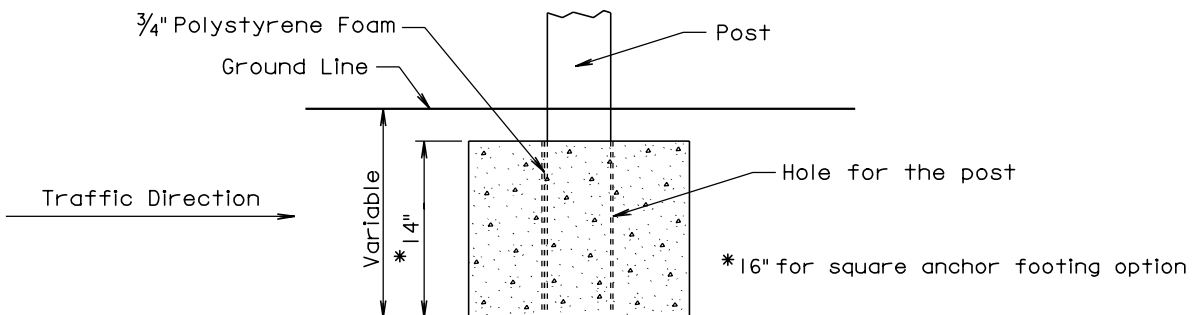

ELEVATION

GENERAL NOTES:

In areas where the required guardrail wood post depth is not obtainable, shorter posts may be used and shall be anchored in concrete in accordance with the details shown on this standard plate.

A 20" x 20" square concrete anchor footing may be used in lieu of the 24" diameter round anchor footing.

Forms for the concrete anchor footing hole is not required.

Concrete for the concrete anchor footing shall be Class M6.

Three quarter inch polystyrene foam shall be attached to two sides of the posts. See details above for placement position of the polystyrene foam.

There will be no separate payment for furnishing and installing the concrete anchor footing for short guardrail post. All costs for concrete anchor footings shall be incidental to the contract unit price per foot for the respective "Thrie Beam or W Beam Guardrail" bid item.

March 31, 2000

<p style="color: red; font-weight: bold;">Published Date: 2nd Qtr. 2009</p>	<p style="font-weight: bold; color: blue;">S D D O T</p>	<p style="font-weight: bold; color: blue;">CONCRETE ANCHOR FOOTING FOR SHORT GUARDRAIL POST</p>	<p style="text-align: center; font-weight: bold;">PLATE NUMBER 630.84</p> <hr style="border: 0; border-top: 1px solid black; margin: 5px 0;"/> <p style="text-align: center;">Sheet 1 of 1</p>
---	--	---	--

GUARDRAIL ACCIDENT DAMAGE REPAIR

BEADLE, BROOKINGS, BROWN, BUFFALO, CLARK, CODINGTON, DAY, DEUEL, EDMUNDS, FAULK, GRANT, HAMLIN, HAND, HYDE, KINGSBURY, MCPHERSON, MARSHALL, MOODY, ROBERTS, AND SPINK COUNTIES

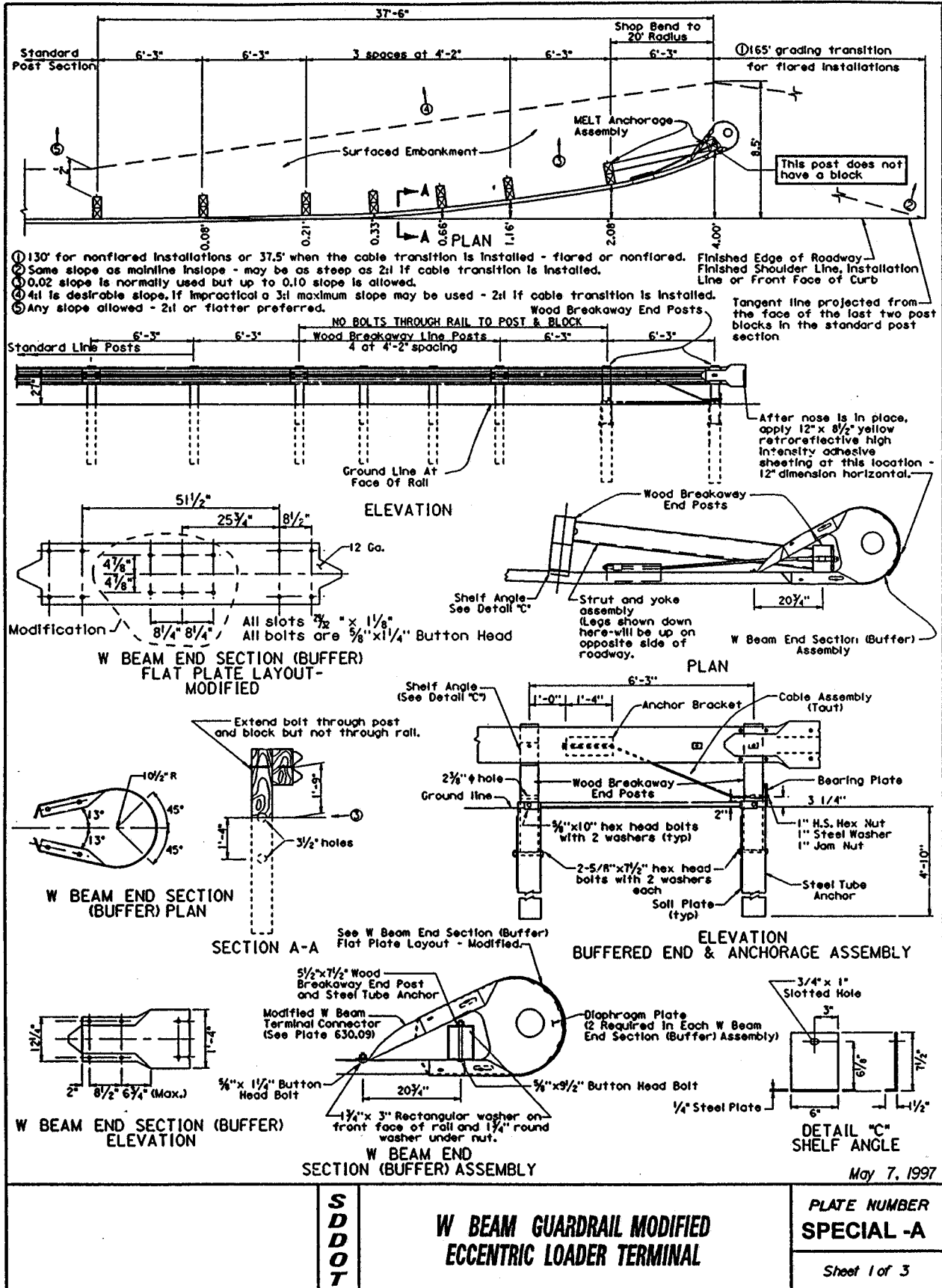

GUARDRAIL ACCIDENT DAMAGE REPAIR

BEADLE, BROOKINGS, BROWN, BUFFALO, CLARK, CODINGTON, DAY, DEUEL, EDMUNDS, FAULK, GRANT,
HAMLIN, HAND, HYDE, KINGSBURY, MCPHERSON, MARSHALL, MOODY, ROBERTS, AND SPINK COUNTIES

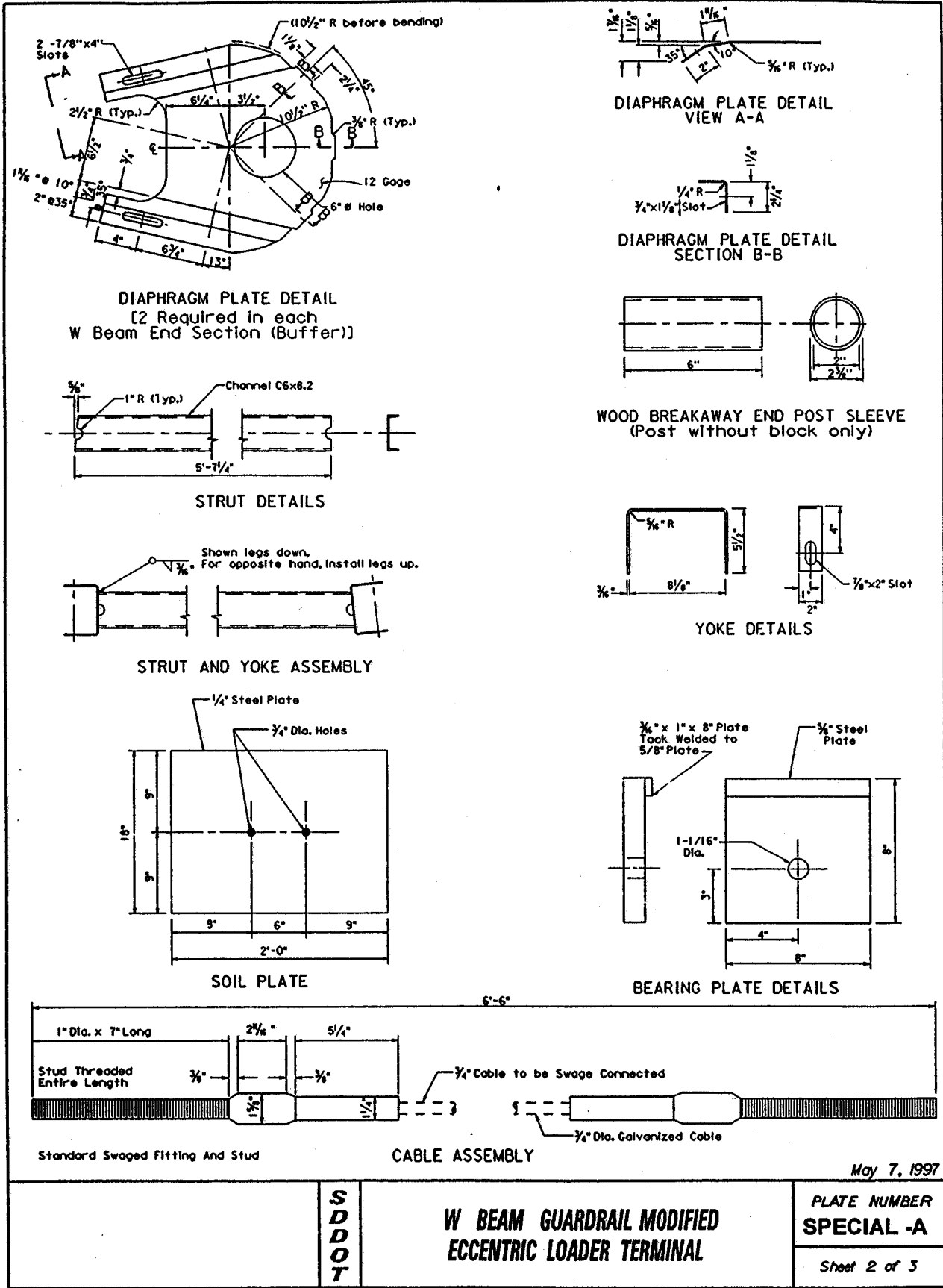

**S
D
D
O
T**

**W BEAM GUARDRAIL MODIFIED
ECCENTRIC LOADER TERMINAL**

**PLATE NUMBER
SPECIAL -A**

Sheet 2 of 3

GUARDRAIL ACCIDENT DAMAGE REPAIR

BEADLE, BROOKINGS, BROWN, BUFFALO, CLARK, CODINGTON, DAY, DEUEL, EDMUNDS, FAULK, GRANT,
HAMLIN, HAND, HYDE, KINGSBURY, MCPHERSON, MARSHALL, MOODY, ROBERTS, AND SPINK COUNTIES

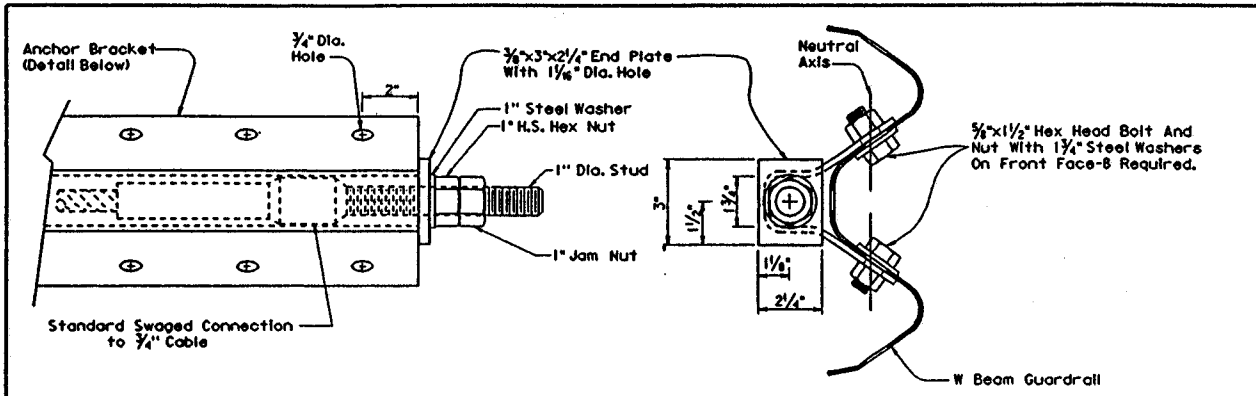

ANCHOR BRACKET ASSEMBLY DETAILS

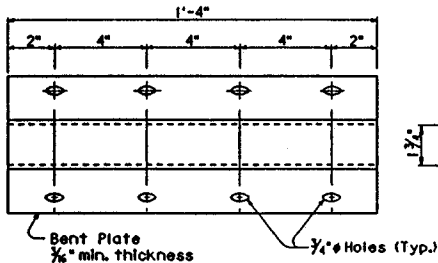

ANCHOR BRACKET

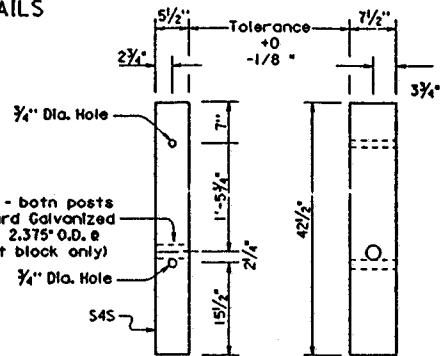

WOOD BREAKAWAY END POST

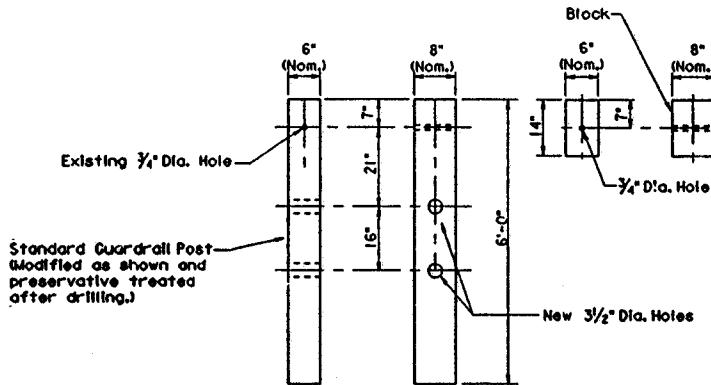

WOOD BREAKAWAY LINE POST AND BLOCK

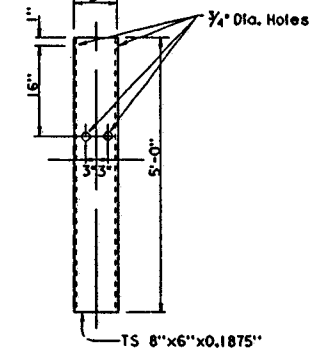

STEEL TUBE ANCHOR

GENERAL NOTES:

1. All angles, channels, and plates shall conform to the requirements of A.S.T.M. A36 and structural tubing to A.S.T.M. A500 or A.S.T.M. A513, Grade 1008. Diaphragm plate shall conform to A.S.T.M. A36 or AASHTO M180. Welding shall meet the current requirements of the American Welding Society Structural Welding Code ANSI/AASHTO/AWS D1.5. All structural steel shall be galvanized in accordance with A.S.T.M. A123. No punching, cutting, or drilling will be permitted after galvanizing. All hardware shall be galvanized according to ASTM A153.
2. The two (2) Wood Breakaway End Posts shall be made of S4S timber with a stress grade of 1200 psi and shall be grademarked or certified by a recognized association or agency which is certified by the Board of Review, American Lumber Standards Committee, to grade the species. They shall receive a preservative treatment in accordance with AASHTO designation M133.
3. The post offset dimensions are given to the center of the traffic face of the blockouts, except at the first post, where the dimension is to the center of the traffic face of the post. Offset points are to be located by chord measurements at the back of rail equal to the nominal post spacings shown. Posts are to be set approximately radial to the railing at each post location.
4. The contract unit price per each for W BEAM GUARDRAIL MODIFIED ECCENTRIC LOADER TERMINAL is to include the anchor bracket, cable assembly, steel tube anchors with all plates, bearing plate, wood breakaway end post sleeve, modified W beam terminal connector, diaphragm plates, strut, W beam and section, retroreflective adhesive sheeting, shelf angle and all hardware and labor to attach the above to the W beam guardrail. The wood breakaway end posts, wood breakaway line posts, wood breakaway line posts, [the cost of shop bending the last half of the end section containing the anchor bracket to a 20' radius], and the guardrail will be paid for at the contract unit price per linear foot for W BEAM GUARDRAIL STRAIGHT, CLASS A, WOOD POSTS.

May 7, 1997

S D D O T	W BEAM GUARDRAIL MODIFIED ECCENTRIC LOADER TERMINAL	PLATE NUMBER SPECIAL -A
		Sheet 3 of 3