

STATE OF SD	PROJECT	SHEET NO.	TOTAL SHEETS
	248-391	1	12

STATE OF SOUTH DAKOTA  
DEPARTMENT OF TRANSPORTATION  
PLANS FOR PROPOSED

**PROJECT 248-391**  
**SD HIGHWAY 248**  
**LYMAN COUNTY**

PIPE REPAIR, EROSION REPAIR, AND OUTLET PROTECTION  
PCN 12FT

**INDEX OF SHEETS**

Sheet No. 1	Title Sheet & Layout Map
Sheet Nos. 2-7	Estimate of Quantities & Plan Notes
Sheet No. 8	Summary of Quantities
Sheet No. 9	Sign Tabulation
Sheet Nos. 10-12	Standard Plates

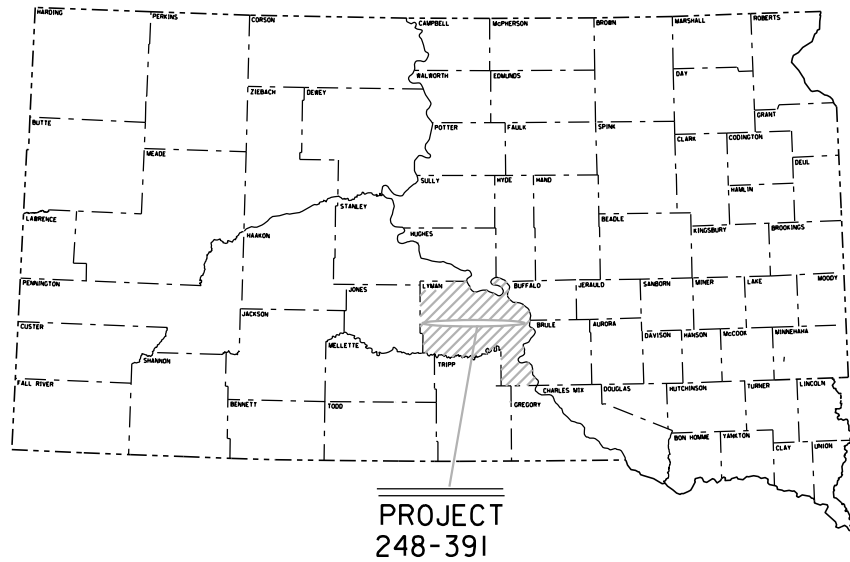

PROJECT 248-391

248-391 PCN 12FT  
LYMAN COUNTY  
DESIGN DESIGNATION

ADT (2011)	177
ADT (2031)	204
DHV	27.8
D	50%
T DHV	4.3%
T ADT	9.4%
V	55 mph

BEGIN PROJECT    END PROJECT  
248-391                    248-391  
MRM 225.34              MRM 262.44

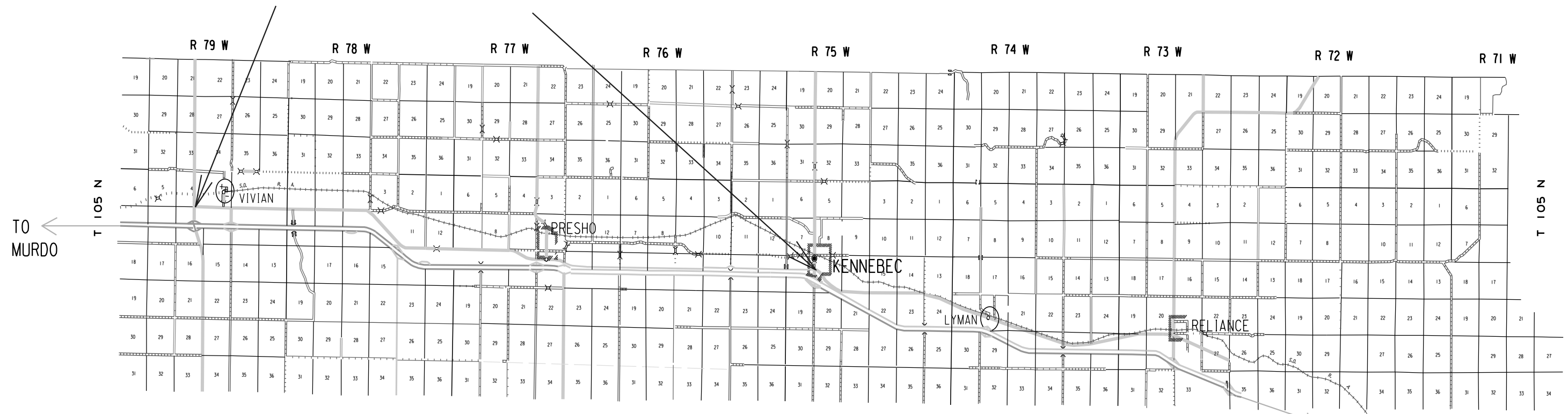

STORMWATER PERMIT  
None Required

404 PERMIT  
Tributaries to Medicine Creek  
Tributary to Red Butte Creek

TO  
CHAMBERLAIN

TO  
MURDO

## ESTIMATE OF QUANTITIES

Bid Item Number	Item	Quantity	Unit
009E0010	Mobilization	Lump Sum	LS
110E0510	Remove Pipe End Section	1	Each
110E7500	Remove Pipe for Reset	102	Ft
110E7510	Remove Pipe End Section for Reset	30	Each
120E0600	Contractor Furnished Borrow	145	CuYd
450E2028	36" RCP Flared End, Furnish	1	Each
450E2029	36" RCP Flared End, Install	1	Each
450E9000	Reset Pipe	102	Ft
450E9001	Reset Pipe End Section	30	Each
634E0010	Flagging	40	Hour
634E0100	Traffic Control	374	Unit
634E0120	Traffic Control, Miscellaneous	Lump Sum	LS
700E0210	Class B Riprap	128.0	Ton
730E0210	Type F Permanent Seed Mixture	16	Lb
732E0100	Mulching	1.2	Ton
734E0154	12" Diameter Erosion Control Wattle	580	Ft
831E0110	Type B Drainage Fabric	116	SqYd

## SPECIFICATIONS

South Dakota Standard Specifications for Roads and Bridges, 2004 Edition and Required Provisions, Supplemental Specifications and/or Special Provisions as included in the Proposal.

## GENERAL MAINTENANCE OF TRAFFIC

The sign tabulation units were calculated assuming one work zone would be used. Traffic control signs furnished will be paid for only once. The cost of moving signs within project limits or from project to project shall be incidental to the contract unit price per unit for "Traffic Control".

Removing, relocating, covering, salvaging and resetting of existing traffic control devices, including delineation, shall be the responsibility of the Contractor. Cost for this work shall be incidental to the contract unit prices for the various items unless otherwise specified in the plans. Any delineators and signs damaged or lost shall be replaced by the Contractor at no cost to the State.

## GENERAL MAINTENANCE OF TRAFFIC - CONTINUED

Storage of vehicles and equipment shall be outside the clear zone and as near as possible to the right-of-way line. Contractor's employees should mobilize at a location off the right-of-way and arrive at the work sites in a minimum number of vehicles necessary to perform the work.

Indiscriminate driving and parking of vehicles within the right-of-way will not be permitted. Any damage to the vegetation, surfacing, embankment, delineators and existing signs resulting from such indiscriminate use shall be repaired and/or restored by the Contractor, at no expense to the State, and to the satisfaction of the Engineer.

The Contractor shall provide documentation that all breakaway sign supports comply with FHWA NCHRP Report 350 or MASH crash-worthy requirements. The Contractor shall provide installation details at the preconstruction meeting for all breakaway sign support assemblies.

Highway equipment working within traffic or adjacent to traffic shall, at all times, display a flashing or revolving amber light to warn the traveling public.

Channelizing devices in a series shall be of the same type. All traffic control devices shall be in "like new" condition.

All construction operations shall be conducted in the general direction of traffic movement. All signs shall be mounted on portable supports. The bottom of signs on portable or temporary supports shall not be less than seven feet above the pavement in urban areas and one foot above the pavement in rural areas. Portable sign supports may be used as long as the duration is less than three (3) days. If the duration is more than three (3) days, the signs shall be on fixed supports.

## GENERAL MAINTENANCE OF TRAFFIC - CONTINUED

Additional standard signs, as ordered by the Engineer, shall be available within two (2) working days. Failure to provide signs within this time limit will result in liquidated damages being assessed in the amount of \$100.00 per calendar day. Payment for additional signs will be paid for using the contract unit price per unit for "Traffic Control".

The Contractor shall furnish, install and maintain Truck Crossing signs. The exact number and location will be determined on construction. Payment shall be incidental to the contract unit price per unit for "Traffic Control" and will be paid for once on the project.

## UTILITIES

The Contractor shall contact the involved utility companies through South Dakota One Call (1-800-781-7474) prior to starting work. It shall be the responsibility of the Contractor to coordinate work with the utility company to avoid damage to existing facilities.

Utilities are not planned to be affected on this project. If utilities are identified near the improvement area through the SD One Call process as required by South Dakota Codified Law 49-7A and Administrative Rule Article 20:25; the Contractor shall contact the Project Engineer to determine modifications that will be necessary to avoid utility impacts.

STATE OF	PROJECT	SHEET NO.	TOTAL SHEETS
SD	248-391	3	12

**PIPE NOTES**

The Contractor is responsible for verifying the size of each pipe prior to ordering any pipe. The Contractor shall obtain the approval of the Engineer before ordering any pipe.

Pipe culverts that are removed and not reset shall become the property of the Contractor. Pipe culverts shall be disposed of as per the waste disposal site notes and shall not be in view from the project upon completion of the project.

The excavation required to expose existing pipe and ends will be incidental to the contract unit prices for Remove Pipe for Reset, Remove Pipe End Section for Reset, and corresponding pipe install bid items.

**TIE BOLTS FOR RCP**

Tie Bolts shall be installed at the inlet and outlet on the first three sections of new/reset culvert and on new/reset culvert ends (requires connection from existing culvert to new end section).

*For informational purposes:* Field drilling will be required to install the tie bolts on reset culvert, on reset culvert ends and on existing culvert when installing a new/reset end section.

Cost for removing tie bolts, drilling tie bolt holes and furnishing and installing tie bolts shall be incidental to the contract unit prices for installing or resetting RCP Culverts and End Sections. Existing tie bolts may be salvaged and reused if condition is acceptable to the Engineer.

**CONTRACTOR FURNISHED BORROW**

Contractor Furnished Borrow shall be required to fill in scour holes and other erosion as noted in the scope of work for the individual repair sites. All fill material shall meet with the approval of the Engineer. Borrow Areas within the right-of-way may be available with prior approval of the Engineer. The plans quantity for "Contractor Furnished Borrow" as shown in the Estimate of Quantities will be the basis of payment for this item unless the Engineer orders changes. The Contractor is responsible for obtaining all required permits and clearances for the borrow site.

Prior to placement of fill material, the Contractor will be required to remove 3 inches of topsoil and replace it on the newly constructed embankments. Payment for the above shall be incidental to the contract unit price per cubic yard for "Contractor Furnished Borrow".

All work shall be accomplished within the right-of-way.

Once a work site is opened up at a given location, work shall proceed in a continuous manner to minimize the potential for erosion.

It is anticipated that water for compaction will not be required. When, in the opinion of the Engineer, the fill material is dry, water may be ordered and placed to the satisfaction of the Engineer. The cost of water shall be incidental to the contract unit price per cubic yard for "Contractor Furnished Borrow".

Compaction of the fill material shall be to the satisfaction of the Engineer.

**HISTORICAL PRESERVATION OFFICE CLEARANCES**

To obtain State Historical Preservation Office (SHPO) clearance, a cultural resources survey may need to be conducted by a qualified archaeologist. In lieu of a cultural resources survey, the Contractor could request a records search from Jim Donohue, State Archaeological Research Center (SARC). Provide SARC with the following: a topographical map or aerial view on which the site is clearly outlined, site dimensions, project number, and PCN. If applicable, provide evidence that the site has been previously disturbed by farming, mining, or construction activities with a landowner statement that no artifacts have been found on the site. The Contractor shall arrange and pay for the cultural resource survey and/or records search.

If any earth disturbing activities occur within the current geographical or historic boundaries of any South Dakota reservation, the Contractor shall obtain Tribal Historical Preservation Office (THPO) clearance. If no THPO exists, the required SHPO clearance shall suffice, with documentation of Tribal contact efforts provided to SHPO.

To facilitate SHPO or THPO responses, the Contractor should submit a records search or cultural resources survey report to the DOT Environmental Engineer, 700 East Broadway Avenue, Pierre, SD 57501-2586 (605-773-3268). Allow 30 days from the date this information is submitted to the Environmental Engineer for SHPO/THPO approval. The Contractor is responsible for obtaining all required permits and clearances for staging areas, borrow sites, waste disposal sites, and all material processing sites. The Contractor shall provide the required permits and clearances to the Engineer at the preconstruction meeting.

**TYPE F PERMANENT SEED MIXTURE**

All disturbed areas within the right-of-way shall be seeded with Type F Permanent Seed Mixture.

Permanent Seeding will be measured and paid for where embankment work is accomplished.

Seeding of borrow areas within the right-of-way will be required as specified above but will not be measured for payment. Restoration of borrow areas outside the right-of-way will be as per agreement with the landowner and will not be paid for.

Hand seeding devices approved by the Engineer will be allowed. All seed broadcast, including the use of a hydroseeder, must be raked or dragged in (incorporated) with the top 1/4 to 1/2 inch of topsoil to the satisfaction of the Engineer.

Type F Permanent Seed Mixture shall consist of the following:

Grass Species	Variety	Pure Live Seed (PLS) (Pounds/Acre)
Western Wheatgrass	Flintlock, Rodan, Rosana	7
Green Needlegrass	Lodorm	4
Sideoats Grama	Butte, Killdeer, Pierre, Trailway	3
Blue Grama	Bad River, Willis	2
Oats or Spring Wheat: April through July; Winter Wheat: August through November		10
Total:		26

**FERTILIZING**

Application of fertilizer will not be required on this project.

**MULCHING (HAY OR STRAW)**

Following permanent seeding, mulch consisting of grass hay or straw shall be blown on at the rate of 2 tons per acre and punched in on slopes 3:1 and flatter and on 2:1 slopes where equipment can be operated without rutting the slope due to slippage.

Bales shall be inspected for noxious weeds by the County Weed Supervisor in which the bales are to be used. This shall be done prior to construction activities. The Contractor shall provide written verification from the County Weed Supervisor stating the bales are free of noxious weeds.

Bales with noxious weed contamination will be rejected and the Contractor will be required to remove the contaminated bales from the project.

**EROSION CONTROL WATTLES**

Erosion control wattles for restraining the flow of runoff and sediment shall be installed at locations determined by the Engineer during construction. Refer to Standard Plate 734.06 for details.

The Contractor shall provide certification that the erosion control wattles do not contain noxious weed seeds.

A quantity of 580 feet of 12" Diameter Erosion Control Wattles has been added to the Estimate of Quantities for temporary erosion and sediment control around excavation and/or borrow piles and the pipe ends while pipe clean out work is being completed.

**EROSION CONTROL WATTLES (CONTINUED)**

The erosion control wattle provided shall be from the list shown below:

Product	Manufacturer
Curlex Sediment Log AEC Premier Straw Wattles	American Excelsior Company Arlington, TX Phone: 1-800-777-7645 <a href="http://www.amerexcel.com">www.amerexcel.com</a>
Aspen Excelsior Logs and Excel Straw Logs	Western Excelsior Corporation Mancos, CO Phone: 1-800-833-8573 <a href="http://www.westernexcelsior.com">www.westernexcelsior.com</a>
Earth Saver Rice Straw Wattles	R.H. Dyck Inc. Winters, CA Phone: 1-866-928-8537 <a href="http://www.earth-savers.com">www.earth-savers.com</a>
EarthTec Erosion Control Wattles	EarthTec/the Dukes, Inc. Devils Lake, ND Phone: 1-701-662-6666
Bio Logs	Flaxtech, LLC Rock Lake, ND Phone: 1-866-444-3529
Stenlog	ECB Bioproducts St. Andrews, MB Phone: 1-866-317-3346 <a href="http://www.erosioncontrolblanket.com">www.erosioncontrolblanket.com</a>
Winters Wattles	Winters Excelsior Company Birmingham, AL Phone: 1-800-248-7237 <a href="http://www.wintersexcelsior.com">www.wintersexcelsior.com</a>
Patriot Wood Fiber Logs and Patriot Straw Wattles	Patriot Environmental Products, Inc. Mesa, AZ Phone: 1-480-345-7293 <a href="http://www.digitaldesigncore.com/patriot/WattleSpecs.pdf">www.digitaldesigncore.com/patriot/WattleSpecs.pdf</a>

**TABLE OF CLASS B RIPRAP**

<u>Hwy</u>	<u>MRM</u>	<u>Rt/Lt</u>	<u>Ton</u>
SD248	251.52	Rt	64
SD248	252.78	Lt	64

**TABLE OF TYPE B DRAINAGE FABRIC**

<u>Hwy</u>	<u>MRM</u>	<u>Rt/Lt</u>	<u>Sq.Yds.</u>
SD248	251.52	Rt	58
SD248	252.78	Lt	58
		Total:	116

**WASTE DISPOSAL SITE**

The Contractor will be required to furnish a site(s) for the disposal of construction/demolition debris generated by this project.

Construction/demolition debris may not be disposed of within the State ROW.

The waste disposal site(s) shall be managed and reclaimed in accordance with the following from the General Permit for Highway, Road, and Railway Construction/Demolition Debris Disposal Under the South Dakota Waste Management Program issued by the Department of Environment and Natural Resources.

The waste disposal site(s) shall not be located in a wetland, within 200 feet of surface water, or in an area that adversely affects wildlife, recreation, aesthetic value of an area, or any threatened or endangered species, as approved by the Engineer.

If the waste disposal site(s) is located such that it is within view of any ROW, the following additional requirements shall apply:

1. Construction/demolition debris consisting of concrete, asphalt concrete, or other similar materials shall be buried in a trench completely separate from wood debris. The final cover over the construction/demolition debris shall consist of a minimum of 1 foot of soil capable of supporting vegetation. Waste disposal sites provided outside of the State ROW shall be seeded in accordance with Natural Resources Conservation Service recommendations. The seeding recommendations may be obtained through the appropriate County NRCS Office. The Contractor shall control the access to waste disposal sites not within the State ROW through the use of fences, gates, and placement of a sign or signs at the entrance to the site stating "No Dumping Allowed".
2. Concrete and asphalt concrete debris may be stockpiled within view of the ROW for a period of time not to exceed the duration of the project. Prior to project completion, the waste shall be removed from view of the ROW or buried and the waste disposal site reclaimed as noted above.

**WASTE DISPOSAL SITE (CONTINUED)**

The above requirements will not apply to waste disposal sites that are covered by an individual solid waste permit as specified in SDCL 34A-6-58, SDCL 34A-6-1.13, and ARSD 74:27:10:06.

Failure to comply with the requirements stated above may result in civil penalties in accordance with South Dakota Solid Waste Law, SDCL 34A-6-1.31.

All costs associated with furnishing waste disposal site(s), disposing of waste, maintaining control of access (fence, gates, and signs), and reclamation of the waste disposal site(s) shall be incidental to the various contract items.

STATE OF	PROJECT	SHEET NO.	TOTAL SHEETS
SD	248-391	6	12

## **SCOPE OF WORK**

### **SD248 MRM 225.34 to 262.44**

**MRM 228.89** The site work on the right consists of removing and resetting the end section and one four foot section of the existing 18" RCP. The inlet shall be cleaned out to allow drainage to the pipe. The site work on the left consists of removing and resetting the end section and two six foot sections of the existing 18" RCP. The outlet shall be cleaned out to the North East to allow drainage away from the pipe. Excess dirt removed from this area shall be disposed of by the Contractor or used as Contractor Furnished Borrow at other locations throughout the project. Scour holes and erosion shall be filled in with Contractor Furnished Borrow. All disturbed areas will be seeded and mulched.

**MRM 231.94** The site work on the right consists of removing and resetting the end section of the existing 18" RCP. The inlet shall be cleaned out to allow drainage to the pipe. The site work on the left consists of removing and resetting the end section and two four foot sections of the existing 18" RCP. The outlet shall be cleaned out to allow drainage away from the pipe. Excess dirt removed from this area shall be disposed of by the Contractor or used as Contractor Furnished Borrow at other locations throughout the project. Scour holes and erosion shall be filled in with Contractor Furnished Borrow. All disturbed areas will be seeded and mulched.

**MRM 238.09** The site work on the right consists of removing and resetting the end section, one four foot section and one six foot section of the existing 24" RCP. The inlet shall be cleaned out to allow drainage to the pipe. The site work on the left consists of removing and resetting the end section and two six foot sections of the existing 24" RCP. The outlet shall be cleaned out to allow drainage away from the pipe. Excess dirt removed from this area shall be disposed of by the Contractor or used as Contractor Furnished Borrow at other locations throughout the project. Scour holes and erosion shall be filled in with Contractor Furnished Borrow. All disturbed areas will be seeded and mulched.

**MRM 238.84** There is no work required on the right side. The site work on the left consists of removing and resetting the end section of the existing 18" RCP. The inlet shall be cleaned out to allow drainage to the pipe. Excess dirt removed from this area shall be disposed of by the Contractor or used as Contractor Furnished Borrow at other locations throughout the project. Scour holes and erosion shall be filled in with Contractor Furnished Borrow. All disturbed areas will be seeded and mulched.

**MRM 238.90** There is no work required on the right side. The site work on the left consists of removing and resetting the end section of the existing 18" RCP. The inlet shall be cleaned out for approximately 30 feet to allow drainage to the pipe. Excess dirt removed from this area shall be disposed of by the Contractor or used as Contractor Furnished Borrow at other locations throughout the project. Scour holes and erosion shall be filled in with Contractor Furnished Borrow. All disturbed areas will be seeded and mulched.

**MRM 238.92** There is no work required on the right side. The site work on the left consists of removing and resetting the end section of the existing 18" RCP. The inlet shall be cleaned out for approximately 30 feet to allow drainage to the pipe. Excess dirt removed from this area shall be disposed of by the Contractor or used as Contractor Furnished Borrow at other locations throughout the project. Scour holes and erosion shall be filled in with Contractor Furnished Borrow. All disturbed areas will be seeded and mulched.

**MRM 239.92** The site work on the right consists of removing and resetting the end section of the existing 18" RCP. The inlet shall be cleaned out to allow drainage to the pipe. The site work on the left consists of removing and resetting the end section and one six foot section of the existing 18" RCP. The outlet shall be cleaned out to allow drainage away from the pipe. Excess dirt removed from this area shall be disposed of by the Contractor or used as Contractor Furnished Borrow at other locations throughout the project. Scour holes and erosion shall be filled in with Contractor Furnished Borrow. All disturbed areas will be seeded and mulched.

**MRM 240.98** The site work on the right consists of removing and resetting the end section of the existing 4' x 6' Cattle Pass. The inlet shall be cleaned out to allow drainage to the pipe. The site work on the left consists of removing and resetting the end section of the existing 4' x 6' Cattle Pass. The outlet shall be cleaned out to allow drainage away from the pipe. Excess dirt removed from this area shall be disposed of by the Contractor or used as Contractor Furnished Borrow at other locations throughout the project. Scour holes and erosion shall be filled in with Contractor Furnished Borrow. All disturbed areas will be seeded and mulched.

**MRM 245.64** The site work on the right consists of removing and resetting the end section of the existing 18" RCP. The outlet shall be cleaned out to allow drainage away from the pipe. The site work on the left consists of removing and resetting the end section of the existing 18" RCP. The inlet shall be cleaned out to allow drainage to the pipe. Excess dirt removed from this area shall be disposed of by the Contractor or used as Contractor Furnished Borrow at other locations throughout the project. Scour holes and erosion shall be filled in with Contractor Furnished Borrow. All disturbed areas will be seeded and mulched.

STATE OF	PROJECT	SHEET NO.	TOTAL SHEETS
SD	248-391	7	12

**SCOPE OF WORK (CONTINUED)**

**MRM 247.49** The site work on the right consists of removing and resetting the end section of the existing 18" RCP. The inlet shall be cleaned out to allow drainage to the pipe. The site work on the left consists of removing and resetting the end section of the existing 18" RCP. The outlet shall be cleaned out to allow drainage away from the pipe. Excess dirt removed from this area shall be disposed of by the Contractor or used as Contractor Furnished Borrow at other locations throughout the project. Scour holes and erosion shall be filled in with Contractor Furnished Borrow. All disturbed areas will be seeded and mulched.

**MRM 248.36** The site work on the right consists of removing and resetting the end section and one four foot section of the existing 24" RCP. The inlet shall be cleaned out to allow drainage to the pipe. The site work on the left consists of removing and resetting the end section of the existing 24" RCP. The outlet shall be cleaned out to allow drainage away from the pipe. Excess dirt removed from this area shall be disposed of by the Contractor or used as Contractor Furnished Borrow at other locations throughout the project. Scour holes and erosion shall be filled in with Contractor Furnished Borrow. All disturbed areas will be seeded and mulched.

**MRM 249.41** The site work on the right consists of removing and resetting the end section of the existing 18" RCP. The inlet shall be cleaned out to allow drainage to the pipe. The site work on the left consists of removing and resetting the end section and one six foot section of the existing 18" RCP. The outlet shall be cleaned out to allow drainage away from the pipe. Excess dirt removed from this area shall be disposed of by the Contractor or used as Contractor Furnished Borrow at other locations throughout the project. Scour holes and erosion shall be filled in with Contractor Furnished Borrow. All disturbed areas will be seeded and mulched.

**MRM 251.52** The site work on the right consists of Type B Drainage Fabric and Class B Riprap placed to a volume of 16' wide x 20' long x 2.5' deep on the outlet of the existing 8' x 8' Box Culvert. The outlet shall be cleaned out to the South East to allow drainage to the Right of Way. Excess dirt removed from this area shall be disposed of by the Contractor or used as Contractor Furnished Borrow at other locations throughout the project. Scour holes and erosion shall be filled in with Contractor Furnished Borrow. All disturbed areas will be seeded and mulched. There is no work required on the left side.

**MRM 252.78** The site work on the right consists of cleaning out a 30' x 50' area at the inlet of the existing 4' x 4' Box Culvert to allow drainage to the pipe. The site work on the left consists of Type B Drainage Fabric and Class B Riprap placed to a volume of 16' wide x 20' long x 2.5' deep on the outlet of the existing 4' x 4' Box Culvert. The outlet shall be cleaned out to the West to allow drainage away from the pipe. Excess dirt removed from this area shall be disposed of by the Contractor or used as Contractor Furnished Borrow at other locations throughout the project. Scour holes and erosion shall be filled in with Contractor Furnished Borrow. All disturbed areas will be seeded and mulched. There is no work required on the left side.

**MRM 253.81** The site work on the right consists of removing and resetting one end section and removing and replacing one end section of the existing twin 36" RCP. The inlet shall be cleaned out to allow drainage to the pipe. The site work on the left consists of removing and resetting the end sections and one six foot section on each pipe of the existing twin 36" RCP. The outlet shall be cleaned out to an approximate depth of 1.5' to the Right of Way to allow drainage away from the pipe. Excess dirt removed from this area shall be disposed of by the Contractor or used as Contractor Furnished Borrow at other locations throughout the project. Scour holes and erosion shall be filled in with Contractor Furnished Borrow. All disturbed areas will be seeded and mulched.

**MRM 258.89** The site work on the right consists of removing and resetting the end section of the existing 36" RCP. The inlet shall be cleaned out to allow drainage to the pipe. The site work on the left consists of removing and resetting the end section and one four foot section of the existing 36" RCP. The outlet shall be cleaned out to an approximate depth of 2' to the Right of Way to allow drainage away from the pipe. Excess dirt removed from this area shall be disposed of by the Contractor or used as Contractor Furnished Borrow at other locations throughout the project. Scour holes and erosion shall be filled in with Contractor Furnished Borrow. All disturbed areas will be seeded and mulched.

**MRM 260.75** The site work on the right consists of removing and resetting the end sections and one six foot section on each pipe of the existing twin 36" RCP. The inlet shall be cleaned out to allow drainage to the pipe. The site work on the left consists of removing and resetting the end sections and one six foot section on each pipe of the existing twin 36" RCP. The outlet shall be cleaned out to allow drainage away from the pipe. Excess dirt removed from this area shall be disposed of by the Contractor or used as Contractor Furnished Borrow at other locations throughout the project. Scour holes and erosion shall be filled in with Contractor Furnished Borrow. All disturbed areas will be seeded and mulched.

**SUMMARY OF QUANTITIES (FOR INFORMATION ONLY)**

Installation Quantity by Location (MRM)		SD248											
Bid Item Description	228.89	231.94	238.09	238.84	238.90	238.92	239.92	240.98	245.64	247.49	248.36	249.41	251.52
Mobilization													
Remove Pipe End Section													
Remove Pipe for Reset	16	8	22				6				4	6	
Remove Pipe End Section for Reset	2	2	2	1	1	1	2	2	2	2	2	2	
Contractor Furnished Borrow	10	10	10	5	5	5	10	10	10	10	10	10	5
36" RCP Flared End, Furnish													
36" RCP Flared End, Install													
Reset Pipe	16	8	22				6				4	6	
Reset Pipe End Section	2	2	2	1	1	1	2	2	2	2	2	2	
Flagging													
Traffic Control													
Traffic Control, Miscellaneous													
Class B Riprap													64
Type F Permanent Seed Mixture	1	1	1	.5	1	.5	1	1	1	1	1	1	1
Mulching													
12" Diameter Erosion Control Wattle	40	40	40	20	20	20	40	40	40	40	40	40	20
Type B Drainage Fabric													58

Installation Quantity by Location (MRM)		SD248				Quantity	Unit
Bid Item Description	252.78	253.81	258.89	260.75			
Mobilization					LS	LS	
Remove Pipe End Section		1			1	Each	
Remove Pipe for Reset		12	4	24	102	Ft	
Remove Pipe End Section or Reset		3	2	4	30	Each	
Contractor Furnished Borrow	5	10	10	10	145	CuYd	
36" RCP Flared End, Furnish		1			1	Each	
36" RCP Flared End, Install		1			1	Each	
Reset Pipe		12	4	24	102	Ft	
Reset Pipe End Section		3	2	4	30	Each	
Flagging					40	Hour	
Traffic Control					374	Unit	
Traffic Control, Miscellaneous					Lump Sum	LS	
Class B Riprap	64				128	Ton	
Type F Permanent Seed Mixture	1	1	1	1	16	Lb	
Mulching					1.2	Ton	
12" Diameter Erosion Control Wattle	20	40	40	40	580	Ft	
Type B Drainage Fabric	58				116	SqYd	



STATE OF	PROJECT	SHEET NO.	TOTAL SHEETS
SD	248-391	9	12

**SIGN TABULATION**

SIGN CODE	SIGN SIZE	DESCRIPTION	NUMBER REQUIRED	UNITS PER SIGN	UNITS
G20-2	36" x 18"	END ROAD WORK	2	17	34
W8-6	48" x 48"	TRUCK CROSSING	2	34	68
W20-1	48" x 48"	ROAD WORK ##### FT. OR AHEAD	2	34	68
W20-4	48" x 48"	ONE LANE ROAD ##### FT. OR AHEAD	2	34	68
W20-7a	48" x 48"	FLAGGER	2	34	68
W21-5	48" x 48"	SHOULDER WORK	2	34	68
<b>TOTAL UNITS</b>					<b>374</b>

Wall "t" (in.)	Rod Dia. (in.)	Pipe Sleeve Dia. (nominal)
< 3/4	5/8	3/4
3/2-6 1/2	3/4	1
> 7	1	1 1/4

**GENERAL NOTES:**

Tie bolts shall conform to ASTM A307, Grade C. Nuts shall be heavy hex conforming to ASTM A563. Washers shall conform to ASTM F436.

Pipe Sleeve shall conform to ASTM A500 or A53, Grade B.

Galvanize adjustable eye bolt tie assembly in accordance with ASTM A153.

**ADJUSTABLE EYE BOLT TIE**

Pipe Dia. (in.)	"L" (in.)	Bolt Dia. (in.)
< 48	4	3/4
> 48	6	1

**GENERAL NOTES:**

Angles shall conform to ASTM A36.

Bolts shall conform to ASTM A307. Nuts shall be heavy hex conforming to ASTM A563. Washers shall conform to ASTM F436.

Galvanize angles, bolts, nuts, and washers in accordance with ASTM A153.

**ANGLE AND BOLT TIE**

**GENERAL NOTES:**

In lieu of tie bolts detailed above, tecktonius fasteners or other type tie bolt connections may be installed if approved by the Engineer.

The first three sections (both inlet and outlet) of R.C.P. and R.C.P. Arch up to and including the 78" diameter or equivalent pipe shall be tied with tie bolts. Pipe sizes larger than 78" diameter or equivalent diameter shall have all sections tied. Each end section is considered as one section.

There will be no separate measurement or payment for tie bolts. The cost of the tie bolts shall be incidental to the contract unit price per foot for the corresponding bid item for R.C.P. or R.C.P. Arch.

**END VIEW "CIRCULAR"**

**END VIEW "ARCH"**

September 14, 2011

The signs illustrated are not required if the work space is behind a barrier, more than 2 feet behind the curb, or 15 feet or more from the edge of any roadway.

The signs illustrated shall be used where there are distracting situations; such as: vehicles parked on shoulder, vehicles accessing the work site via the highway, and equipment traveling on or crossing the roadway to perform work operations.

The ROAD WORK AHEAD sign may be replaced with other appropriate signs, such as the SHOULDER WORK sign. The SHOULDER WORK sign may be used for work adjacent to the shoulder.

\* If the work space is on a divided highway, an advance warning sign should also be placed on the left side of the directional roadway.

For short term, short duration, or mobile operations, all signs and channelizing devices may be eliminated if a vehicle with an activated flashing or revolving yellow light is used.

Posted Speed Prior to Work (M.P.H.)	Spacing of Advance Warning Signs (Feet) (A)
0 - 30	200
35 - 40	350
45 - 50	500
55	750
60 - 75	1000

July 1, 2005

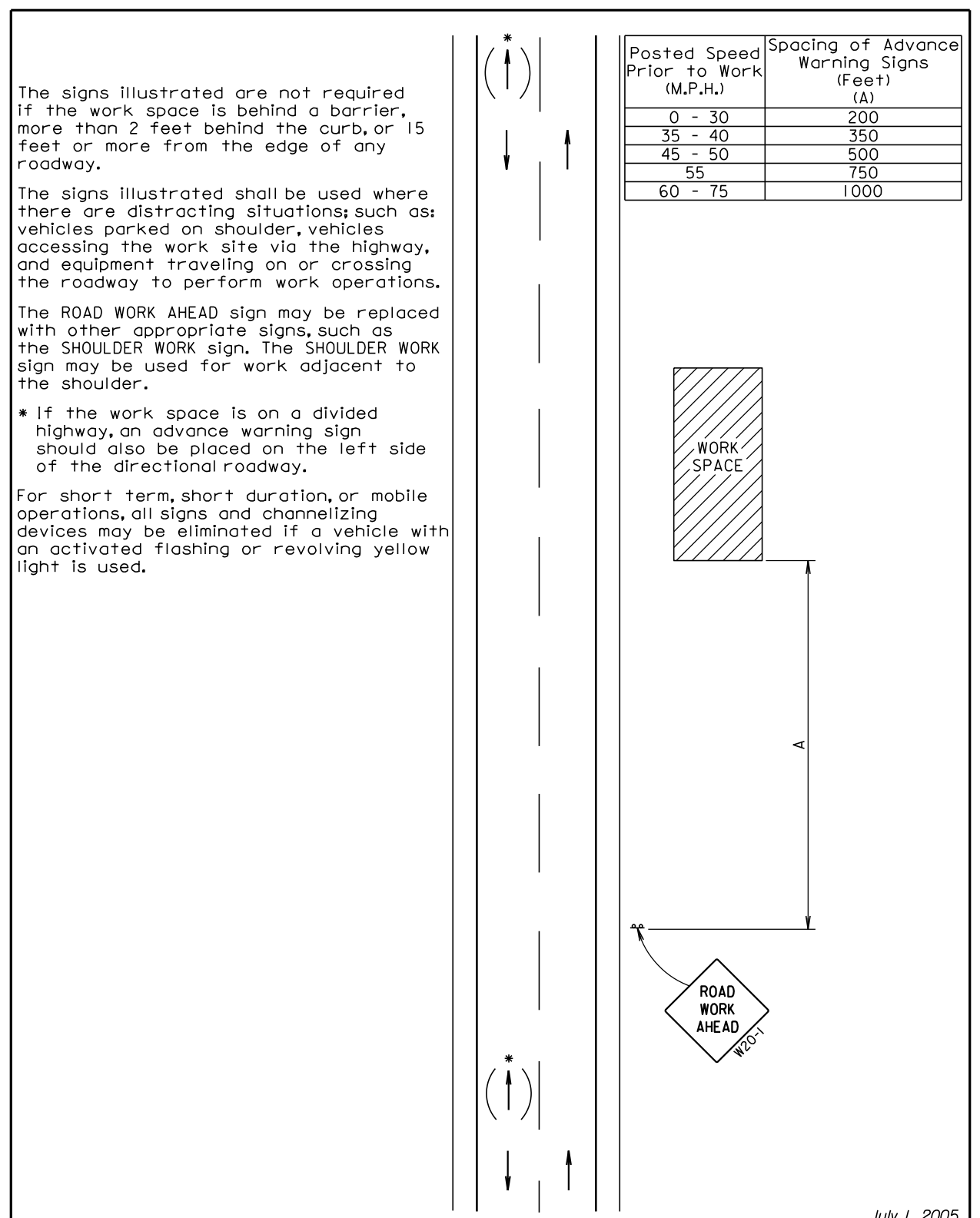

July 1, 2005

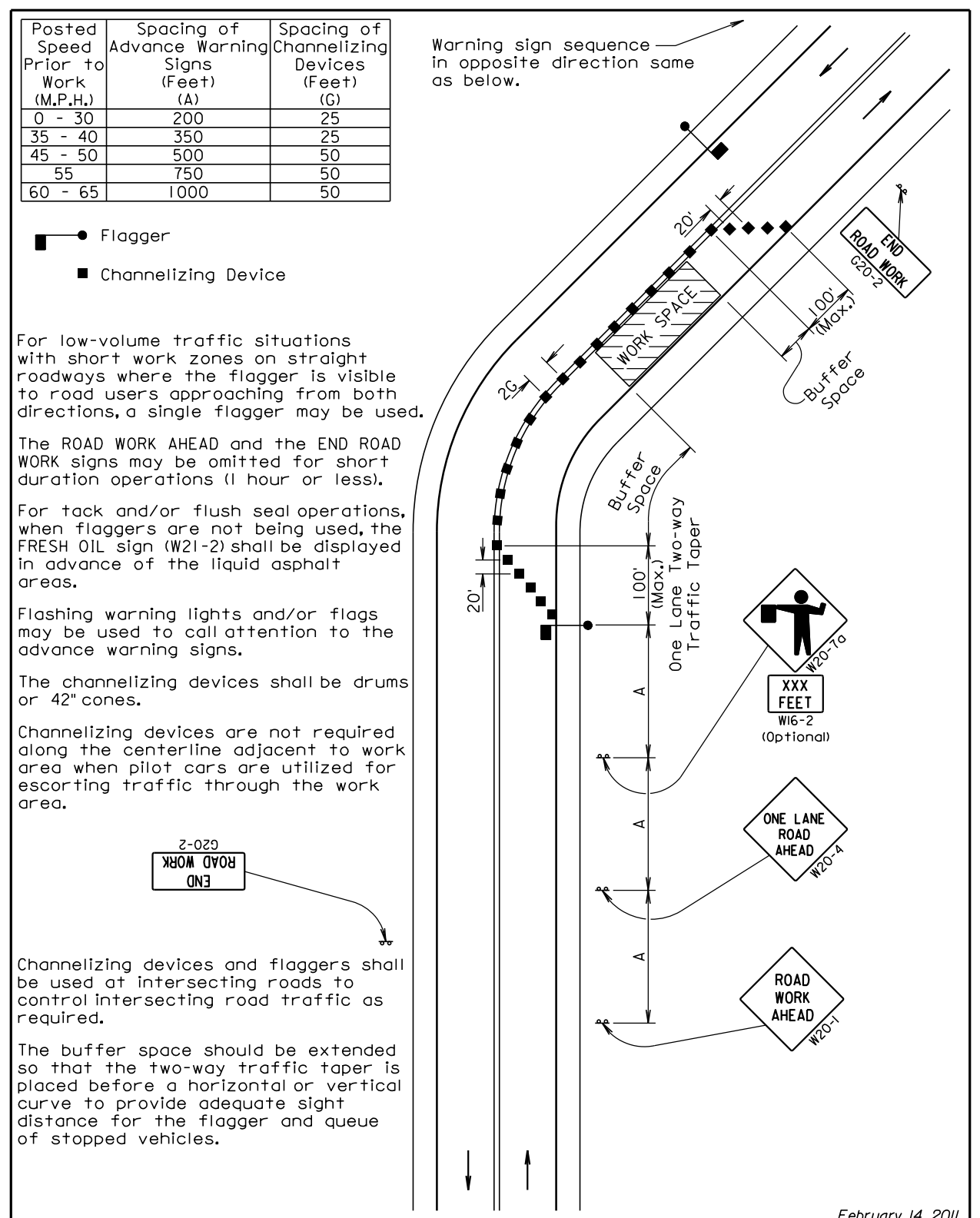

February 14, 2011

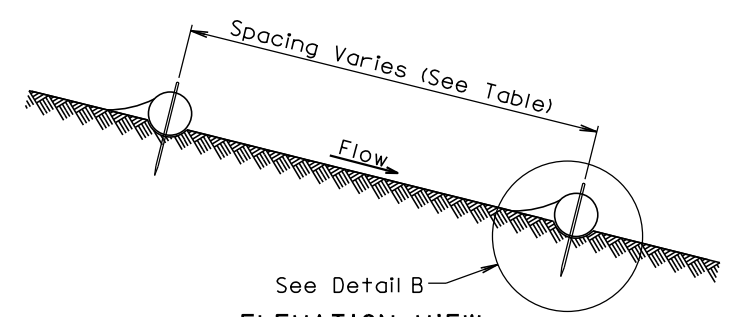

CUT OR FILL SLOPE INSTALLATION	
Slope	Spacing (Ft)
1:1	10
2:1	20
3:1	30
4:1	40

ELEVATION VIEW  
CUT OR FILL SLOPE INSTALLATION

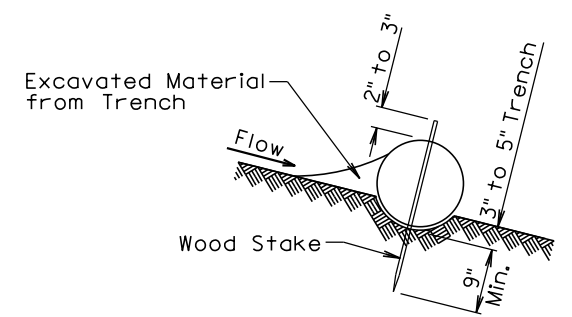

DETAIL B  
(TYPICAL OF ALL INSTALLATIONS)

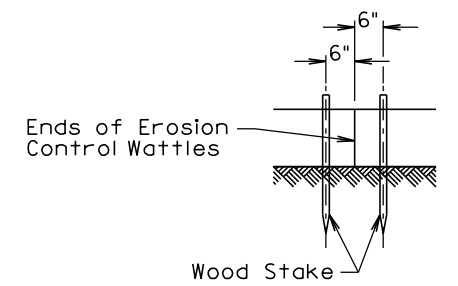

DETAIL C

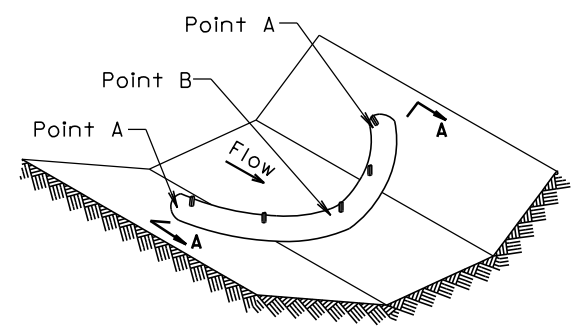

ISOMETRIC VIEW  
DITCH INSTALLATION

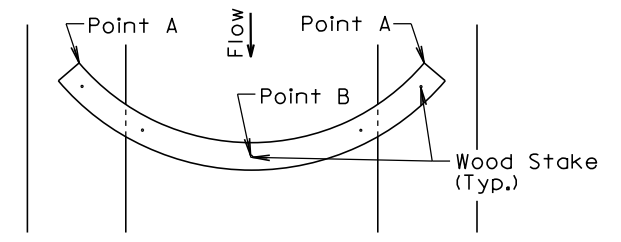

PLAN VIEW  
DITCH INSTALLATION

DITCH INSTALLATION	
Grade	Spacing (Ft)
2%	150
3%	100
4%	75
5%	50

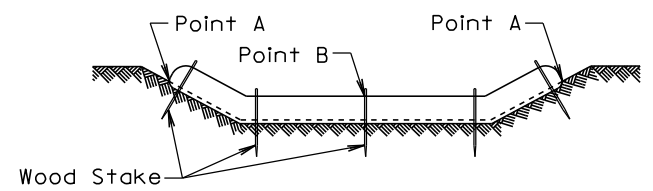

SECTION A-A

December 23, 2004

**GENERAL NOTES:**

At cut or fill slope installations, wattles shall be installed along the contour and perpendicular to the water flow.

At ditch installations, point A must be higher than point B to ensure that water flows over the wattle and not around the ends.

The Contractor shall dig a 3" to 5" trench, install the wattle tightly in the trench so that daylight can not be seen under the wattle, and then compact the soil excavated from the trench against the wattle on the uphill side. See Detail B.

The stakes shall be 1"x2" or 2"x2" wood stakes, however, other types of stakes such as rebar may be used only if approved by the Engineer. The stakes shall be placed 6" from the ends of the wattles and the spacing of the stakes along the wattles shall be 3' to 4'.

Where installing running lengths of wattles, the Contractor shall butt the second wattle tightly against the first and shall not overlap the ends. See Detail C.

The Contractor and Engineer shall inspect the erosion control wattles once every week and within 24 hours after every rainfall event greater than 1/2". The Contractor shall remove, dispose, or reshape the accumulated sediment when necessary as determined by the Engineer.

Sediment removal, disposal, or necessary shaping shall be as directed by the Engineer. All costs for removing accumulated sediment, disposal of sediment, and necessary shaping shall be incidental to the contract unit price per cubic yard for "Remove Sediment".

All costs for furnishing and installing the erosion control wattles including labor, equipment, and materials shall be incidental to the contract unit price per foot for the corresponding erosion control wattle bid item.

All costs for removing the erosion control wattle from the project including labor, equipment, and materials shall be incidental to the contract unit price per foot for "Remove Erosion Control Wattle".

December 23, 2004