

000I-272 MOODY COUNTY FENCE REPLACEMENT LENGTH: 5.000 MILES PCN I2UF

R 50 W

R 49 W

END PROJECT
MRM 116.00 + 0.840
MILEAGE 116.626

T 107 N

BEGIN PROJECT
MRM 111.00 + 0.800
MILEAGE 111.602

STORM WATER PERMIT
(None required)

T 106 N

DESIGN DESIGNATION	
ADT(2011)	6,510
ADT(2031)	7,519
DHV	857.1
D	51%
T DHV	10.3%
T ADT	22.6%
V	75 MPH

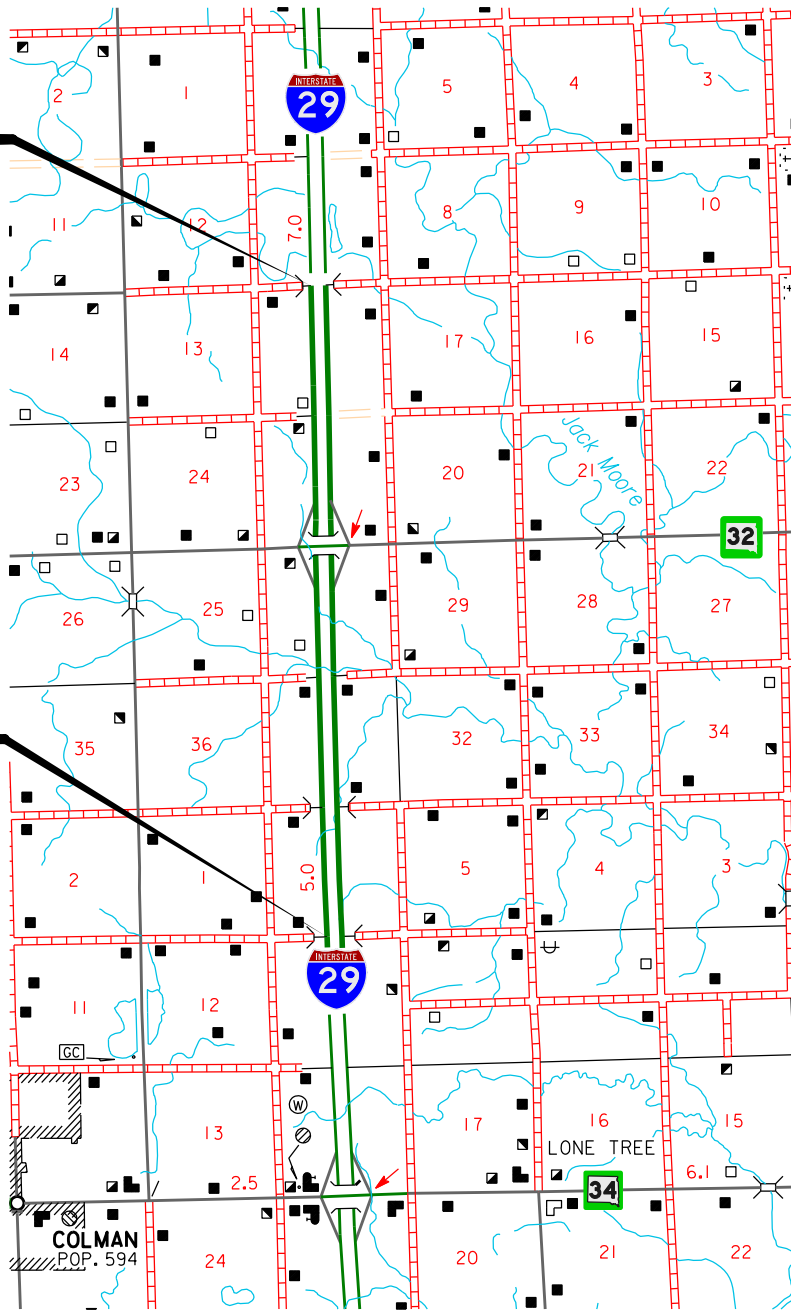

**0001-272
MOODY COUNTY
INDEX OF SHEETS**

Sheet 1	Layout Map
Sheet 2	Index of Sheets
Sheet 3	Estimate of Quantities
Sheet 4	Table of Fence Quantities
Sheets 5 - 7	Plan Notes
Sheet 8	Traffic Control
Sheet 9	Details for Right-of-Way Fence
Sheets 10 - 15	Standard Plates

**0001-272
MOODY COUNTY
ESTIMATE OF QUANTITIES**

Bid Item Number	Item	Quantity	Unit
009E0010	Mobilization	Lump Sum	LS
100E0100	Clearing	Lump Sum	LS
110E0600	Remove Fence	1,169	Ft
620E0030	Type 3 Right-of-Way Fence	1,169	Ft
620E1020	2 Post Panel	19	Each
634E0120	Traffic Control, Miscellaneous	Lump Sum	LS

0001-272
MOODY COUNTY

TABLE OF FENCING QUANTITIES

LANE	INTERSTATE 29 MRM Bridge Locations	REMOVE FENCE FT	TYPE 3 R/W FENCE FT	2 POST PANEL EACH
NB	111.84 S. Side of Structure	74	74	2
NB	111.84 S. Side of Structure (Median)	48	48	-
NB	111.84 N. Side of Structure	80	80	2
NB	111.84 N. Side of Structure (Median)	48	48	-
NB	112.83 S. Side of Structure	70	70	1
NB	112.83 S. Side of Structure (Median)	48	48	-
NB	112.83 N. Side of Structure	75	75	1
NB	112.83 N. Side of Structure (Median)	48	48	-
NB	116.84 S. Side of Structure	75	75	3
NB	116.84 S. Side of Structure (Median)	48	48	-
NB	116.84 N. Side of Structure	75	75	2
NB	116.84 N. Side of Structure (Median)	48	48	-
I29 NBL TOTALS:		737	737	11
SB	111.84 S. Side of Structure	75	75	1
SB	111.84 N. Side of Structure	75	75	1
SB	112.83 S. Side of Structure	69	69	1
SB	112.83 N. Side of Structure	70	70	1
SB	116.84 S. Side of Structure	70	70	2
SB	116.84 N. Side of Structure	73	73	2
I29 SBL TOTALS:		432	432	8
TOTALS:		1169	1169	19

**0001-272
MOODY COUNTY**

SPECIFICATIONS

Standard Specifications for Roads and Bridges, 2004 Edition and Required Provisions, Supplemental Specifications and/or Special Provisions as included in the Proposal.

UTILITIES

The Contractor shall contact the involved utility companies through South Dakota One Call (1-800-781-7474) prior to starting work. It shall be the responsibility of the Contractor to coordinate work with the utility owners to avoid damage to existing facilities.

Utilities are not planned to be affected on this project. If utilities are identified near the improvement area through the SD One Call Process as required by South Dakota Codified Law 49-7A and Administrative Rule Article 20:25, the Contractor shall contact the Project Engineer to determine modifications that will be necessary to avoid utility impacts.

COORDINATION BETWEEN CONTRACTORS

A separate contract for Project P 0022(40)- PCN 03K4 has been awarded to another Contractor for asphalt concrete crack sealing on shoulders on I29 from MRM 110.31 to MRM 121.84.

The Contractor shall schedule his work so as not to interfere with or hinder the progress of the work performed by other Contractors on the asphalt concrete crack sealing project.

HISTORICAL PRESERVATION OFFICE CLEARANCES

To obtain State Historical Preservation Office (SHPO) clearance, a cultural resources survey may need to be conducted by a qualified archaeologist. In lieu of a cultural resources survey, the Contractor could request a records search from Jim Donohue, State Archaeological Research Center (SARC). Provide SARC with the following: a topographical map or aerial view on which the site is clearly outlined, site dimensions, project number, and PCN. If applicable, provide evidence that the site has been previously disturbed by farming, mining, or construction activities with a landowner statement that no artifacts have been found on the site. The Contractor shall arrange and pay for the cultural resource survey and/or records search.

If any earth disturbing activities occur within the current geographical or historic boundaries of any South Dakota reservation, the Contractor shall obtain Tribal Historical Preservation Office (THPO) clearance. If no THPO exists, the required SHPO clearance shall suffice, with documentation of Tribal contact efforts provided to SHPO.

To facilitate SHPO or THPO responses, the Contractor should submit a records search or cultural resources survey report to the DOT Environmental Engineer, 700 East Broadway Avenue, Pierre, SD 57501-2586 (605-773-3268). Allow 30 days from the date this information is submitted to the Environmental Engineer for SHPO/THPO approval. The Contractor is responsible for obtaining all required permits and clearances for staging areas, borrow sites, waste disposal sites, and all material processing sites. The Contractor shall provide the required permits and clearances to the Engineer at the preconstruction meeting.

WASTE DISPOSAL SITE

The Contractor will be required to furnish a site(s) for the disposal of construction/demolition debris generated by this project.

Construction/demolition debris may not be disposed of within the State ROW.

The waste disposal site(s) shall be managed and reclaimed in accordance with the following from the General Permit for Highway, Road, and Railway Construction/Demolition Debris Disposal Under the South Dakota Waste Management Program issued by the Department of Environment and Natural Resources.

The waste disposal site(s) shall not be located in a wetland, within 200 feet of surface water, or in an area that adversely affects wildlife, recreation, aesthetic value of an area, or any threatened or endangered species, as approved by the Engineer.

**0001-272
MOODY COUNTY**

WASTE DISPOSAL SITE (CONTINUED)

If the waste disposal site(s) is located such that it is within view of any ROW, the following additional requirements shall apply:

1. Construction/demolition debris consisting of concrete, asphalt concrete, or other similar materials shall be buried in a trench completely separate from wood debris. The final cover over the construction/demolition debris shall consist of a minimum of 1 foot of soil capable of supporting vegetation. Waste disposal sites provided outside of the State ROW shall be seeded in accordance with Natural Resources Conservation Service recommendations. The seeding recommendations may be obtained through the appropriate County NRCS Office. The Contractor shall control the access to waste disposal sites not within the State ROW through the use of fences, gates, and placement of a sign or signs at the entrance to the site stating "No Dumping Allowed".
2. Concrete and asphalt concrete debris may be stockpiled within view of the ROW for a period of time not to exceed the duration of the project. Prior to project completion, the waste shall be removed from view of the ROW or buried and the waste disposal site reclaimed as noted above.

The above requirements will not apply to waste disposal sites that are covered by an individual solid waste permit as specified in SDCL 34A-6-58, SDCL 34A-6-1.13, and ARSD 74:27:10:06.

Failure to comply with the requirements stated above may result in civil penalties in accordance with South Dakota Solid Waste Law, SDCL 34A-6-1.31.

Cost associated with furnishing waste disposal site(s), disposing of waste, maintaining control of access (fence, gates and signs), and reclamation of the waste disposal site(s) shall be incidental to the various contract items.

RESTORATION OF INSLOPES AND DITCHES

Any slope area or ditch that is rutted or otherwise unduly disturbed during fencing operations shall be restored and seeded by the Contractor, at no expense to the State. Cost for this work shall be incidental to the contract unit prices for the various items.

REMOVE FENCE

The Contractor shall remove the existing right-of-way fence that is to be replaced as designated in the plans and/or as ordered by the Engineer.

Limited Access Security - All fence removed during any one working day is to be replaced during the same day if livestock are being restrained.

CLEARING

Prior to installing right-of-way fence, the fence alignment shall be cleared of all trees, tree branches, tree stumps, brush, vegetation, debris, bladed and leveled to the satisfaction of the Engineer. Sod cleared from the fence alignment may be disposed on the interstate ditch back slope. Lumps or clods over 3 inches in diameter shall be broken up.

Clearing will be paid for at the contract lump sum price. Payment shall be full compensation for labor and equipment necessary to clear the entire line for fence and smooth ground irregularities.

FENCE ALIGNMENT

Where fence is being removed and replaced, fence shall be installed on the same alignment as existing. It shall be the Contractor's responsibility to preserve the fence alignment.

TYPE 3 RIGHT-OF-WAY FENCE

The Contractor shall furnish new posts. Install alternate wood and steel posts at 16'-6" spacing for Type 3 Right-of-Way Fence.

**0001-272
MOODY COUNTY**

NEW POST PANELS

Existing post panels shall be replaced. Existing 5 Post and 4 Post Panels shall be replaced with a combination of 2 Post and 3 Post Panels as determined by the Engineer.

The number of 2 Post and 3 Post Panels will be the actual number installed and will be paid for at the contract unit price per each.

GENERAL MAINTENANCE OF TRAFFIC

Removing, relocating, covering, salvaging and resetting of permanent traffic control devices, including delineation, shall be the responsibility of the Contractor. Cost for this work shall be incidental to the contract unit prices for the various items unless otherwise specified in the plans. Any delineators and signs damaged or lost shall be replaced by the Contractor at no cost to the State.

Storage of vehicles and equipment shall be outside the clear zone and as near as possible to the right-of-way line. Contractor's employees should mobilize at a location off the right-of-way and arrive at the work sites in a minimum number of vehicles necessary to perform the work.

Indiscriminate driving and parking of vehicles within the right-of-way will not be permitted. Any damage to the vegetation, surfacing, embankment, delineators and existing signs resulting from such indiscriminate use shall be repaired and/or restored by the Contractor, at no expense to the State, and to the satisfaction of the Engineer.

The Contractor shall provide documentation that all breakaway sign supports comply with FHWA NCHRP 350 or MASH crash-worthy requirements. The Contractor shall provide installation details at the preconstruction meeting for all breakaway sign support assemblies.

Cost for traffic control, including signs, shall be included in the contract lump sum price for Traffic Control, Miscellaneous.

**0001-272
MOODY COUNTY**

The signs illustrated are not required if the work space is behind a barrier, more than 2 feet behind the curb, or 15 feet or more from the edge of any roadway.

The signs illustrated shall be used where there are distracting situations; such as: vehicles parked on shoulder, vehicles accessing the work site via the highway, and equipment traveling on or crossing the roadway to perform work operations.

The ROAD WORK AHEAD sign may be replaced with other appropriate signs, such as the SHOULDER WORK sign. The SHOULDER WORK sign may be used for work adjacent to the shoulder.

* If the work space is on a divided highway, an advance warning sign should also be placed on the left side of the directional roadway.

For short term, short duration, or mobile operations, all signs and channelizing devices may be eliminated if a vehicle with an activated flashing or revolving yellow light is used.

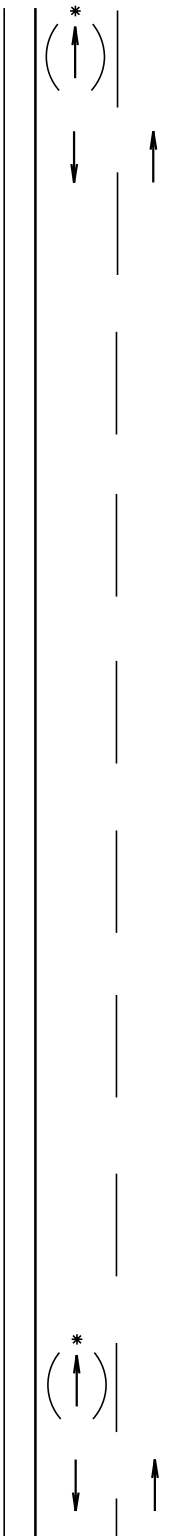

Posted Speed Prior to Work (M.P.H.)	Spacing of Advance Warning Signs (Feet) (A)
0 - 30	200
35 - 40	350
45 - 50	500
55	750
60 - 75	1000

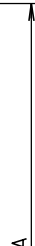

July 1, 2005

<p><i>Published Date: 1st Qtr. 2013</i></p>	<p>S D D O T</p>	<p>GUIDES FOR TRAFFIC CONTROL DEVICES WORK BEYOND THE SHOULDER</p>	<p>PLATE NUMBER 634.01</p>
			<p>Sheet 1 of 1</p>

**0001-272
MOODY COUNTY**

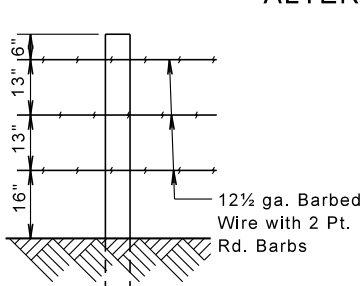
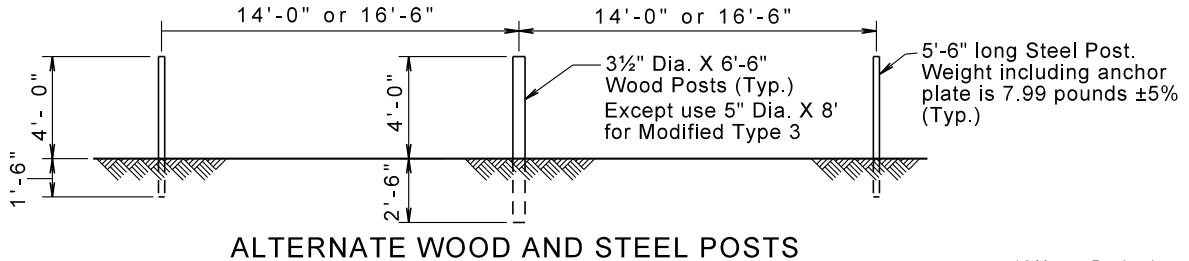
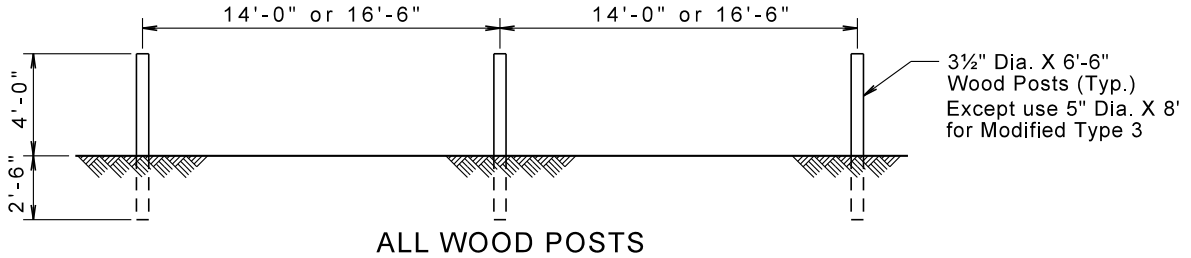

3 BARBED WIRES

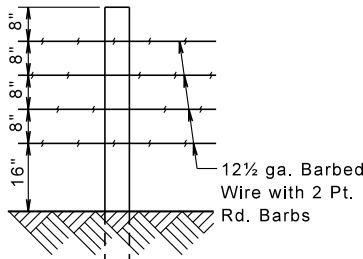

4 BARBED WIRES

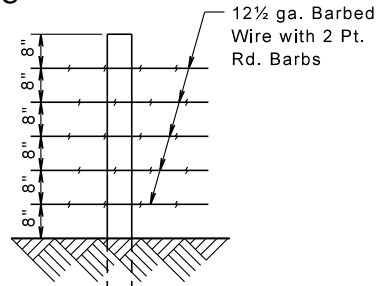

5 BARBED WIRES

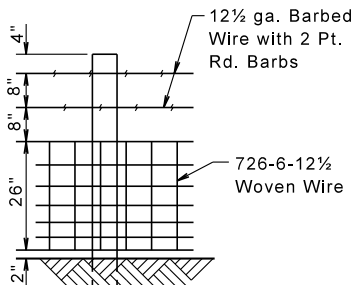

**26" WOVEN WIRE
WITH 2 BARBED WIRES**

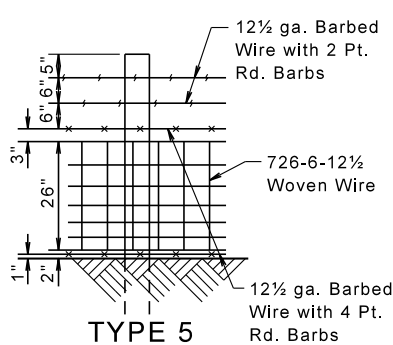

**26" WOVEN WIRE
WITH 4 BARBED WIRES**

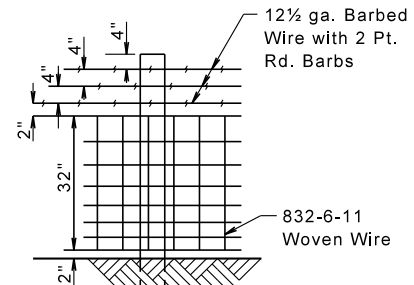

**32" WOVEN WIRE
WITH 3 BARBED WIRES**

TYPE	DESCRIPTION	LINE POST SPACING	BARBED WIRE		WOVEN WIRE
			WIRE GAGE	NUMBER AND SHAPE OF BARBS	STYLE OR DESIGN NO.
1	3 Barbed Wires	16'-6"	12½	2 Point Round	---
2	4 Barbed Wires	16'-6"	12½	2 Point Round	---
3	5 Barbed Wires	16'-6"	12½	2 Point Round	---
MOD3	5 Barbed Wires	14'-0"	12½	2 Point Round	---
4	26" Woven Wire with 2 Barbed Wires	14'-0"	12½	2 Point Round	726-6-12½
5	26" Woven Wire with 4 Barbed Wires	14'-0"	12½	2 wires with 2 Pt. Rd., 2 wires with 4 Pt. Rd.	726-6-12½
MOD6	32" Woven Wire with 3 Barbed Wires	14'-0"	12½	3 wires with 2 Pt. Rd.	832-6-11

GENERAL NOTES:

Fence types designated on the plans that are followed by the letter S shall have smooth (barbless) wires.

When type 5S or 6S is designated the bottom wire may be barbed, smooth, or left off.

All degrees of curvature stated for fence are at centerline of roadway.

RIGHT-OF-WAY FENCE

**0001-272
MOODY COUNTY**

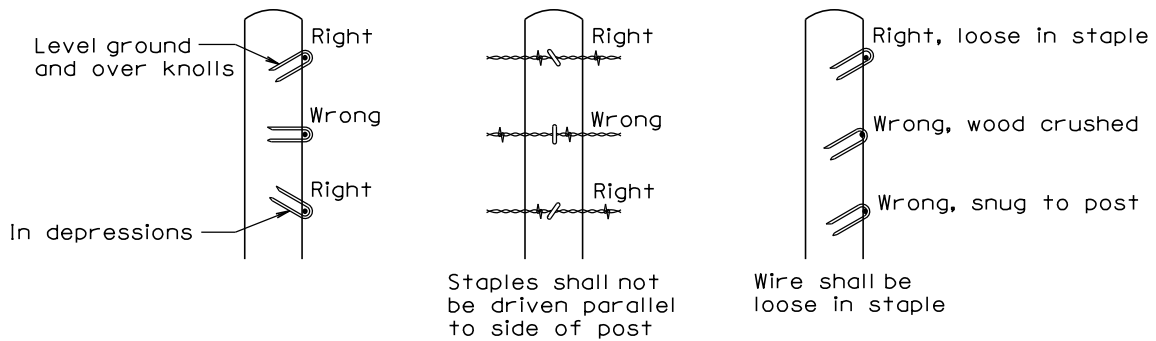

STAPLE INSTALLATION

GENERAL NOTES:

The Right-of-Way fence shall consist of barbed wire or a combination of woven wire and barbed wire. The barbed wire and/or woven wire shall be fastened to all wood posts or fastened to alternating wood and steel posts. Only wood posts shall be used for brace panels. Gates shall be of the type designated in the plans or as otherwise directed by the Engineer. Fence shall be constructed conforming to the details on the standard plates and in the plans unless otherwise directed by the Engineer.

Right-of-Way fence on Interstate Projects shall be constructed one foot within the Interstate Right-of-Way lines except at bridge openings, cattle passes, and as otherwise directed by the Engineer.

Right-of-Way fence other than on Interstate Projects shall be constructed within one foot of the Right-of-Way on the Landowner's side except at bridge openings, cattle passes, and as otherwise directed by the Engineer.

Barbs shall be fabricated from zinc coated 14 ga. wire. Two point barbs shall be wrapped twice around one main strand at 4" spacings and the four point barbs shall be interlocked and wrapped around both main strands at 5" spacings.

The gages of wire and wood post lengths and sizes are the minimum acceptable unless otherwise specified in the plans. The tolerances for steel posts shall be as stated in AASHTO M281. Woven wire shall conform to design and specifications of ASTM A116 and barbed wire shall conform to ASTM A121.

December 23, 2004

<i>Published Date: 1st Qtr. 2013</i>	S D D O T	STAPLE INSTALLATION AND GENERAL RIGHT-OF-WAY FENCE NOTES	PLATE NUMBER 620.02
			Sheet 1 of 1

**0001-272
MOODY COUNTY**

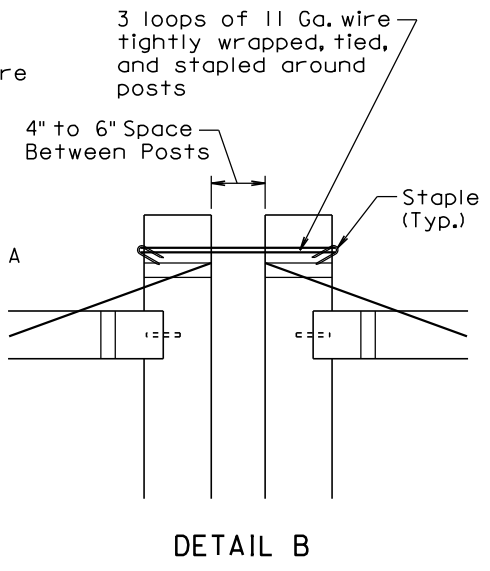
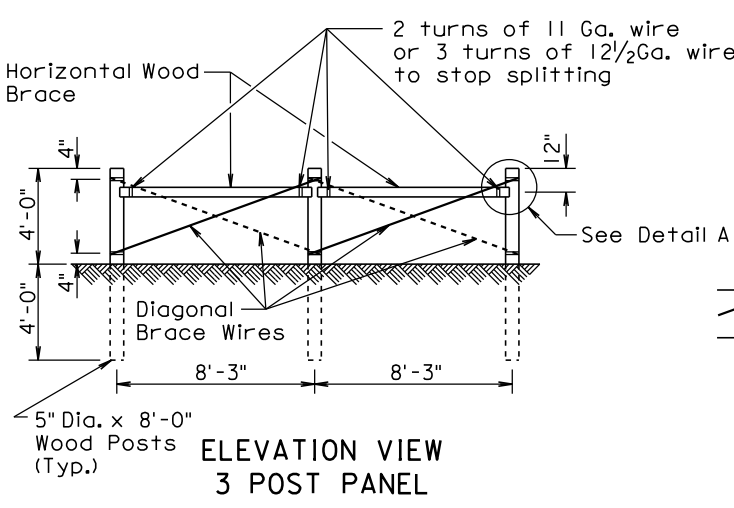
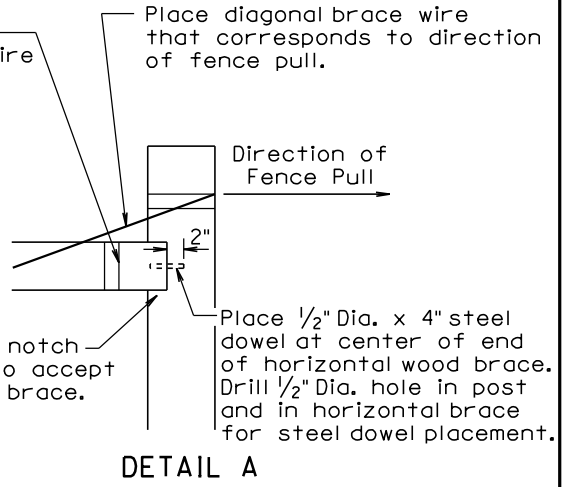
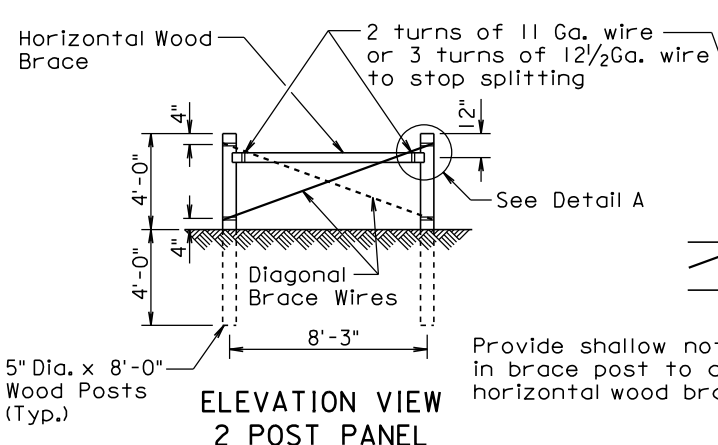

GENERAL NOTES:

- Two Post Panels shall be installed at least every 1320' between corners.
- Two Post Panels shall be installed at any sharp vertical angle crest points and as directed by the Engineer.
- Horizontal wood braces shall consist of 4" dia. x 8' wood posts or rough 4" x 4" x 8' timbers.
- Diagonal brace wires shall be fabricated with 4 strands of 9 Ga. galvanized wire twisted tight. The diagonal brace wires shall be installed in accordance with the direction of the fence pull. Two diagonal brace wires are required if fence pull is in both directions.

December 23, 2004

<i>Published Date: 1st Qtr. 2013</i>	S D D O T	BRACE PANELS AND APPLICATIONS OF BRACE PANELS	PLATE NUMBER 620.03
			Sheet 1 of 3

**0001-272
MOODY COUNTY**

SPACING OF 2 POST PANELS WITHIN CURVES	
DEGREE OF CURVE	SPACING OF 2 POST PANEL
less than 3°15'	** 1320'
3°15' and greater	***At P.C., P.T., and at every 1320' between P.C. and P.T.

GENERAL NOTE:

All degrees of curvature stated for fence are at centerline of roadway.

- * If fence length is less than 600' to next corner use a 2 post panel.
- * If fence length is greater than 600' to next corner use a 3 post panel.

- ** Fence lengths greater than 1320' and less than 2640' place 2 Post Panel approximately at midpoint.

① See Detail B on Sheet 1 of 3.

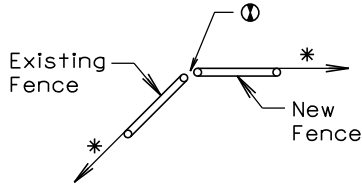

BEGIN OR END FENCE
(where new fence ties into existing fence)

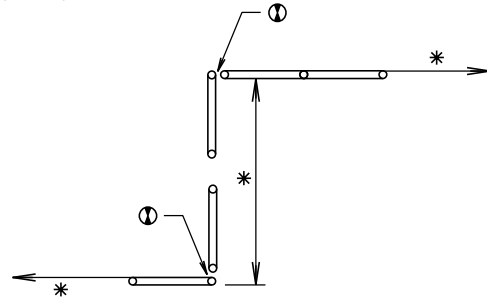
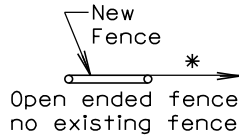

SHORT JOGS IN FENCE

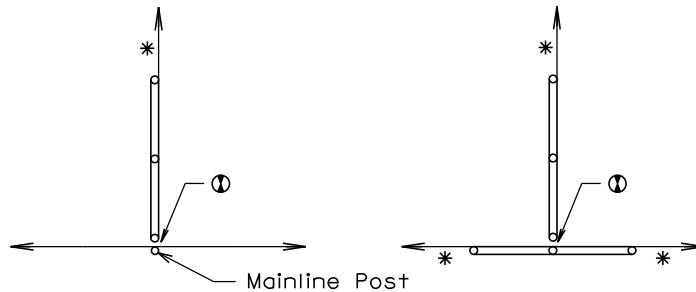

CROSS FENCE

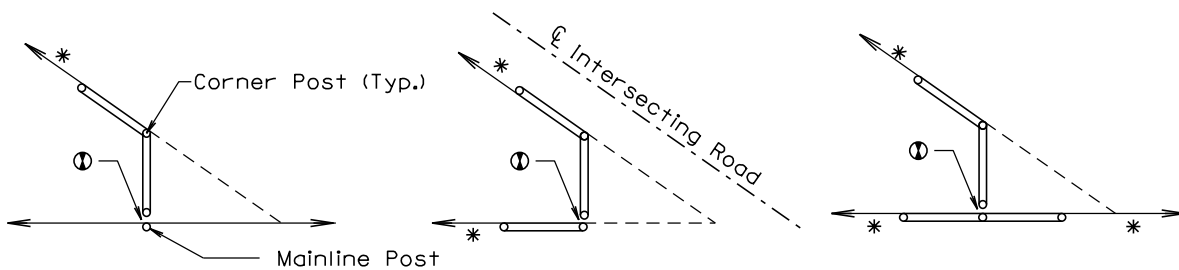

SHARP ANGLES IN CROSS FENCE

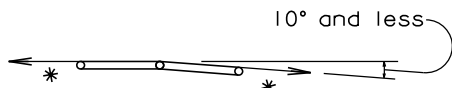

Additional fence panel is NOT required when an angle in the mainline fence is 10° and less.

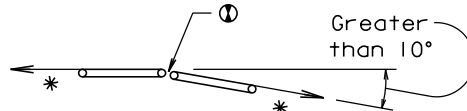

Additional fence panel is required when an angle in the mainline fence is greater than 10°.

ANGLES IN MAINLINE FENCE

December 23, 2004

Published Date: 1st Qtr. 2013

**S
D
D
O
T**

**BRACE PANELS
AND APPLICATIONS OF BRACE PANELS**

PLATE NUMBER
620.03

Sheet 2 of 3

0001-272
MOODY COUNTY

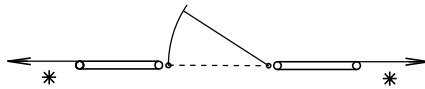

ENTRANCE
(NOT ON CORNER)

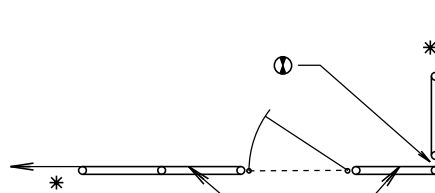
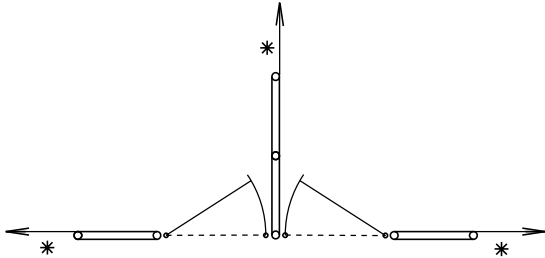

Fence type shall be same as adjacent
fence type or as directed by the Engineer.

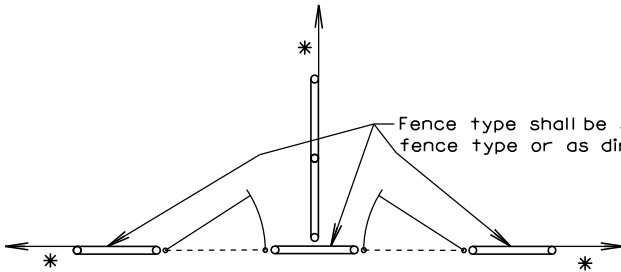
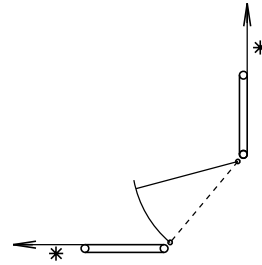
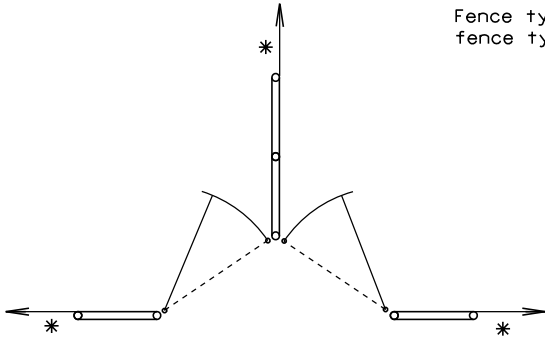

Fence type shall be same as adjacent
fence type or as directed by the Engineer.

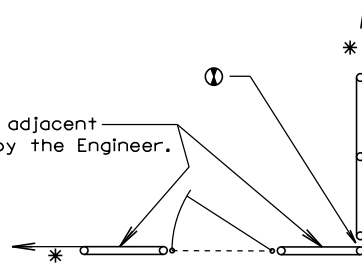

DOUBLE ENTRANCES

ENTRANCES AT CORNERS

GATES

* If fence length is less than 600' to next corner use a 2 post panel.
If fence length is greater than 600' to next corner use a 3 post panel.

① See Detail B on Sheet 1 of 3.

December 23, 2004

Published Date: 1st Qtr. 2013

S
D
D
O
T

BRACE PANELS
AND APPLICATIONS OF BRACE PANELS

PLATE NUMBER
620.03

Sheet 3 of 3

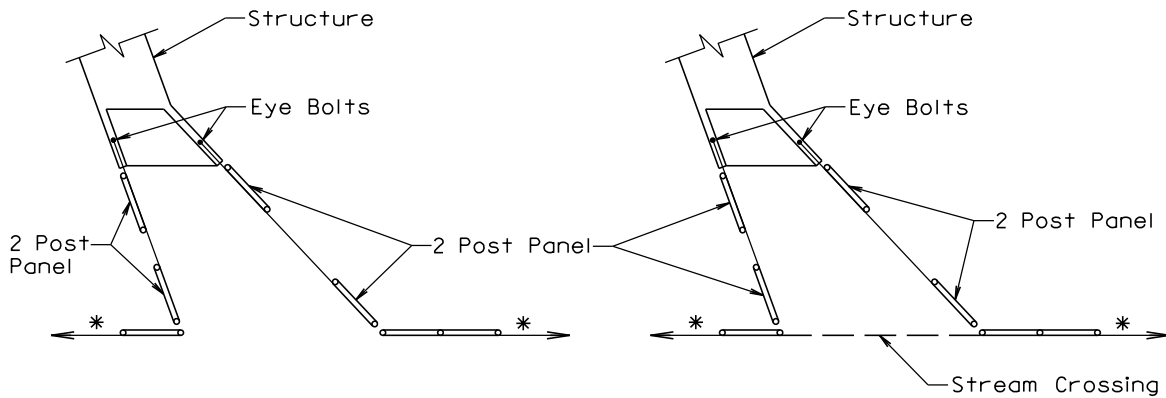

R.C. BOX CULVERT
OR CATTLE PASS

STRUCTURE WITH STREAM
CROSSING FENCE

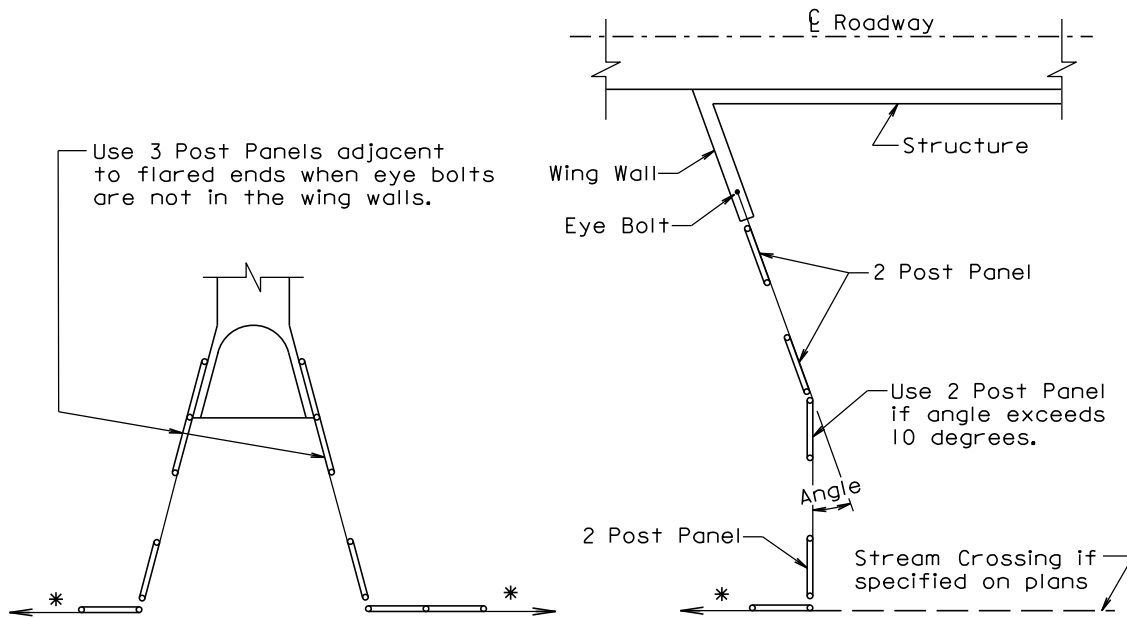

R.C. BOX CULVERT
OR CATTLE PASS

BRIDGE

* If fence length is less than 600' to next corner use a 2 post panel.
* If fence length is greater than 600' use a 3 post panel.

December 23, 2010

Published Date: 1st Qtr. 2013

**S
D
D
O
T**

BRACE PANEL APPLICATIONS AT STRUCTURES

PLATE NUMBER
620.04

Sheet 1 of 1

0001-272
MOODY COUNTY

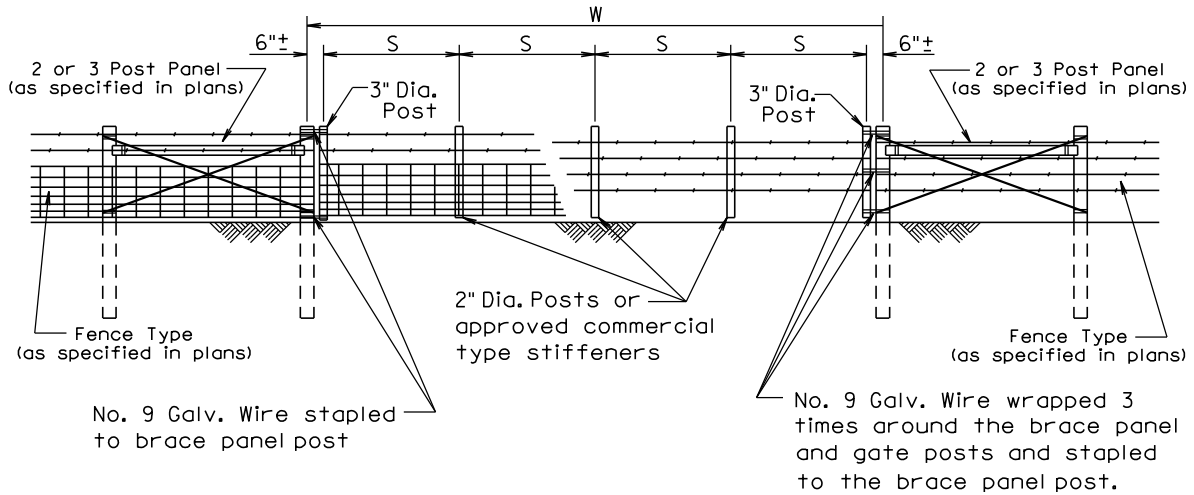

W Gate Width (ft.)	S Post Spacing
16	3 @ 5'-0" ±
20	4 @ 4'-9" ±
24	4 @ 5'-9" ±
30	5 @ 5'-10" ±
40	6 @ 6'-6" ±

GENERAL NOTES:

Creosote treatment of the gate posts will not be accepted.

The type of fencing in the gate shall be of the same type as specified for the adjacent Right-of-Way fence.

All costs for furnishing and constructing the wire gate(s) shall be incidental to the contract unit price per Ft for the respective Right-of-Way fence bid item.

March 31, 2000

Published Date: 1st Qtr. 2013

**S
D
D
O
T**

WIRE GATES

**PLATE NUMBER
620.20**

Sheet 1 of 1