

**GUARDRAIL REPAIR
000I-271, 000I-272, 000I-291 & 000P-292
BON HOMME, CHARLES MIX, CLAY, HUTCHINSON, LAKE,
LINCOLN, MINER, MINNEHAHA, MOODY, TURNER,
UNION & YANKTON COUNTIES
PCN I35Y, I36A, I36C & I36D**



**000I-271, 000I-272, 000I-291 & 000P-292 - GUARDRAIL REPAIR
BON HOMME, CHARLES MIX, CLAY, HUTCHINSON, LAKE, LINCOLN, MINER,
MINNEHAHA, MOODY, TURNER, UNION & YANKTON COUNTIES**

INDEX OF SHEETS

| | |
|----------------|---|
| Sheet 1 | Layout Map |
| Sheet 2 | Index of Sheets |
| Sheet 3 | Estimate of Quantities |
| Sheets 4 - 8 | Plan Notes |
| Sheets 9 - 15 | Traffic Control |
| Sheets 16 - 27 | Standard Plates for Cable Guardrail |
| Sheets 28 - 54 | Standard Plates for Beam Guardrail |
| Sheets 55 - 58 | Standard Plates for Guardrail Delineation |

**000I-271, 000I-272, 000I-291 & 000P-292 - GUARDRAIL REPAIR
 BON HOMME, CHARLES MIX, CLAY, HUTCHINSON, LAKE, LINCOLN, MINER,
 MINNEHAHA, MOODY, TURNER, UNION & YANKTON COUNTIES**

ESTIMATE OF QUANTITIES

| BID ITEM NUMBER | ITEM | | 000I-271 | 000I-272 | 000I-291 | 000P-292 | TOTAL | |
|--------------------|--|----------------------------|------------------------|----------------------|----------------------|----------------------|----------|------|
| | | | PCN I35Y QUANTITY | PCN I36A QUANTITY | PCN I36C QUANTITY | PCN I36D QUANTITY | QUANTITY | UNIT |
| 009E0197 | Mobilization 1 | (Unit 271) | 15 | - | - | - | 15 | Each |
| 009E0198 | Mobilization 2 | (Unit 272) | - | 10 | - | - | 10 | Each |
| 009E0199 | Mobilization 3 | (Unit 291) | - | - | 5 | - | 5 | Each |
| 009E0199 | Mobilization 3 | (Unit 292) | - | - | - | 5 | 5 | Each |
| 120E0600 | Contractor Furnished Borrow | | 40 | 20 | 20 | 20 | 100 | CuYd |
| 628E1520 | Refurbish Concrete Barrier End Protection | | <----- 3 -----> | | | | 3 | Each |
| 629E0100 | 3 Cable Guardrail | | 75 | 50 | 50 | 50 | 225 | Ft |
| 629E0300 | 3 Cable Guardrail Slip Base Anchor Assembly | | <----- 1 -----> | | | | 1 | Each |
| 629E0400 | 3 Cable Guardrail Anchor Assembly | | <----- 1 -----> | | | | 1 | Each |
| 629E0450 | Retension 3 Cable Guardrail | | 75 | 25 | 25 | 25 | 150 | Each |
| 629E1000 | Repair 3 Cable Guardrail | | 9000 | 5000 | 3000 | 3000 | 20000 | Ft |
| 629E1010 | Repair 3 Cable Guardrail Slip Base Anchor Assembly | | <----- 1 -----> | | | | 1 | Each |
| 629E1100 | 3 Cable Guardrail End Post | (I Beam) | 25 | 15 | 10 | 10 | 60 | Each |
| 629E1102 | 3 Cable Guardrail Intermediate Post | (Flanged) | 400 | 200 | 150 | 150 | 900 | Each |
| 629E1102 | 3 Cable Guardrail Intermediate Post | (I Beam) | 40 | 20 | 20 | 20 | 100 | Each |
| 629E1103 | 3 Cable Guardrail Slip Base Anchor Post | | 3 | 2 | 2 | 1 | 8 | Each |
| 629E1104 | 3 Cable Guardrail Post, Winter | | 350 | 150 | 100 | 100 | 700 | Each |
| 629E1106 | Drive Down 3 Cable Guardrail Post | | 7 | 3 | 3 | 2 | 15 | Each |
| 629E1108 | Reset 3 Cable Guardrail Post | | 75 | 40 | 30 | 30 | 175 | Each |
| 629E1110 | Cable Anchor Bracket | | 1 | 1 | 1 | 1 | 4 | Each |
| 629E1112 | Cable Splice | | 4 | 2 | 2 | 2 | 10 | Each |
| 629E1114 | 3 Cable Guardrail J Hook Bolt | | 1400 | 700 | 700 | 700 | 3500 | Each |
| 629E1116 | Steel Turnbuckle Cable End Assembly | | 12 | 6 | 6 | 6 | 30 | Each |
| 629E1118 | Spring Cable End Assembly with Turnbuckle | | 12 | 6 | 6 | 6 | 30 | Each |
| 629E1120 | W Beam to 3 Cable Transition Bracket | | 8 | 4 | 4 | 4 | 20 | Each |
| 629E1122 | 3 Cable Guardrail End Post Cap | | 1 | 1 | 1 | 1 | 4 | Each |
| 630E0200 | Straight Class A Thrie Beam Rail | (12 Gauge) | 12.5 | 12.5 | 12.5 | 12.5 | 50 | Ft |
| 630E0210 | Straight Class B Thrie Beam Rail | (10 Gauge) | 7 | 7 | 6 | 5 | 25 | Ft |
| 630E1200 | Straight Class A W Beam Rail | (12 Gauge) | 250 | 150 | 125 | 125 | 650 | Ft |
| 630E1210 | Straight Class B W Beam Rail | (10 Gauge) | 12.5 | 12.5 | 12.5 | 12.5 | 50 | Ft |
| 630E2000 | W Beam to Thrie Beam Guardrail Transition | (6.25') | <----- 2 -----> | | | | 2 | Each |
| 630E2015 | W Beam Guardrail Flared End Terminal | | <----- 1 -----> | | | | 1 | Each |
| 630E2020 | W Beam Guardrail Tangent End Terminal | | <----- 1 -----> | | | | 1 | Each |
| 630E2030 | W Beam Guardrail Breakaway Cable Terminal | | 2 | 1 | 1 | 1 | 5 | Each |
| 630E2050 | Beam Guardrail Trailing End Terminal | (W or Thrie) | <----- 1 -----> | | | | 1 | Each |
| 630E2100 | Beam Guardrail Post | (6" x 8" x 6', 6.5' or 7') | 4 | 2 | 2 | 2 | 10 | Each |
| 630E2105 | Beam Guardrail Block | (6" x 8" x 14" or 22.5") | 4 | 2 | 2 | 2 | 10 | Each |
| 630E2110 | Beam Guardrail Post and Block | (6', 6.5' or 7' Post) | 40 | 20 | 15 | 15 | 90 | Each |
| 630E2120 | Beam Guardrail Post and Block, Winter | | 20 | 10 | 10 | 10 | 50 | Each |
| 630E2150 | End Terminal Wood Breakaway Post | | 2 | 2 | 2 | 2 | 8 | Each |
| 630E2155 | End Terminal Hinged Breakaway Post | | 1 | 1 | 1 | 1 | 4 | Each |
| 630E2210 | Breakaway Cable Terminal End Rail | | 1 | 1 | 1 | 1 | 4 | Each |
| 630E2215 | W Beam Guardrail End Section Buffer | | 4 | 2 | 2 | 2 | 10 | Each |
| 630E2220 | Tangent End Terminal Extruder Head | | <----- 2 -----> | | | | 2 | Each |
| 630E2235 | Tangent End Terminal Rail | | <----- 50 -----> | | | | 50 | Ft |
| 630E2300 | Rubrail | | <----- 14 -----> | | | | 14 | Ft |
| 630E5520 | Drive Down Beam Guardrail Post | | 2 | 2 | 2 | 2 | 8 | Each |
| 630E5550 | Reset Beam Guardrail Post and Block | | 15 | 5 | 5 | 5 | 30 | Each |
| 632E2220 | Guardrail Delineator | | 125 | 75 | 75 | 75 | 350 | Each |
| 632E2510 | Type 2 Object Marker Back to Back | | 12 | 12 | 8 | 8 | 40 | Each |
| 632E2520 | Type 2 Object Marker | | 20 | 20 | 15 | 15 | 70 | Each |
| 634E0010 | Flagging | | 3 | 1 | 1 | 1 | 6 | Hour |
| 634E0100 | Traffic Control | | 172 | 90 | 90 | 90 | 442 | Unit |
| 634E0120 | Traffic Control, Miscellaneous | | <----- Lump Sum -----> | | | | Lump Sum | LS |
| 634E0420 | Type C Advance Warning Arrow Panel | | <----- 1 -----> | | | | 1 | Each |

**000I-271, 000I-272, 000I-291 & 000P-292 - GUARDRAIL REPAIR
BON HOMME, CHARLES MIX, CLAY, HUTCHINSON, LAKE, LINCOLN, MINER,
MINNEHAHA, MOODY, TURNER, UNION & YANKTON COUNTIES**

SPECIFICATIONS

Standard Specifications for Roads and Bridges, 2004 Edition and Required Provisions, Supplemental Specifications and/or Special Provisions as included in the proposal.

LOCATION

Guardrail repair will be limited to all Interstate and State Highways within the Sioux Falls and Yankton Areas.

ESTIMATED QUANTITIES

The Contractor shall furnish and install new guardrail material as per the Contract Proposal. The quantities for each item are estimated. The actual amount of work required may vary greatly from the Estimate of Quantities. There will be NO negotiation for overruns or underruns on this contract.

MOBILIZATION

Mobilization 1 (Unit 271) - is the cost for mobilization per each time the Contractor is called in by the Area Engineer to perform guardrail repair within the Sioux Falls Area - Unit 271.

Mobilization 2 (Unit 272) - is the cost for mobilization per each time the Contractor is called in by the Area Engineer to perform guardrail repair within the Sioux Falls Area - Unit 272.

Mobilization 3 (Unit 291) - is the cost for mobilization per each time the Contractor is called in by the Area Engineer to perform guardrail repair within the Yankton Area - Unit 291.

Mobilization 3 (Unit 292) - is the cost for mobilization per each time the Contractor is called in by the Area Engineer to perform guardrail repair within the Yankton Area – Unit 292.

The maximum allowable contract unit price submitted for Mobilization 1 (Unit 271), Mobilization 2 (Unit 272), Mobilization 3 (Unit 291) or Mobilization 3 (Unit 292) shall not exceed \$1500.

Mobilization 1 (Unit 271), Mobilization 2 (Unit 272), Mobilization 3 (Unit 291) or Mobilization 3 (Unit 292) will be paid for once each time the Contractor is called to the Unit, regardless of the number of sites requiring repair within that Unit.

EMBANKMENT AND SURFACING FOR GUARDRAIL INSTALLATIONS

When a guardrail end terminal is ordered to be repaired, and the new end terminal installation requires embankment and surfacing modification, payment will be made at contract unit prices for Contractor Furnished Borrow for the fill material.

It is not anticipated that surfacing will be required as a part of this contract. However, if surfacing material (base material and/or asphalt concrete) is required, it will be:

1. Furnished by the State and a placement price will be negotiated, or
2. Furnished and placed by the Contractor and a price will be negotiated, or
3. It will be accomplished by other means approved by the Engineer.

CONTRACTOR FURNISHED BORROW

The Contractor may be required to furnish borrow material on this project. When borrow material is required it shall be furnished in accordance with the Standard Specifications.

RESTORATION OF DISTURBED AREAS

Areas disturbed as a result of work necessary under this Contract shall be reshaped and/or restored to the satisfaction of the Engineer.

Slopes and berms disturbed shall be leveled, excess material removed, area tilled to the minimum depth of three inches, seeded with Intermediate Wheatgrass at the rate of 18 Pounds P.L.S. per acre and fertilized with a commercial fertilizer with a minimum guaranteed analysis of 18-46-0 applied at the rate of 100 pounds per acre.

Cost for reshaping, leveling, removal of excess material, tilling, seeding and fertilizing disturbed areas on the slopes and berms shall be incidental to the contract unit prices for the various items.

**000I-271, 000I-272, 000I-291 & 000P-292 - GUARDRAIL REPAIR
BON HOMME, CHARLES MIX, CLAY, HUTCHINSON, LAKE, LINCOLN, MINER,
MINNEHAHA, MOODY, TURNER, UNION & YANKTON COUNTIES**

GUARDRAIL COMPLETION REQUIREMENTS

At such time as repairs are required, the Contractor will be notified. The Contractor will have 21 days to complete the repairs. In the event that the Contractor has other guardrail work scheduled on another South Dakota State contract, the Contractor may contact the Engineer to work out a reasonable schedule to accomplish the work. The Engineer will consider extending the completion time based on traffic volume, possible accident severity and probability.

Once the existing guardrail is removed from any item of concern (bridge end, box culvert, bridge column, etc.), the Contractor shall place drums or Type II Barricades at 25 foot intervals at each location where existing guardrail is removed. These devices shall extend 175 feet beyond the item of concern for each direction of traffic. Drums or Barricades shall remain in place until new guardrail has been installed. Cost for furnishing, installing and maintaining drums or barricades shall be incidental to the contract lump sum price for Traffic Control Miscellaneous.

Post end, beam, and end terminal sections shall be erected in a continuous operation within each individual run of guardrail. Incomplete guardrail installations shall be marked by delineation as noted in the previous paragraph.

If the Contractor fails to complete the required work within the time allowed, the Contractor shall install an approved safety treatment that complies with NCHRP 350, level 3, to protect the site.

Failure to comply with this requirement will necessitate liquidated damages being assessed at a rate of \$500 for each calendar day that the guardrail work remains incomplete for the item of concern. This provision applies up to the contract completion date. After the contract completion date, liquidated damages will be assessed in accordance with Section 8.7 or \$500, whichever is greater.

GUARDRAIL

- A. Should some guardrail items be required that are not in the Contract Proposal, the Contractor shall furnish the items and will be paid invoice cost plus shipping, taxes and ten percent for profit. Prior approval of the Engineer will be required for these purchases. Installation cost for these items shall be incidental to the contract unit prices for the various items.

Contract unit prices for the various Beam Guardrail Post and Block items shall include the appropriate size wood block.

Cost to furnish and install new bolts, nuts, washers, nails, misc. shall be incidental to the contract unit prices for the various items.

Cost to remove and dispose of guardrail items shall be incidental to the contract unit prices for the various items.

- B. Removed guardrail items that are not reused shall become the property of the Contractor.
- C. Beam Guardrail Post and Block, Winter - Includes the additional cost for removal and installation of wood posts and blocks when there is in excess of one foot of solid frozen ground at the work site. This contract unit price will be an additional payment for each post and block installed under these conditions.
- D. Drive Down Beam Guardrail Post - Includes the cost for adjusting the height of a beam guardrail post. Cost for disassembly/reassembly of the beam guardrail necessary to perform this adjustment shall be incidental to the contract unit price for this item.
- E. Reset Beam Guardrail Post and Block - Includes removing and resetting wood guardrail post and block to the proper alignment with existing beam guardrail. Payment will be the same in frozen or unfrozen ground.
- F. Outside Shoulder Installations - Whenever an outside shoulder beam end terminal is significantly damaged, the entire end terminal (25' to 50') shall be removed and replaced with an approved end terminal from the SDDOT Approved List of W Beam Guardrail Terminals. The Contractor may select from any of the terminals specified. Installation of these terminals shall be as per Standard Plate Nos. 630.45 and/or 630.46.

**000I-271, 000I-272, 000I-291 & 000P-292 - GUARDRAIL REPAIR
BON HOMME, CHARLES MIX, CLAY, HUTCHINSON, LAKE, LINCOLN, MINER,
MINNEHAHA, MOODY, TURNER, UNION & YANKTON COUNTIES**

GUARDRAIL (CONTINUED)

- G. Median Installations at Twin Bridges – Whenever a median beam end terminal is significantly damaged, the entire length of beam guardrail (except for the 43.75' closest to the bridge, if this portion of the guardrail is not damaged) shall be replaced as per Standard Plate No. 630.99. This may involve cutting the existing guardrail. Whether the existing installation is W Beam or Thrie/W Beam, the total length of the newly completed installation shall be 81.25'.

At full roadway width bridges the beam and cable guardrail shall be flared at a 16:1 flare rate. At narrow bridges the beam and cable shall be flared at a flare rate (no sharper than 32:1) that will locate the last post of the 100' W Beam to 3 Cable Transition on the shoulder line. From this point the guardrail shall be flared at a 16:1 flare rate out to the end of the 3 Cable Guardrail Slip Base Anchor Assembly. The length of 3 Cable Guardrail beyond the 100' W Beam 3 Cable Transition shall be 195' (12 spaces at 16' plus 3' across the Slip Base).

When an obsolete median installation is replaced with the above standard, the existing guardrail (if present) in the median, protecting the opposite direction traffic from the back of obsolete guardrail, shall be removed.

The entire beam portion of the guardrail shall be installed within the allotted time as described in the Guardrail Completion Requirement notes. The cable portion may be installed in early spring after the ground has thawed, however, the Department, for safety, may order installation of the cable portion within the allotted time as described in the Guardrail Completion Requirements notes.

- H. If the ground condition at the site is frozen or has large snow amounts, then the portion of embankment and surfacing modification that does not affect guardrail installation may be done the following spring.

- I. SDDOT Approved List of W Beam Guardrail Terminals:

Product Name:

- **ET-2000 (Tangent Terminal)**
- **SRT-350 (Flared Terminal)**

Produced By:

SYRO, Inc., a Trinity Industries Co.
2525 Stemmons Freeway
Dallas, Texas 75207
1-800-644-7976 (214) 589-8814
Fax: (214) 589-8423

- **SKT 350 (Tangent Terminal)**
- **FLEAT 350 (Flared Terminal)**

Road Systems, Inc.
1507 East 4th Street
Big Spring, Texas 79720
(915) 263-2435
Fax: (915) 267-4039

- J. End Terminal Wood Breakaway Post – Includes the cost to remove the existing and install a new wood breakaway post on an end terminal.

End Terminal Hinged Breakaway Post – Includes the cost to remove the existing and install a new breakaway post on an end terminal.

Tangent End Terminal Extruder Head – Includes the cost to remove the existing and install a new Tangent End Terminal Extruder Head on a tangent end terminal.

Tangent End Terminal Rail – Includes the cost to remove existing and install new beam guardrail on a tangent end terminal.

- K. W Beam Guardrail Breakaway Cable Terminal – Includes the cost for removing damaged components of the existing terminal (including rail), furnishing and installing new Wood Breakaway End Posts (2), W Beam End Section (Buffer) 11" +/- radius, the Modified W Beam Connector, related items and all hardware to attach. Any other BCT items that are required will be paid for at invoice cost plus shipping, taxes and ten percent profit (labor will be incidental to other items). The BCT will only be installed at locations where a W Beam to 3 Cable Transition is required.

Breakaway Cable Terminal End Rail – Includes the cost to remove the existing and install a new end rail.

W Beam Guardrail End Section Buffer – Includes the cost to remove the existing and install a new buffer assembly.

**000I-271, 000I-272, 000I-291 & 000P-292 - GUARDRAIL REPAIR
BON HOMME, CHARLES MIX, CLAY, HUTCHINSON, LAKE, LINCOLN, MINER,
MINNEHAHA, MOODY, TURNER, UNION & YANKTON COUNTIES**

GUARDRAIL (CONTINUED)

- L. 3 Cable Guardrail Post, Winter - Includes the additional cost for removal and installation of 3 Cable Guardrail Posts (I Beam and Flanged Channel) when there is in excess of one foot of solid frozen ground at the work site. This contract unit price will be an additional payment for each post installed under these conditions.
- M. Drive Down 3 Cable Guardrail Post - Includes the cost for adjusting the height of a cable guardrail post. Cost for disassembly/reassembly of the cable guardrail necessary to perform this adjustment shall be incidental to the contract unit price for this item.
- N. Reset 3 Cable Guardrail Post - Includes removing and resetting cable guardrail post to the proper alignment with existing cable guardrail. Payment will be the same in frozen or unfrozen ground.
- O. Repair 3 Cable Guardrail - Includes the cost for putting existing 3 cable guardrail back into its original position and, if required, realigning posts within the displaced length of three cable guardrail. Payment for this item is applicable only when the existing cable rail requires being put back in place and posts require realigning. Payment length shall be:
- From the first existing post that does not need replacing on each end of the repair area,
 - From the first existing post that does not need replacing to the anchor if the anchor post, end posts or transition bracket are replaced or,
 - From the first existing post that does not need replacing to the transition bracket if the transition bracket is not replaced.

If multiple areas require repair within a cable installation, the areas shall be measured separately.

- P. Retension 3 Cable Guardrail – Includes the cost for tensioning of the entire run of three cable guardrail. Payment will be made once per each installation retensioned, regardless of whether one, two or all three cables require retensioning.
- Q. Repair 3 Cable Guardrail Slip Base Anchor Assembly - This item will be considered full compensation for removal, repair and replacement of the damaged Slip Base Anchor Assembly. This work will be performed if it is determined that the Slip Base Anchor Assembly can be repaired without total footing removal. The work will consist of coring a 12" diameter section into the existing footing, centered over the existing slip base anchor stub post, to a depth of 22". The core will then be broke off and disposed of. The sides of the hole in the footing shall be roughened to the satisfaction of the Engineer. A rapid-setting, non-shrink, non-metallic grout shall be used (in accordance with the manufacturer's recommendations) to anchor the new slip base anchor stub post in the footing. The grout shall reach a compressive strength of over 5000 PSI.
- R. Refurbish Concrete Barrier End Protection - This item will be considered full compensation for removal, repair and replacement of the damaged Tracc Barrier Protection System. The Contractor will load and transport the Tracc system stored at the Sioux Falls Area Office Complex to the accident site. The in place damaged Tracc system will be removed and replaced with the unit from the Sioux Falls Area Complex. The damaged unit will be rebuilt in accordance with the manufacturer's instructions at the Contractor's shop. After being rebuilt the Contractor shall then transport it to the Sioux Falls Area Complex for future use.

**000I-271, 000I-272, 000I-291 & 000P-292 - GUARDRAIL REPAIR
BON HOMME, CHARLES MIX, CLAY, HUTCHINSON, LAKE, LINCOLN, MINER,
MINNEHAHA, MOODY, TURNER, UNION & YANKTON COUNTIES**

GUARDRAIL DELINEATION

Whenever the Contractor is directed to perform guardrail repair, all of the guardrail delineation at the location will be considered for upgrade. This will typically involve guardrail delineation at two to eight guardrail runs (For example: At twin structures, if one guardrail run is damaged, and the existing guardrail delineation at the site is not at the current standard, then all of the substandard guardrail delineation at each guardrail run (all traffic directions, over and under) will be upgraded).

Cost for this work shall be included in the contract unit prices per each for Guardrail Delineator, Type 2 Object Marker Back to Back, and Type 2 Object Marker.

GENERAL MAINTENANCE OF TRAFFIC

Removing, relocating, covering, salvaging and resetting of permanent traffic control devices, including delineation, shall be the responsibility of the Contractor. Cost for this work shall be incidental to the contract unit prices for the various items unless otherwise specified in the plans. Any delineators and signs damaged or lost shall be replaced by the Contractor at no cost to the State.

Storage of vehicles and equipment shall be outside the clear zone and as near as possible to the right-of-way line. Contractor's employees should mobilize at a location off the right-of-way and arrive at the work sites in a minimum number of vehicles necessary to perform the work.

Indiscriminate driving and parking of vehicles within the right-of-way will not be permitted. Any damage to the vegetation, surfacing, embankment, delineators and existing signs resulting from such indiscriminate use shall be repaired and/or restored by the Contractor, at no expense to the State, and to the satisfaction of the Engineer.

The Contractor shall provide documentation that all breakaway sign supports comply with FHWA NCHRP 350 or MASH crash-worthy requirements. The Contractor shall provide installation details at the preconstruction meeting for all breakaway sign support assemblies.

Sufficient traffic control devices have been included in these plans to sign one workspace. If the Contractor elects to work on additional sites simultaneously, the cost for additional traffic control devices shall be incidental to the contract unit price per unit for Traffic Control.

LANE CLOSURE RESTRICTION

Lane closures will not be allowed on any day from 6am to 9am and 4pm to 6pm at the following locations:

- I29 from 0.5 mile south of the Intersection with 271st St (Tea Interchange), north to 0.5 mile north of the Intersection with I90,
- I90 from 0.5 mile west of the Intersection with 471st St (Marion Road Interchange), east to 0.5 mile east of the Intersection with I229 and
- I229 in its entirety.

**0001-271, 0001-272, 0001-291 & 000P-292 - GUARDRAIL REPAIR
 BON HOMME, CHARLES MIX, CLAY, HUTCHINSON, LAKE, LINCOLN, MINER,
 MINNEHAHA, MOODY, TURNER, UNION & YANKTON COUNTIES**

ITEMIZED LIST FOR TRAFFIC CONTROL

| SIGN CODE | SIGN SIZE | DESCRIPTION | NUMBER REQUIRED | UNITS PER SIGN | UNITS |
|--------------------|------------------|---|------------------------|-----------------------|--------------|
| E5-1 | 36" x 32" | EXIT GORE SIGN | | 24 | |
| G20-2 | 36" x 18" | END ROAD WORK | 2 | 17 | 34 |
| R1-1 | 48" x 48" | STOP | | 34 | |
| R1-2 | 48" x 48" | YIELD | | 34 | |
| R2-1 | 30" x 36" | SPEED LIMIT __ | | 23 | |
| R2-1 | 36" x 48" | SPEED LIMIT __ | | 29 | |
| R2-1 | 48" x 60" | SPEED LIMIT __ | | 38 | |
| R2-6aP | 36" x 24" | FINES DOUBLE | | 20 | |
| R4-7 | 24" x 30" | KEEP RIGHT (SYMBOL) | | 18 | |
| R5-1 | 48" x 48" | DO NOT ENTER | | 34 | |
| R5-1a | 42" x 30" | WRONG WAY | | 25 | |
| R10-6 | 24" x 36" | STOP HERE ON RED | | 20 | |
| R11-2 | 48" x 30" | ROAD CLOSED | | 27 | |
| R11-3a | 60" x 30" | ROAD CLOSED __ MILES AHEAD LOCAL TRAFFIC ONLY | | 30 | |
| R11-4 | 60" x 30" | ROAD CLOSED TO THRU TRAFFIC | | 30 | |
| SW12-1b | 120" x 60" | HIGHWAY WORKERS GIVE'EM A BRAKE | | 80 | |
| W1-1 | 48" x 48" | LEFT OR RIGHT TURN ARROW | | 34 | |
| W1-2 | 48" x 48" | LEFT OR RIGHT CURVE ARROW | | 34 | |
| W1-3 | 48" x 48" | REVERSE TURN SIGN (LEFT OR RIGHT) | | 34 | |
| W1-4 | 48" x 48" | REVERSE CURVE SIGN (LEFT OR RIGHT) | | 34 | |
| W3-1 | 48" x 48" | STOP AHEAD (SYMBOL) | | 34 | |
| W3-2 | 48" x 48" | YIELD AHEAD (SYMBOL) | | 34 | |
| W3-3 | 48" x 48" | SIGNAL AHEAD (SYMBOL) | | 34 | |
| W3-4 | 48" x 48" | BE PREPARED TO STOP | | 34 | |
| W3-5 | 48" x 48" | SPEED REDUCTION (__ MPH) | | 34 | |
| W4-1 | 48" x 48" | MERGE (SYMBOL) | | 34 | |
| W4-2 | 48" x 48" | LEFT OR RIGHT LANE ENDS (SYMBOL) | 2 | 34 | 68 |
| W5-2 | 48" x 48" | NARROW BRIDGE | | 34 | |
| W5-3 | 48" x 48" | ONE LANE BRIDGE | | 34 | |
| W7-3a | 30" x 24" | NEXT __ MILES | | 18 | |
| W8-1 | 36" x 36" | BUMP | | 27 | |
| W8-6 | 48" x 48" | TRUCK CROSSING | | 34 | |
| W8-7 | 36" x 36" | LOOSE GRAVEL | | 27 | |
| W8-9a | 48" x 48" | SHOULDER DROP-OFF | | 34 | |
| W8-11 | 48" x 48" | UNEVEN LANES | | 34 | |
| W13-1 | 24" x 24" | ADVISORY SPEED PLATE | | 16 | |
| W16-2 | 30" x 24" | SUPPLEMENTAL DISTANCE PLAQUE | | 18 | |
| W20-1 | 48" x 48" | ROAD WORK AHEAD | 2 | 34 | 68 |
| W20-2 | 48" x 48" | DETOUR AHEAD | | 34 | |
| W20-3 | 48" x 48" | ROAD CLOSED AHEAD | | 34 | |
| W20-4 | 48" x 48" | ONE LANE ROAD AHEAD | 2 | 34 | 68 |
| W20-5 | 48" x 48" | LT. OR RT. LANE CLOSED AHEAD | 2 | 34 | 68 |
| W20-7a | 48" x 48" | FLAGGER | 2 | 34 | 68 |
| W21-1a | 48" x 48" | WORKERS (SYMBOL) | | 34 | |
| W21-2 | 36" x 36" | FRESH OIL | | 27 | |
| W21-3 | 48" x 48" | ROAD MACHINERY AHEAD | | 34 | |
| W21-5 | 48" x 48" | SHOULDER WORK | 2 | 34 | 68 |
| W21-5a | 48" x 48" | RIGHT SHOULDER CLOSED | | 34 | |
| W21-5b | 48" x 48" | RIGHT SHOULDER CLOSED AHEAD | | 34 | |
| **** | 12" x 36" | TYPE III OBJECT MARKER | | 15 | |
| **** | **** | TYPE III BARRICADE - 8 FT. SINGLE SIDED | | 40 | |
| **** | **** | TYPE III BARRICADE - 8 FT. DOUBLE SIDED | | 56 | |
| TOTAL UNITS | | | | | 442 |

**000I-271, 000I-272, 000I-291 & 000P-292 - GUARDRAIL REPAIR
 BON HOMME, CHARLES MIX, CLAY, HUTCHINSON, LAKE, LINCOLN, MINER,
 MINNEHAHA, MOODY, TURNER, UNION & YANKTON COUNTIES**

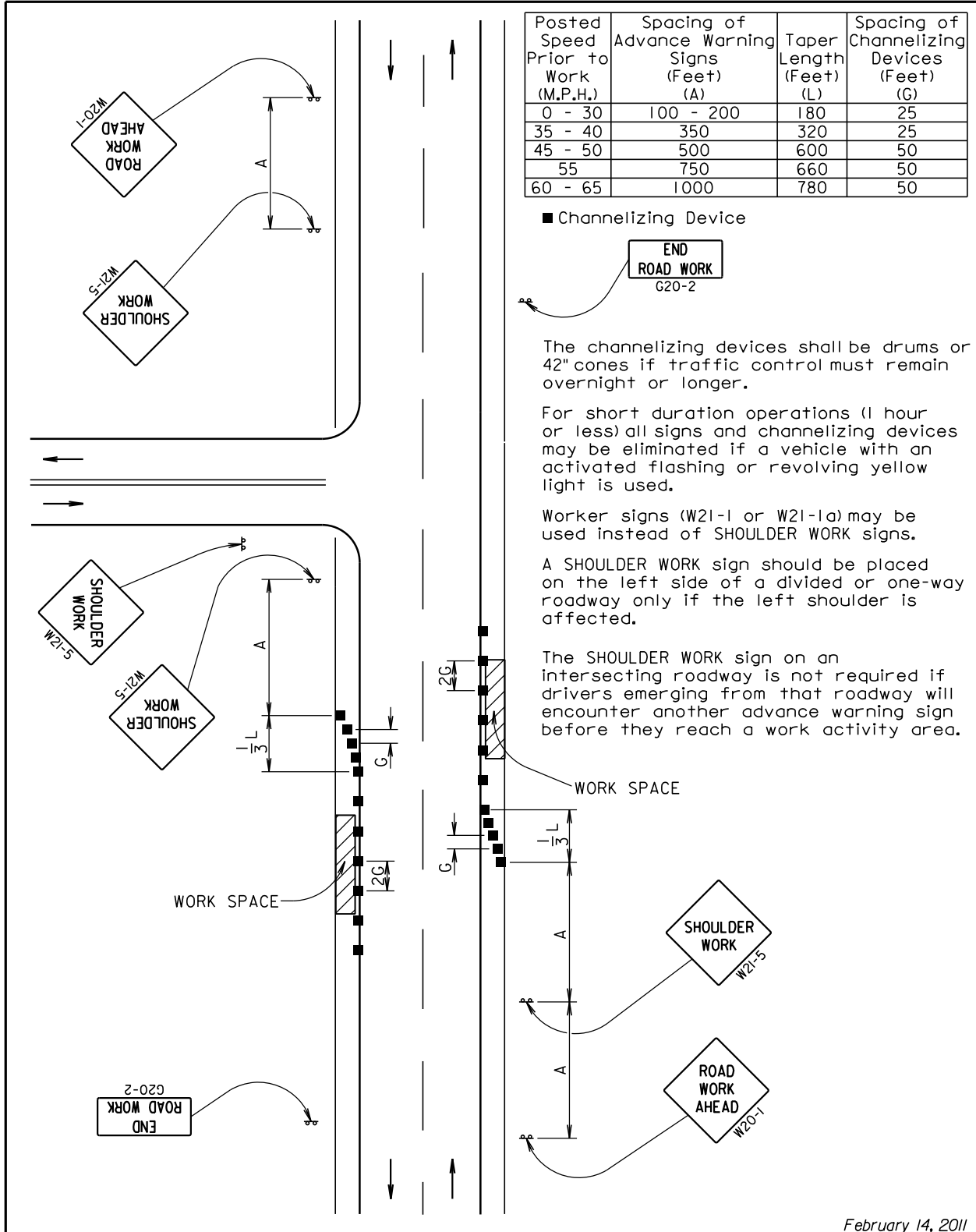

| Posted Speed Prior to Work (M.P.H.) | Spacing of Advance Warning Signs (Feet) (A) | Taper Length (Feet) (L) | Spacing of Channelizing Devices (Feet) (G) |
|-------------------------------------|---|-------------------------|--|
| 0 - 30 | 100 - 200 | 180 | 25 |
| 35 - 40 | 350 | 320 | 25 |
| 45 - 50 | 500 | 600 | 50 |
| 55 | 750 | 660 | 50 |
| 60 - 65 | 1000 | 780 | 50 |

■ Channelizing Device

**END
ROAD WORK
G20-2**

The channelizing devices shall be drums or 42" cones if traffic control must remain overnight or longer.

For short duration operations (1 hour or less) all signs and channelizing devices may be eliminated if a vehicle with an activated flashing or revolving yellow light is used.

Worker signs (W21-1 or W21-1a) may be used instead of SHOULDER WORK signs.

A SHOULDER WORK sign should be placed on the left side of a divided or one-way roadway only if the left shoulder is affected.

The SHOULDER WORK sign on an intersecting roadway is not required if drivers emerging from that roadway will encounter another advance warning sign before they reach a work activity area.

February 14, 2011

Published Date: 3rd Qtr. 2013

**S
D
D
O
T**



**GUIDES FOR TRAFFIC CONTROL DEVICES
 WORK ON SHOULDERS**

PLATE NUMBER
634.03

Sheet 1 of 1

**0001-271, 0001-272, 0001-291 & 000P-292 - GUARDRAIL REPAIR
 BON HOMME, CHARLES MIX, CLAY, HUTCHINSON, LAKE, LINCOLN, MINER,
 MINNEHAHA, MOODY, TURNER, UNION & YANKTON COUNTIES**

| Posted Speed Prior to Work (M.P.H.) | Spacing of Advance Warning Signs (Feet) (A) | Spacing of Channelizing Devices (Feet) (G) |
|-------------------------------------|---|--|
| 0 - 30 | 200 | 25 |
| 35 - 40 | 350 | 25 |
| 45 - 50 | 500 | 50 |
| 55 | 750 | 50 |
| 60 - 65 | 1000 | 50 |

-  Flagger
-  Channelizing Device

For low-volume traffic situations with short work zones on straight roadways where the flagger is visible to road users approaching from both directions, a single flagger may be used.

The ROAD WORK AHEAD and the END ROAD WORK signs may be omitted for short duration operations (1 hour or less).

For tack and/or flush seal operations, when flaggers are not being used, the FRESH OIL sign (W21-2) shall be displayed in advance of the liquid asphalt areas.

Flashing warning lights and/or flags may be used to call attention to the advance warning signs.

The channelizing devices shall be drums or 42" cones.

Channelizing devices are not required along the centerline adjacent to work area when pilot cars are utilized for escorting traffic through the work area.

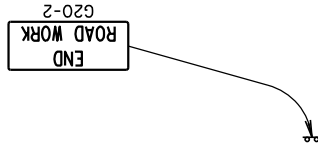

Channelizing devices and flaggers shall be used at intersecting roads to control intersecting road traffic as required.

The buffer space should be extended so that the two-way traffic taper is placed before a horizontal or vertical curve to provide adequate sight distance for the flagger and queue of stopped vehicles.

Warning sign sequence in opposite direction same as below.

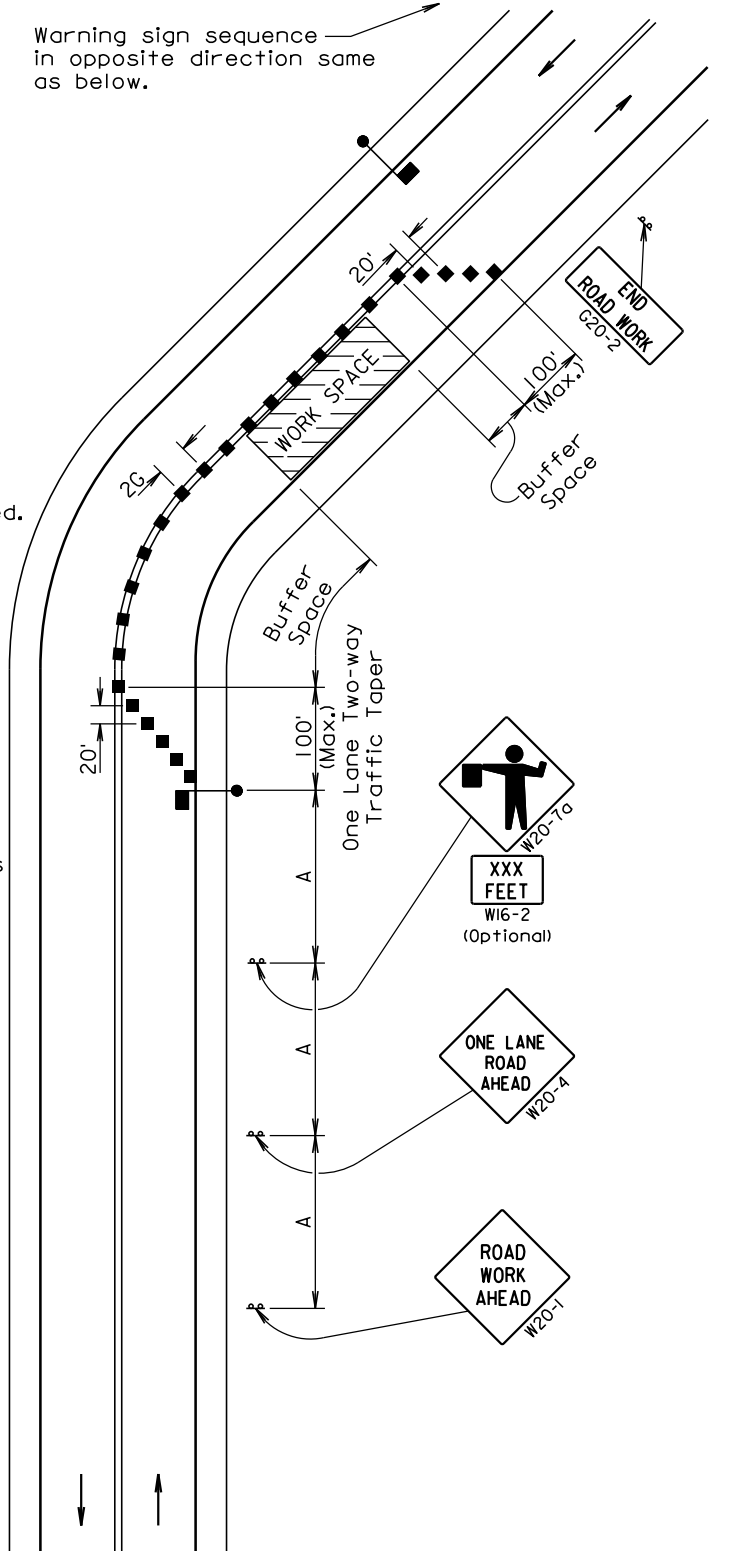

February 14, 2011

Published Date: 3rd Qtr. 2013

**S
D
D
O
T**

**GUIDES FOR TRAFFIC CONTROL DEVICES
 LANE CLOSURE WITH FLAGGER PROVIDED**

PLATE NUMBER
 634.23

Sheet 1 of 1

**0001-271, 0001-272, 0001-291 & 000P-292 - GUARDRAIL REPAIR
 BON HOMME, CHARLES MIX, CLAY, HUTCHINSON, LAKE, LINCOLN, MINER,
 MINNEHAHA, MOODY, TURNER, UNION & YANKTON COUNTIES**

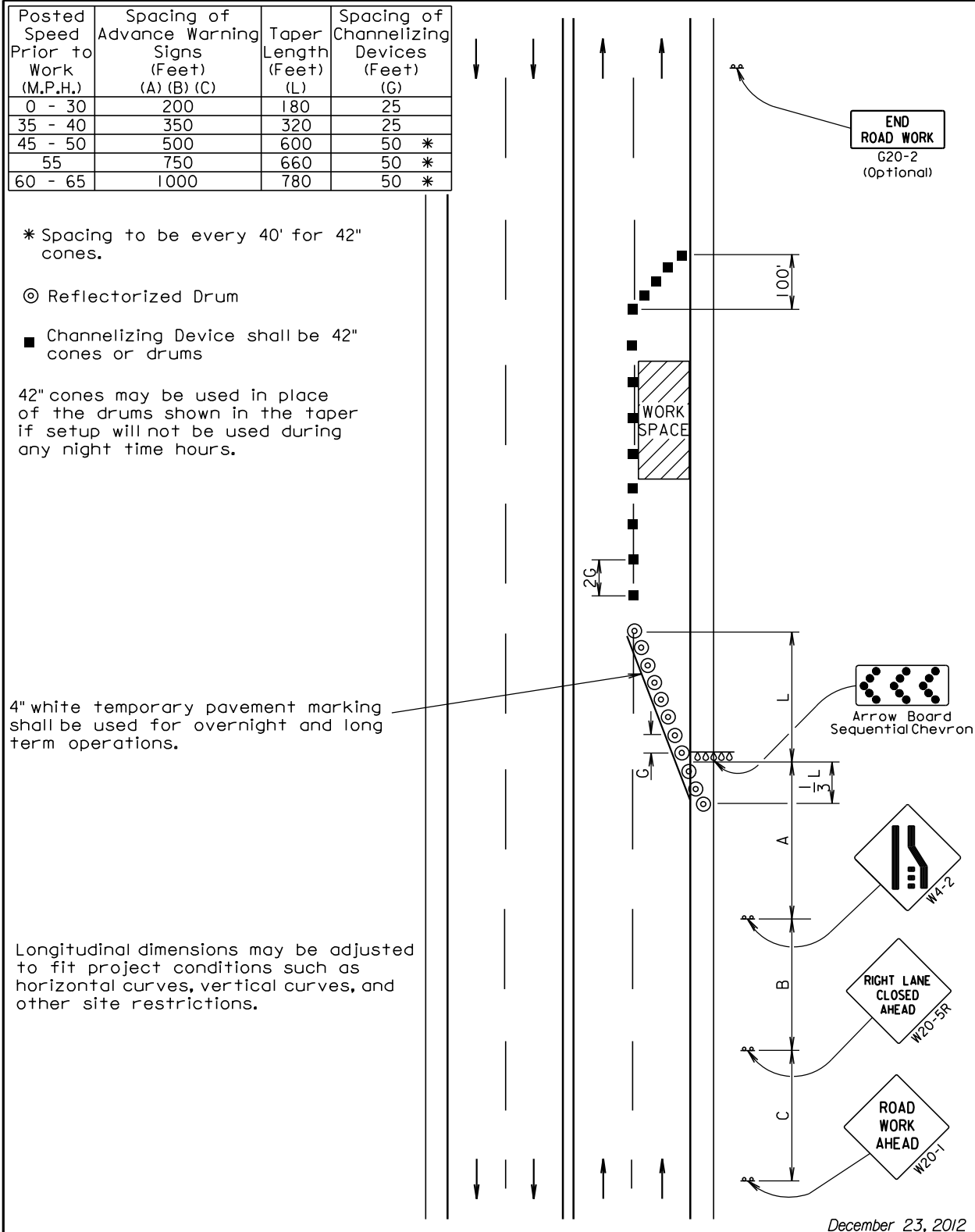

December 23, 2012

Published Date: 3rd Qtr. 2013

**S
D
D
O
T**

**GUIDES FOR TRAFFIC CONTROL DEVICES
 4-LANE UNDIVIDED, RIGHT LANE CLOSED**

PLATE NUMBER
634.47

Sheet 1 of 1

**0001-271, 0001-272, 0001-291 & 000P-292 - GUARDRAIL REPAIR
 BON HOMME, CHARLES MIX, CLAY, HUTCHINSON, LAKE, LINCOLN, MINER,
 MINNEHAHA, MOODY, TURNER, UNION & YANKTON COUNTIES**

- ⊙ Reflectorized Drum
- Channelizing Device shall be 42" cones or drums
- Movable Concrete Barrier

42" cones may be used in place of the drums shown in the taper if setup will not be used during any night time hours.

**For distances 1/2 mile or greater.

The barrier in this diagram shows one method that may be used to close a shoulder of a long term project. The use of a barrier should be based on the need determined by the Highway Authority.

The movable concrete barrier layout is shown elsewhere in the plans.

| Posted Speed Prior to Work (M.P.H.) | Spacing of Advance Warning Signs (Feet) | | | Taper Length (Feet) (L) | Spacing of Channelizing Devices (Feet) (G) |
|-------------------------------------|---|------|-----|-------------------------|--|
| | (A) | (B) | (C) | | |
| 0 - 30 | 200 | | | 180 | 25 |
| 35 - 40 | 350 | | | 320 | 25 |
| 45 - 50 | 500 | | | 600 | 50 * |
| 55 | 750 | | | 660 | 50 * |
| 60 - 65 | 1000 | | | 780 | 50 * |
| | (A) | (B) | | | |
| 70 - 75 | 1000 | 1600 | | 1125 | 50 * |

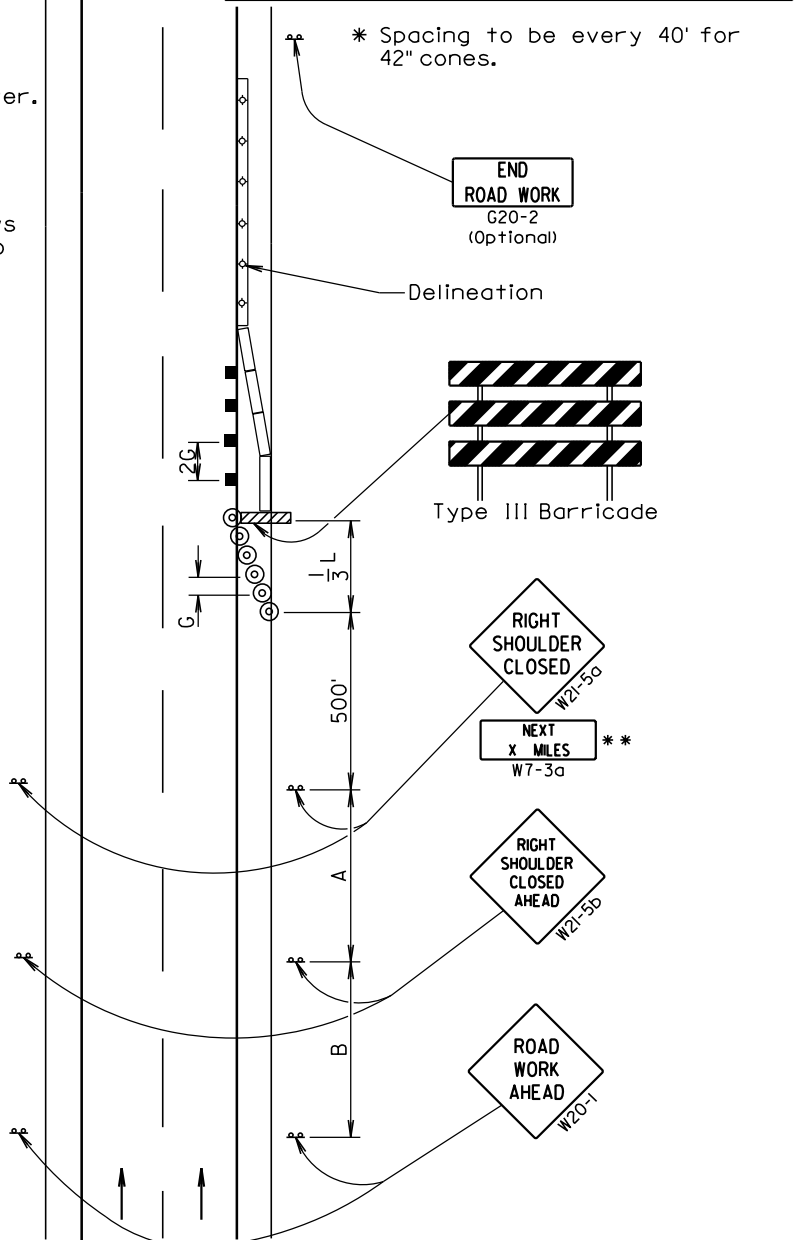

December 23, 2012

Published Date: 3rd Qtr. 2013

**S
D
D
O
T**

**GUIDES FOR TRAFFIC CONTROL DEVICES
 SHOULDER CLOSED**

PLATE NUMBER
 634.61

Sheet 1 of 1

**0001-271, 0001-272, 0001-291 & 000P-292 - GUARDRAIL REPAIR
 BON HOMME, CHARLES MIX, CLAY, HUTCHINSON, LAKE, LINCOLN, MINER,
 MINNEHAHA, MOODY, TURNER, UNION & YANKTON COUNTIES**

** Shall be used for overnight and long term operations.

WITHOUT BARRIER

| Posted Speed Prior to Work (M.P.H.) | Spacing of Advance Warning Signs (Feet) | | | Taper Length (Feet) (L) |
|-------------------------------------|---|------|------|-------------------------|
| | (A) | (B) | (C) | |
| 0 - 30 | 200 | | | 180 |
| 35 - 40 | | 350 | | 320 |
| 45 - 50 | | 500 | | 600 |
| 55 | | 750 | | 660 |
| 60 - 65 | | 1000 | | 780 |
| | (A) | (B) | (C) | |
| 70 - 75 | 1000 | 1600 | 2600 | 900 |

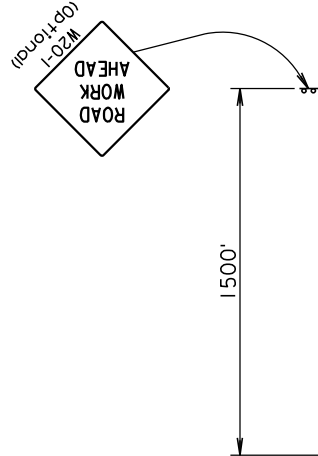

| Posted Speed Prior to Work (M.P.H.) | Length of Longitudinal Buffer Space (Feet) |
|-------------------------------------|--|
| 20 | 35 |
| 25 | 55 |
| 30 | 85 |
| 35 | 120 |
| 40 | 170 |
| 45 | 220 |
| 50 | 280 |
| 55 | 335 |
| 60 | 415 |
| 65 | 485 |
| 70 | 535 |
| 75 | 585 |

This procedure also applies when work is being performed in the lane adjacent to the median on a divided highway. Under these conditions, LEFT LANE CLOSED signs and the corresponding LANE REDUCTION symbol signs shall be used.

- ⊙ Reflectorized Drum
- Channelizing Device shall be 42" cones or drums

42" cones may be used in place of the drums shown in the taper if setup will not be used during any night time hours.

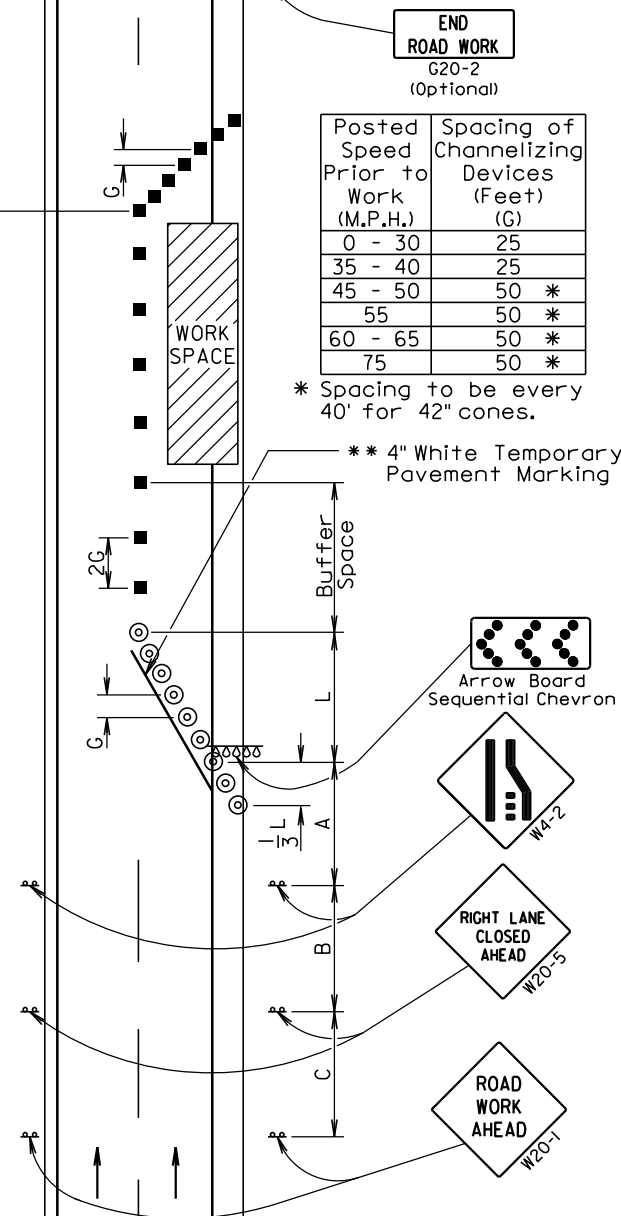
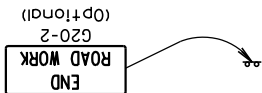

| Posted Speed Prior to Work (M.P.H.) | Spacing of Channelizing Devices (Feet) (G) |
|-------------------------------------|--|
| 0 - 30 | 25 |
| 35 - 40 | 25 |
| 45 - 50 | 50 * |
| 55 | 50 * |
| 60 - 65 | 50 * |
| 75 | 50 * |

* Spacing to be every 40' for 42" cones.

** 4" White Temporary Pavement Marking

December 23, 2012

Published Date: 3rd Qtr. 2013

**S
D
D
O
T**

GUIDES FOR TRAFFIC CONTROL DEVICES LANE CLOSURE WITHOUT BARRIER

PLATE NUMBER
 634.64

Sheet 1 of 1

**0001-271, 0001-272, 0001-291 & 000P-292 - GUARDRAIL REPAIR
 BON HOMME, CHARLES MIX, CLAY, HUTCHINSON, LAKE, LINCOLN, MINER,
 MINNEHAHA, MOODY, TURNER, UNION & YANKTON COUNTIES**

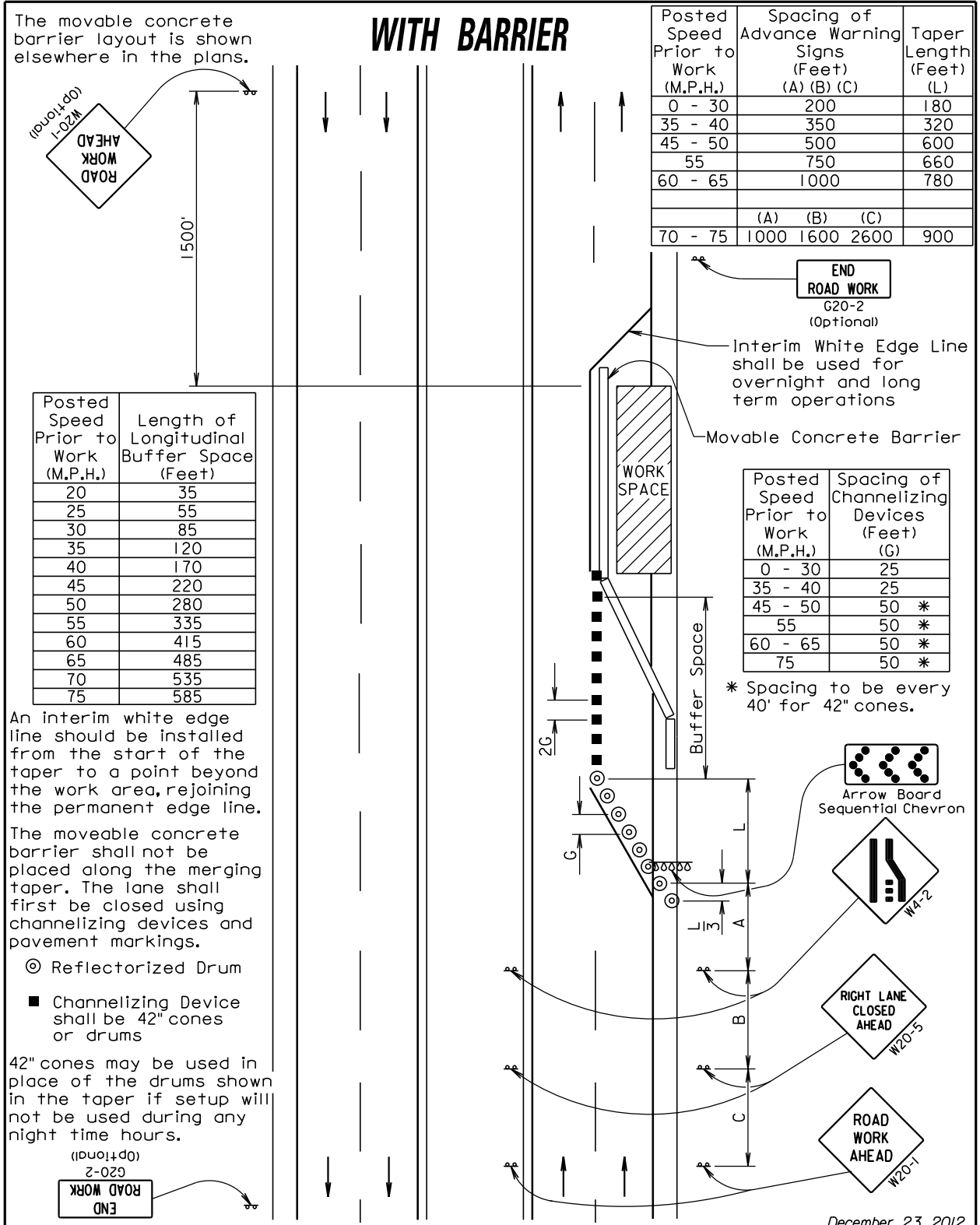

An interim white edge line should be installed from the start of the taper to a point beyond the work area, rejoining the permanent edge line.

The moveable concrete barrier shall not be placed along the merging taper. The lane shall first be closed using channelizing devices and pavement markings.

⊙ Reflectorized Drum

■ Channelizing Device shall be 42" cones or drums

42" cones may be used in place of the drums shown in the taper if setup will not be used during any night time hours.

G20-2 (Optional)
 END ROAD WORK

December 23, 2012

**0001-271, 0001-272, 0001-291 & 000P-292 - GUARDRAIL REPAIR
 BON HOMME, CHARLES MIX, CLAY, HUTCHINSON, LAKE, LINCOLN, MINER,
 MINNEHAHA, MOODY, TURNER, UNION & YANKTON COUNTIES**

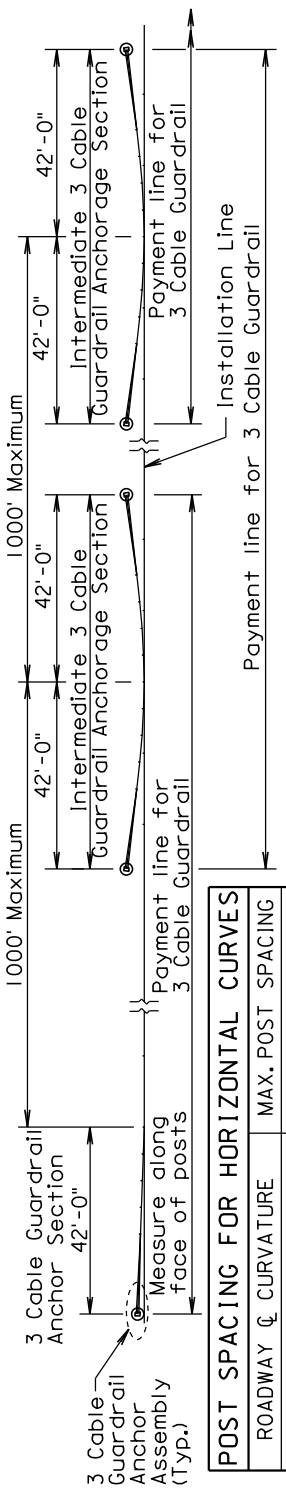

PLAN

| POST SPACING FOR HORIZONTAL CURVES | |
|------------------------------------|-------------------|
| ROADWAY CURVATURE | MAX. POST SPACING |
| 8° and Less | 16' |
| Greater than 8° to 13° | 12' |
| Greater than 13° | NOT ALLOWED |

GENERAL NOTES:
 Either flanged channel steel posts or S3x5.7 steel I beam posts shall be used, but post type shall be consistent throughout the project. The S3x5.7 Steel I Beam post shall be used for the end posts when the flanged channel steel post is used as line posts. All costs associated with furnishing and constructing the 3 cable guardrail anchor assembly including the concrete anchor, cable anchor bracket, compensating device, steel turnbuckle cable assembly, and necessary hardware shall be incidental to the contract unit price per Each for "3 Cable Guardrail Anchor Assembly". All costs associated with furnishing and constructing the 3 cable guardrail including posts, cable, cable splices, and hardware shall be incidental to the contract unit price per Ft for "3 Cable Guardrail".

The following table and criteria shall apply to the arrangement of the Spring Cable End Assemblies (Compensation Devices) and Turnbuckle Cable End Assemblies:

| LENGTH OF CABLE RUN | CRITERIA FOR ARRANGEMENT OF THE SPRING CABLE END ASSEMBLIES (COMPENSATION DEVICES) AND TURNBUCKLE CABLE END ASSEMBLIES |
|----------------------------|--|
| To 500' | Use turnbuckle on the approaching traffic end and compensating device on the other end of each individual cable, except in the W Beam to 3 Cable Transition where all compensating devices shall be provided at the bridge ends. |
| Greater than 500' to 1000' | Use compensating device on each end of each individual cable. |
| Greater than 1000' | Start new run by interlacing at last parallel post as shown above. |

All Compensating Devices shall be attached to the cable anchor bracket when one end of the run is attached to a bridge. Compensating Devices must have a spring rate of 450 ± 50 Lbs. per inch and shall have a total available travel of 6" minimum.

The cable shall be retensioned after the initial 2 week pretension period in accordance with the following table:

| | | | | | | | | | | | | | | |
|--------------------------|------------|------------|----------|----------|----------|----------|----------|----------|----------|----------|----------|--------|-----------|------------|
| Temperature Range (Deg.) | 120 to 110 | 109 to 100 | 99 to 90 | 89 to 80 | 79 to 70 | 69 to 60 | 59 to 50 | 49 to 40 | 39 to 30 | 29 to 20 | 19 to 10 | 9 to 0 | -1 to -10 | -11 to -20 |
| Spring Compression (In.) | 1 | 1 1/4 | 1 1/2 | 1 3/4 | 2 | 2 1/4 | 2 1/2 | 2 3/4 | 3 | 3 1/4 | 3 1/2 | 3 3/4 | 4 | 4 1/4 |

December 23, 2010

Published Date: 3rd Qtr. 2013

DOT

3 CABLE GUARDRAIL

PLATE NUMBER
629.01

Sheet 1 of 6

**0001-271, 0001-272, 0001-291 & 000P-292 - GUARDRAIL REPAIR
 BON HOMME, CHARLES MIX, CLAY, HUTCHINSON, LAKE, LINCOLN, MINER,
 MINNEHAHA, MOODY, TURNER, UNION & YANKTON COUNTIES**

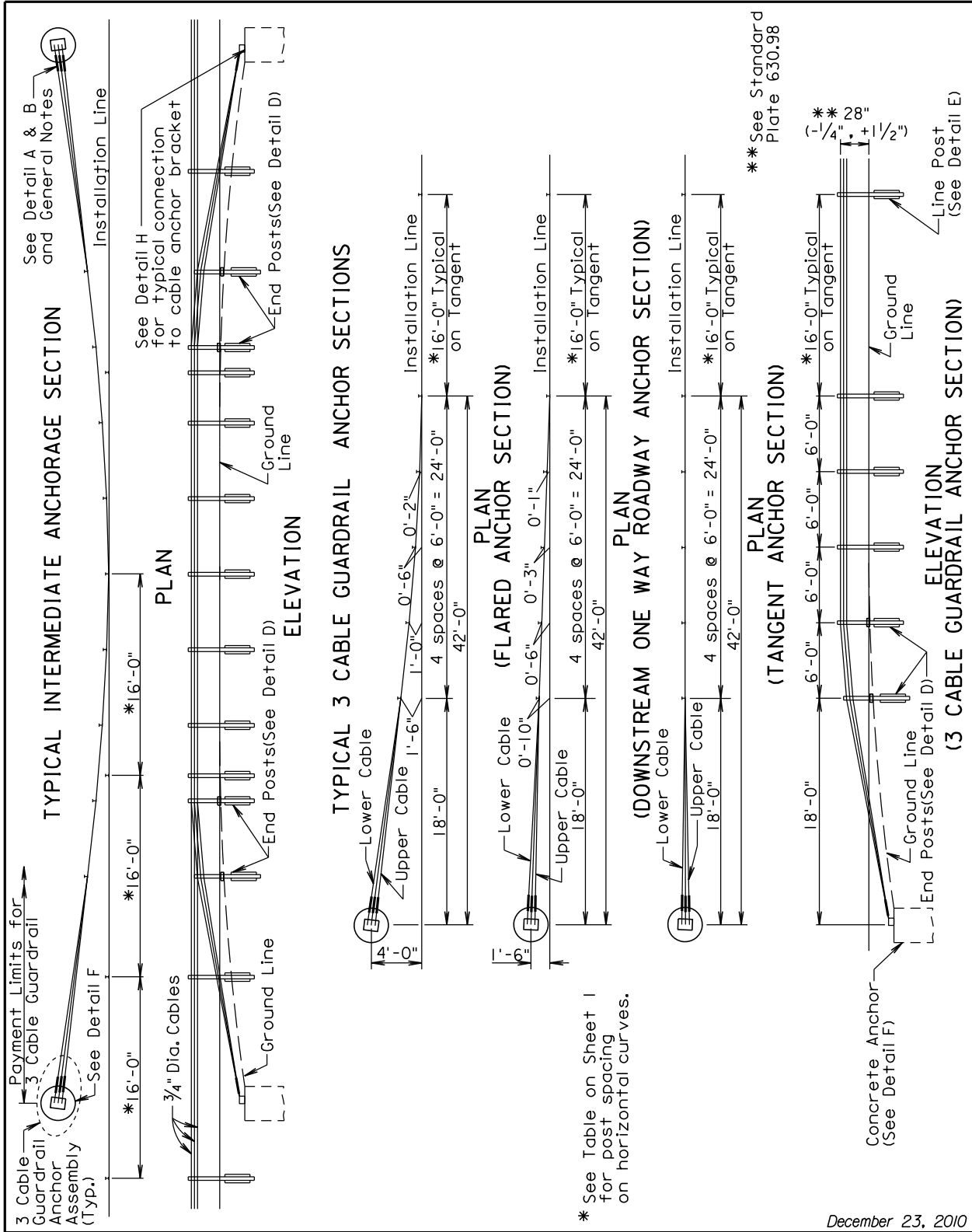

| | | | |
|-------------------------------|--------------|--------------------------|--|
| Published Date: 3rd Qtr. 2013 | TODDS | 3 CABLE GUARDRAIL | December 23, 2010 PLATE NUMBER 629.01 |
| | | | |

**0001-271, 0001-272, 0001-291 & 000P-292 - GUARDRAIL REPAIR
 BON HOMME, CHARLES MIX, CLAY, HUTCHINSON, LAKE, LINCOLN, MINER,
 MINNEHAHA, MOODY, TURNER, UNION & YANKTON COUNTIES**

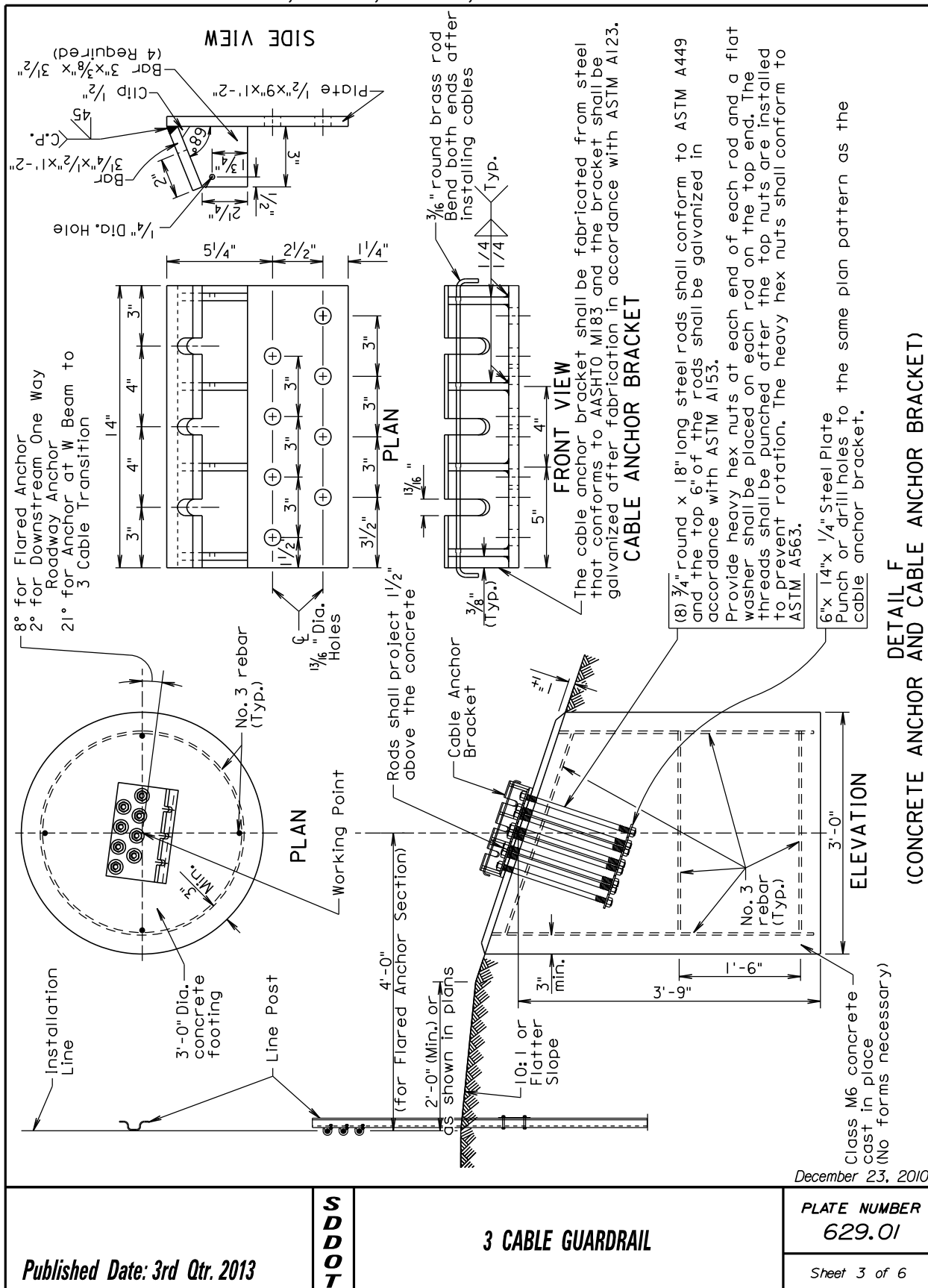

Published Date: 3rd Qtr. 2013

DOT

3 CABLE GUARDRAIL

| | |
|--------------|--------|
| PLATE NUMBER | 629.01 |
| Sheet 3 of 6 | |

0001-271, 0001-272, 0001-291 & 000P-292 - GUARDRAIL REPAIR
 BON HOMME, CHARLES MIX, CLAY, HUTCHINSON, LAKE, LINCOLN, MINER,
 MINNEHAHA, MOODY, TURNER, UNION & YANKTON COUNTIES

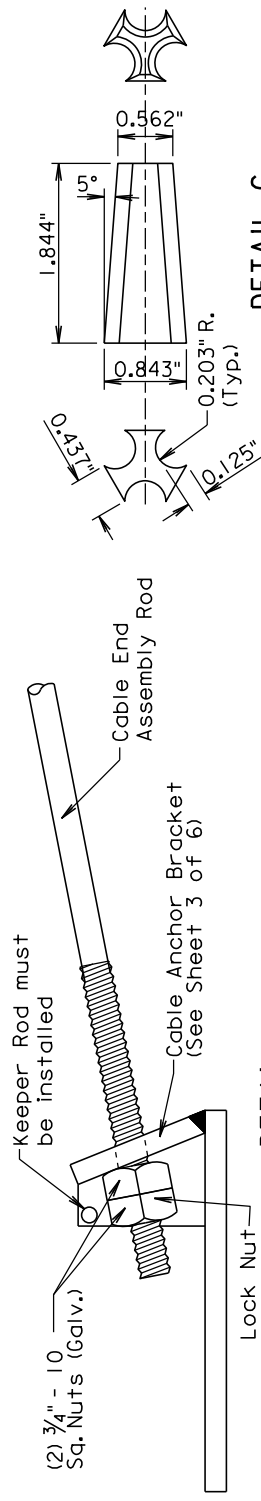

DETAIL H
 (CABLE END ASSEMBLY ROD
 CONNECTION TO CABLE ANCHOR BRACKET)

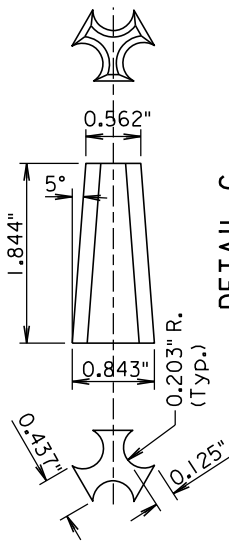

DETAIL G
 (TYPICAL WEDGE FOR ALL
 SPLICES AND CABLE
 FITTINGS)

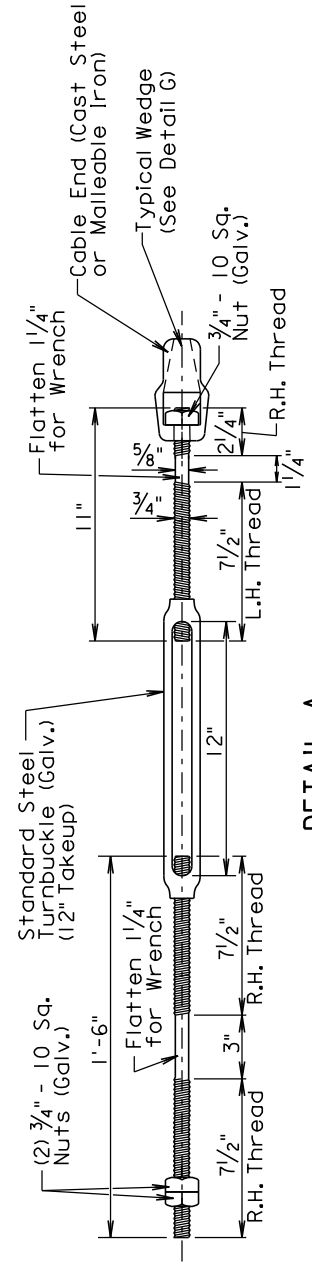

DETAIL A
 (STEEL TURNBUCKLE CABLE END ASSEMBLY)
 Minimum Tensile Strength = 25,000 Lbs.

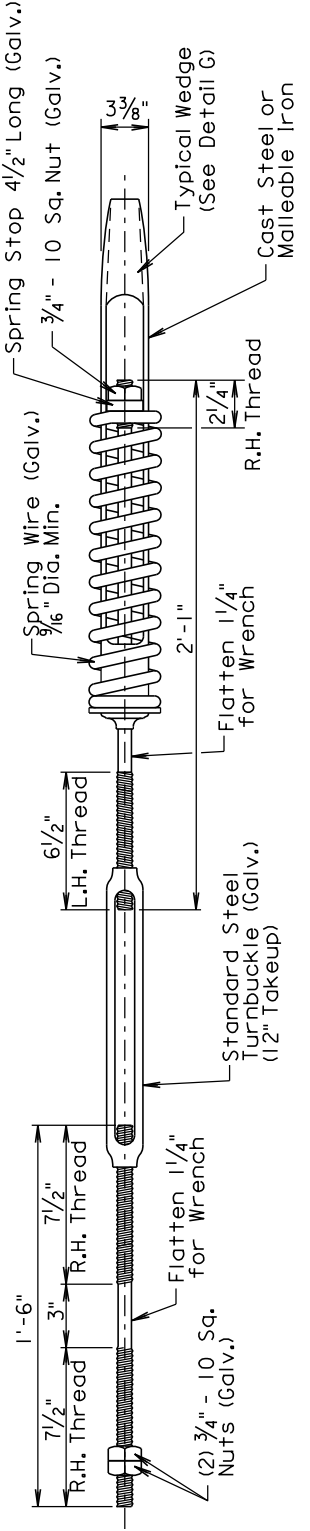

DETAIL B
 (SPRING CABLE END ASSEMBLY WITH TURNBUCKLE)
 (COMPENSATING DEVICE)

December 23, 2010

Published Date: 3rd Qtr. 2013

TODD'S

3 CABLE GUARDRAIL

PLATE NUMBER
 629.01

Sheet 4 of 6

0001-271, 0001-272, 0001-291 & 000P-292 - GUARDRAIL REPAIR
 BON HOMME, CHARLES MIX, CLAY, HUTCHINSON, LAKE, LINCOLN, MINER,
 MINNEHAHA, MOODY, TURNER, UNION & YANKTON COUNTIES

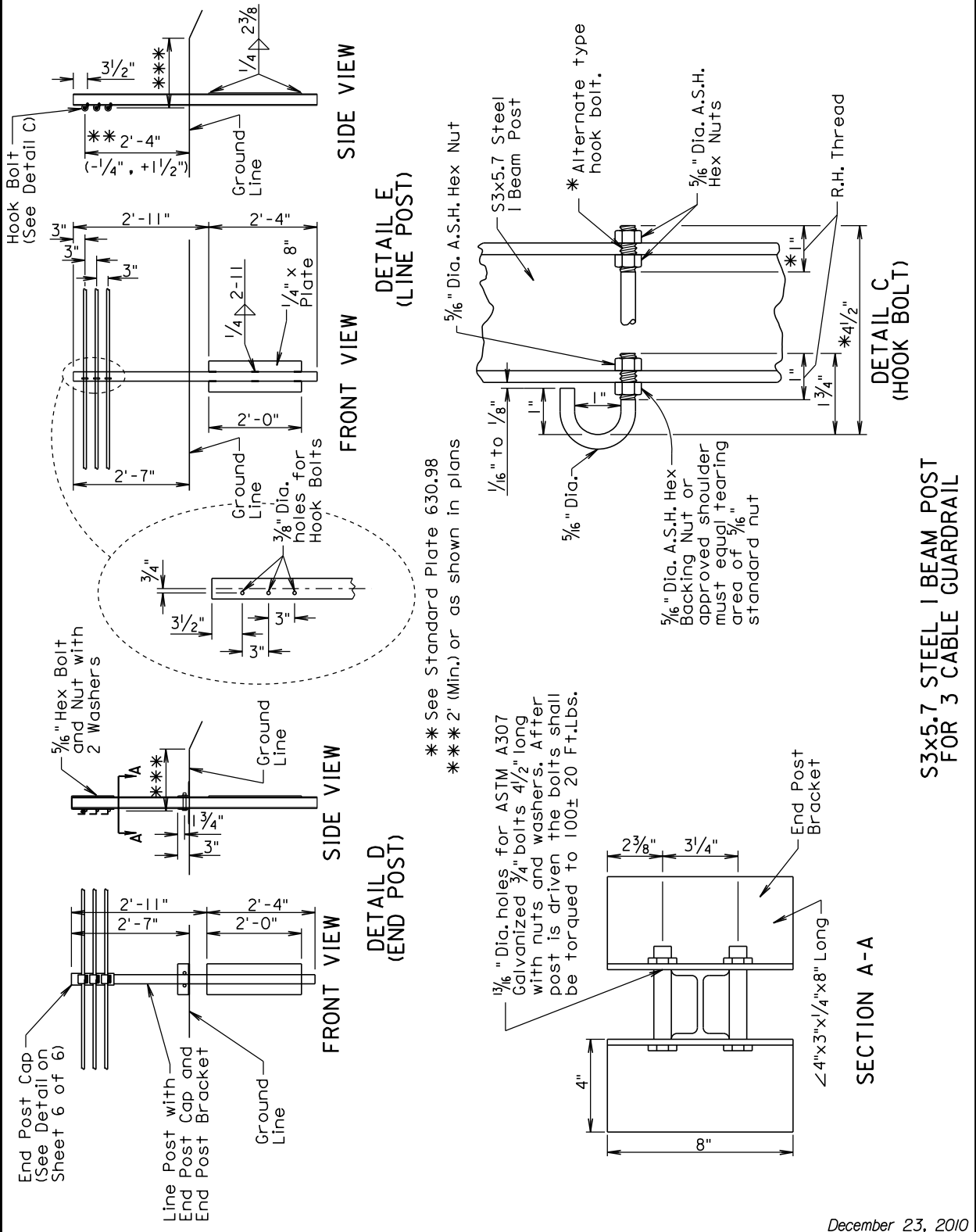

S3x5.7 STEEL I BEAM POST
 FOR 3 CABLE GUARDRAIL

December 23, 2010

| | | | |
|-------------------------------|--------------|--------------------------|------------------------|
| Published Date: 3rd Qtr. 2013 | TODDS | 3 CABLE GUARDRAIL | PLATE NUMBER 629.01 |
| | | | Sheet 5 of 6 |

**0001-271, 0001-272, 0001-291 & 000P-292 - GUARDRAIL REPAIR
 BON HOMME, CHARLES MIX, CLAY, HUTCHINSON, LAKE, LINCOLN, MINER,
 MINNEHAHA, MOODY, TURNER, UNION & YANKTON COUNTIES**

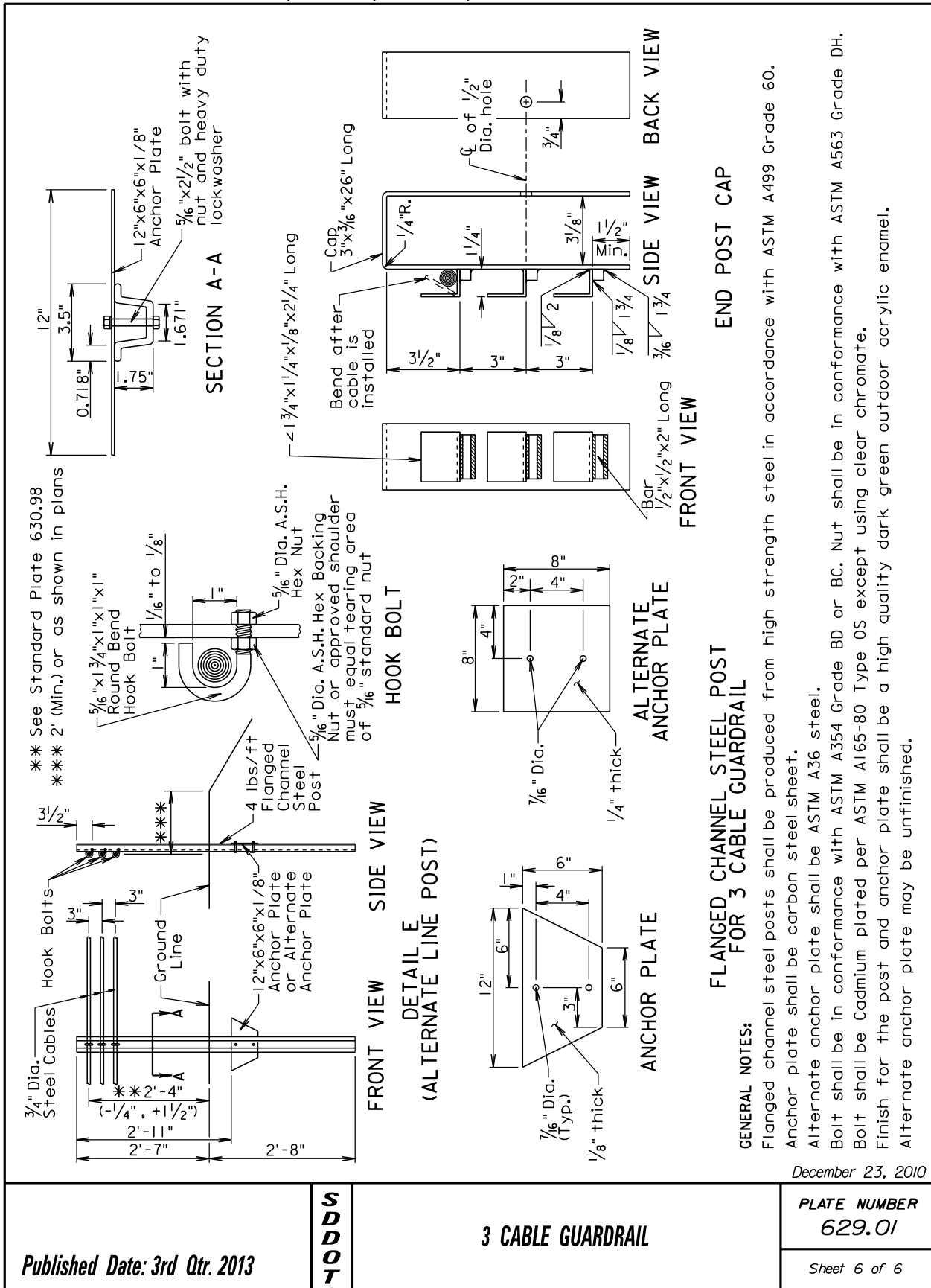

Published Date: 3rd Qtr. 2013

TODDS

3 CABLE GUARDRAIL

December 23, 2010

PLATE NUMBER
 629.01

Sheet 6 of 6

**0001-271, 0001-272, 0001-291 & 000P-292 - GUARDRAIL REPAIR
 BON HOMME, CHARLES MIX, CLAY, HUTCHINSON, LAKE, LINCOLN, MINER,
 MINNEHAHA, MOODY, TURNER, UNION & YANKTON COUNTIES**

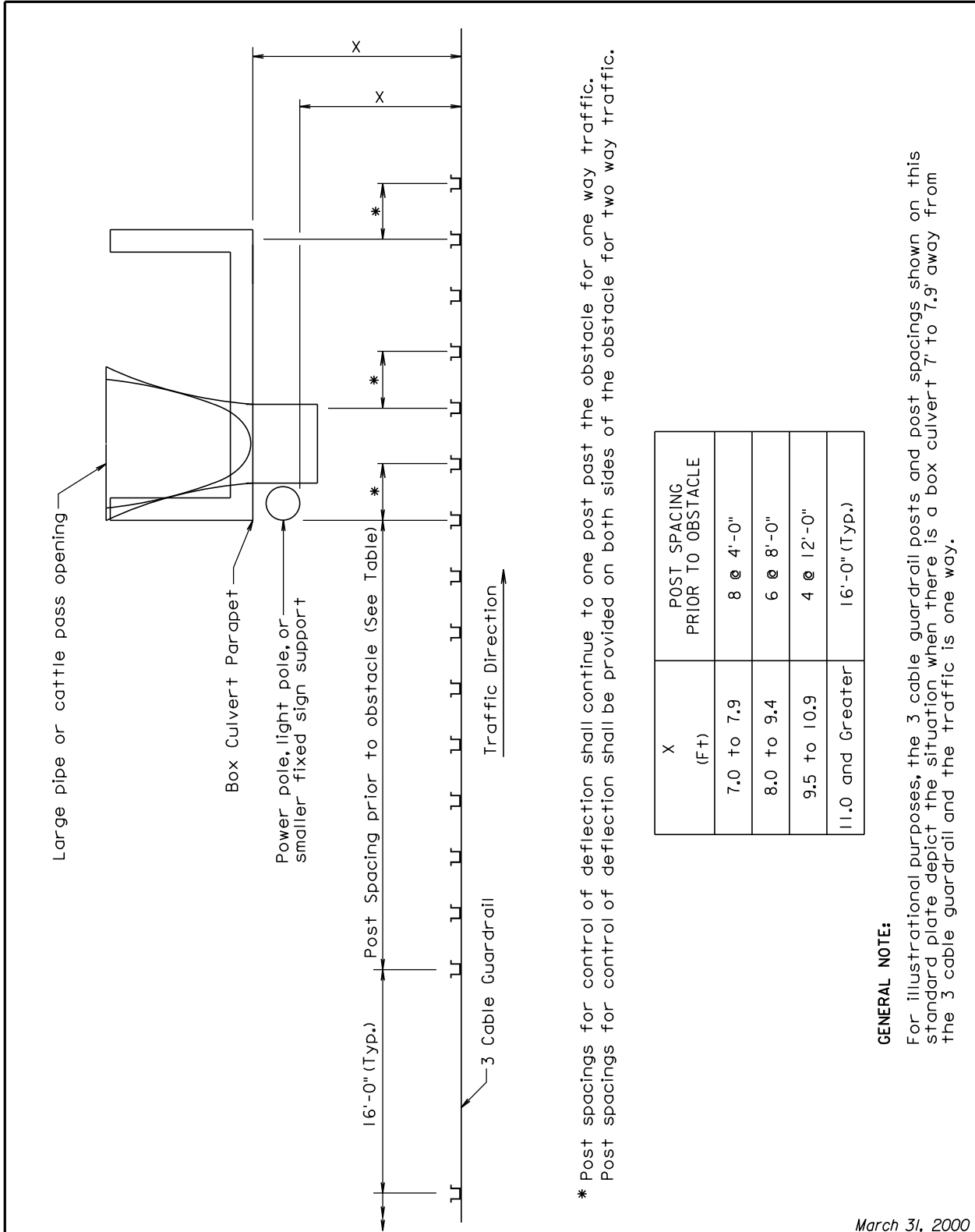

* Post spacings for control of deflection shall continue to one post past the obstacle for one way traffic.
 Post spacings for control of deflection shall be provided on both sides of the obstacle for two way traffic.

| X (Ft) | POST SPACING PRIOR TO OBSTACLE |
|------------------|--------------------------------|
| 7.0 to 7.9 | 8 @ 4'-0" |
| 8.0 to 9.4 | 6 @ 8'-0" |
| 9.5 to 10.9 | 4 @ 12'-0" |
| 11.0 and Greater | 16'-0" (Typ.) |

GENERAL NOTE:

For illustrational purposes, the 3 cable guardrail posts and post spacings shown on this standard plate depict the situation when there is a box culvert 7 to 7.9' away from the 3 cable guardrail and the traffic is one way.

March 31, 2000

| | | | |
|-------------------------------|----------------------------------|---|-------------------------------|
| Published Date: 3rd Qtr. 2013 | S D D O T | 3 CABLE GUARDRAIL POST SPACING FOR DEFLECTION CONTROL | PLATE NUMBER 629.02 |
| | | | Sheet 1 of 1 |

**0001-271, 0001-272, 0001-291 & 000P-292 - GUARDRAIL REPAIR
 BON HOMME, CHARLES MIX, CLAY, HUTCHINSON, LAKE, LINCOLN, MINER,
 MINNEHAHA, MOODY, TURNER, UNION & YANKTON COUNTIES**

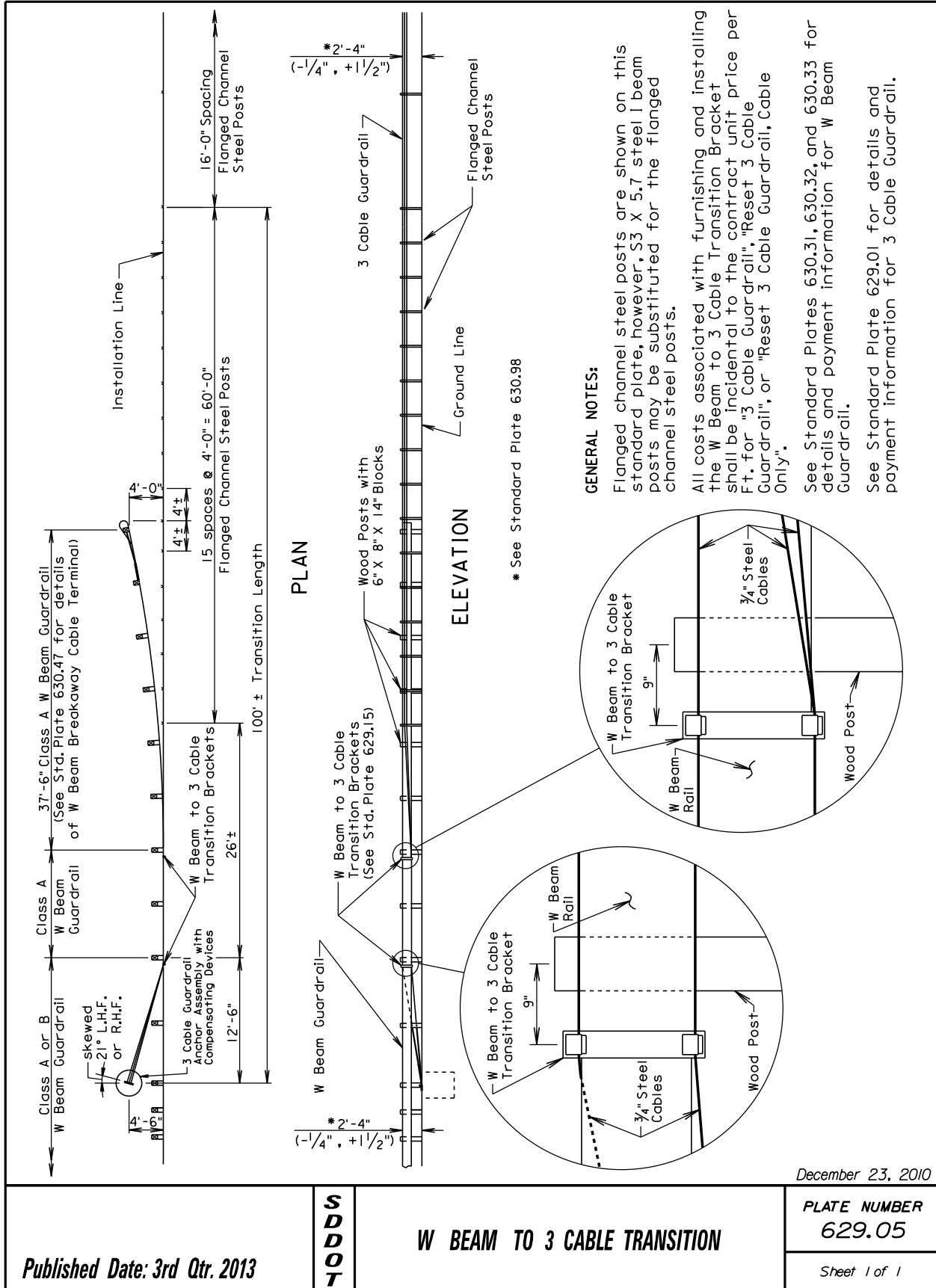

GENERAL NOTES:

Flanged channel steel posts are shown on this standard plate, however, S3 X 5.7 steel I beam posts may be substituted for the flanged channel steel posts.

All costs associated with furnishing and installing the W Beam to 3 Cable Transition Bracket shall be incidental to the contract unit price per Ft. for "3 Cable Guardrail", "Reset 3 Cable Guardrail", or "Reset 3 Cable Guardrail, Cable Only".

See Standard Plates 630.31, 630.32, and 630.33 for details and payment information for W Beam Guardrail.

See Standard Plate 629.01 for details and payment information for 3 Cable Guardrail.

* See Standard Plate 630.98

December 23, 2010

Published Date: 3rd Qtr. 2013

SDOT

W BEAM TO 3 CABLE TRANSITION

PLATE NUMBER
629.05

Sheet 1 of 1

**0001-271, 0001-272, 0001-291 & 000P-292 - GUARDRAIL REPAIR
 BON HOMME, CHARLES MIX, CLAY, HUTCHINSON, LAKE, LINCOLN, MINER,
 MINNEHAHA, MOODY, TURNER, UNION & YANKTON COUNTIES**

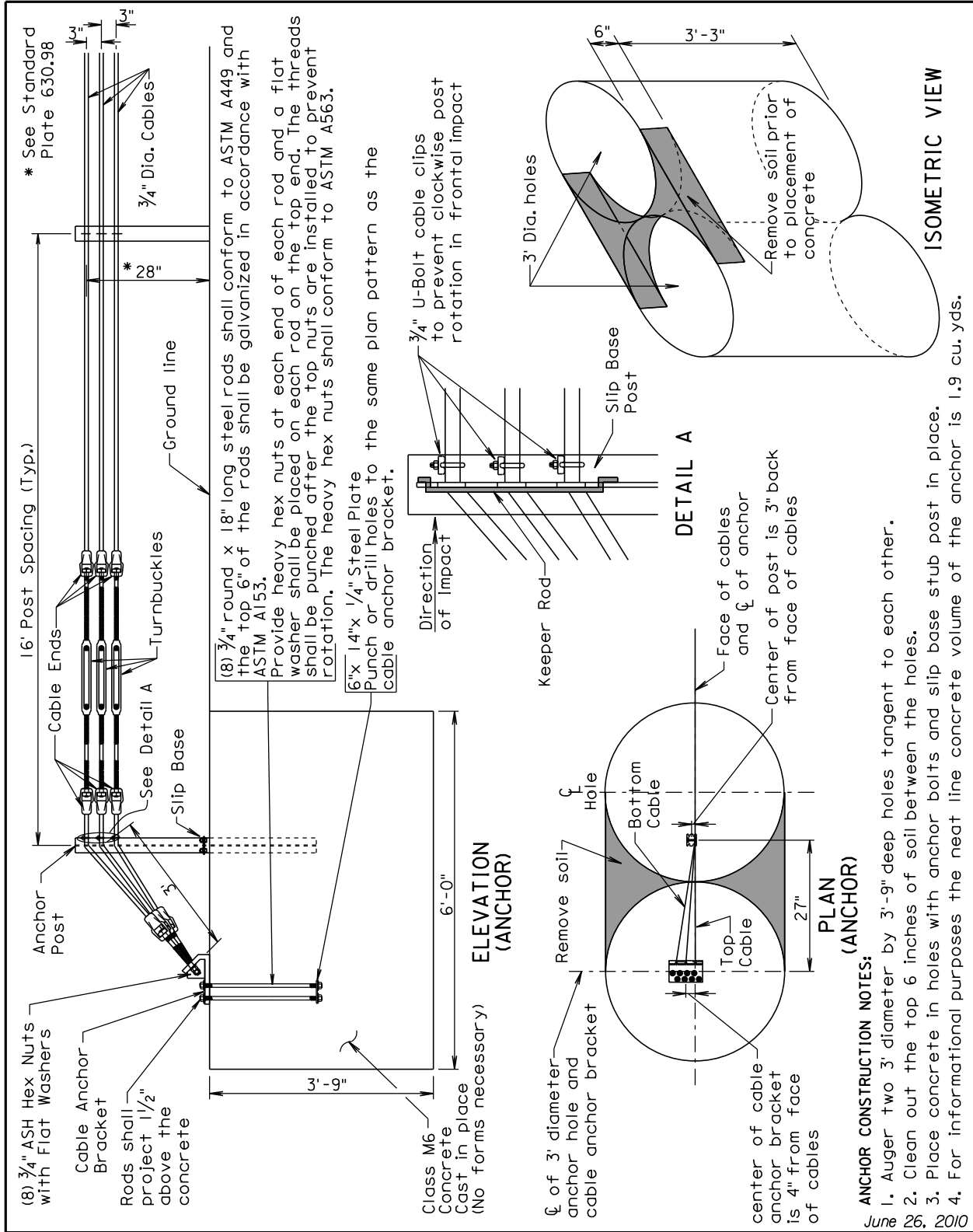

Published Date: 3rd Qtr. 2013

DOT

**3 CABLE GUARDRAIL SLIP BASE
 ANCHOR ASSEMBLY**

PLATE NUMBER
 629.10

Sheet 1 of 3

**0001-271, 0001-272, 0001-291 & 000P-292 - GUARDRAIL REPAIR
 BON HOMME, CHARLES MIX, CLAY, HUTCHINSON, LAKE, LINCOLN, MINER,
 MINNEHAHA, MOODY, TURNER, UNION & YANKTON COUNTIES**

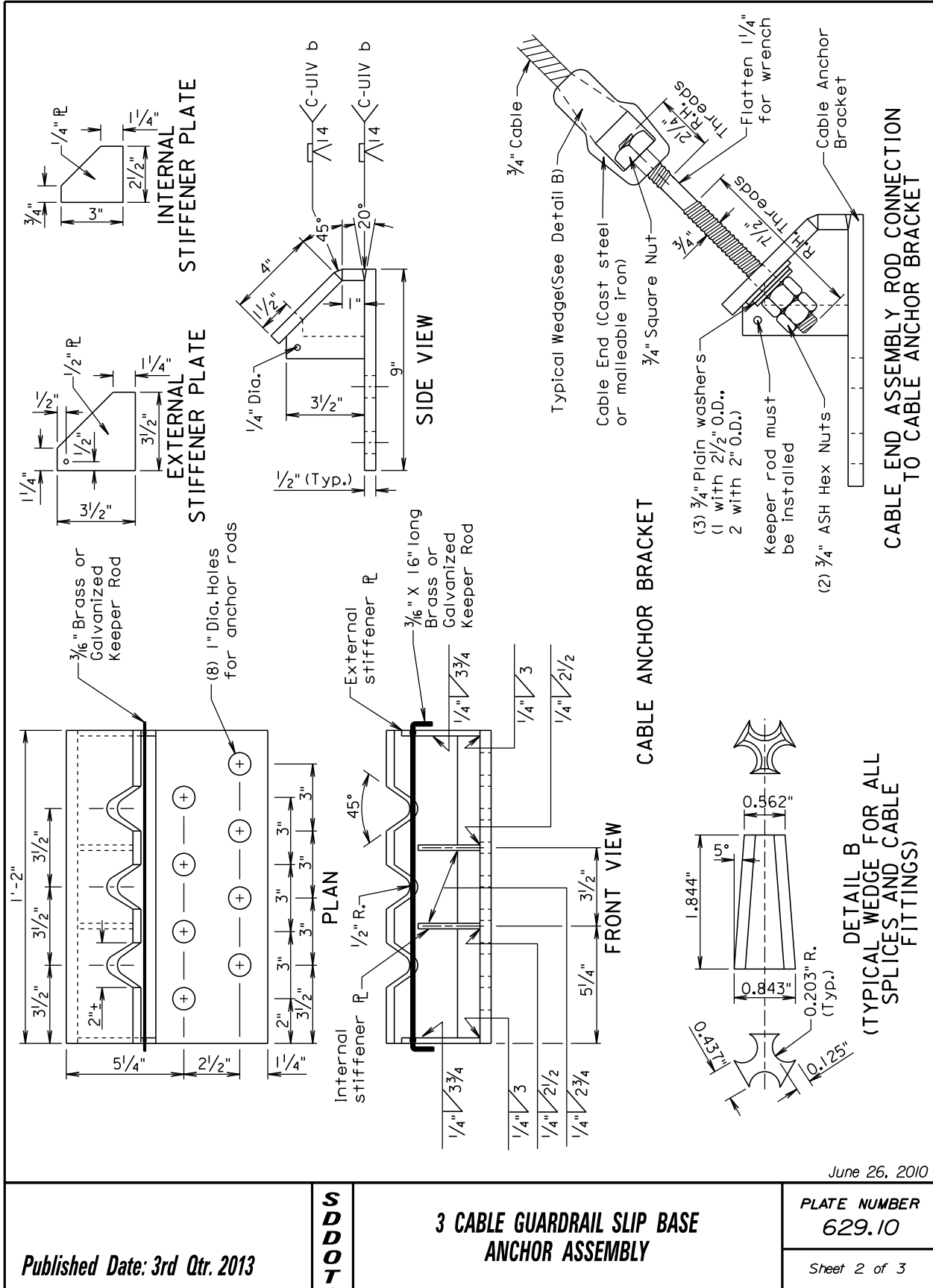

June 26, 2010

Published Date: 3rd Qtr. 2013

DOT

**3 CABLE GUARDRAIL SLIP BASE
 ANCHOR ASSEMBLY**

PLATE NUMBER
 629.10

Sheet 2 of 3

**0001-271, 0001-272, 0001-291 & 000P-292 - GUARDRAIL REPAIR
 BON HOMME, CHARLES MIX, CLAY, HUTCHINSON, LAKE, LINCOLN, MINER,
 MINNEHAHA, MOODY, TURNER, UNION & YANKTON COUNTIES**

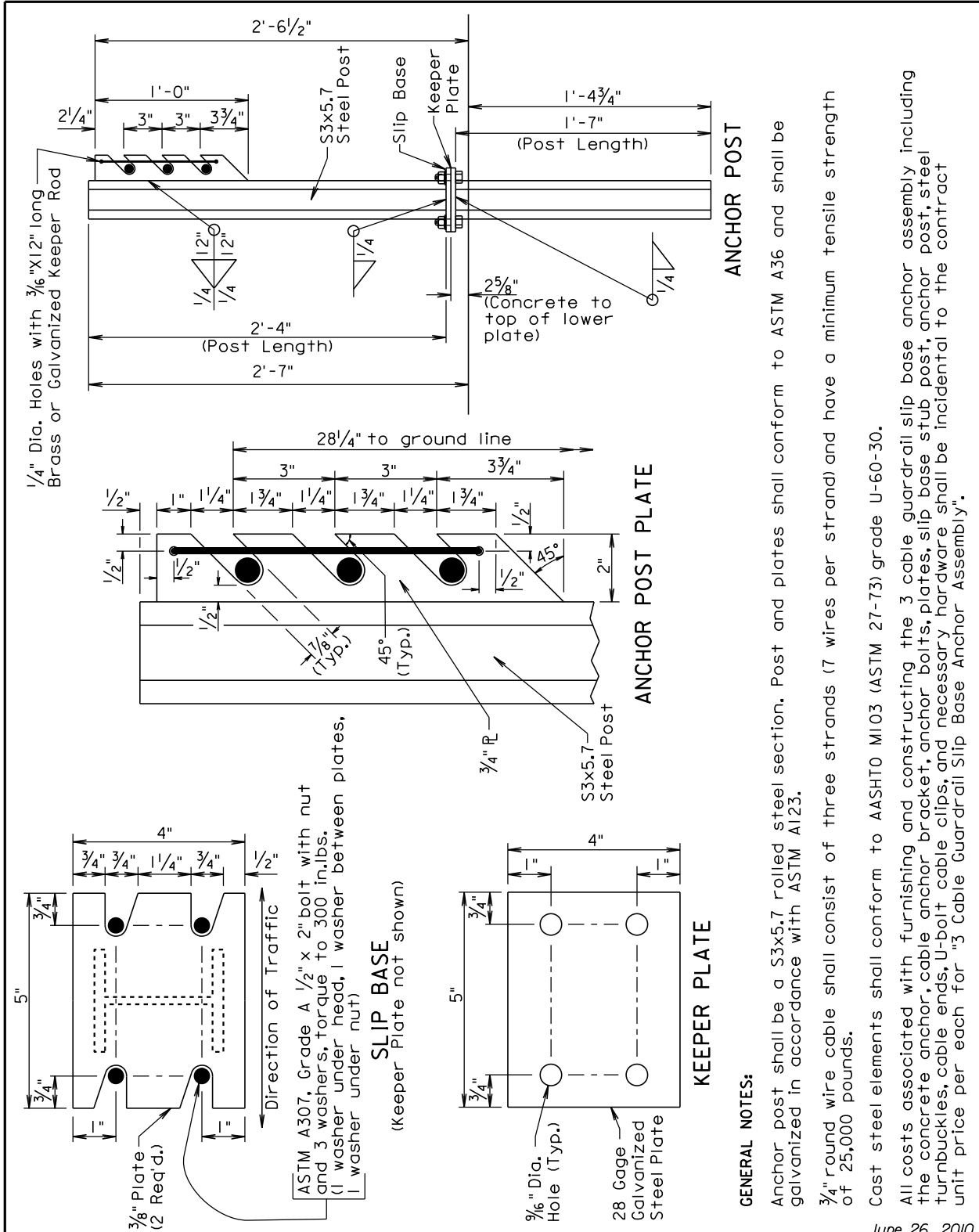

GENERAL NOTES:

- Anchor post shall be a S3x5.7 rolled steel section. Post and plates shall conform to ASTM A36 and shall be galvanized in accordance with ASTM A123.
- 3/4" round wire cable shall consist of three strands (7 wires per strand) and have a minimum tensile strength of 25,000 pounds.
- Cast steel elements shall conform to AASHTO M103 (ASTM 27-73) grade U-60-30.
- All costs associated with furnishing and constructing the 3 cable guardrail slip base anchor assembly including the concrete anchor, cable anchor bracket, anchor bolts, plates, slip base stub post, anchor post, steel turnbuckles, cable ends, U-bolt cable clips, and necessary hardware shall be incidental to the contract unit price per each for "3 Cable Guardrail Slip Base Anchor Assembly".

June 26, 2010

| | | | |
|--------------------------------------|-------------------|--|--|
| <p>Published Date: 3rd Qtr. 2013</p> | <p>DOT</p> | <p>3 CABLE GUARDRAIL SLIP BASE ANCHOR ASSEMBLY</p> | <p>PLATE NUMBER 629.10</p> |
| | | | <p>Sheet 3 of 3</p> |

**0001-271, 0001-272, 0001-291 & 000P-292 - GUARDRAIL REPAIR
 BON HOMME, CHARLES MIX, CLAY, HUTCHINSON, LAKE, LINCOLN, MINER,
 MINNEHAHA, MOODY, TURNER, UNION & YANKTON COUNTIES**

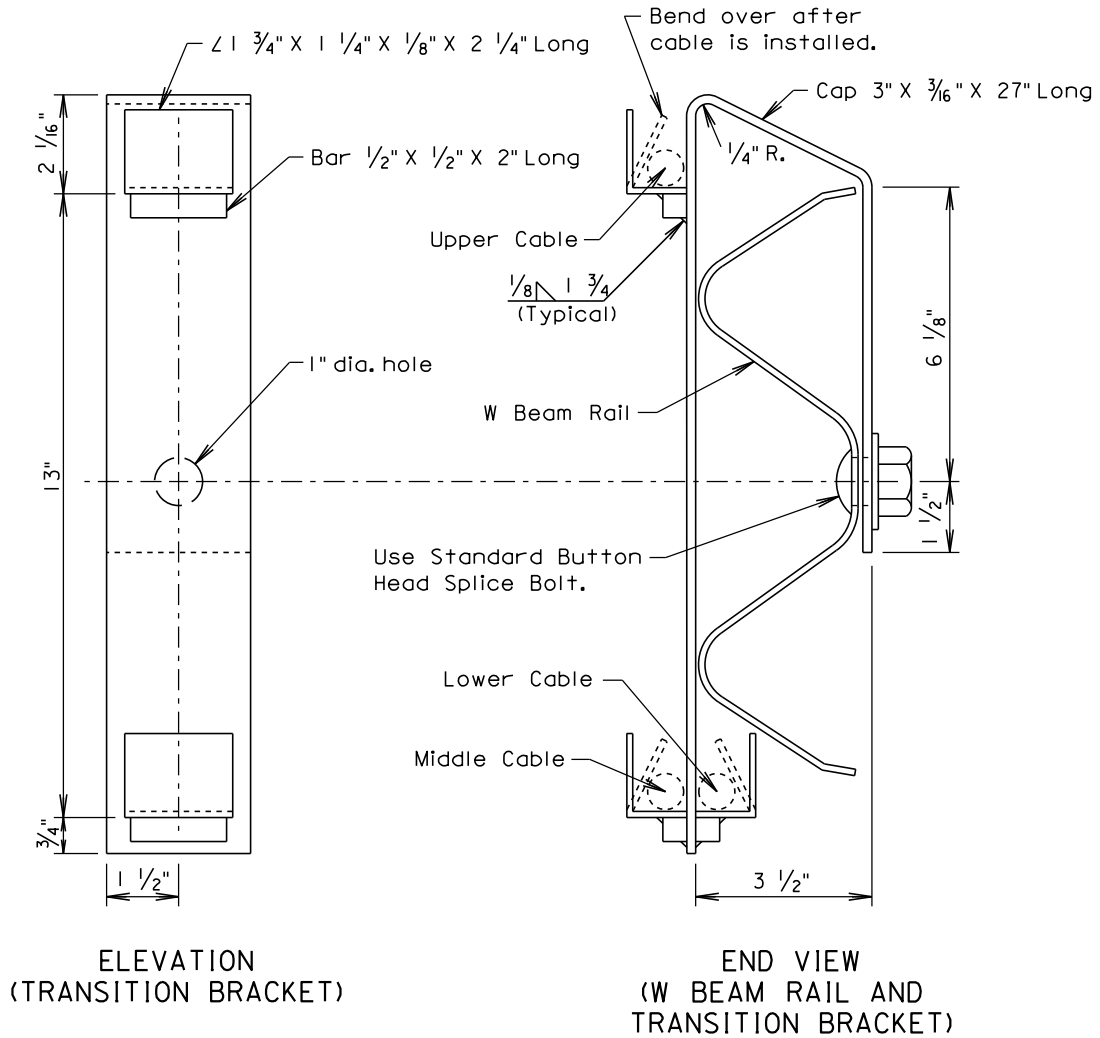

GENERAL NOTES:

Steel used in the fabrication of the bracket shall conform to ASTM A36 and the bracket shall be galvanized after fabrication in accordance with ASTM A123.

March 31, 2000

Published Date: 3rd Qtr. 2013

**S
D
D
O
T**

W BEAM TO 3 CABLE TRANSITION BRACKET

**PLATE NUMBER
629.15**

Sheet 1 of 1

**0001-271, 0001-272, 0001-291 & 000P-292 - GUARDRAIL REPAIR
 BON HOMME, CHARLES MIX, CLAY, HUTCHINSON, LAKE, LINCOLN, MINER,
 MINNEHAHA, MOODY, TURNER, UNION & YANKTON COUNTIES**

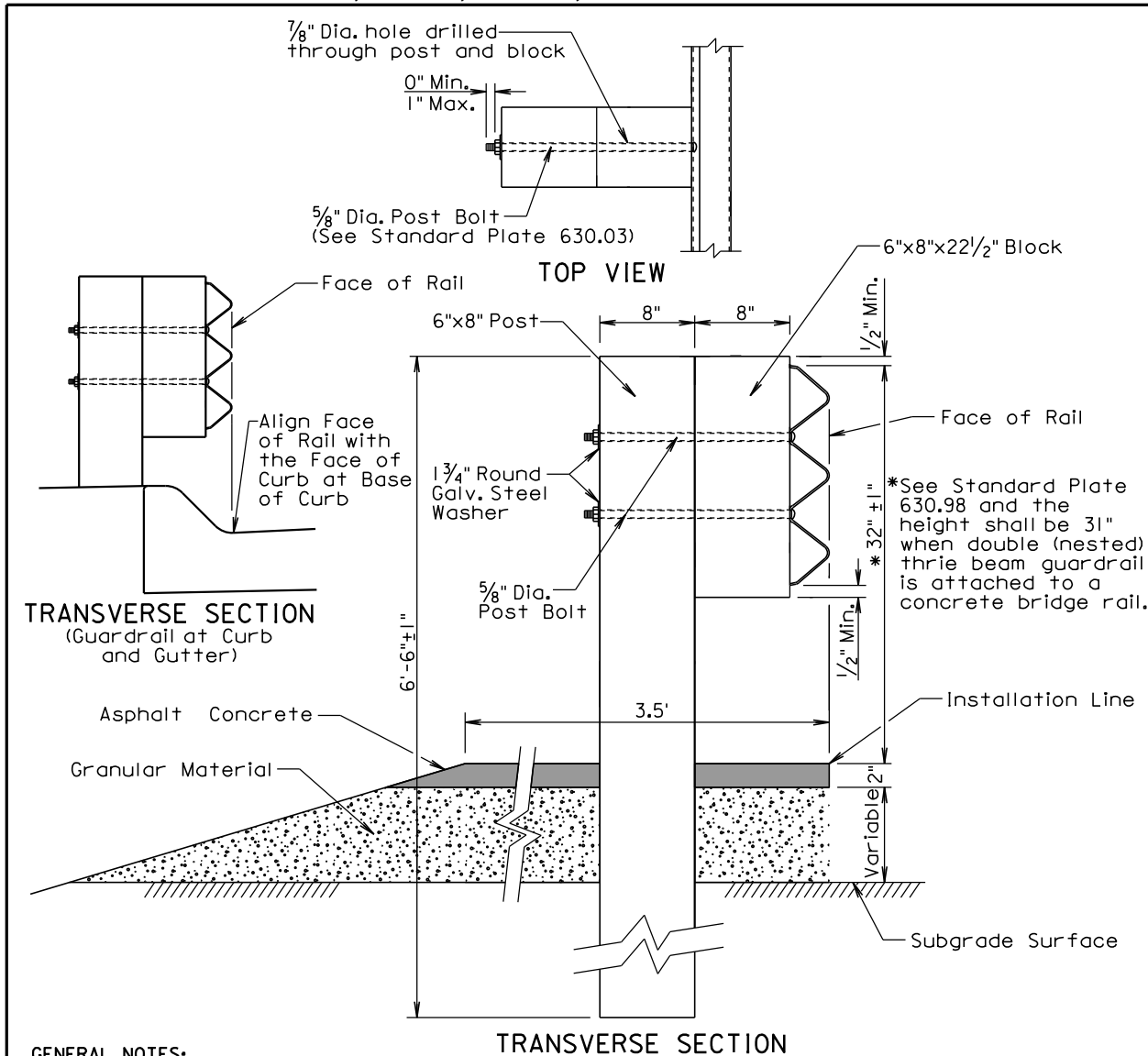

GENERAL NOTES:

Asphalt concrete shall be the same type used elsewhere on the project or shall be as specified in the plans. If asphalt concrete is not specified in the plans, the asphalt concrete shall conform to the SD Standard Specifications for "Asphalt Concrete Composite." For informational purposes, the Rate of Materials for the 3.5' wide section of asphalt concrete as shown above shall be 4.80 Tons per Station.

Granular material shall be the same type used elsewhere on the project or shall be as specified in the plans. If granular material type is not specified in the plans, the material shall conform to the SD Standard Specifications for "Base Course". The granular material shall be placed the same thickness as the mainline surfacing or as specified in the plans.

Surfacing and embankment quantities will be paid for separately and will NOT be incidental to the "Thrie Beam Guardrail" bid item.

The cross slope for the surfacing and subgrade surface shall be as specified in the plans (See Typical Sections and/or Cross Sections).

The top of posts and top of block shall have a true square cut. The top of post and top of block shall be flush.

December 23, 2010

| | | |
|-------------------|---|-------------------------------|
| SD DOT | THRIE BEAM GUARDRAIL POST INSTALLATION | PLATE NUMBER 630.01 |
| | | Sheet 1 of 1 |

Published Date: 3rd Qtr. 2013

**0001-271, 0001-272, 0001-291 & 000P-292 - GUARDRAIL REPAIR
 BON HOMME, CHARLES MIX, CLAY, HUTCHINSON, LAKE, LINCOLN, MINER,
 MINNEHAHA, MOODY, TURNER, UNION & YANKTON COUNTIES**

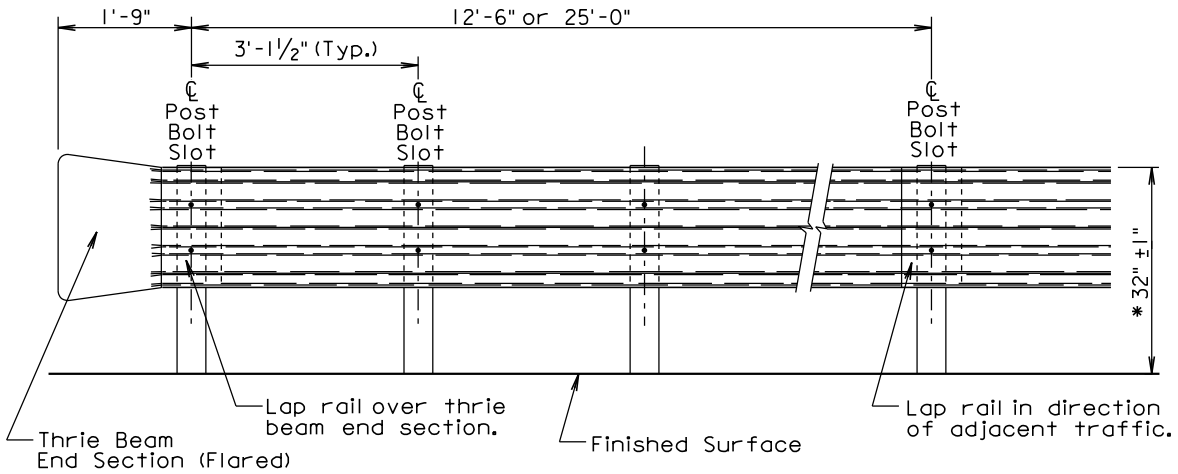

ELEVATION

* See Standard Plate 630.98 and the height shall be 31" when double (nested) thrie beam guardrail is attached to a concrete bridge rail.

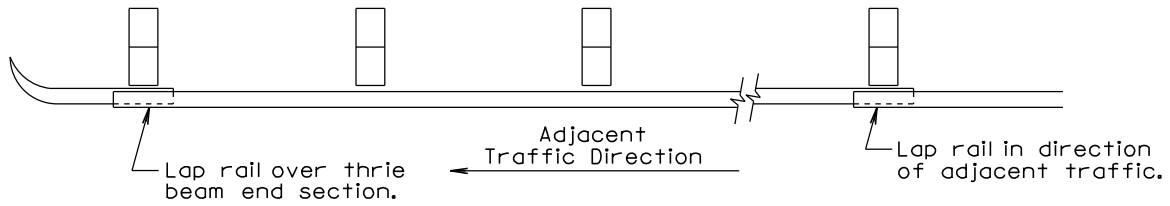

PLAN

| THRIE BEAM GUARDRAIL DEFLECTION CRITERIA | |
|--|--------------------|
| POST SPACING | MAXIMUM DEFLECTION |
| 6'-3" | 2'-6" |
| 3'-1/2" | 1'-9" |

For Informational Purposes Only

GENERAL NOTES:

All thrie beam rail shall be Type 1.

There will be no separate payment for furnishing and installing Thrie Beam End Sections (Flared) and Thrie Beam Terminal Connectors. All costs for the Thrie Beam End Sections (Flared) and Thrie Beam Terminal Connectors shall be incidental to the contract unit price per foot for the respective "Thrie Beam Guardrail" bid item.

Thrie beam rail section lengths may be 12'-6" and/or 25'-0". The combination of section lengths used shall be compatible with the total length of rail per site as shown in the plans.

Thrie Beam End Sections (Flared) shall only be used in a one way traffic situation. See Standard Plate 630.80 for Thrie Beam End Section (Flared) in the Beam Guardrail Trailing End Terminal.

All costs for constructing thrie beam guardrail including labor, equipment, and materials including all posts, blocks, steel beam rail, and hardware shall be incidental to the contract unit price per foot for the respective "Thrie Beam Guardrail" bid item.

Surfacing and embankment quantities will be paid for separately and will NOT be incidental to the "Thrie Beam Guardrail" bid item.

December 23, 2010

Published Date: 3rd Qtr. 2013

**S
D
D
O
T**

THRIE BEAM GUARDRAIL INSTALLATION

PLATE NUMBER
630.02

Sheet 1 of 1

**0001-271, 0001-272, 0001-291 & 000P-292 - GUARDRAIL REPAIR
 BON HOMME, CHARLES MIX, CLAY, HUTCHINSON, LAKE, LINCOLN, MINER,
 MINNEHAHA, MOODY, TURNER, UNION & YANKTON COUNTIES**

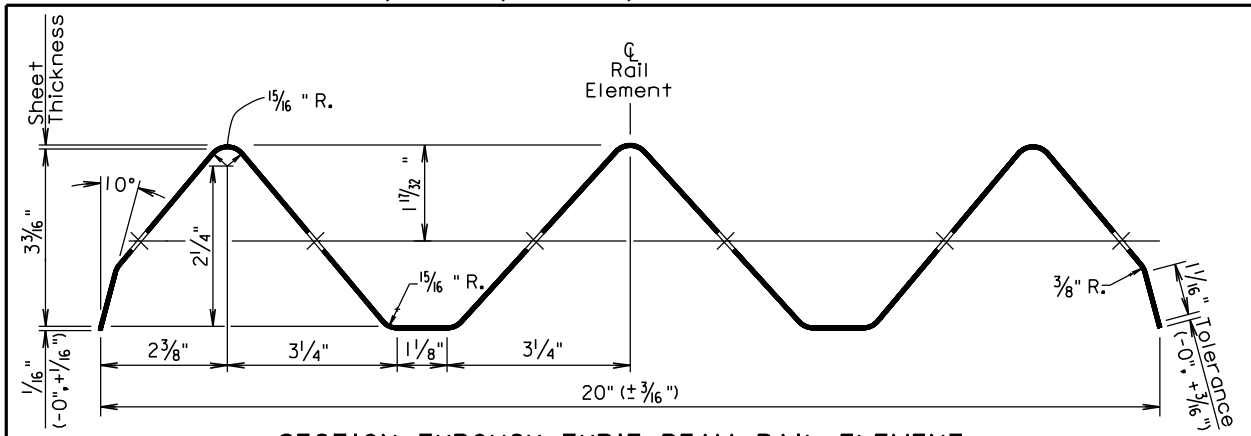

SECTION THROUGH THRIE BEAM RAIL ELEMENT

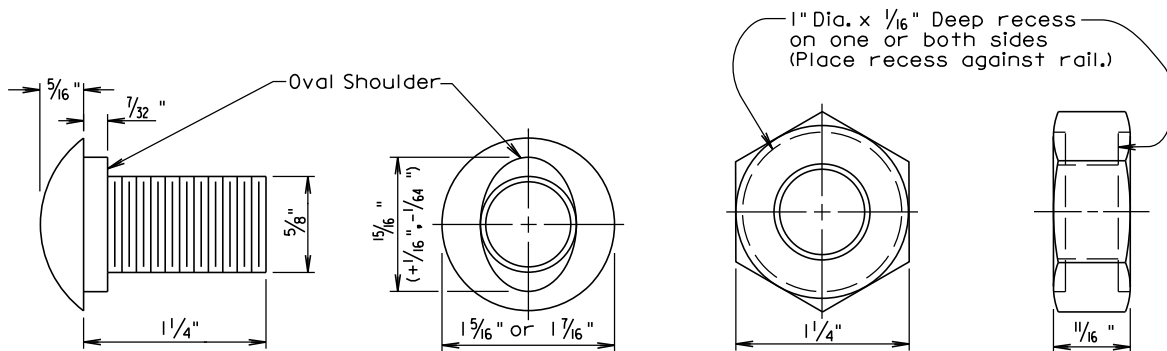

The Post Bolt is similar except the post bolt is 18" long.

**SPLICE BOLT
 (5/8" BUTTON HEAD BOLT AND RECESS NUT)**

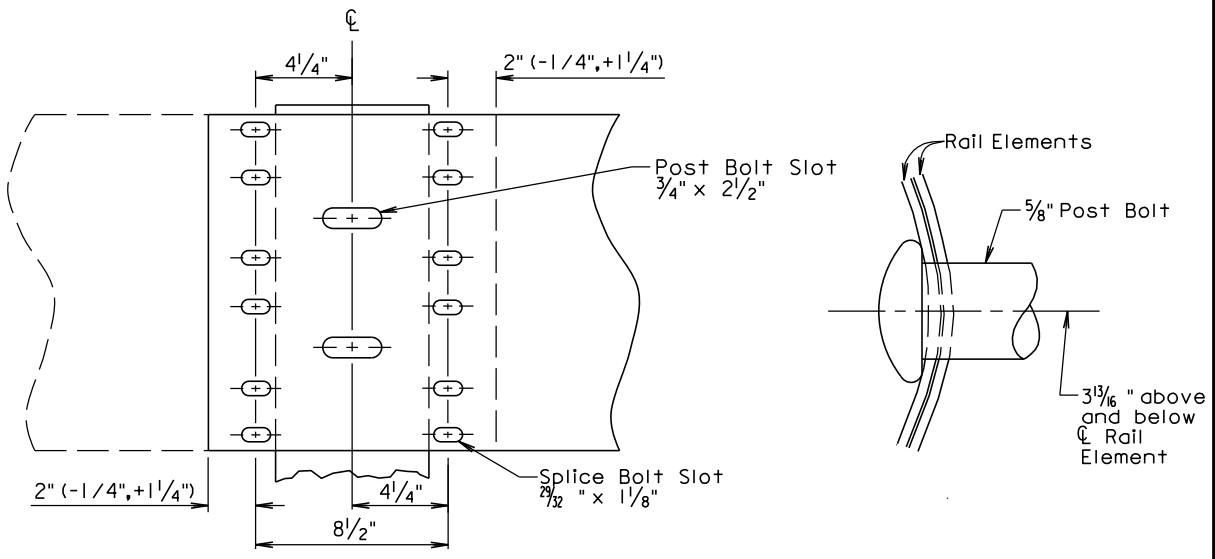

Lap in direction of traffic.

RAIL SPLICE

March 31, 2000

| | | |
|----------------------------------|---|-------------------------------|
| S D D O T | THRIE BEAM RAIL, RAIL SPLICE, AND HARDWARE | PLATE NUMBER 630.03 |
| | | Sheet 1 of 1 |

Published Date: 3rd Qtr. 2013

**0001-271, 0001-272, 0001-291 & 000P-292 - GUARDRAIL REPAIR
 BON HOMME, CHARLES MIX, CLAY, HUTCHINSON, LAKE, LINCOLN, MINER,
 MINNEHAHA, MOODY, TURNER, UNION & YANKTON COUNTIES**

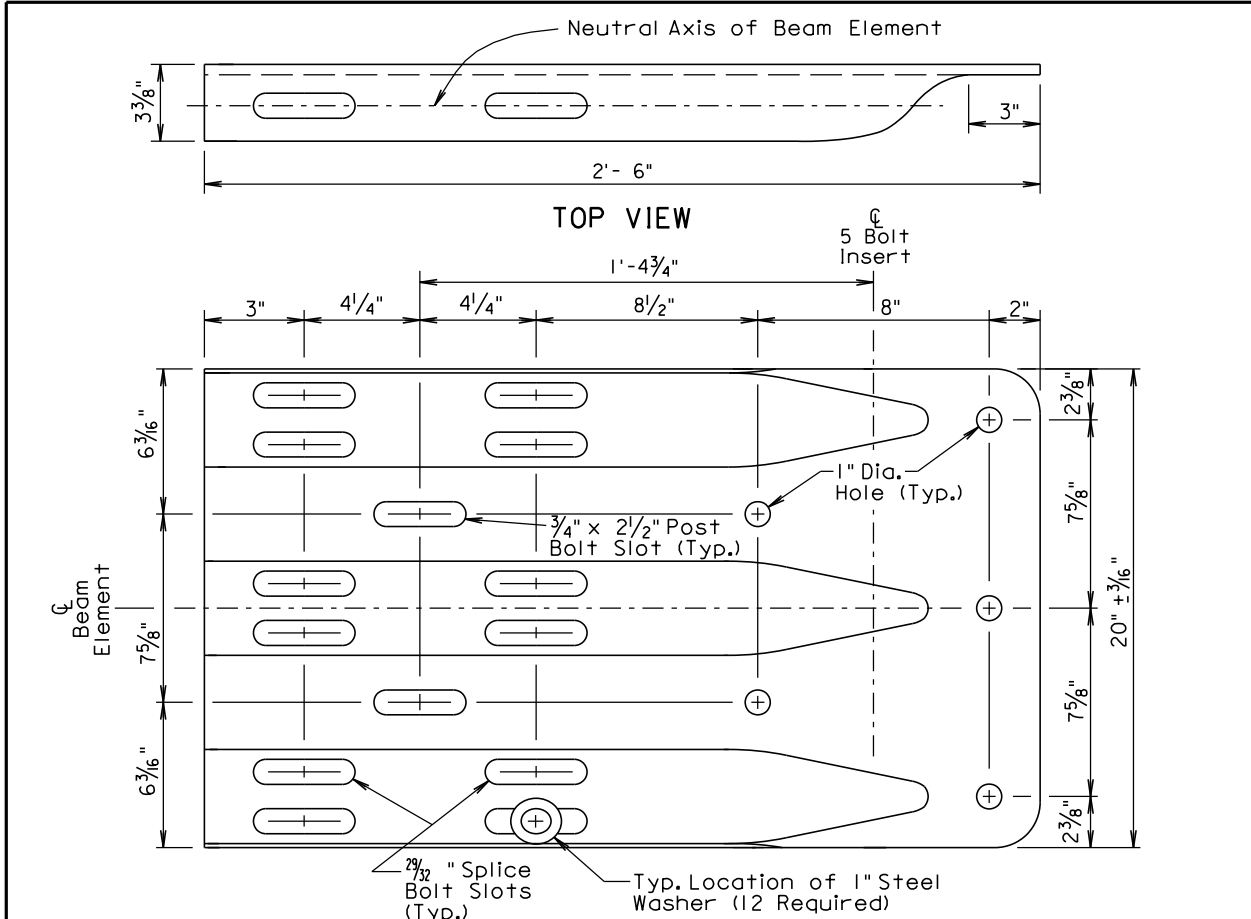

**ELEVATION
 THRIE BEAM TERMINAL CONNECTOR**

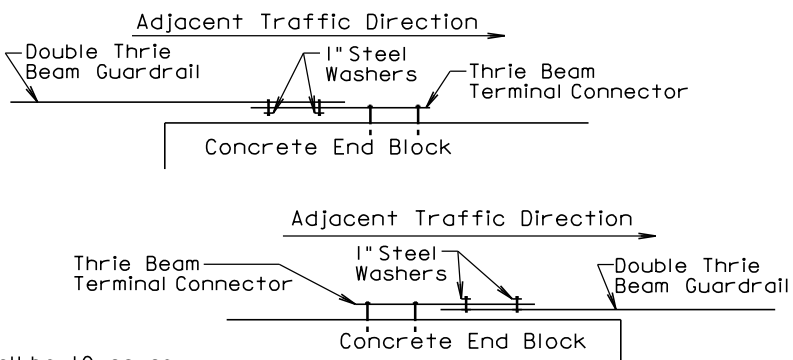
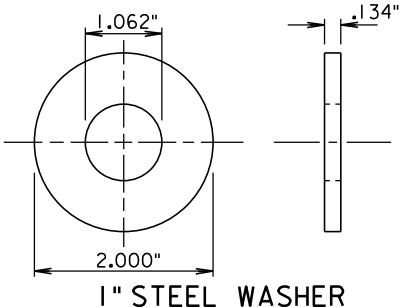

GENERAL NOTES:

Thrie Beam Terminal Connectors shall be 10 gauge.

When the thrie beam terminal connector is used to connect the rail to the bridge, 1" steel washers shall be used at the lap splice and the washers shall be in direct contact with the 3" slots of the thrie beam terminal connector. See the drawings above for the typical locations of the 1" steel washers.

There will be no separate payment for furnishing and installing the Thrie Beam Terminal Connector. All costs for the Thrie Beam Terminal Connector shall be incidental to the contract unit price per foot for the respective "Thrie Beam Guardrail" bid item.

September 14, 2001

| | | | | |
|---|---|--|--|---|
| <p><i>Published Date: 3rd Qtr. 2013</i></p> | <p>S D D O T</p> | <p>THRIE BEAM TERMINAL CONNECTOR AND 1" STEEL WASHER</p> | | <p>PLATE NUMBER 630.05</p> |
| | | | | <p>Sheet 1 of 1</p> |

**0001-271, 0001-272, 0001-291 & 000P-292 - GUARDRAIL REPAIR
 BON HOMME, CHARLES MIX, CLAY, HUTCHINSON, LAKE, LINCOLN, MINER,
 MINNEHAHA, MOODY, TURNER, UNION & YANKTON COUNTIES**

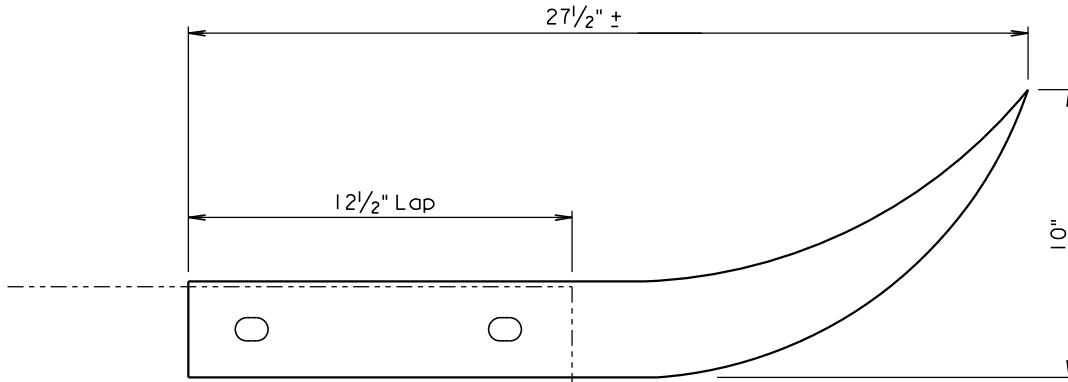

TOP VIEW

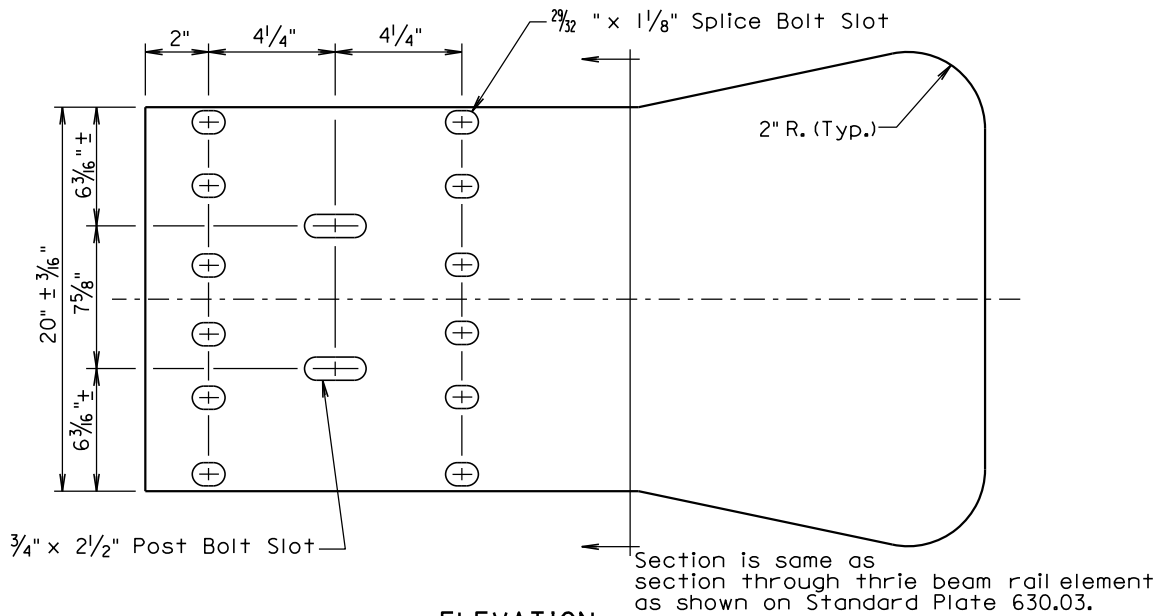

ELEVATION

GENERAL NOTES:

Thrie Beam End Sections (Flared) shall be 12 gage.

There will be no separate payment for furnishing and installing Thrie Beam End Sections (Flared). All costs for the Thrie Beam End Sections (Flared) shall be incidental to the contract unit price per foot for the respective "Thrie Beam Guardrail" bid item.

Thrie Beam End Sections (Flared) shall only be used in a one way traffic situation. See Standard Plate 630.80 for Thrie Beam End Section (Flared) in the Beam Guardrail Trailing End Terminal.

March 31, 2000

| | | | |
|--------------------------------------|----------------------------------|--|-------------------------------|
| <i>Published Date: 3rd Qtr. 2013</i> | S D D O T | THRIE BEAM END SECTION (FLARED) | PLATE NUMBER 630.10 |
| | | | Sheet 1 of 1 |

**000I-271, 000I-272, 000I-291 & 000P-292 - GUARDRAIL REPAIR
 BON HOMME, CHARLES MIX, CLAY, HUTCHINSON, LAKE, LINCOLN, MINER,
 MINNEHAHA, MOODY, TURNER, UNION & YANKTON COUNTIES**

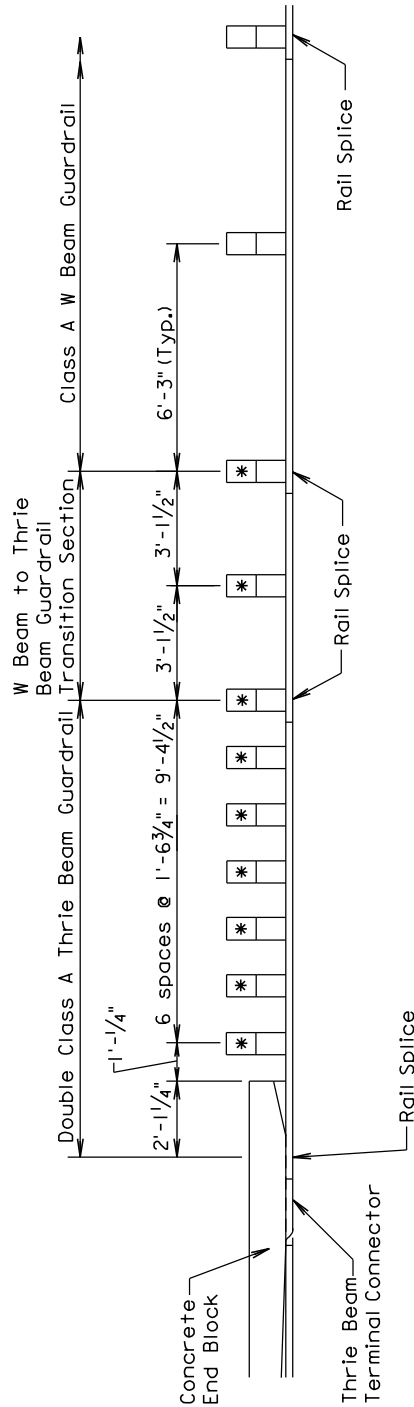

* 6" x 8" x 7' posts shall be used at these locations.

POST SPACING ARRANGEMENT FOR THRIE BEAM GUARDRAIL AT BRIDGE END

December 23, 2002

Published Date: 3rd Qtr. 2013

**S
D
D
O
T**

**POST SPACING ARRANGEMENT FOR
 THRIE BEAM GUARDRAIL AT BRIDGE END**

PLATE NUMBER
630.15

Sheet 1 of 1

**0001-271, 0001-272, 0001-291 & 000P-292 - GUARDRAIL REPAIR
 BON HOMME, CHARLES MIX, CLAY, HUTCHINSON, LAKE, LINCOLN, MINER,
 MINNEHAHA, MOODY, TURNER, UNION & YANKTON COUNTIES**

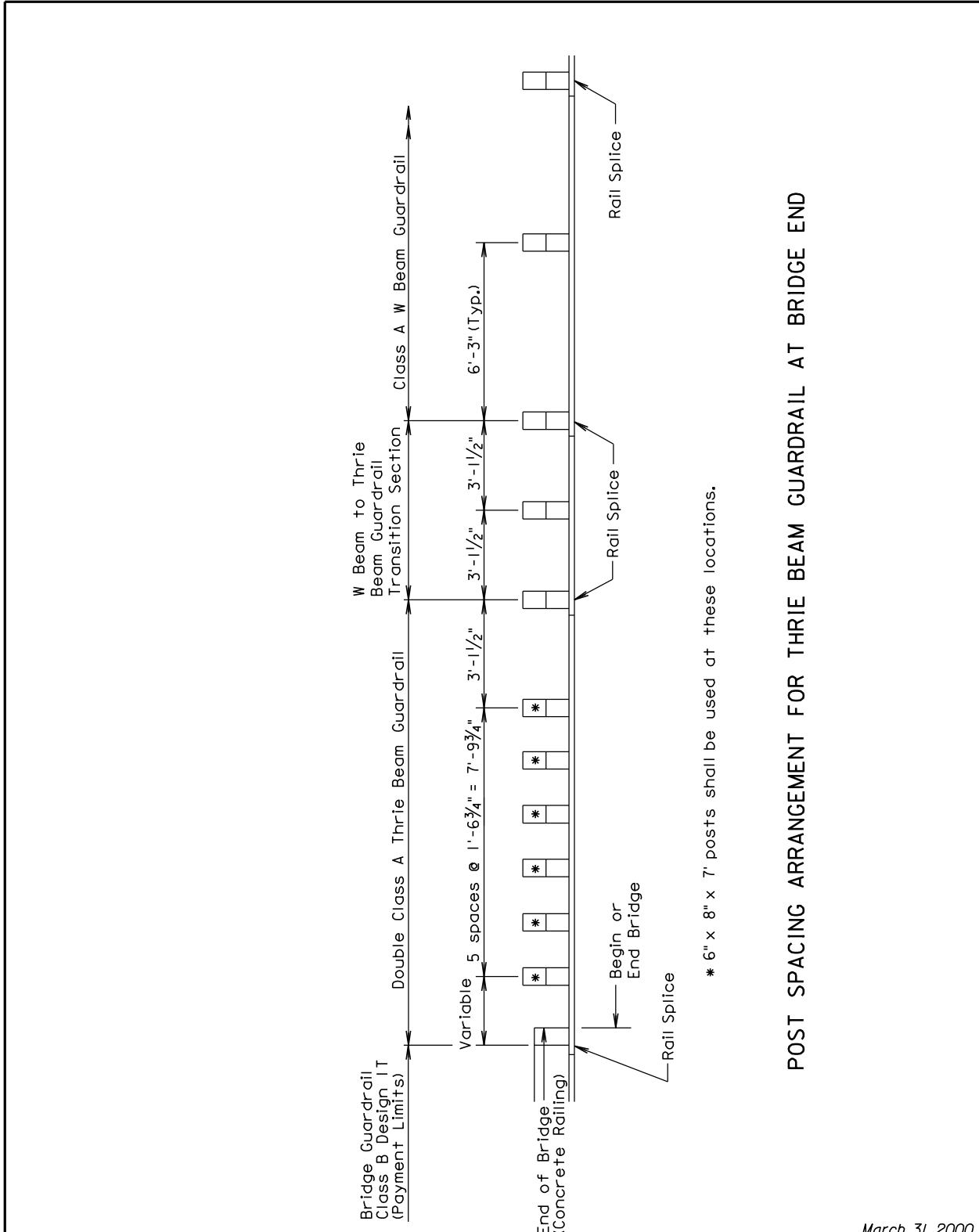

POST SPACING ARRANGEMENT FOR THRIE BEAM GUARDRAIL AT BRIDGE END

March 31, 2000

Published Date: 3rd Qtr. 2013

**S
D
D
O
T**

**POST SPACING ARRANGEMENT FOR
 THRIE BEAM GUARDRAIL AT BRIDGE END
 (BRIDGE GUARDRAIL DESIGN 1T)**

PLATE NUMBER
630.20

Sheet 1 of 1

**0001-271, 0001-272, 0001-291 & 000P-292 - GUARDRAIL REPAIR
 BON HOMME, CHARLES MIX, CLAY, HUTCHINSON, LAKE, LINCOLN, MINER,
 MINNEHAHA, MOODY, TURNER, UNION & YANKTON COUNTIES**

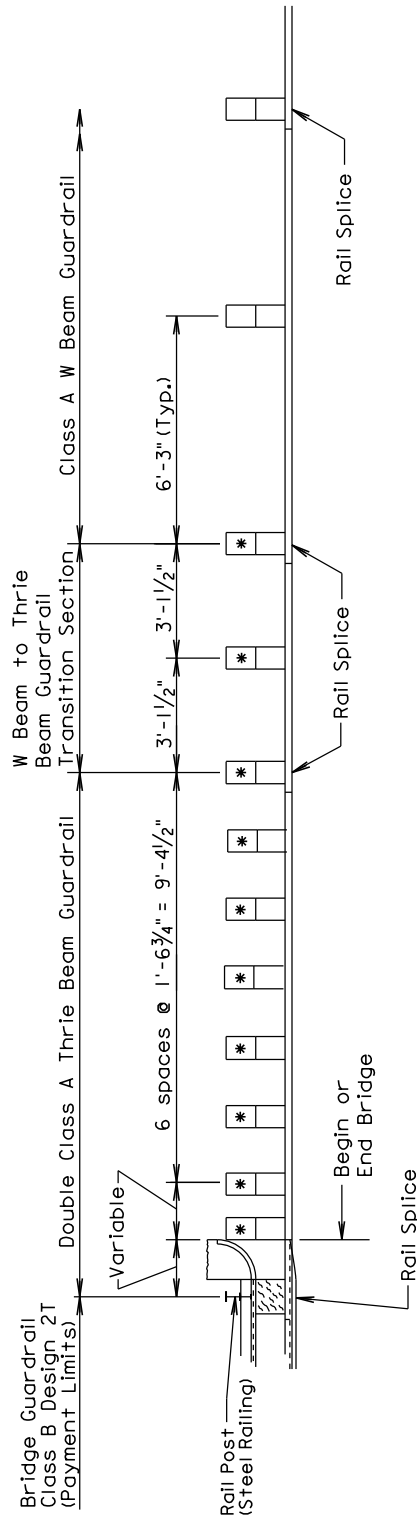

* 6" x 8" x 7' posts shall be used at these locations.

POST SPACING ARRANGEMENT FOR THRIE BEAM GUARDRAIL AT BRIDGE END

December 23, 2002

Published Date: 3rd Qtr. 2013

**S
D
D
O
T**

**POST SPACING ARRANGEMENT FOR
 THRIE BEAM GUARDRAIL AT BRIDGE END
 (BRIDGE GUARDRAIL DESIGN 2T)**

PLATE NUMBER
630.21

Sheet 1 of 1

**0001-271, 0001-272, 0001-291 & 000P-292 - GUARDRAIL REPAIR
 BON HOMME, CHARLES MIX, CLAY, HUTCHINSON, LAKE, LINCOLN, MINER,
 MINNEHAHA, MOODY, TURNER, UNION & YANKTON COUNTIES**

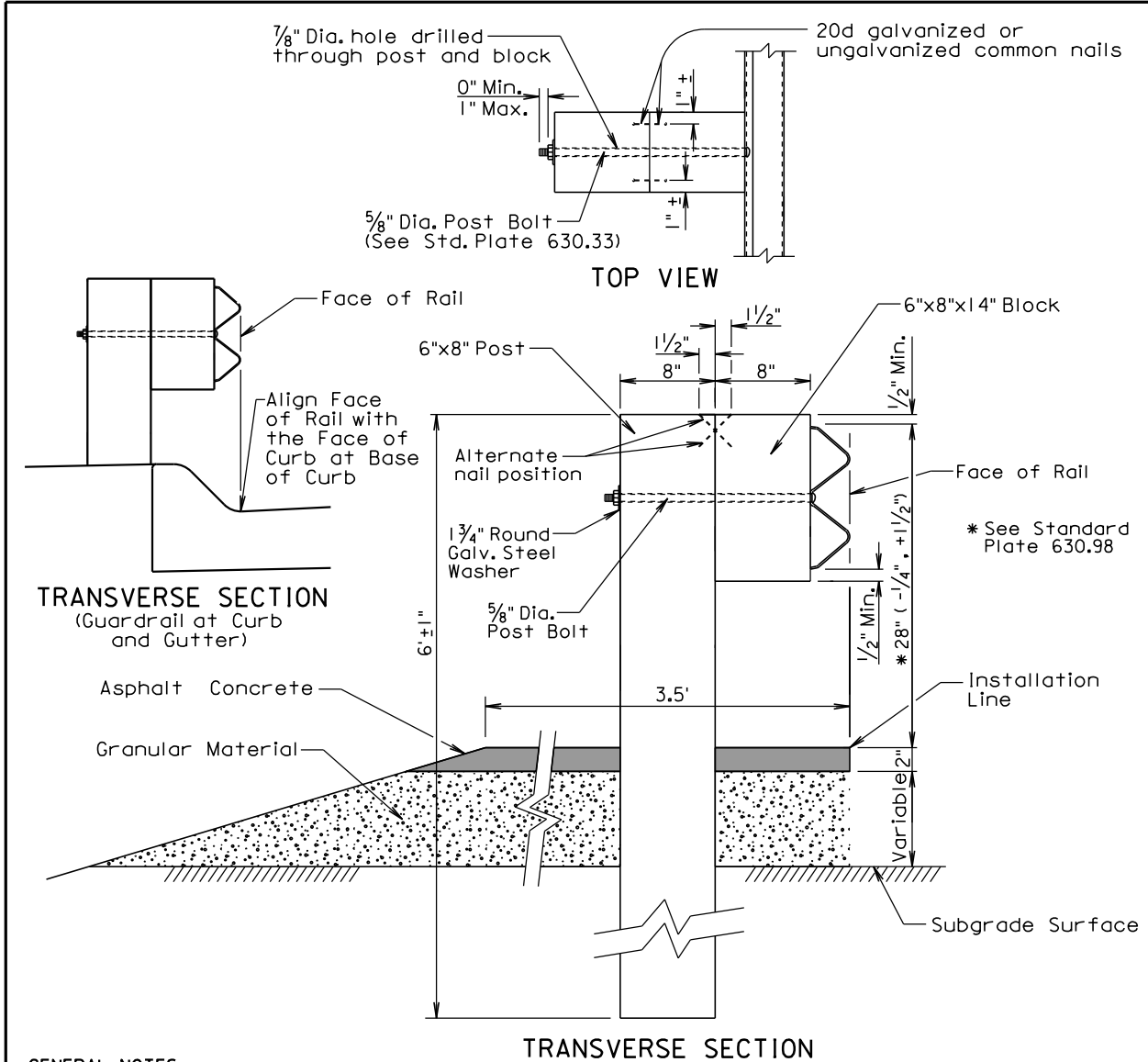

GENERAL NOTES:

Asphalt concrete shall be the same type used elsewhere on the project or shall be as specified in the plans. If asphalt concrete is not specified in the plans, the asphalt concrete shall conform to the SD Standard Specifications for "Asphalt Concrete Composite." For informational purposes, the Rate of Materials for the 3.5' wide section of asphalt concrete as shown above shall be 4.80 Tons per Station.

Granular material shall be the same type used elsewhere on the project or shall be as specified in the plans. If granular material type is not specified in the plans, the material shall conform to the SD Standard Specifications for "Base Course". The granular material shall be placed the same thickness as the mainline surfacing or as specified in the plans.

Surfacing and embankment quantities will be paid for separately and will NOT be incidental to the "W Beam Guardrail" bid item.

The cross slope for the surfacing and subgrade surface shall be as specified in the plans (See Typical Sections and/or Cross Sections).

The top of posts and top of block shall have a true square cut. The top of post and top of block shall be flush.

December 23, 2010

| | | |
|-------------------|---|-------------------------------|
| SD DOT | W BEAM GUARDRAIL POST INSTALLATION | PLATE NUMBER 630.31 |
| | | Sheet 1 of 1 |

Published Date: 3rd Qtr. 2013

**0001-271, 0001-272, 0001-291 & 000P-292 - GUARDRAIL REPAIR
 BON HOMME, CHARLES MIX, CLAY, HUTCHINSON, LAKE, LINCOLN, MINER,
 MINNEHAHA, MOODY, TURNER, UNION & YANKTON COUNTIES**

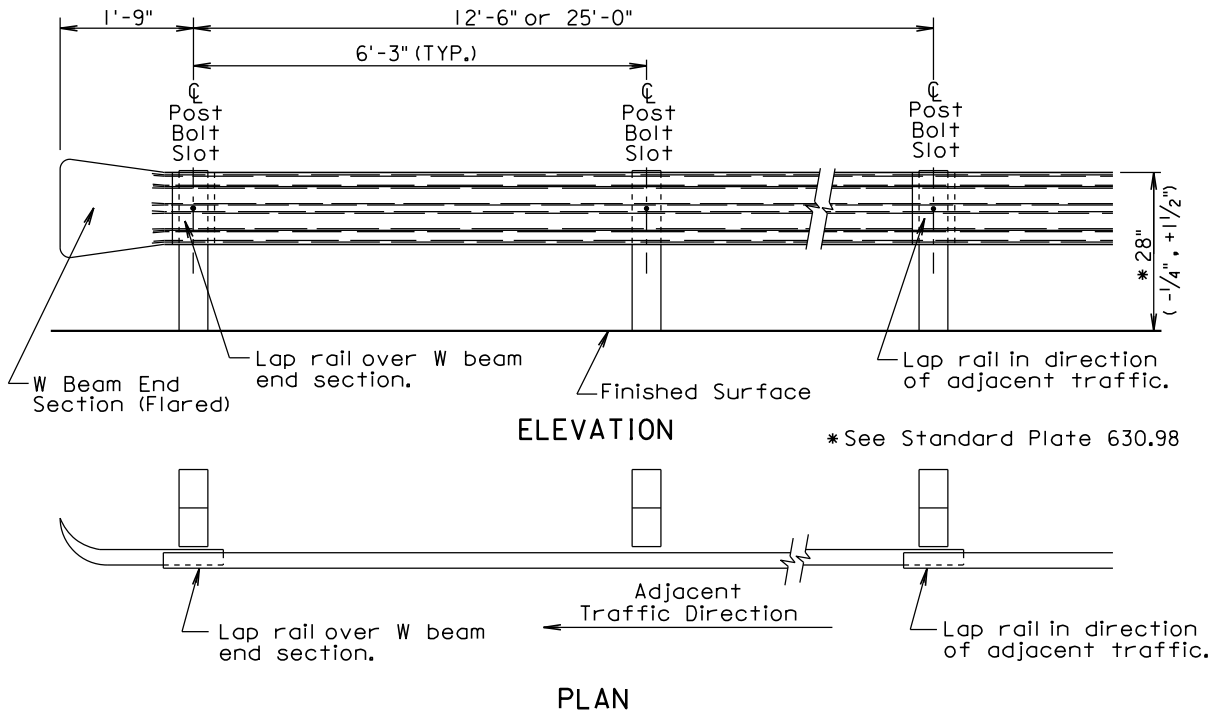

| W BEAM GUARDRAIL DEFLECTION CRITERIA | |
|--------------------------------------|--------------------|
| POST SPACING | MAXIMUM DEFLECTION |
| 6'-3" | 3'-3" |
| 3'-1 1/2" | 2'-0" |

For Informational Purposes Only

GENERAL NOTES:

All W beam rail shall be Type 1.

There will be no separate payment for furnishing and installing W Beam End Sections (Flared) and W Beam Terminal Connectors. All costs for the W Beam End Sections (Flared) and W Beam Terminal Connectors shall be incidental to the contract unit price per foot for the respective "W Beam Guardrail" bid item.

W beam rail section lengths may be 12'-6" and/or 25'-0". The combination of section lengths used shall be compatible with the total length of rail per site as shown in the plans.

W Beam End Sections (Flared) shall only be used in a one way traffic situation. See Standard Plate 630.80 for W Beam End Section (Flared) in the Beam Guardrail Trailing End Terminal.

All costs for constructing W beam guardrail including labor, equipment, and materials including all posts, blocks, steel beam rail, and hardware shall be incidental to the contract unit price per foot for the respective "W Beam Guardrail" bid item.

Surfacing and embankment quantities will be paid for separately and will NOT be incidental to the "W Beam Guardrail" bid item.

December 23, 2010

| | | | |
|--------------------------------------|----------------------------------|--------------------------------------|-------------------------------|
| <i>Published Date: 3rd Qtr. 2013</i> | S D D O T | W BEAM GUARDRAIL INSTALLATION | PLATE NUMBER 630.32 |
| | | | Sheet 1 of 1 |

**0001-271, 0001-272, 0001-291 & 000P-292 - GUARDRAIL REPAIR
 BON HOMME, CHARLES MIX, CLAY, HUTCHINSON, LAKE, LINCOLN, MINER,
 MINNEHAHA, MOODY, TURNER, UNION & YANKTON COUNTIES**

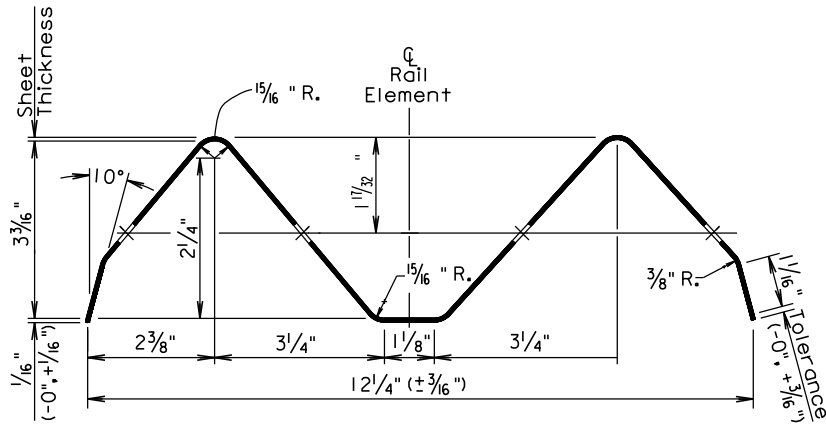

SECTION THROUGH W BEAM RAIL ELEMENT

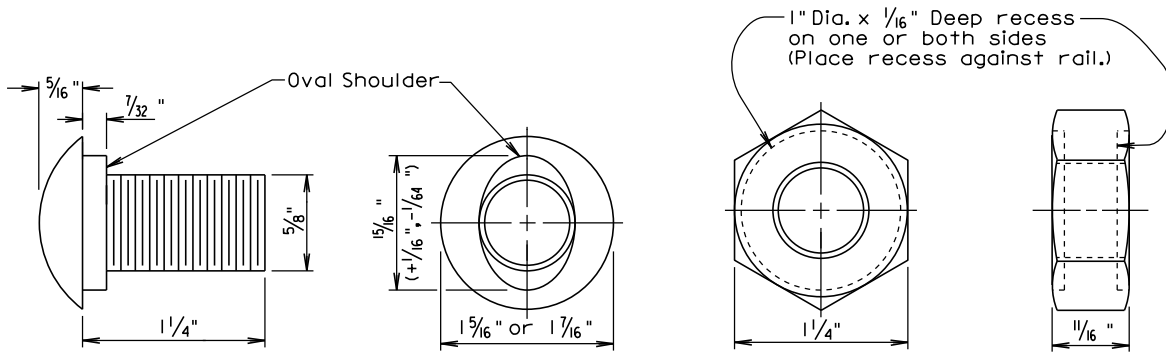

The Post Bolt is similar except the post bolt is 18" long.

**SPLICE BOLT
 (5/8" BUTTON HEAD BOLT AND RECESS NUT)**

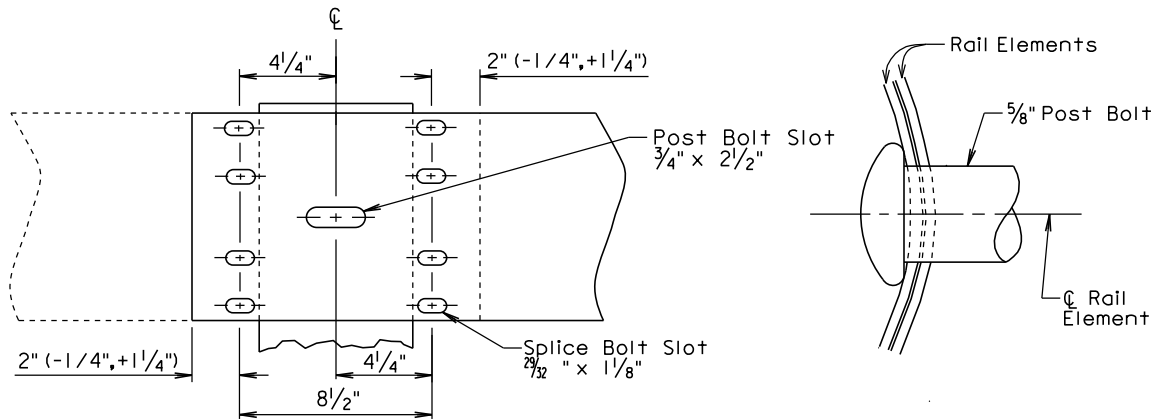

Lap in direction of traffic.
RAIL SPLICE

December 23, 2004

Published Date: 3rd Qtr. 2013

**S
D
D
O
T**

W BEAM RAIL, RAIL SPLICE, AND HARDWARE

**PLATE NUMBER
 630.33**

Sheet 1 of 1

**0001-271, 0001-272, 0001-291 & 000P-292 - GUARDRAIL REPAIR
 BON HOMME, CHARLES MIX, CLAY, HUTCHINSON, LAKE, LINCOLN, MINER,
 MINNEHAHA, MOODY, TURNER, UNION & YANKTON COUNTIES**

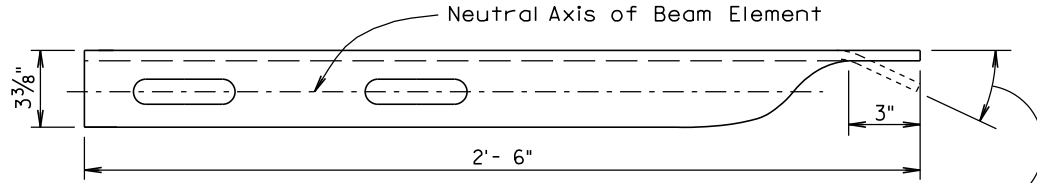

An extra hole and an approximate 26° bend shall be required only for the Breakaway Cable Terminal. The Modified W Beam Terminal Connector placement detail is shown on Standard Plate 630.47.

TOP VIEW

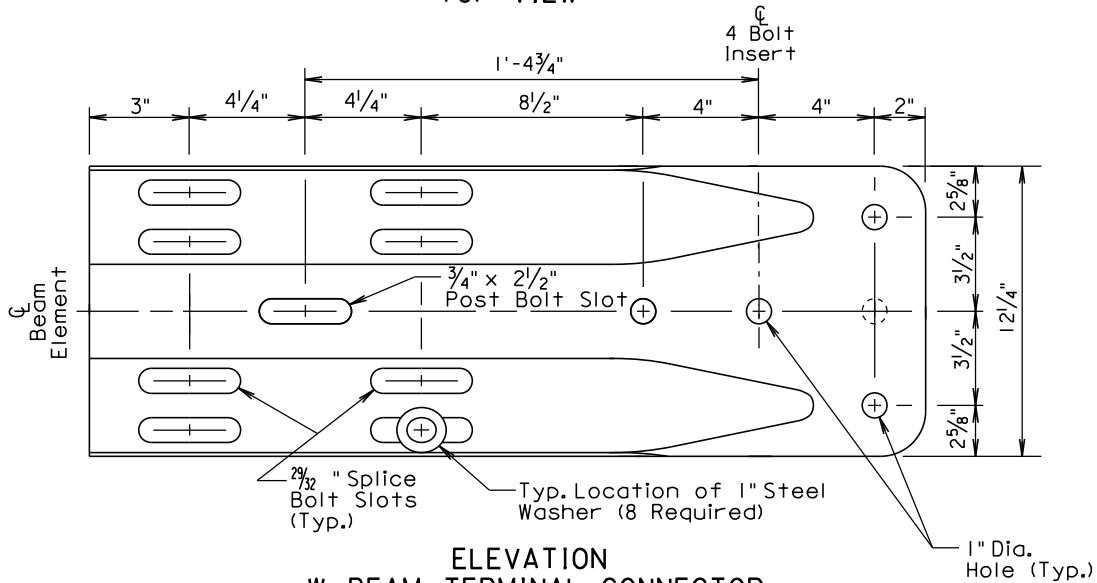

**ELEVATION
 W BEAM TERMINAL CONNECTOR**

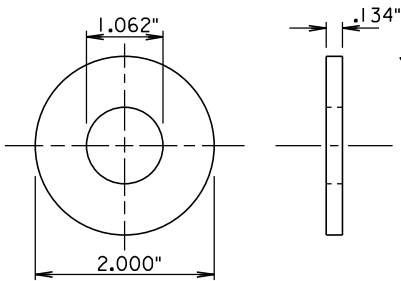

1" STEEL WASHER

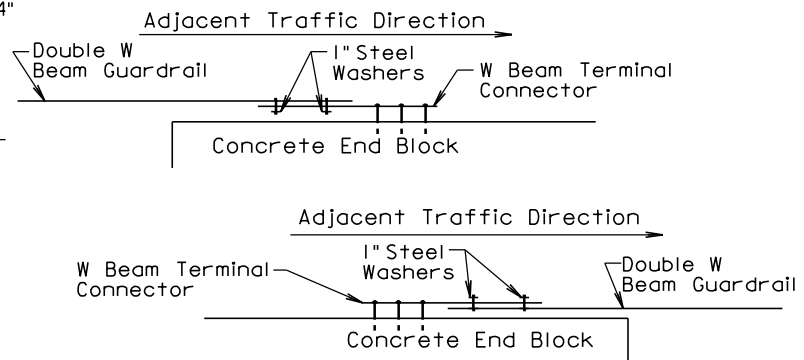

GENERAL NOTES:

W Beam Terminal Connectors shall be 10 gauge.

When the W beam terminal connector is used to connect the rail to the bridge, 1" steel washers shall be used at the lap splice and the washers shall be in direct contact with the 3" slots of the W beam terminal connector. See the drawings above for the typical locations of the 1" steel washers.

There will be no separate payment for furnishing and installing the W Beam Terminal Connector. All costs for the W Beam Terminal Connector shall be incidental to the contract unit price per foot for the respective "W Beam Guardrail" bid item.

September 14, 2001

Published Date: 3rd Qtr. 2013

**S
D
D
O
T**

**W BEAM TERMINAL CONNECTOR
 AND 1" STEEL WASHER**

**PLATE NUMBER
 630.35**

Sheet 1 of 1

**0001-271, 0001-272, 0001-291 & 000P-292 - GUARDRAIL REPAIR
 BON HOMME, CHARLES MIX, CLAY, HUTCHINSON, LAKE, LINCOLN, MINER,
 MINNEHAHA, MOODY, TURNER, UNION & YANKTON COUNTIES**

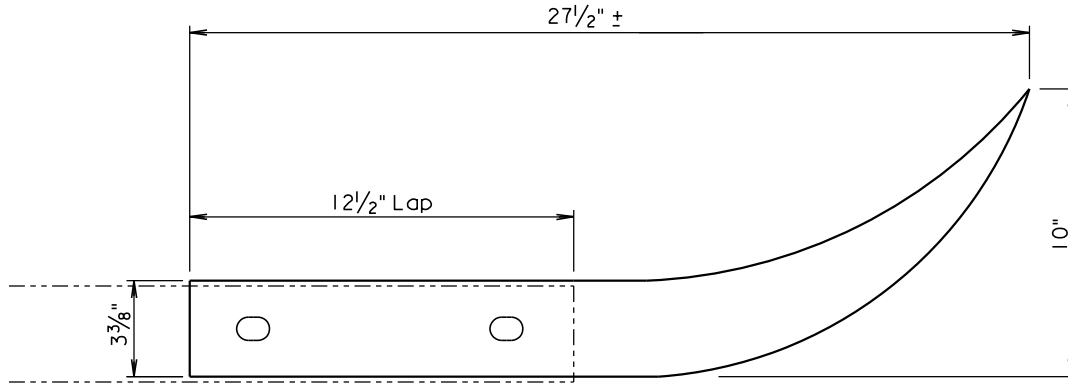

TOP VIEW

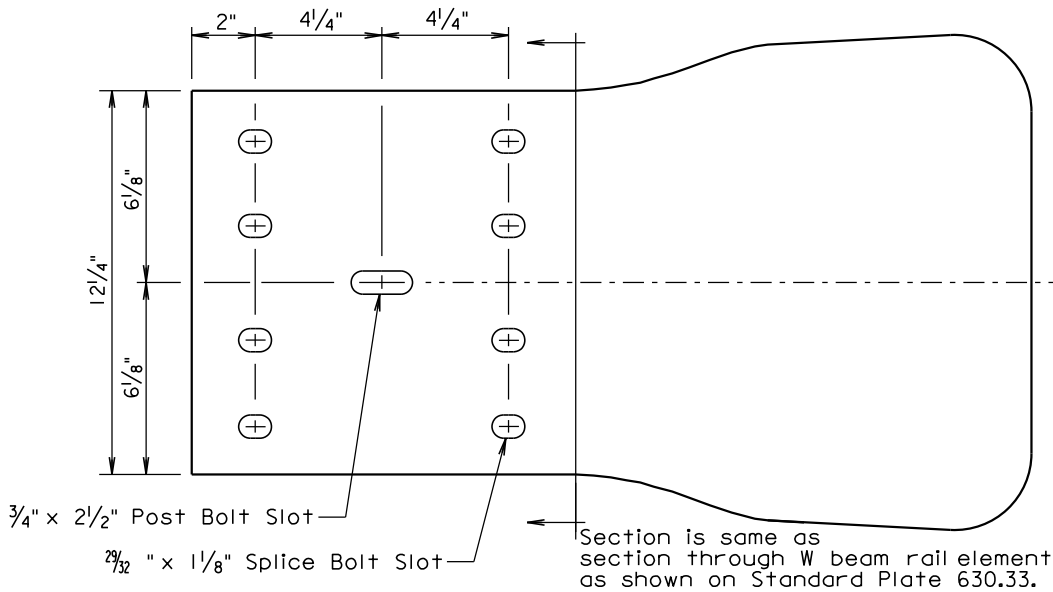

ELEVATION

GENERAL NOTES:

W Beam End Sections (Flared) shall be 12 gage.

There will be no separate payment for furnishing and installing W Beam End Sections (Flared). All costs for the W Beam End Sections (Flared) shall be incidental to the contract unit price per foot for the respective "W Beam Guardrail" bid item.

W Beam End Sections (Flared) shall only be used in a one way traffic situation. See Standard Plate 630.80 for W Beam End Section (Flared) in the Beam Guardrail Trailing End Terminal.

March 31, 2000

| | | | |
|--------------------------------------|----------------------------------|------------------------------------|-------------------------------|
| <i>Published Date: 3rd Qtr. 2013</i> | S D D O T | W BEAM END SECTION (FLARED) | PLATE NUMBER 630.40 |
| | | | Sheet 1 of 1 |

**0001-271, 0001-272, 0001-291 & 000P-292 - GUARDRAIL REPAIR
 BON HOMME, CHARLES MIX, CLAY, HUTCHINSON, LAKE, LINCOLN, MINER,
 MINNEHAHA, MOODY, TURNER, UNION & YANKTON COUNTIES**

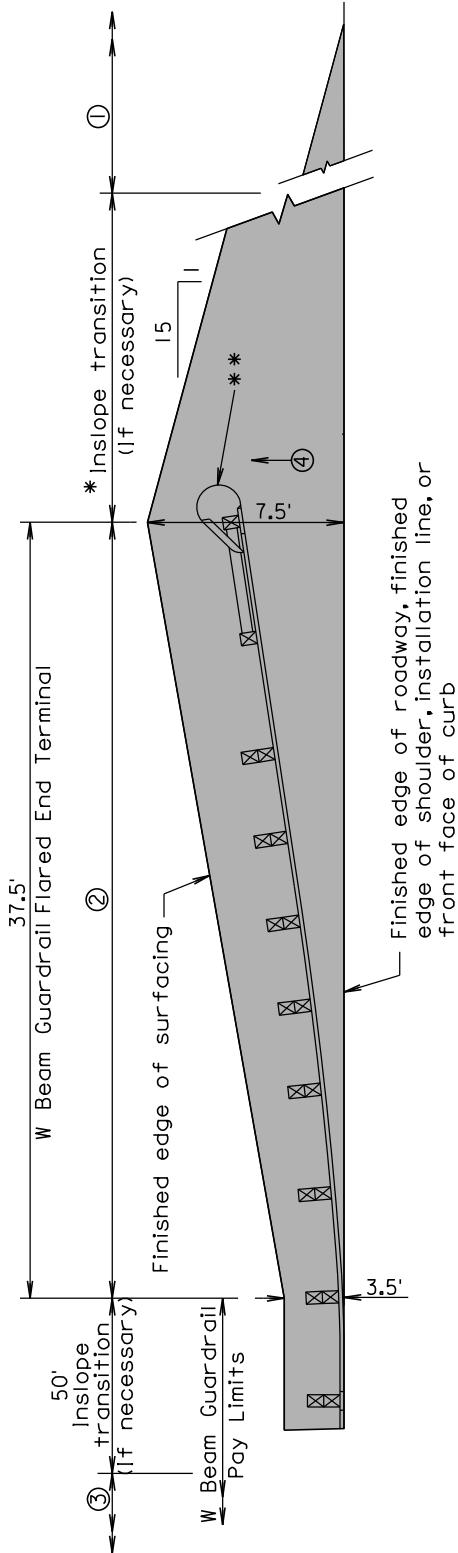

- PLAN**
- ① 2" Asphalt concrete surfacing with variable thickness granular material
 - ② Same inslope as mainline inslope
 - ③ 4:1 inslope
 - ④ 2:1 inslope or flatter, or inslope as specified in plans
 - ⑤ Same slope as roadway cross slope
- * The length of inslope transition varies with the amount of change between inslopes. The length of the transition shall change 100' for every whole number change in the inslope. For Example: If the inslope changes from a 5:1 to a 4:1 the length of the inslope transition would be 100'. If the inslope changes from a 6:1 to a 4:1 the length of the inslope transition would be 200'.

GENERAL NOTES:

The W beam guardrail flared end terminal shall be installed according to the manufacturer's installation instructions.

** An adhesive object marker shall be placed on the end section buffer or extruder after placement of the end section buffer or extruder. The adhesive object marker dimensions may be 16" x 16" or other variation due to the shape of the end section buffer or extruder. A minimum of 256 square inches of object marker reflective sheeting area is required. The reflective sheeting shall be fluorescent yellow super or very high intensity. All costs for furnishing and installing the adhesive object marker shall be incidental to various contract items.

Asphalt concrete shall be the same type used elsewhere on the project or shall be as specified in the plans. If asphalt concrete is not specified in the plans, the asphalt concrete shall conform to the SD Standard Specifications for "Asphalt Concrete Composite."

Granular material shall be the same type used elsewhere on the project or shall be as specified in the plans. If granular material type is not specified in the plans, the material shall conform to the SD Standard Specifications for "Base Course". The granular material shall be placed the same thickness as the mainline surfacing or as specified in the plans.

September 6, 2009

Published Date: 3rd Qtr. 2013

SD DOT

**EMBANKMENT AND SURFACING FOR
 W BEAM GUARDRAIL FLARED END TERMINAL**

PLATE NUMBER
630.45

Sheet 1 of 1

**0001-271, 0001-272, 0001-291 & 000P-292 - GUARDRAIL REPAIR
 BON HOMME, CHARLES MIX, CLAY, HUTCHINSON, LAKE, LINCOLN, MINER,
 MINNEHAHA, MOODY, TURNER, UNION & YANKTON COUNTIES**

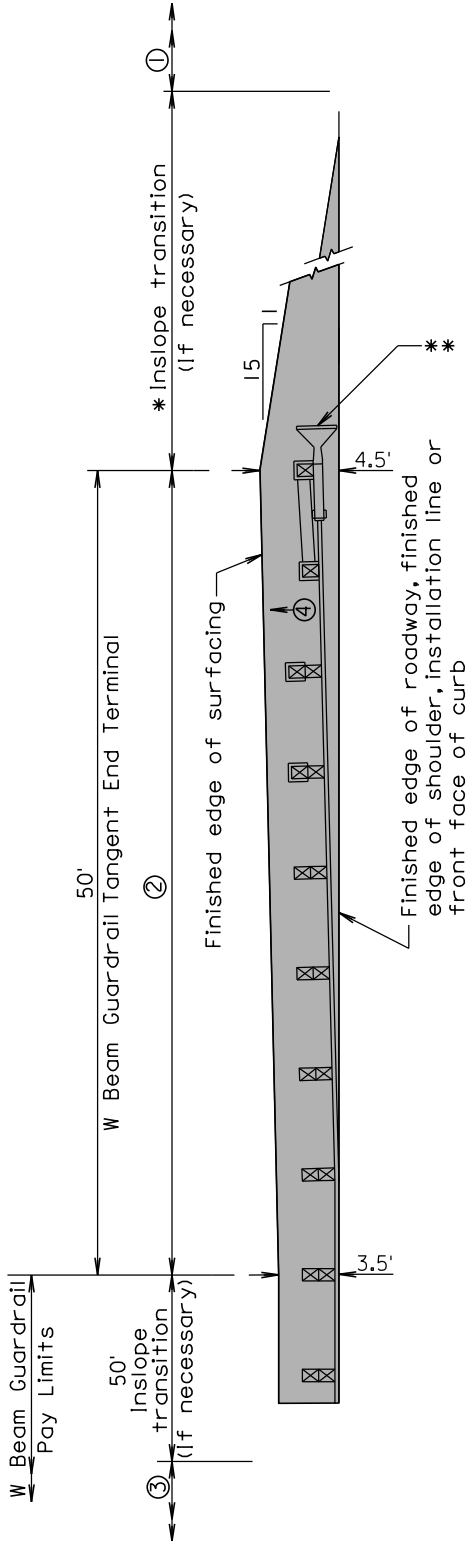

PLAN

■ 2" Asphalt concrete surfacing with variable thickness granular material

- ① Same inslope as mainline inslope
- ② 4:1 inslope
- ③ 2:1 inslope or flatter, or inslope as specified in plans
- ④ Same slope as roadway cross slope

* The length of inslope transition varies with the amount of change between inslopes. The length of the transition shall change 100' for every whole number change in the inslope. For Example: If the inslope changes from a 5:1 to a 4:1 the length of the inslope transition would be 100'. If the inslope changes from a 6:1 to a 4:1 the length of the inslope transition would be 200'.

GENERAL NOTES:

The W beam guardrail tangent end terminal shall be installed according to the manufacturer's installation instructions.

**An adhesive object marker shall be placed on the end section buffer or extruder after placement of the end section buffer or extruder. The adhesive object marker dimensions may be 16" x 16" or other variation due to the shape of the end section buffer or extruder. A minimum of 256 square inches of object marker reflective sheeting area is required. The reflective sheeting shall be fluorescent yellow super or very high intensity. All costs for furnishing and installing the adhesive object marker shall be incidental to various contract items.

Asphalt concrete shall be the same type used elsewhere on the project or shall be as specified in the plans. If asphalt concrete is not specified in the plans, the asphalt concrete shall conform to the SD Standard Specifications for "Asphalt Concrete Composite."

Granular material shall be the same type used elsewhere on the project or shall be as specified in the plans. If granular material type is not specified in the plans, the material shall conform to the SD Standard Specifications for "Base Course". The granular material shall be placed the same thickness as the mainline surfacing or as specified in the plans.

September 6, 2009

Published Date: 3rd Qtr. 2013

**S
D
D
O
T**

**EMBANKMENT AND SURFACING FOR
 W BEAM GUARDRAIL TANGENT END TERMINAL**

PLATE NUMBER
 630.46

Sheet 1 of 1

**0001-271, 0001-272, 0001-291 & 000P-292 - GUARDRAIL REPAIR
 BON HOMME, CHARLES MIX, CLAY, HUTCHINSON, LAKE, LINCOLN, MINER,
 MINNEHAHA, MOODY, TURNER, UNION & YANKTON COUNTIES**

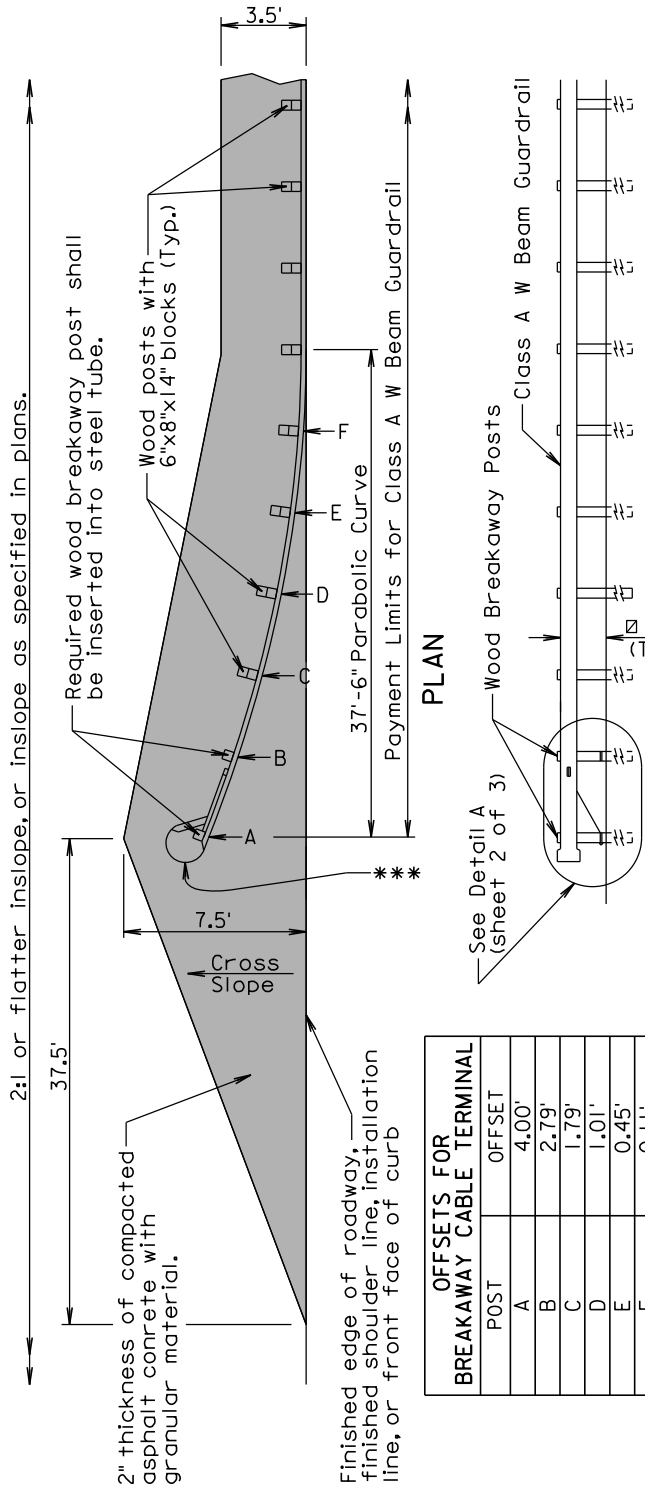

| OFFSETS FOR BREAKAWAY CABLE TERMINAL | |
|--------------------------------------|--------|
| POST | OFFSET |
| A | 4.00' |
| B | 2.79' |
| C | 1.79' |
| D | 1.01' |
| E | 0.45' |
| F | 0.11' |

Offsets shall be measured from the installation line to the face of the W beam guardrail.

GENERAL NOTES:

The finished embankment surfacing cross slope shall match the roadway cross slope; however, if a steeper cross slope is necessary the steepest allowable cross slope is 10:1.

Asphalt concrete shall be the same type used elsewhere on the project or shall be as specified in the plans. If asphalt concrete is not specified in the plans, the asphalt concrete shall conform to the SD Standard Specifications for "Asphalt Concrete Composite."

Granular material shall be the same type used elsewhere on the project or shall be as specified in the plans. If granular material type is not specified in the plans, the material shall conform to the SD Standard Specifications for "Base Course". The granular material shall be placed the same thickness as the mainline surfacing or as specified in the plans.

**An adhesive object marker shall be placed on the end section buffer after placement of the end section buffer. The adhesive object marker dimensions may be 16" x 16" or other variation due to the shape of the end section buffer. A minimum of 236 square inches of object marker reflective sheeting area is required. The reflective sheeting shall be fluorescent yellow super or very high intensity. All costs for furnishing and installing the adhesive object marker shall be incidental to various contract items.

Costs for constructing the W Beam Guardrail Breakaway Cable Terminal including labor, equipment, and materials including the anchor bracket, cable assembly, steel tubes, soil plates, bearing plate, pipe sleeve, W beam end section (buffer), modified W beam terminal connector, and all necessary hardware shall be incidental to the contract unit price per each for "W Beam Guardrail Breakaway Cable Terminal".

Published Date: 3rd Qtr. 2013

DOT

**W BEAM GUARDRAIL
 BREAKAWAY CABLE TERMINAL**

PLATE NUMBER
630.47

Sheet 1 of 3

June 26, 2010

**0001-271, 0001-272, 0001-291 & 000P-292 - GUARDRAIL REPAIR
 BON HOMME, CHARLES MIX, CLAY, HUTCHINSON, LAKE, LINCOLN, MINER,
 MINNEHAHA, MOODY, TURNER, UNION & YANKTON COUNTIES**

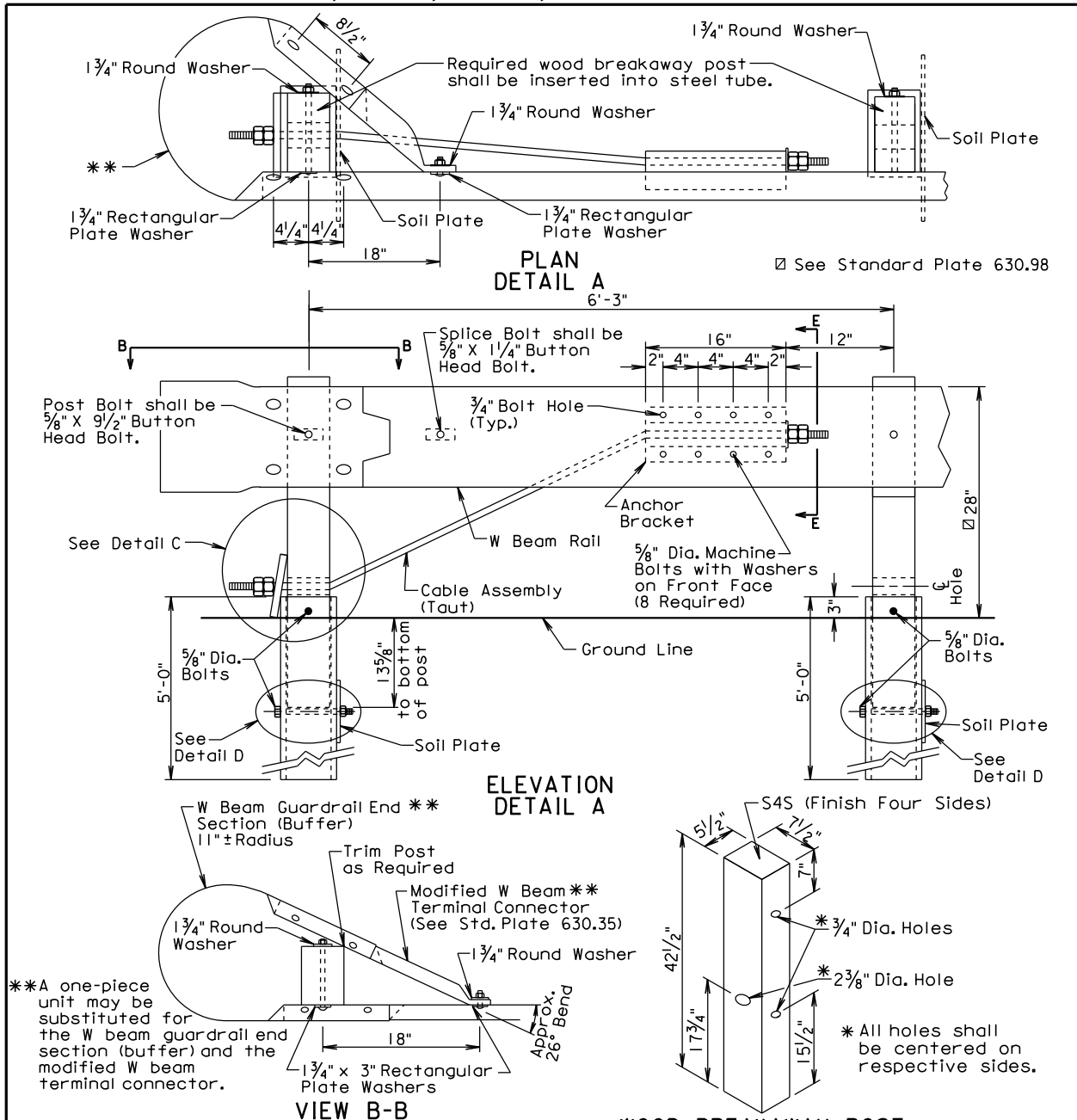

GENERAL NOTES:

- All hardware shall be galvanized in accordance with ASTM A153.
- The steel tubes shall meet the requirements of ASTM Specification A500, Grade B, and shall be galvanized after fabrication in accordance with the requirements of AASHTO Specification M111.
- The anchor bracket, soil plate, and bearing plate shall be fabricated from steel that meets ASTM A36 Specifications. They shall be galvanized after fabrication in accordance with ASTM A123.
- The W Beam End Section (Buffer) shall be 12 gage galvanized steel.
- The cable shall be 3/4", Type II, with Class A coating in conformance with AASHTO M30.

June 26, 2010

| | | | |
|---|---|---|---------------------------------------|
| <p><i>Published Date: 3rd Qtr. 2013</i></p> | <p>S D D O T</p> | <p>W BEAM GUARDRAIL BREAKAWAY CABLE TERMINAL</p> | <p>PLATE NUMBER 630.47</p> |
| | | | <p>Sheet 2 of 3</p> |

**0001-271, 0001-272, 0001-291 & 000P-292 - GUARDRAIL REPAIR
 BON HOMME, CHARLES MIX, CLAY, HUTCHINSON, LAKE, LINCOLN, MINER,
 MINNEHAHA, MOODY, TURNER, UNION & YANKTON COUNTIES**

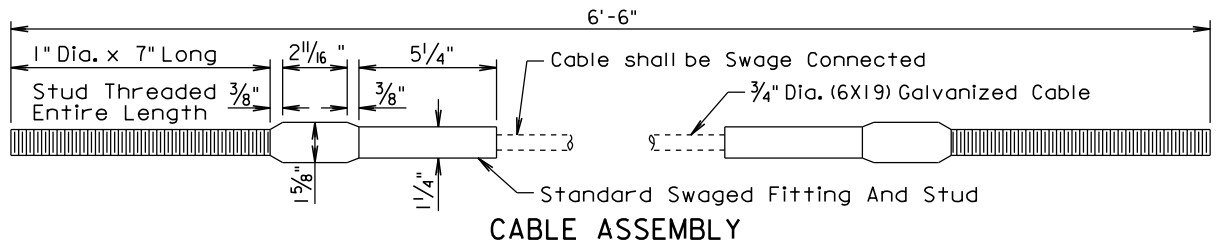
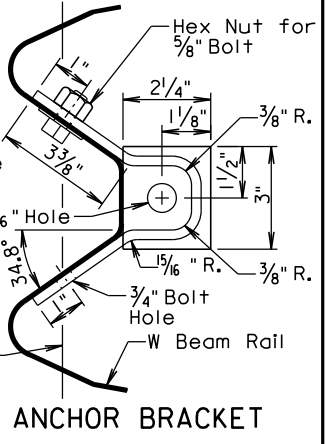
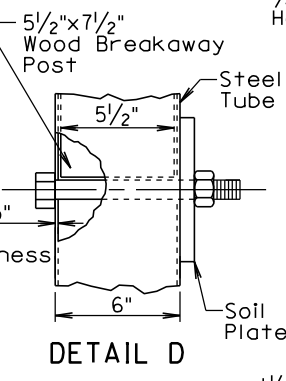
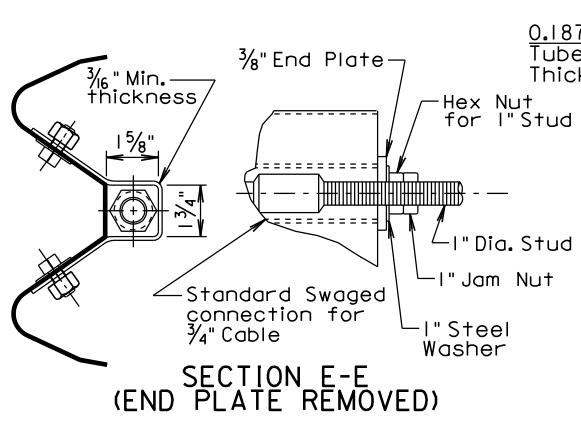
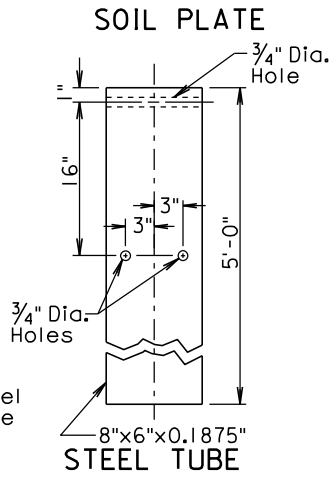
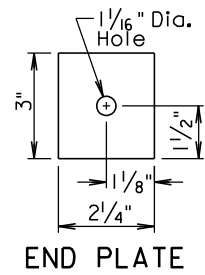
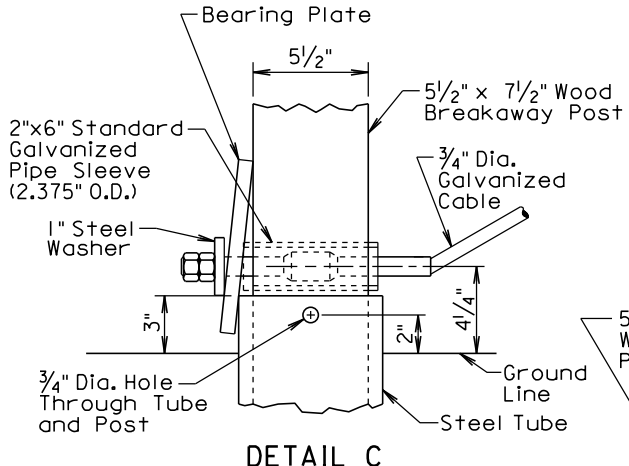
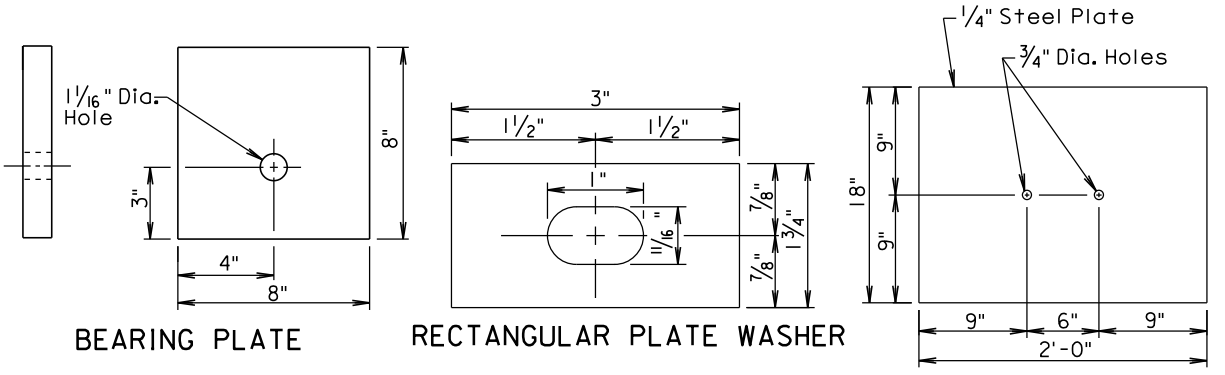

June 26, 2010

| | | | |
|-------------------------------|-----------------------|--|------------------------|
| Published Date: 3rd Qtr. 2013 | S D D O T | W BEAM GUARDRAIL BREAKAWAY CABLE TERMINAL | PLATE NUMBER 630.47 |
| | | | Sheet 3 of 3 |

**0001-271, 0001-272, 0001-291 & 000P-292 - GUARDRAIL REPAIR
 BON HOMME, CHARLES MIX, CLAY, HUTCHINSON, LAKE, LINCOLN, MINER,
 MINNEHAHA, MOODY, TURNER, UNION & YANKTON COUNTIES**

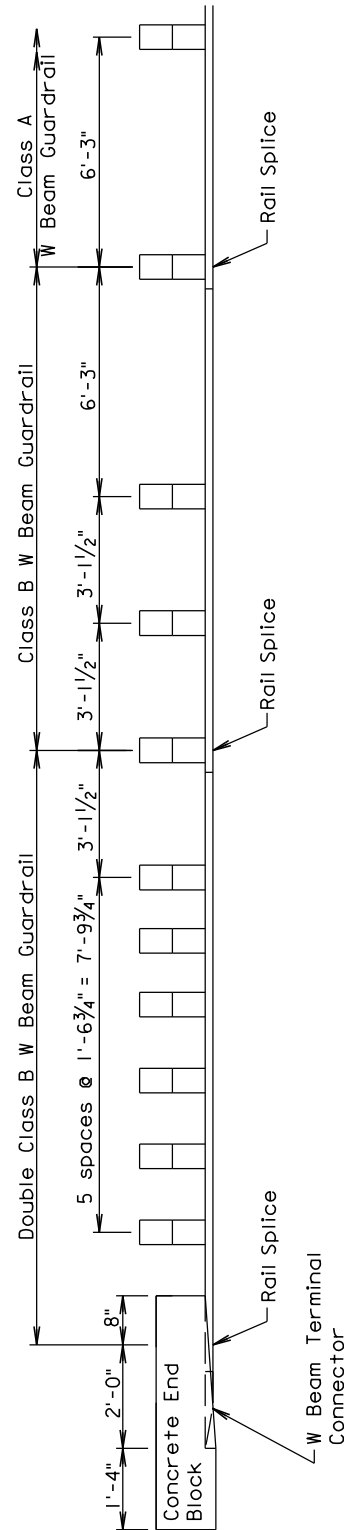

POST SPACING ARRANGEMENT FOR W BEAM GUARDRAIL AT BRIDGE END

March 31, 2000

Published Date: 3rd Qtr. 2013

**S
D
D
O
T**

**POST SPACING ARRANGEMENT FOR
 W BEAM GUARDRAIL AT BRIDGE END**

PLATE NUMBER
 630.50

Sheet 1 of 1

**0001-271, 0001-272, 0001-291 & 000P-292 - GUARDRAIL REPAIR
 BON HOMME, CHARLES MIX, CLAY, HUTCHINSON, LAKE, LINCOLN, MINER,
 MINNEHAHA, MOODY, TURNER, UNION & YANKTON COUNTIES**

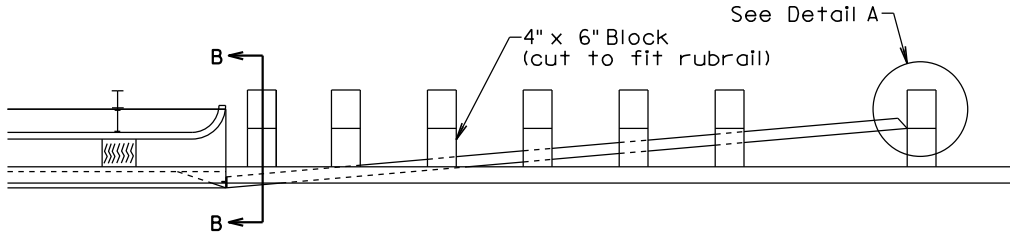

PLAN

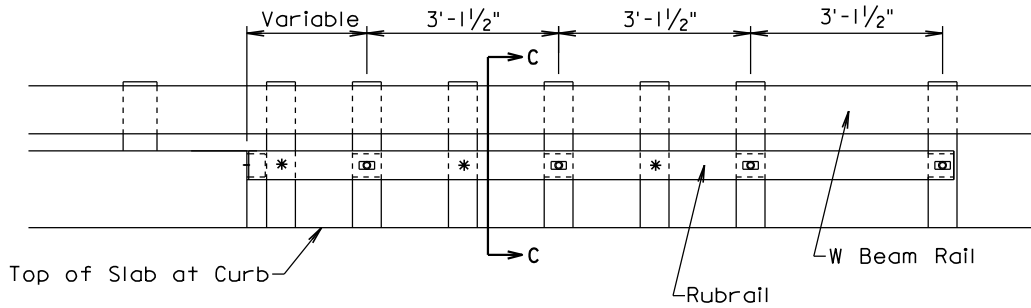

*Rubrail does not have to be attached to these posts.

ELEVATION

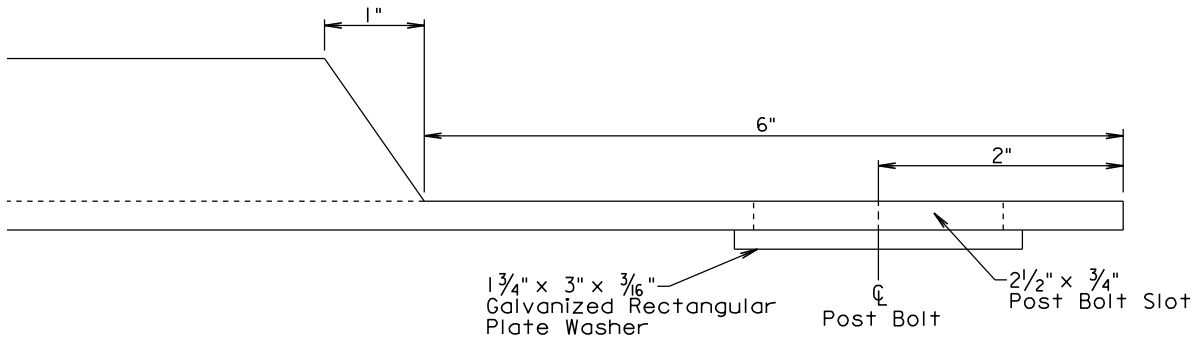

DETAIL A

(Post, Block, and Post Bolt not shown)

GENERAL NOTES:

The steel shall be in conformance with ASTM A 36 and shall be galvanized after fabrication in conformance with ASTM A 123. If pre-galvanized steel members are used, all cuts and welds shall be coated with an approved galvanizing paint.

Offset blocks shall be in conformance with section 630 of the Standard Specifications.

All hardware shall be in conformance with the requirements of AASHTO M 180.

March 31, 2000

| | | |
|-------------------|---|-------------------------------|
| SD DOT | RUBRAIL AT BRIDGE END (W BEAM RETROFIT AND CAST IN INSERT) | PLATE NUMBER 630.77 |
| | | Sheet 1 of 2 |

Published Date: 3rd Qtr. 2013

**0001-271, 0001-272, 0001-291 & 000P-292 - GUARDRAIL REPAIR
 BON HOMME, CHARLES MIX, CLAY, HUTCHINSON, LAKE, LINCOLN, MINER,
 MINNEHAHA, MOODY, TURNER, UNION & YANKTON COUNTIES**

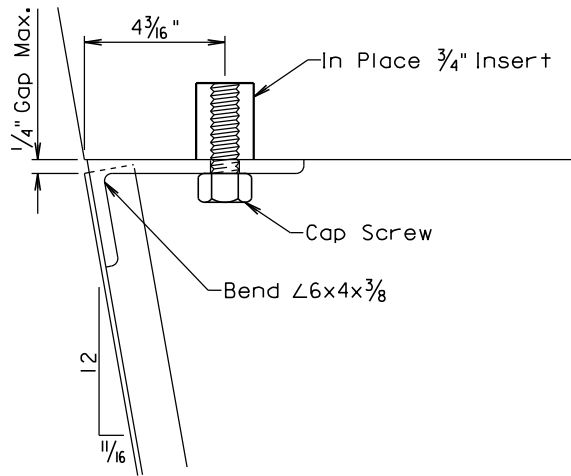

SECTION A-A

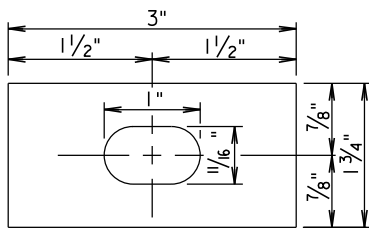

RECTANGULAR PLATE WASHER

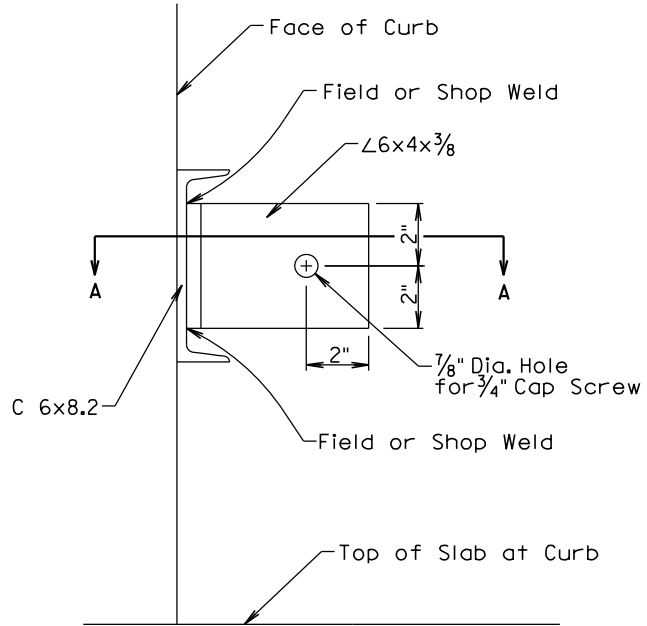

SECTION B-B

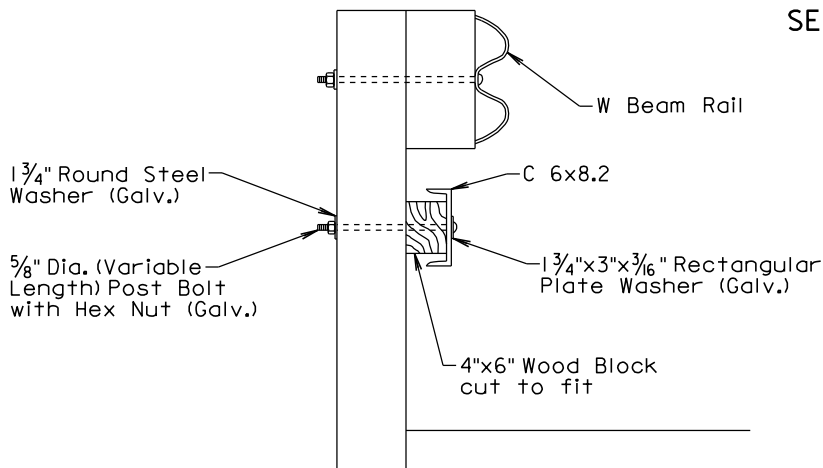

SECTION C-C

March 31, 2000

Published Date: 3rd Qtr. 2013

**S
D
D
O
T**

**RUBRAIL AT BRIDGE END
 (W BEAM RETROFIT AND CAST IN INSERT)**

PLATE NUMBER
 630.77

Sheet 2 of 2

**0001-271, 0001-272, 0001-291 & 000P-292 - GUARDRAIL REPAIR
 BON HOMME, CHARLES MIX, CLAY, HUTCHINSON, LAKE, LINCOLN, MINER,
 MINNEHAHA, MOODY, TURNER, UNION & YANKTON COUNTIES**

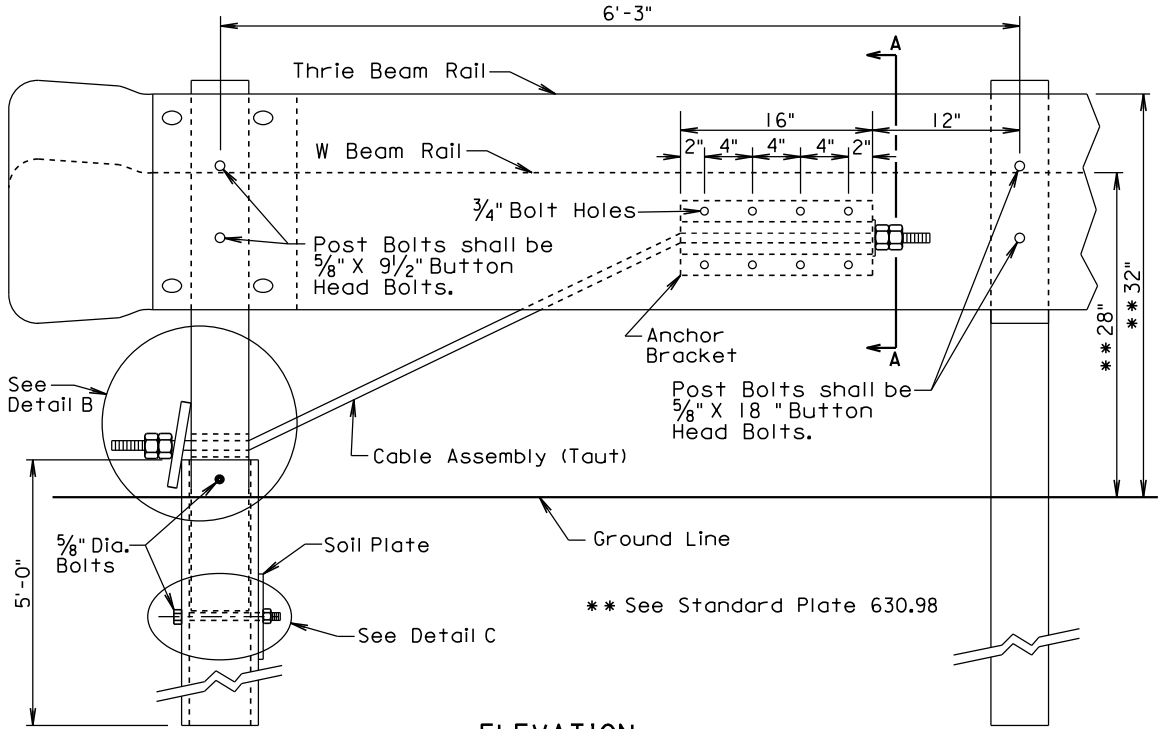
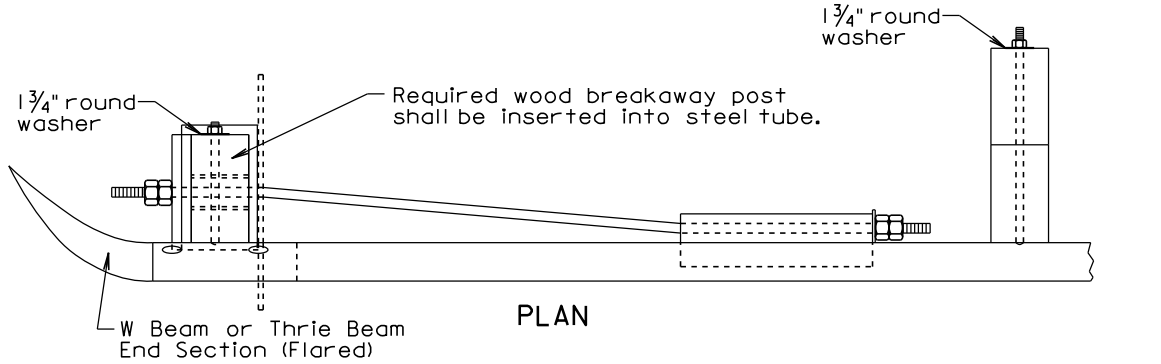

GENERAL NOTES:

- All hardware shall be galvanized in accordance with ASTM A153.
- The cable shall be 3/4", Type II, with Class A coating in conformance with AASHTO M30.
- The steel tube shall meet the requirements of ASTM Specification A500, Grade B, and shall be galvanized after fabrication in accordance with the requirements of AASHTO Specification M111.
- The anchor bracket, soil plate, and bearing plate shall be fabricated from steel that meets ASTM A36 Specifications. They shall be galvanized after fabrication in accordance with ASTM A123.
- Costs for constructing the beam guardrail trailing end terminal and furnishing the anchor bracket, cable assembly, steel tube, soil plate, bearing plate, pipe sleeve, wood breakaway post, and all hardware necessary to attach anchor bracket, cable assembly, steel tube, soil plate, bearing plate, pipe sleeve, and wood breakaway post shall be incidental to the contract unit price per each for "Beam Guardrail Trailing End Terminal".
- Costs for the thrie beam or W beam guardrail and the thrie beam or W beam end sections (Flared) shall be incidental to the contract unit price per foot for the respective "Thrie Beam Guardrail" or "W Beam Guardrail" bid items.

June 26, 2010

| | | |
|----------------------------------|---|-------------------------------|
| S D D O T | BEAM GUARDRAIL TRAILING END TERMINAL | PLATE NUMBER 630.80 |
| | | Sheet 1 of 2 |

Published Date: 3rd Qtr. 2013

**0001-271, 0001-272, 0001-291 & 000P-292 - GUARDRAIL REPAIR
 BON HOMME, CHARLES MIX, CLAY, HUTCHINSON, LAKE, LINCOLN, MINER,
 MINNEHAHA, MOODY, TURNER, UNION & YANKTON COUNTIES**

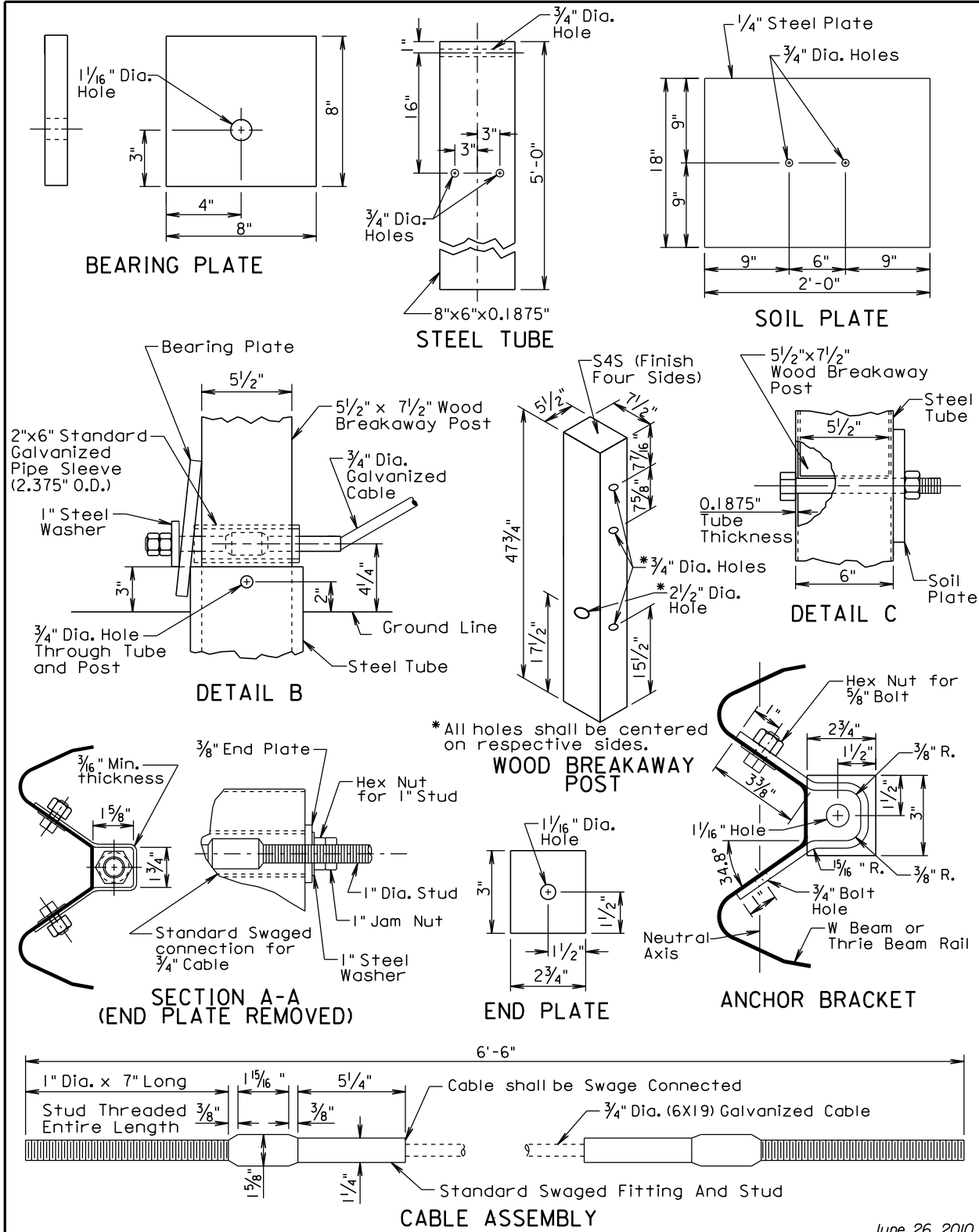

June 26, 2010

| | | |
|--|--|---------------------------------------|
| <p>SDDOT</p> <p>Published Date: 3rd Qtr. 2013</p> | <p>BEAM GUARDRAIL TRAILING END TERMINAL</p> | <p>PLATE NUMBER 630.80</p> |
| | | <p>Sheet 2 of 2</p> |

**0001-271, 0001-272, 0001-291 & 000P-292 - GUARDRAIL REPAIR
 BON HOMME, CHARLES MIX, CLAY, HUTCHINSON, LAKE, LINCOLN, MINER,
 MINNEHAHA, MOODY, TURNER, UNION & YANKTON COUNTIES**

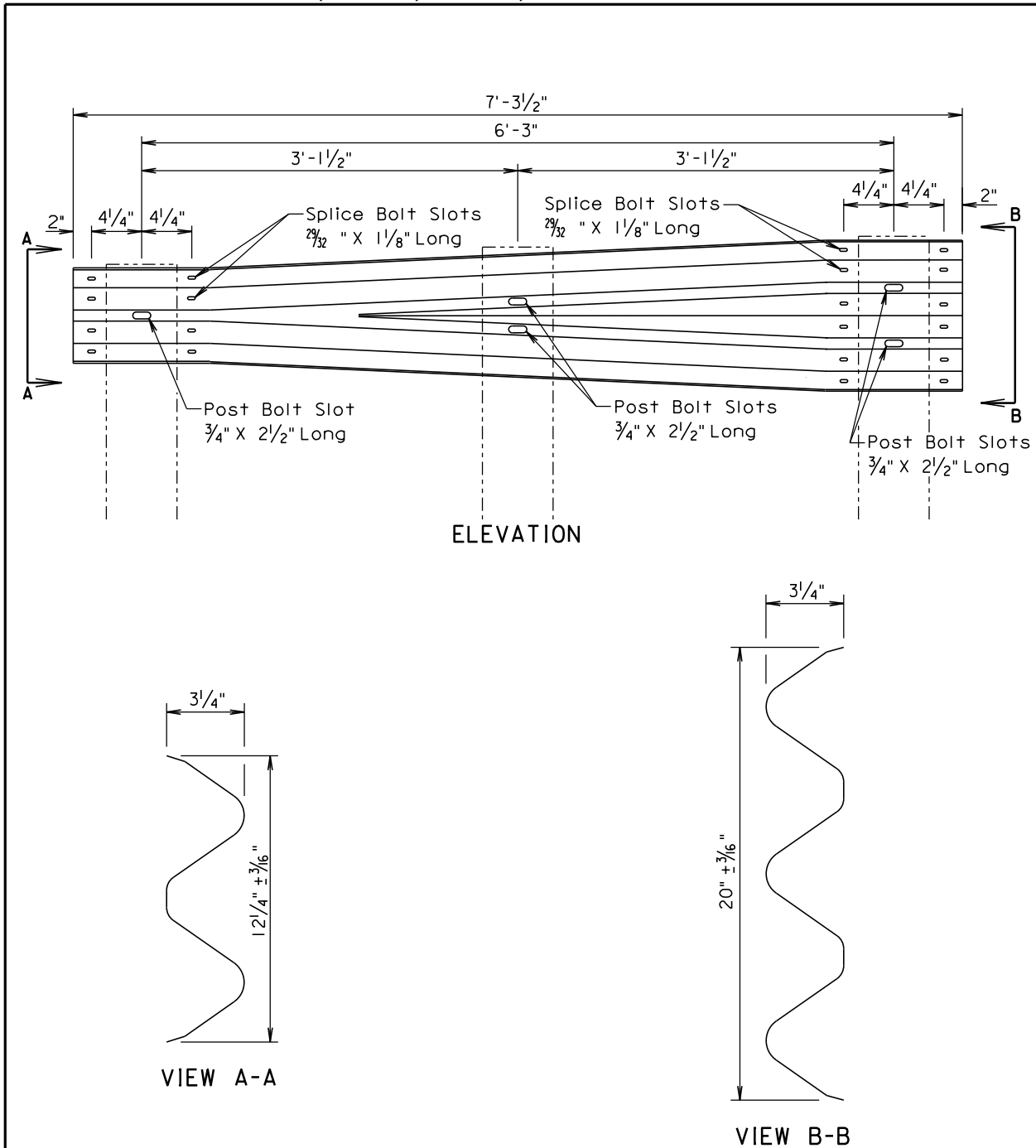

GENERAL NOTE:

All costs for constructing the W Beam to Thrie Beam Guardrail Transition including labor, equipment, and materials including two posts, two blocks, W beam to thrie beam transition section, and hardware shall be incidental to the contract unit price per each for "W Beam to Thrie Beam Guardrail Transition".

March 31, 2000

| | | | |
|--------------------------------------|----------------------------------|--|--|
| <i>Published Date: 3rd Qtr. 2013</i> | S D D O T | W BEAM TO THRIE BEAM GUARDRAIL TRANSITION SECTION | |
| | | PLATE NUMBER 630.82 Sheet 1 of 1 | |

**0001-271, 0001-272, 0001-291 & 000P-292 - GUARDRAIL REPAIR
 BON HOMME, CHARLES MIX, CLAY, HUTCHINSON, LAKE, LINCOLN, MINER,
 MINNEHAHA, MOODY, TURNER, UNION & YANKTON COUNTIES**

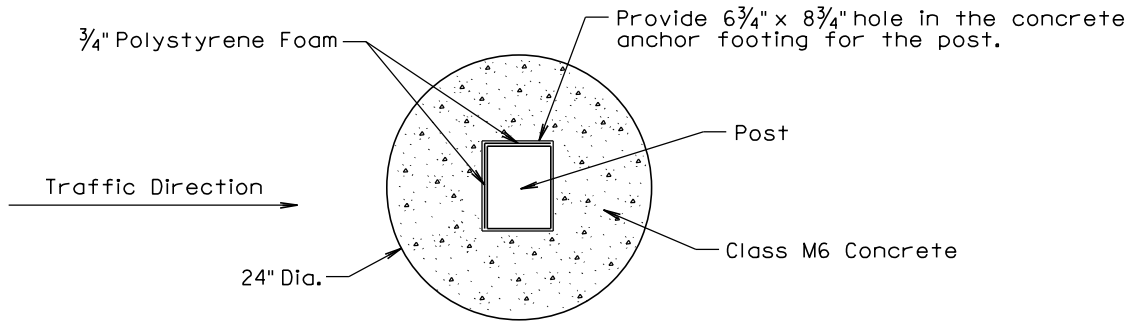

**PLAN
 (PREFERRED 24" DIA. ROUND
 CONCRETE ANCHOR FOOTING)**

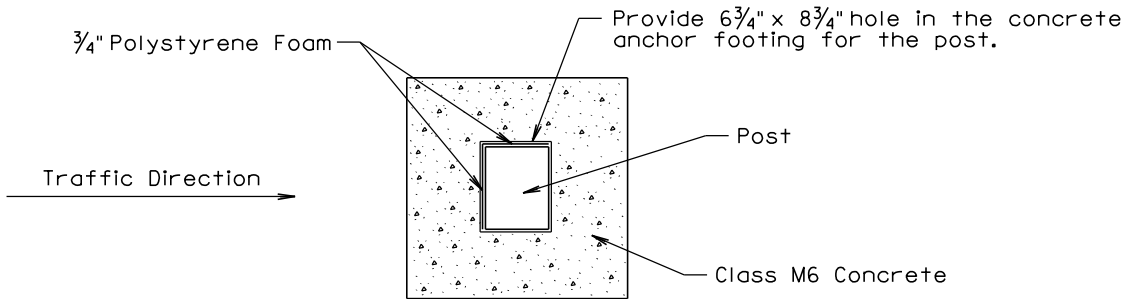

**PLAN
 (20" x 20" SQUARE
 CONCRETE ANCHOR FOOTING)**

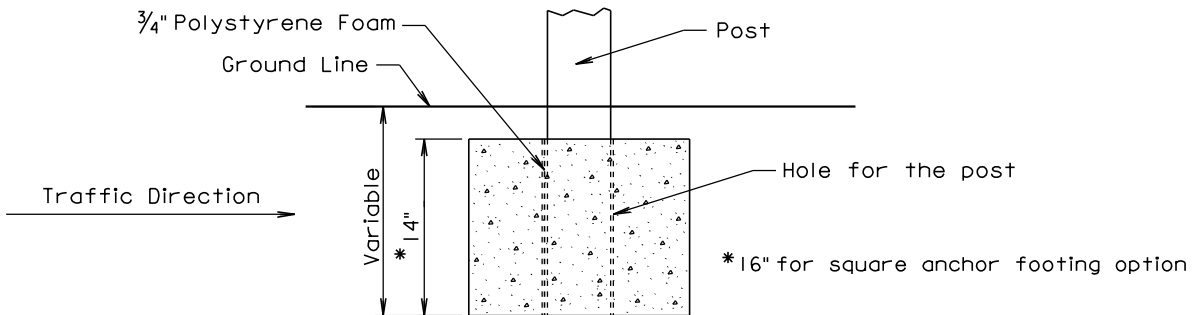

ELEVATION

GENERAL NOTES:

In areas where the required guardrail wood post depth is not obtainable, shorter posts may be used and shall be anchored in concrete in accordance with the details shown on this standard plate.

A 20" x 20" square concrete anchor footing may be used in lieu of the 24" diameter round anchor footing.

Forms for the concrete anchor footing hole is not required.

Concrete for the concrete anchor footing shall be Class M6.

Three quarter inch polystyrene foam shall be attached to two sides of the posts. See details above for placement position of the polystyrene foam.

There will be no separate payment for furnishing and installing the concrete anchor footing for short guardrail post. All costs for concrete anchor footings shall be incidental to the contract unit price per foot for the respective "Thrie Beam or W Beam Guardrail" bid item.

March 31, 2000

| | | |
|----------------------------------|---|-------------------------------|
| S D D O T | CONCRETE ANCHOR FOOTING FOR SHORT GUARDRAIL POST | PLATE NUMBER 630.84 |
| | | Sheet 1 of 1 |

Published Date: 3rd Qtr. 2013

**0001-271, 0001-272, 0001-291 & 000P-292 - GUARDRAIL REPAIR
 BON HOMME, CHARLES MIX, CLAY, HUTCHINSON, LAKE, LINCOLN, MINER,
 MINNEHAHA, MOODY, TURNER, UNION & YANKTON COUNTIES**

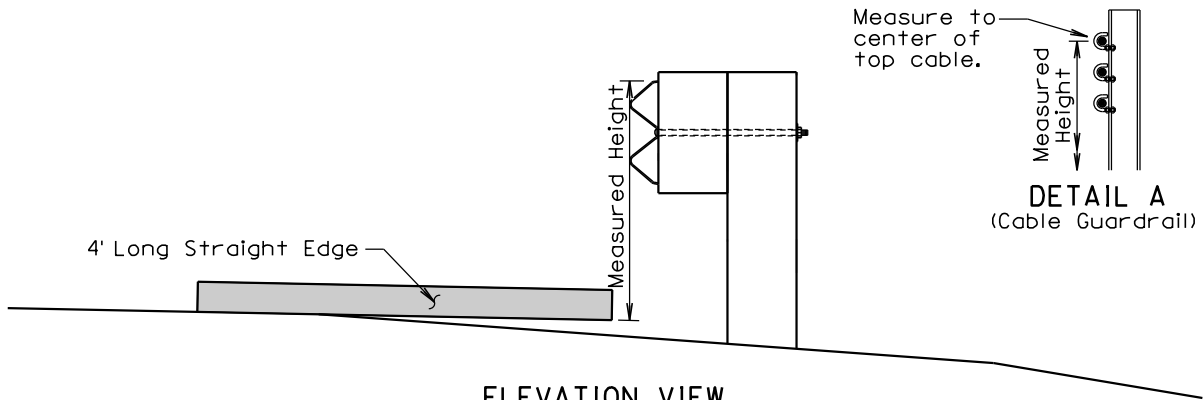

ELEVATION VIEW
 (Guardrail Adjacent to Differential Slopes)

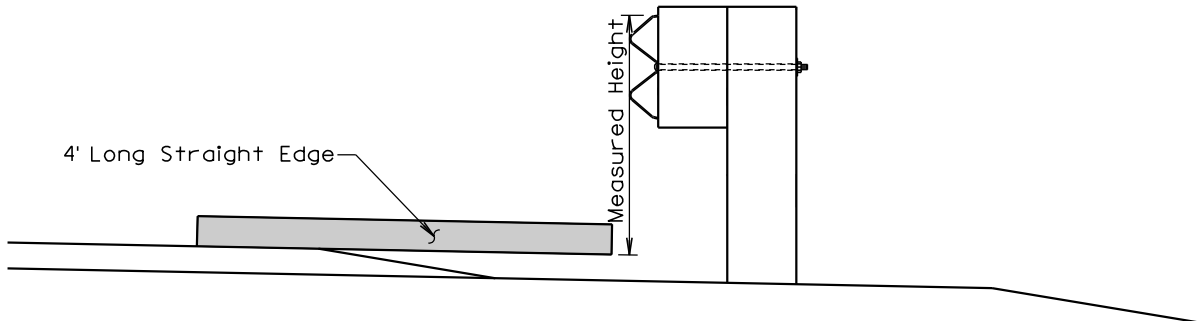

ELEVATION VIEW
 (Guardrail Adjacent to Differential Surfacing Elevations)

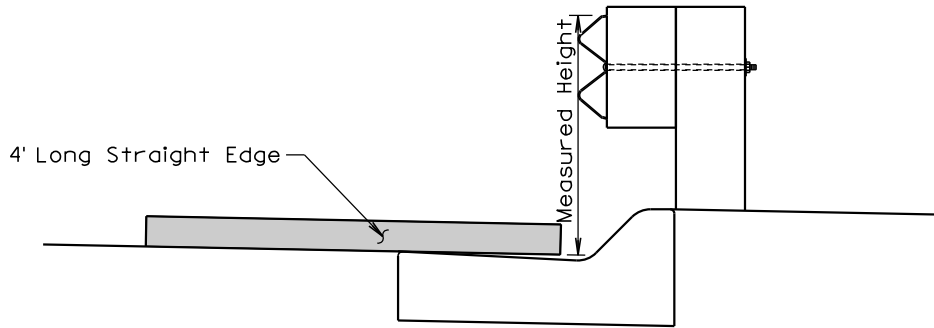

ELEVATION VIEW
 (Guardrail at Curb and Gutter)

GENERAL NOTES:

The W Beam guardrail shown is for illustrative purpose. The guardrail height for all types of guardrail systems shall be measured in accordance with this standard plate.

When measuring height of cable guardrail or cable barrier the height shall be measured to the center of the top cable. See Detail A.

June 26, 2010

| | | | |
|--------------------------------------|----------------------------------|-----------------------------------|-------------------------------|
| <i>Published Date: 3rd Qtr. 2013</i> | S D D O T | MEASURING GUARDRAIL HEIGHT | PLATE NUMBER 630.98 |
| | | | <i>Sheet 1 of 1</i> |

**000I-271, 000I-272, 000I-291 & 000P-292 - GUARDRAIL REPAIR
 BON HOMME, CHARLES MIX, CLAY, HUTCHINSON, LAKE, LINCOLN, MINER,
 MINNEHAHA, MOODY, TURNER, UNION & YANKTON COUNTIES**

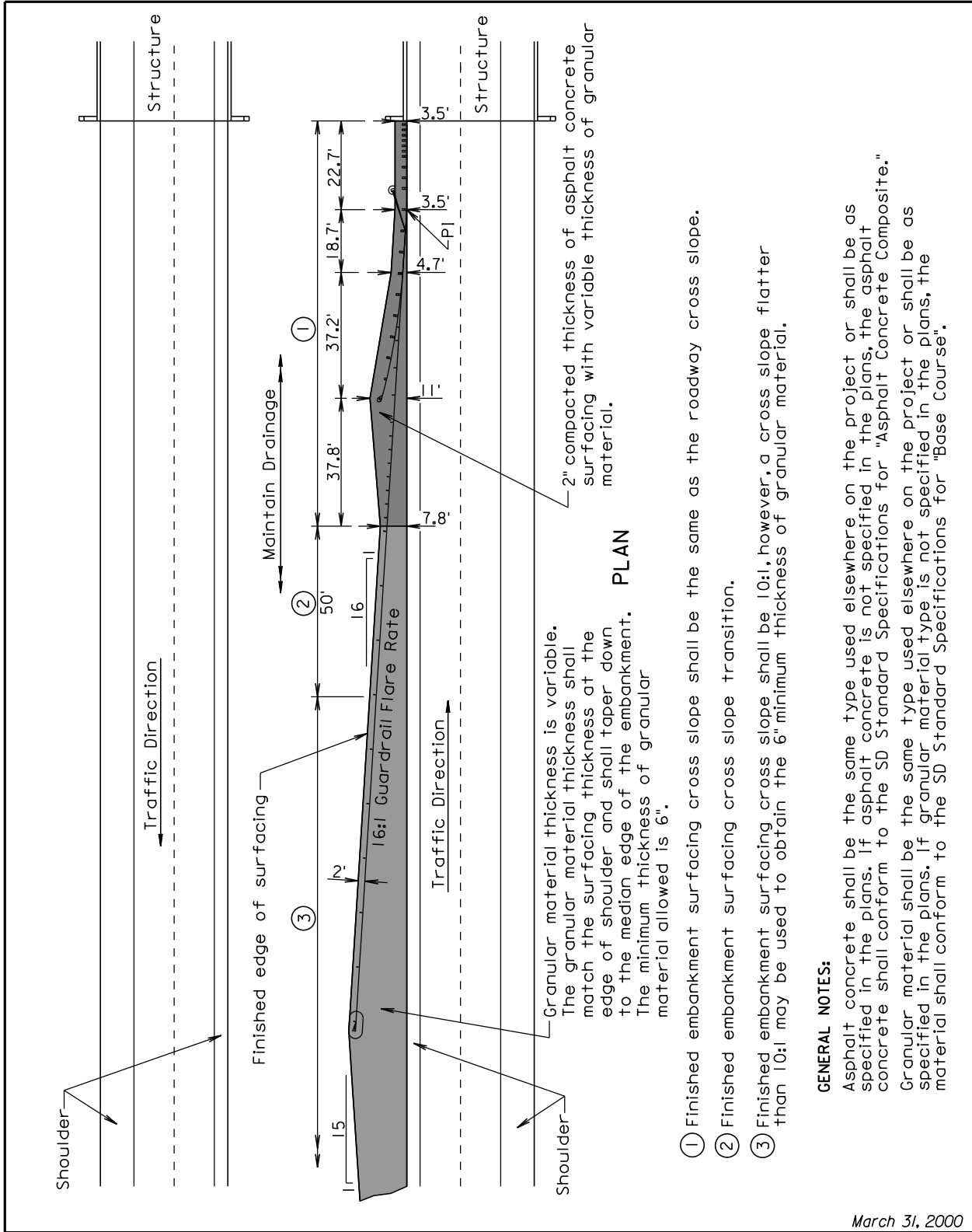

Granular material thickness is variable. The granular material thickness shall match the surfacing thickness at the edge of shoulder and shall taper down to the median edge of the embankment. The minimum thickness of granular material allowed is 6".

PLAN

- ① Finished embankment surfacing cross slope shall be the same as the roadway cross slope.
- ② Finished embankment surfacing cross slope transition.
- ③ Finished embankment surfacing cross slope shall be 10:1, however, a cross slope flatter than 10:1 may be used to obtain the 6" minimum thickness of granular material.

GENERAL NOTES:
 Asphalt concrete shall be the same type used elsewhere on the project or shall be as specified in the plans. If asphalt concrete is not specified in the plans, the asphalt concrete shall conform to the SD Standard Specifications for "Asphalt Concrete Composite."
 Granular material shall be the same type used elsewhere on the project or shall be as specified in the plans. If granular material type is not specified in the plans, the material shall conform to the SD Standard Specifications for "Base Course".



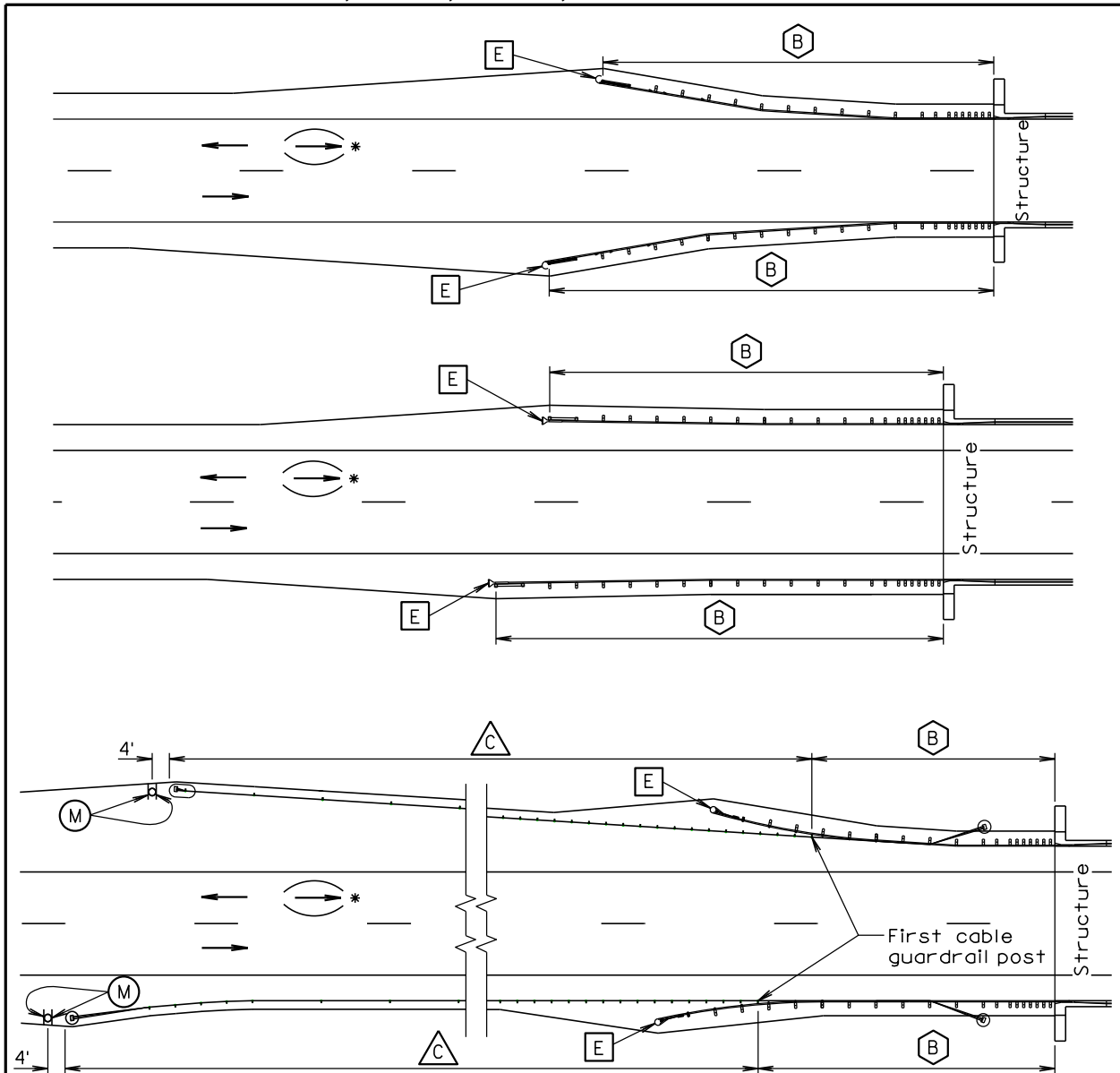

March 31, 2000

| | | | |
|-------------------------------|-------------------|---|-------------------------------|
| Published Date: 3rd Qtr. 2013 | SD DOT | EMBANKMENT AND SURFACING FOR TYPICAL MEDIAN PROTECTION | PLATE NUMBER 630.99 |
| | | | Sheet 1 of 1 |

**0001-271, 0001-272, 0001-291 & 000P-292 - GUARDRAIL REPAIR
 BON HOMME, CHARLES MIX, CLAY, HUTCHINSON, LAKE, LINCOLN, MINER,
 MINNEHAHA, MOODY, TURNER, UNION & YANKTON COUNTIES**



TYPICAL GUARDRAIL LAYOUTS

-  Steel Beam Guardrail Delineation
-  Guardrail Terminal End Object Marker
-  3 Cable Guardrail Delineation
-  Type 2 Object Marker

*For two-way traffic, install delineation at the opposite end of structure the same as shown. Back-to-back delineation is required for two-way traffic, single-sided delineation for one-way traffic.

June 26, 2011

Published Date: 3rd Qtr. 2013

**S
D
D
O
T**

DELINEATION OF GUARDRAIL AT BRIDGES

**PLATE NUMBER
632.40**

Sheet 1 of 4

**0001-271, 0001-272, 0001-291 & 000P-292 - GUARDRAIL REPAIR
 BON HOMME, CHARLES MIX, CLAY, HUTCHINSON, LAKE, LINCOLN, MINER,
 MINNEHAHA, MOODY, TURNER, UNION & YANKTON COUNTIES**

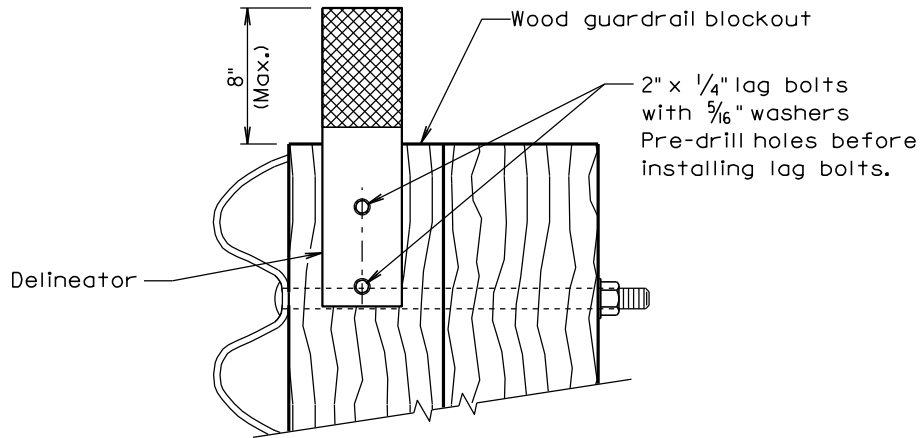

(B) STEEL BEAM GUARDRAIL DELINEATION

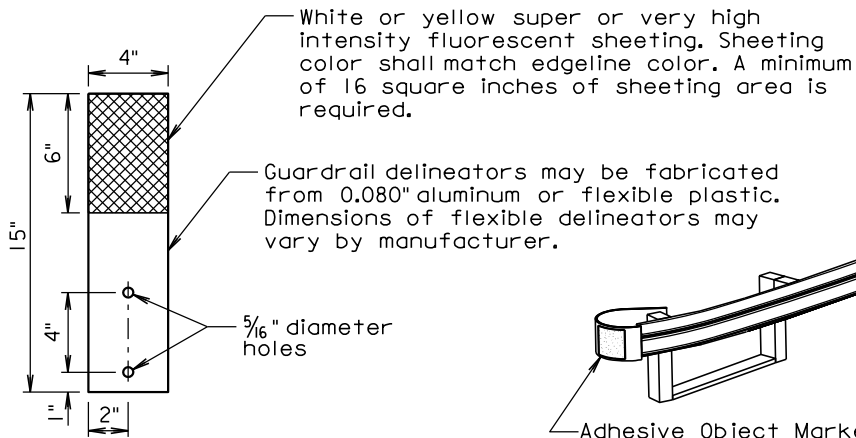

DELINEATOR
(For Steel Beam Guardrail)

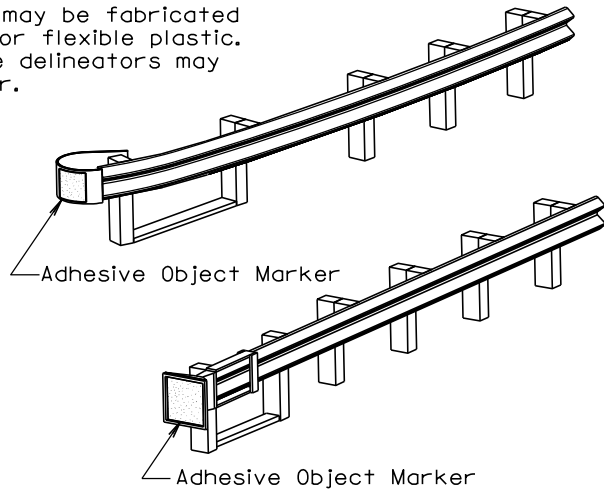

(E) GUARDRAIL TERMINAL END OBJECT MARKER

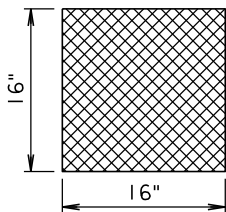

ADHESIVE OBJECT MARKER

Adhesive object marker dimensions may vary due to shape of terminal end. A minimum of 256 square inches of object marker sheetting area is required. The sheetting shall be fluorescent yellow super or very high intensity.

June 26, 2011

| | | | |
|--------------------------------------|----------------------------------|--|-------------------------------|
| <i>Published Date: 3rd Qtr. 2013</i> | S D D O T | DELINEATION OF GUARDRAIL AT BRIDGES | PLATE NUMBER 632.40 |
| | | | Sheet 2 of 4 |

**0001-271, 0001-272, 0001-291 & 000P-292 - GUARDRAIL REPAIR
 BON HOMME, CHARLES MIX, CLAY, HUTCHINSON, LAKE, LINCOLN, MINER,
 MINNEHAHA, MOODY, TURNER, UNION & YANKTON COUNTIES**

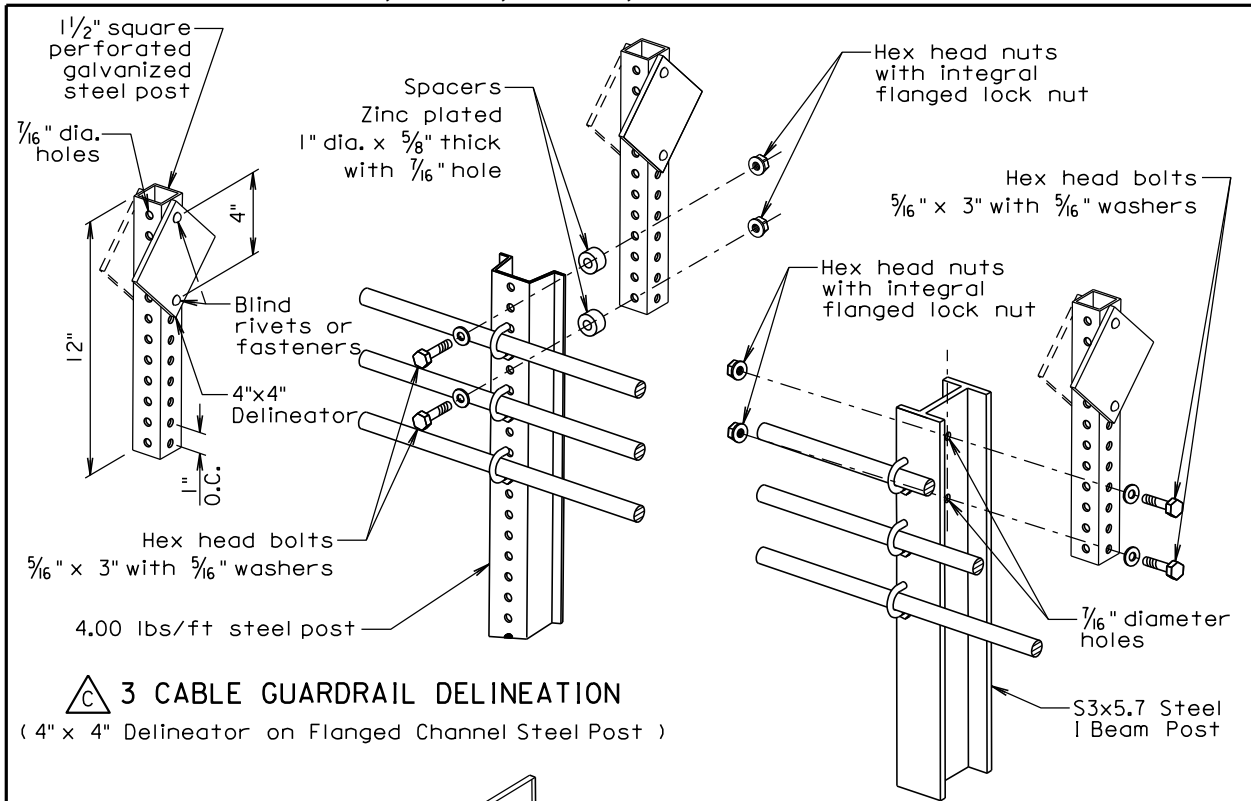

△ 3 CABLE GUARDRAIL DELINEATION
 (4" x 4" Delineator on Flanged Channel Steel Post)

△ 3 CABLE GUARDRAIL DELINEATION
 (4" x 4" Delineator on I Beam Steel Post)

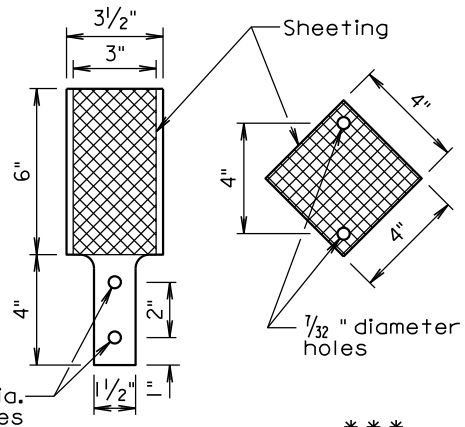
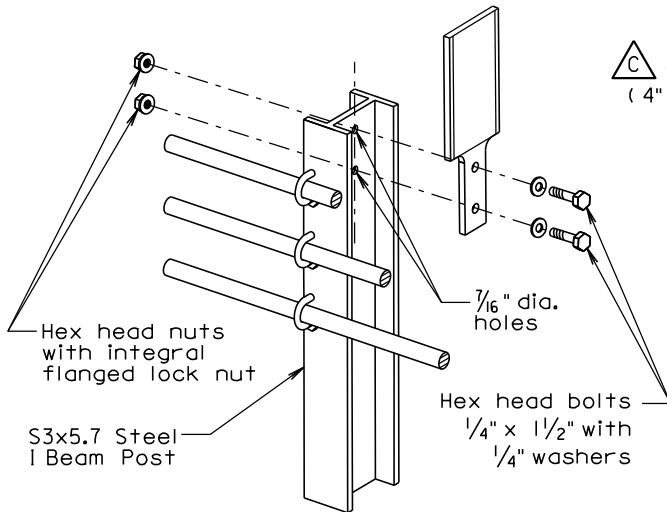

△ 3 CABLE GUARDRAIL DELINEATION**
 (Flexible 3" x 6" Delineator on I Beam Post)

DELINEATORS***
 (For 3 Cable Guardrail)

** Flexible delineators may be attached to post with manufacturer approved adhesive instead of bolts.
 *** Dimensions of flexible delineators may vary by manufacturer. A minimum of 16 square inches of sheeting area is required. The sheeting shall be white or yellow super or very high intensity fluorescent sheeting. The sheeting color shall match the edgeline color.

June 26, 2011

| | | | |
|--------------------------------------|----------------------------------|--|--------------------------------|
| <i>Published Date: 3rd Qtr. 2013</i> | S D D O T | DELINEATION OF GUARDRAIL AT BRIDGES | PLATE NUMBER 632.40 |
| | | | Sheet 3 of 4 |

**0001-271, 0001-272, 0001-291 & 000P-292 - GUARDRAIL REPAIR
 BON HOMME, CHARLES MIX, CLAY, HUTCHINSON, LAKE, LINCOLN, MINER,
 MINNEHAHA, MOODY, TURNER, UNION & YANKTON COUNTIES**

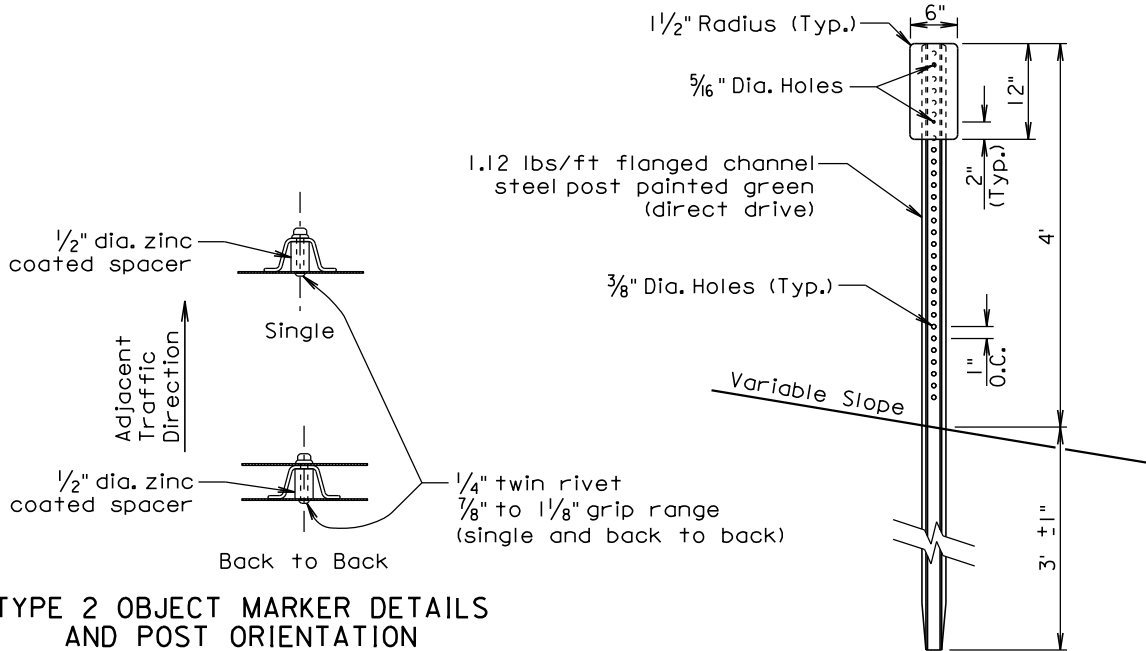

**TYPE 2 OBJECT MARKER DETAILS
 AND POST ORIENTATION**

**(M) TYPE 2 OBJECT MARKER
 (For Marking 3 Cable Guardrail Anchor)**

GENERAL NOTES:

The delineators shall be covered with a minimum of 16 square inches of reflective sheeting. The reflective sheeting shall be of either very high intensity or super high intensity material. For bridges along two-way roadways the sheeting shall be on both sides of the delineator and shall be white in color. For one-way roadways the sheeting will only be required on the side facing traffic and the color will be the same as the nearest pavement marking, yellow on the left side of the roadway and white on the right side.

The first delineator shall be attached to the post nearest the bridge with additional delineators spaced in advance of the bridge at approximately 50 foot intervals. At bridges with short lengths of guardrail, less than 200 feet, a minimum of 4 delineators shall be placed in addition to the yellow object marker. The spacing between the delineators shall be approximately one third of the length of the guardrail. This will provide for a shorter spacing. At bridges with longer lengths of guardrail, greater than 200 feet, including bridges that have cable guardrail transitioning into the steel beam guardrail, the delineators will be placed at a spacing of approximately 50 feet. Delineation shall extend throughout the length of the guardrail system.

All costs for furnishing and installing single or back to back guardrail delineation shall be included in the contract unit price per each for "Guardrail Delineator".

An adhesive object marker shall be placed on the end of the W beam guardrail end terminal. The adhesive object marker dimensions may vary due to the shape of the terminal end. A minimum of 256 square inches of object marker reflective sheeting area is required. The reflective sheeting shall be fluorescent yellow super or very high intensity. All costs for furnishing and installing the adhesive object marker shall be incidental to various contract items.

A type 2 object marker shall be placed adjacent to the 3 cable guardrail anchor at the location noted on sheet 1 of this standard plate. The type 2 object marker (6" x 12") shall have a fluorescent yellow very high or super high intensity reflective sheeting. All costs for furnishing and installing the type 2 object marker including the steel post, 6" x 12" reflective panel, and hardware shall be included in the contract unit price per each for "Type 2 Object Marker" for single-sided and "Type 2 Object Marker Back to Back" for back to back type 2 object markers.

June 26, 2011

| | | |
|----------------------------------|--|-------------------------------|
| S D D O T | DELINEATION OF GUARDRAIL AT BRIDGES | PLATE NUMBER 632.40 |
| | | Sheet 4 of 4 |

Published Date: 3rd Qtr. 2013