

STATE OF SOUTH DAKOTA	PROJECT	SHEET	TOTAL SHEETS
	044-292	1	13

Plotting Date: 03/11/2021

STATE OF SOUTH DAKOTA  
DEPARTMENT OF TRANSPORTATION  
PLANS FOR PROPOSED

**PROJECT 044-292**  
**SD HIGHWAY 44**  
**HUTCHINSON AND TURNER COUNTIES**  
**PIPE REPLACEMENT**  
**PCN I6AF**

INDEX OF SHEETS

- SHEET 1 GENERAL LAYOUT WITH INDEX
- SHEET 2 ESTIMATE OF QUANTITIES AND NOTES
- SHEETS 3 to 5 NOTES AND SIGN TABLE
- SHEET 6 PIPE TABLE
- SHEET 7 EMBANKMENT AND SURFACING SECTION
- SHEETS 8 to 13 STANDARD PLATES

Prepared by Joseph Sestak

PLOT SCALE - 1:100000

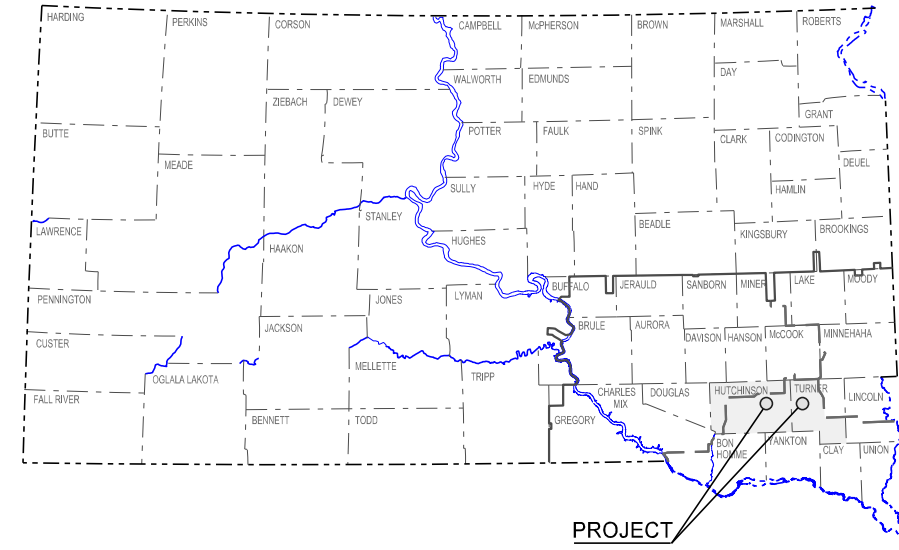

PLOTTED FROM - TRMLINT15

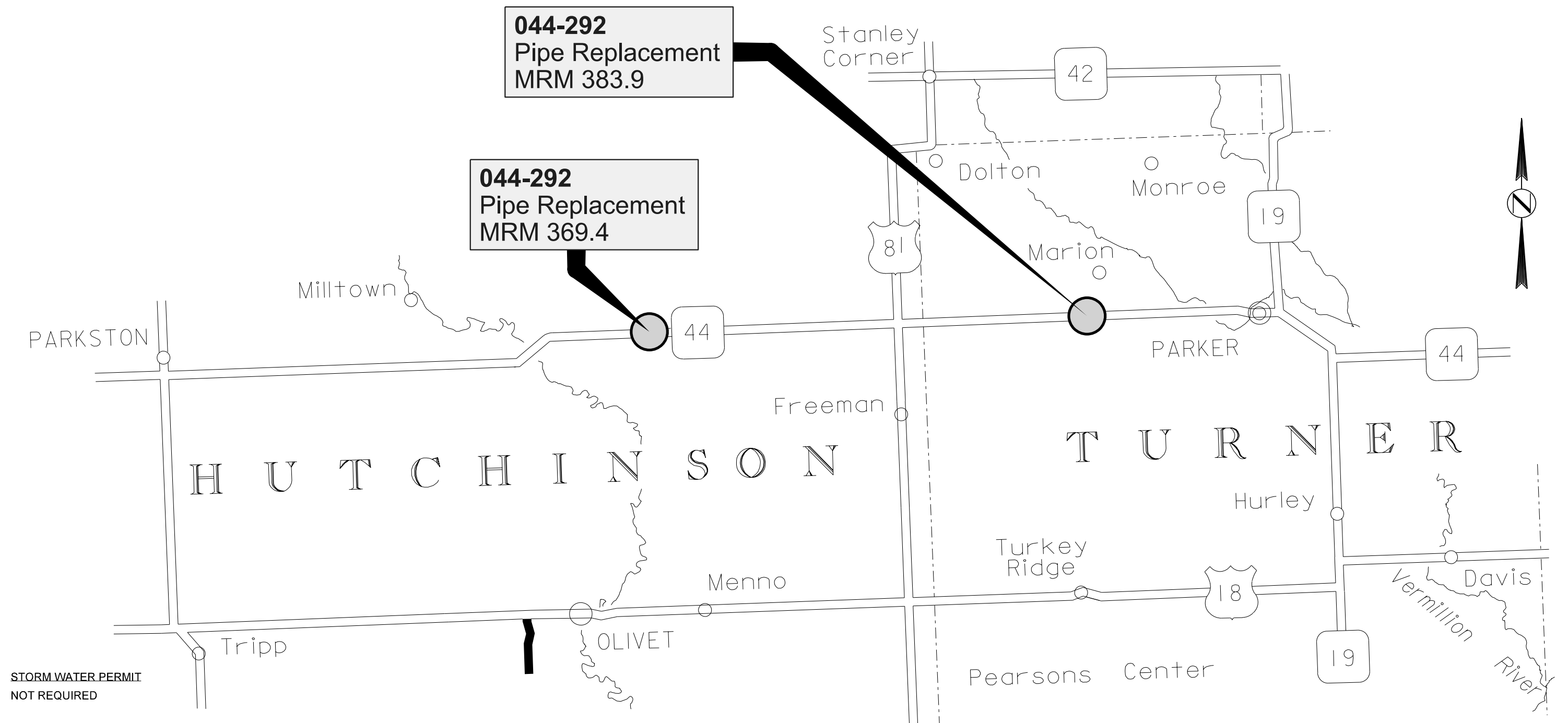

STORM WATER PERMIT  
NOT REQUIRED

FILE - ... \HUTCHINSON\PIPE REPAIR.DGN

**ESTIMATE OF QUANTITIES**

BID ITEM NUMBER	ITEM	QUANTITY	UNIT
009E0010	Mobilization	Lump Sum	LS
110E0500	Remove Pipe Culvert	240	Ft
110E0510	Remove Pipe End Section	6	Each
110E1010	Remove Asphalt Concrete Pavement	337.8	SqYd
120E0010	Unclassified Excavation	636	CuYd
230E0100	Remove and Replace Topsoil	Lump Sum	LS
260E1010	Base Course	542.0	Ton
320E1200	Asphalt Concrete Composite	90.3	Ton
421E0100	Pipe Culvert Undercut	93	CuYd
450E0142	24" RCP Class 2, Furnish	56	Ft
450E0150	24" RCP, Install	56	Ft
450E2016	24" RCP Flared End, Furnish	1	Each
450E2017	24" RCP Flared End, Install	1	Each
450E3042	42" RCP Arch Class 2, Furnish	120	Ft
450E3050	42" RCP Arch, Install	120	Ft
450E4516	42" RCP Arch Flared End, Furnish	4	Each
450E4517	42" RCP Arch Flared End, Install	4	Each
450E4769	24" CMP 16 Gauge, Furnish	50	Ft
450E4770	24" CMP, Install	50	Ft
450E5015	24" CMP Elbow, Furnish	2	Each
450E5016	24" CMP Elbow, Install	2	Each
450E5215	24" CMP Flared End, Furnish	1	Each
450E5216	24" CMP Flared End, Install	1	Each
450E8014	24" RCP to CMP Transition, Furnish	1	Each
450E8015	24" Pipe Transition, Install	1	Each
634E0010	Flagging	100.0	Hour
634E0110	Traffic Control Signs	544.0	SqFt
634E0120	Traffic Control, Miscellaneous	Lump Sum	LS
634E0600	4" Temporary Pavement Marking Tape Type I	288	Ft
634E0640	Temporary Pavement Marking	4,400	Ft
734E0010	Erosion Control	Lump Sum	LS

**SPECIFICATIONS**

Standard Specifications for Roads and Bridges, 2015 Edition and Required Provisions, Supplemental Specifications, and Special Provisions as included in the Proposal.

**SEQUENCE OF OPERATIONS**

1. Install traffic control measures.
2. Place perimeter erosion control measures.
3. Complete the culvert work.
4. Place final erosion control.
5. Remove the temporary traffic control measures.

Contractor requests to deviate from the sequence of operations will be submitted in writing to the Engineer for review. Approval of an alternate sequence of operations will only be allowed when the proposed changes meet with the Department's intent for traffic control and sequencing of the work. An alternate sequence will be submitted for review a minimum of one week prior to potential implementation.

**ENVIRONMENTAL COMMITMENTS**

The SDDOT is committed to protecting the environment and uses Environmental Commitments as a communication tool for the Engineer and Contractor to ensure that attention is given to avoid, minimize, and/or mitigate an environmental impact. Environmental commitments to various agencies and the public have been made to secure approval of this project. An agency with permitting authority can delay a project if identified environmental impacts have not been adequately addressed. Unless otherwise designated, the Contractor's primary contact regarding matters associated with these commitments will be the Project Engineer. During construction, the Project Engineer will verify that the Contractor has met Environmental Commitment requirements. These environmental commitments are not subject to change without prior written approval from the SDDOT Environmental Office.

Additional guidance on SDDOT's Environmental Commitments can be accessed through the Environmental Procedures Manual found at: <<https://dot.sd.gov/media/documents/EnvironmentalProceduresManual.pdf>>

For questions regarding change orders in the field that may have an effect on an Environmental Commitment, the Project Engineer will contact the Environmental Engineer at 605-773-3180 or 605-773-4336 to determine whether an environmental analysis and/or resource agency coordination is necessary.

Once construction is complete, the Project Engineer will review all environmental commitments for the project and document their completion.

**COMMITMENT B: FEDERALLY THREATENED, ENDANGERED, AND PROTECTED SPECIES**

**COMMITMENT B2: WHOOPING CRANE**

The Whooping Crane is a spring and fall migratory bird in South Dakota that is about 5 feet tall and typically stops on wetlands, rivers, and agricultural lands along their migration route. An adult Whooping Crane is white with a red crown and a long, dark, pointed bill. Immature Whooping Cranes are cinnamon brown. While in flight, their long necks are kept straight and their long dark legs trail behind. Adult Whooping Cranes' black wing tips are visible during flight.

**Action Taken/Required:**

Harassment or other measures to cause the Whooping Crane to leave the site is a violation of the Endangered Species Act. If a Whooping Crane is sighted roosting in the vicinity of the project, borrow pits, or staging areas associated with the project, cease construction activities in the affected area until the Whooping Crane departs and immediately contact the Project Engineer. The Project Engineer will contact the Environmental Office so that the sighting can be reported to USFWS.

**COMMITMENT B4: BALD EAGLE**

Bald eagles are known to occur in this area.

**Action Taken/Required:**

If a nest is observed within one mile of the project site, notify the Project Engineer immediately so that he/she can consult with the Environmental Office for an appropriate course of action.

**COMMITMENT C: WATER SOURCE**

The Contractor will not withdraw water with equipment previously used outside the State of South Dakota or previously used in aquatic invasive species (AIS) positive waters within South Dakota without prior approval from the SDDOT Environmental Office. To prevent and control the introduction and spread of invasive species into the project vicinity, all equipment shall be power washed with hot water (≥140 °F) and completely dried for a minimum of 7 days prior to subsequent use. South Dakota administrative rule 41:10:04:02 forbids the possession and transport of AIS; therefore, all attached dirt, mud, debris and vegetation must be removed and all compartments and tanks capable of holding standing water must be drained. This includes, but is not limited to, all equipment, pumps, lines, hoses and holding tanks.

**Action Taken/Required:**

The Contractor will obtain the necessary permits from the regulatory agencies such as the South Dakota Department of Environment and Natural Resources (DENR) and the United States Army Corps of Engineers (USACE) prior to water extraction activities.

Additional information and mapping of water sources impacted by Aquatic Invasive Species in South Dakota can be accessed at:  
< <http://sdleastwanted.com/maps/default.aspx> >

< [South Dakota Administrative Rule 41:10:04 Aquatic Invasive Species: https://sdlegislature.gov/rules/DisplayRule.aspx?Rule=41:10:04](https://sdlegislature.gov/rules/DisplayRule.aspx?Rule=41:10:04) >

**COMMITMENT E: STORM WATER**

Construction activities constitute less than 1 acre of disturbance.

**Action Taken/Required:**

At a minimum and regardless of project size, appropriate erosion and sediment control measures must be installed to control the discharge of pollutants from the construction site.

**COMMITMENT H: WASTE DISPOSAL SITE**

The Contractor will furnish a site(s) for the disposal of construction and/or demolition debris generated by this project.

**Action Taken/Required:**

Construction and/or demolition debris may not be disposed of within the Public ROW.

The waste disposal site(s) will be managed and reclaimed in accordance with the following from the General Permit for Construction/Demolition Debris Disposal Under the South Dakota Waste Management Program issued by the Department of Environment and Natural Resources.

The waste disposal site(s) will not be located in a wetland, within 200 feet of surface water, or in an area that adversely affects wildlife, recreation, aesthetic value of an area, or any threatened or endangered species, as approved by the Environmental Office and the Project Engineer.

If the waste disposal site(s) is located such that it is within view of any ROW, the following additional requirements will apply:

1. Construction and/or demolition debris consisting of concrete, asphalt concrete, or other similar materials will be buried in a trench separate from wood debris. The final cover over the construction and/or demolition debris will consist of a minimum of 1 foot of soil capable of supporting vegetation. Waste disposal sites provided outside of the Public ROW will be seeded in accordance with Natural Resources Conservation Service recommendations. The seeding recommendations may be obtained through the appropriate County NRCS Office. The Contractor will control the access to waste disposal sites not within the Public ROW with fences, gates, and placement of a sign or signs at the entrance to the site stating, "No Dumping Allowed".

2. Concrete and asphalt concrete debris may be stockpiled within view of the ROW for a period not to exceed the duration of the project. Prior to project completion, the waste shall be removed from view of the ROW or buried, and the waste disposal site reclaimed as noted above.

The above requirements will not apply to waste disposal sites that are covered by an individual solid waste permit as specified in SDCL 34A-6-58, SDCL 34A-6-1.13, and ARSD 74:27:10:06.

Failure to comply with the requirements stated above may result in civil penalties in accordance with South Dakota Solid Waste Law, SDCL 34A-6-1.31.

All costs associated with furnishing waste disposal site(s), disposing of waste, maintaining control of access (fence, gates, and signs), and reclamation of the waste disposal site(s) will be incidental to the various contract items.

**COMMITMENT I: HISTORIC PRESERVATION OFFICE CLEARANCES**

The SDDOT has obtained concurrence with the State Historic Preservation Office (SHPO or THPO) for all work included within the project limits and all department designated sources and designated option material sources, stockpile sites, storage areas, and waste sites provided within the plans.

**Action Taken/Required:**

All earth disturbing activities not designated within the plans require a cultural resource review prior to scheduling the pre-construction meeting. This work includes but is not limited to: Contractor furnished material sources, material processing sites, stockpile sites, storage areas, plant sites, and waste areas.

The Contractor will arrange and pay for a record search and when necessary, a cultural resource survey. The Contractor has the option to contact the state Archaeological Research Center (ARC) at 605-394-1936 or another qualified archaeologist, to obtain either a records search or a cultural resources survey. A record search might be sufficient for review if the site was previously surveyed; however, a cultural resources survey may need to be conducted by a qualified archaeologist.

The Contractor will provide ARC with the following: a topographical map or aerial view in which the site is clearly outlined, site dimensions, project number, and PCN. If applicable, provide evidence that the site has been previously disturbed by farming, mining, or construction activities with a landowner statement that artifacts have not been found on the site.

The Contractor will submit the cultural resources survey report to SDDOT Environmental Office, 700 East Broadway Avenue, Pierre, SD 57501-2586. SDDOT will submit the information to the appropriate SHPO/THPO. Allow **30 Days** from the date this information is submitted to the Environmental Engineer for SHPO/THPO review.

In the event of an inadvertent discovery of human remains, funerary objects, or if evidence of cultural resources is identified during project construction activities, then such activities within 100 feet of the inadvertent discovery will immediately cease and the Project Engineer will be immediately notified. The Project Engineer will contact the SDDOT Environmental Office, who will contact the appropriate SHPO/THPO within 48 hours of the discovery to determine an appropriate course of action.

SHPO/THPO review does not relieve the Contractor of the responsibility for obtaining any additional permits and clearances for Contractor furnished material sources, material processing sites, stockpile sites, storage areas, plant sites, and waste areas that affect wetlands, threatened and endangered species, or waterways. The Contractor will not utilize a site known or suspected of having contaminated soil or water. The Contractor will provide the required permits and clearances to the Project Engineer at the preconstruction meeting.

### **EXCAVATION FOR SHALLOW PIPE CULVERT REMOVAL**

The Contractor will be responsible for the maintenance of drainage between the phases of construction for the culvert replacement ½ roadway width at a time.

Unclassified Excavation is required for removal of shallow pipes.

After the existing pipes have been removed, the new pipe culvert will be undercut and the undercut backfilled according to the notes for Pipe Culvert Undercut.

The remainder of the pipe culvert excavation will be backfilled with soils taken from the pipe removal excavation or other suitable material as approved by the Engineer. The backfill will be benched into 2:1 excavation slope. Compaction of the backfill material be to the satisfaction of the Engineer. After the new pipe has been backfilled to the top of the subgrade, a 12" depth of base course and 5" depth (2-2.5" lifts) of asphalt concrete composite will be placed as a patch matching the existing asphalt concrete.

All work necessary to excavate and backfill the shallow pipes including labor, equipment, and incidentals will be incidental to the contract unit price per cubic yard for Unclassified Excavation. Payment for shallow pipe excavation will be based only on plans quantity and measurement of these excavation quantities during construction will not be performed.

The cost for asphalt composite installed over the pipe replacement will be paid for at the contract unit price per ton for Asphalt Concrete Composite.

Base Course installed for the undercut backfill, select fill and surfacing over the pipe replacement will be paid for at the contract unit price per ton for Base Course. Compaction will be to the satisfaction of the Engineer.

Pipe flowline for the new pipe end section will match that of existing pipe culvert. This may require that ditches be excavated in each direction from the pipe ends to maintain proper water flow through the pipe. Material from the ditch cleanout may be placed on the inslopes at the ditch cleanout locations or spread on the backslopes at some locations as directed by the Engineer.

Cleaning of existing ditches and disposal of soil will be incidental to the contract unit prices for the various items.

The quantities computed for excavation of the shallow pipe are based on the limits shown in the Layout of Embankment and Surfacing at Shallow Culverts Being Replaced.

The in place base course material will be incorporated into the Unclassified Excavation material and is included in the plans quantity.

Additional quantities will be included for payment only in the event that work sites other than those shown on the plans are added to the contract.

### **PIPE CULVERT UNDERCUT**

Pipe culvert undercut will be required for this project. The culvert will be bedded in accordance with Section 450.3 F.2, Class B Bedding with the following exception. The undercut area will extend two feet from the outermost diameter on both sides of the pipe with the back of the excavated area being benched into 2:1 excavation slope to the top of the roadway surface. Select fill material for Class B Bedding will conform to the gradation requirements of Base Course in Section 882. Compaction will be to the satisfaction of the Engineer. All other requirements of section 421 will apply.

Pipe Culvert Undercut will be paid for at the contract unit price per cubic yard for Pipe Culvert Undercut.

### **REMOVE AND REPLACE TOPSOIL**

Prior to starting construction operations, a sufficient volume of topsoil will be removed from the construction limits to cover the disturbed areas to the required thickness as indicated in these plans.

Following completion of grading operations, topsoil will be spread evenly over the disturbed areas. The thickness will be approximately 4 inches.

Removal and replacement of topsoil will not be measured for payment but will be included in the contract lump sum price for Remove and Replace Topsoil.

### **REPLACE MAINLINE CULVERTS**

The Contractor is encouraged to thoroughly investigate the culvert replacement sites prior to bidding.

Hauling of embankment material on established traveled roadways will be limited to trucks or small scrapers hauling legal loads and which do not cause damage to the roadway, as approved by the Engineer. Hauling of material in the roadway ditches will not be allowed.

The Contractor will be responsible for restoration of any areas disturbed outside the limits of the work area.

### **PLACING PIPE CULVERTS**

The Contractor will be responsible to reference the existing pipe culvert inlet and outlet elevations prior to removal of the pipe culverts. New pipe culvert ends will match the inlet and outlet elevations prior to construction to maintain drainage.

### **REMOVE ASPHALT CONCRETE**

The removal length listed in the plans is centered on the pipe culvert unless otherwise marked by the Engineer. The removal area will be sawed full depth.

All costs for the removal of asphalt concrete, sawing the removal area full depth and disposing of the material per the notes included in the plans are included in the contract unit price per square yard for Remove Asphalt Concrete Pavement.

### **DITCH CLEANOUT**

Ditch cleanout is required at all locations as directed by the Engineer. There will be no specific contract item for ditch cleanout. Ditch cleanout will be incidental to the various contract items.

Ditch cleanout will extend from the end of the culvert to within 1 foot of the Right-of-Way (ROW) Line. The bottom of the ditch cleanout will be a minimum of 10 feet wide and the side slopes on the channel will be 20:1 or flatter. For those locations where there is no channel from the inlet/outlet of the culvert to the ROW Line ditch cleanout will be completed such that there is a flat area of 100 Square Feet created at the inlet/outlet and the sides slopes around the flat area will be 20:1 or flatter.

Material from the ditch cleanout may be placed on the inslopes at the ditch cleanout locations, used as Unclassified Excavation or topsoil, or spread on the backslopes at some locations as directed by the Engineer.

Cleaning of existing ditches and disposal of soil will be incidental to the various bid items.

### **UTILITIES**

The Contractor will contact the involved utility companies through South Dakota One Call (1-800-781-7474) prior to starting work. It will be the responsibility of the Contractor to coordinate work with the utility owners to avoid damage to existing facilities.

Utilities are not planned to be affected on this project. If utilities are identified near the improvement area through the SD One Call Process as required by South Dakota Codified Law 49-7A and Administrative Rule Article 20:25, the Contractor will contact the Engineer to determine modifications that will be necessary to avoid utility impacts.

### **GPS COORDINATES**

The approximate GPS coordinates of the work locations have been included in the plans to help verify the work locations. The coordinates are not to be used for survey control or locates without verification by the Contractor. In the event that the GPS coordinates do not match the Mileage Reference Marker indicated the Contractor will notify the Engineer for verification of the work location.

### **REMOVE AND RESET TYPE 2 OBJECT MARKERS**

The Contractor will be required to remove prior to the work and reset after the work the Type 2 Object Markers delineating the pipe ends. Cost for this work will be incidental to the contract unit prices for the various items.

### **REMOVE PIPE CULVERT**

The pipe culvert removed will become the property of the Contractor for disposal.

**EROSION CONTROL**

The estimated area requiring erosion control is 15000 square feet. All costs for the erosion control work for furnishing, placing, and maintaining erosion control including equipment, labor, seeding, and mulching will be incidental to the contract lump sum price for "Erosion Control".

The limits of erosion control work will be determined by the Engineer during construction.

**MULCHING (GRASS HAY OR STRAW)**

If the Contractor uses a no-till drill, mulch may be applied prior to seeding and the mulch can then be punched into the soil by the no-till drill. If the Contractor uses this process, the no-till drill seeding will be completed immediately following the mulch application and the mulch will be punched into the soil at a 3-inch depth.

**PERMANENT SEEDING**

The areas to be seeded consist of all newly graded areas within the project limits except those covered by riprap.

Type G Permanent Seed Mixture will consist of the following:

Grass Species	Variety	Pure Live Seed (PLS) (Pounds/Acre)
Western Wheatgrass	Arriba, Flintlock, Rodan, Rosana, Walsh	7
Switchgrass	Dacotah, Forestburg, Nebraska 28, Pathfinder, Summer, Sunburst, Trailblazer	3
Indiangrass	Holt, Tomahawk, Chief, Nebraska 54	3
Big Bluestem	Bison, Bonilla, Champ, Sunnyview, Rountree, Bonanza	3
Oats or Spring Wheat: April through May; Winter Wheat: August through November		10
Total:		26

**TEMPORARY PAVEMENT MARKING**

Temporary pavement marking for stop bars will consist of 4" temporary pavement marking tape type I. Placement of each 24" white stop bar will be accomplished by placing six pieces of 4" x 12' tape adjacent to one another. Each workspace requires two stop bars which is an equivalent of approximately 144' of 4" tape (2 workspaces at 144' = 288'). Temporary pavement marking on centerline will consist of temporary flexible vertical markers (tabs) or temporary raised pavement markers and will be used as depicted on standard plate 634.25 when the stop condition must remain in place during nighttime hours, 9:00 pm to 6:00 am (Estimate 2 workspaces remaining during nighttime hours x 2,200' per workspace = 4400').

**MYCORRHIZAL INOCULUM**

Mycorrhizal inoculum will consist of mycorrhizal fungi spores and mycorrhizal fungi-infected root fragments in a solid carrier. The carrier may include organic materials, calcinated clay, or other materials consistent with application and good plant growth. The supplier will provide certification of the fungal species claimed and the live propagule count. The inoculum will include the following fungal species:

- 25% *Glomus intraradices*
- 25% *Glomus aggregatum or deserticola*
- 25% *Glomus mosseae*
- 25% *Glomus etunicatum*

All seed will be inoculated by the seed supplier with a minimum of 100,000 live propagules of mycorrhizal fungi per acre. All costs of inoculating the seed will be incidental to the contract unit price per pound for the corresponding permanent seed mixture.

The mycorrhizal inoculum will be as shown below or an approved equal:

Product	Manufacturer
MycosApply	Mycorrhizal Applications, Inc. Grants Pass, OR Phone: 1-866-476-7800 www.mycorrhizae.com
AM 120 Multi Species Blend	Reforestation Technologies Int. Gilroy, CA Phone: 1-800-784-4769 www.reforest.com

**FLAGGING**

Operations will be conducted so that the traveling public will not have to wait longer than 15 minutes at the flagger station.

It is required that the flaggers be able to communicate with one another. If an emergency vehicle needs to pass through the project, the Contractor will be required to expedite traffic movement. All costs associated with this will be incidental to the contract unit price per hour for "Flagging".

**GENERAL MAINTENANCE OF TRAFFIC**

Asphalt concrete sawing and surfacing may be completed with the lane closure with flaggers provided or with the lane closure using stop signs.

Sufficient traffic control devices have been included in these plans to sign two workspaces for the lane closure using stop signs. Two pipe locations with the lane closures using stop signs may be worked on simultaneously.

Road Work Ahead, Bump with advisory speed plate, and Loose Gravel sign will be used for each direction at each location.

Asphalt concrete composite placement for each site will begin within 30 calendar days after the lane closure using stop signs is set up for each site.

**GENERAL TRAFFIC CONTROL**

Existing guide, route, informational logo, regulatory, and warning signs will be temporarily reset and maintained during construction. Removing, relocating, covering, salvaging, and resetting of existing traffic control devices, including delineation, will be the responsibility of the Contractor. Cost for this work will be incidental to the contract unit prices for the various items unless otherwise specified in the plans. Any delineators and signs damaged or lost will be replaced by the Contractor at no cost to the State.

All temporary traffic control sign locations will be set in the field by the Contractor and verified by the Engineer prior to installation.

If there is a discrepancy between the traffic control plans, standard plates, and the MUTCD, whichever is more stringent will be used, as determined by the Engineer.

Unless otherwise stated in these plans, work will not be allowed during hours of darkness.

Traffic Control Signs, as shown in the Estimate of Quantities, are estimates. Contractor's operation may require adjustments in quantities, either more or less. Payment will be for those signs actually ordered by the Engineer and used.

Fixed location signing placed more than 4 calendar days prior to the start of construction will be covered or laid down until the time of construction. The covers must be approved by the Engineer prior to installation. The cost of materials, labor, and equipment necessary to complete this work will be incidental to other contract items. No separate payment will be made.

All fixed location signs, sign posts, and breakaway bases will be removed within 7 calendar days following pavement marking.

All haul trucks will be equipped with an additional flashing amber light that is visible from the backside of the haul truck. The costs for the flashing amber lights will be incidental to the various related contract items.

**ITEMIZED LIST FOR TRAFFIC CONTROL SIGNS**

SIGN CODE	SIGN DESCRIPTION	CONVENTIONAL ROAD			
		NUMBER	SIGN SIZE	SQFT PER SIGN	SQFT
R1-1	STOP	4	30"	5.2	20.8
W1-3	REVERSE TURN (L or R)	2	48" x 48"	16.0	32.0
W3-1	STOP AHEAD (symbol)	4	48" x 48"	16.0	64.0
W8-1	BUMP	4	48" x 48"	16.0	64.0
W8-7	LOOSE GRAVEL	4	48" x 48"	16.0	64.0
W13-1P	ADVISORY SPEED (plaque)	4	30" x 30"	6.3	25.2
W20-1	ROAD WORK AHEAD	4	48" x 48"	16.0	64.0
W20-4	ONE LANE ROAD AHEAD	4	48" x 48"	16.0	64.0
W20-7	FLAGGER (symbol)	4	48" x 48"	16.0	64.0
W21-5	SHOULDER WORK	4	48" x 48"	16.0	64.0
G20-2	END ROAD WORK	4	36" x 18"	4.5	18.0
<b>CONVENTIONAL ROAD TRAFFIC CONTROL SIGNS SQFT</b>					<b>544.0</b>

### TABLE OF PIPE REPLACEMENT

HIGHWAY	MRM			SIZE AND TYPE	REMOVE PIPE CULVERT (FT)	REMOVE PIPE END SECTION (EACH)	24" RCP CLASS 2 FURNISH AND INSTALL (FT)	24" RCP FLARED END FURNISH AND INSTALL (EACH)	42" RCP ARCH CLASS 2 FURNISH AND INSTALL (FT)	42" RCP ARCH FLARED END FURNISH AND INSTALL (EACH)	24" CMP 16 GA FURNISH AND INSTALL (FT)	24" CMP 15 DEGREE ELBOW FURNISH AND INSTALL (EACH)	24" CMP FLARED END FURNISH AND INSTALL (EACH)	24" RCP TO CMP TRANSITION FURNISH AND INSTALL (EACH)	UNCLASS EX (CUYD)	BASE COURSE (TON)	ASPHALT CONCRETE COMPOSITE (TON)	REMOVE ASPHALT CONCRETE PAVEMENT (SQYD)	PIPE CULVERT UNDERCUT (CUYD)*	APPROXIMATE GPS COORDINATES		ASPHALT REMOVAL LENGTH CENTERED OVER PIPE (FEET) N.A.B.I.
																				NORTHING	EASTING	
SD 44	369	+	0.430	24" CMP w downspout	120	2	56	1			50	2	1	1	326	129.5	40.4	151.1	13.3	N 43.40034	E 97.58870	34
SD 44	383	+	0.880	Twin 42" CMP Arch 10 feet center to center	120	4			120	4					310	412.5	49.9	186.7	80	N 43.00910	E 97.30183	42
<b>TOTALS</b>					<b>240</b>	<b>6</b>	<b>56</b>	<b>1</b>	<b>120</b>	<b>4</b>	<b>50</b>	<b>2</b>	<b>1</b>	<b>1</b>	<b>636</b>	<b>542</b>	<b>90.3</b>	<b>337.8</b>	<b>93.3</b>			

\*Pipe Culvert Undercut quantity includes the area between the twin pipes but does not include pipe end sections or the CMP downspout section

# LAYOUT OF EMBANKMENT AND SURFACING AT SHALLOW CULVERTS BEING REPLACED

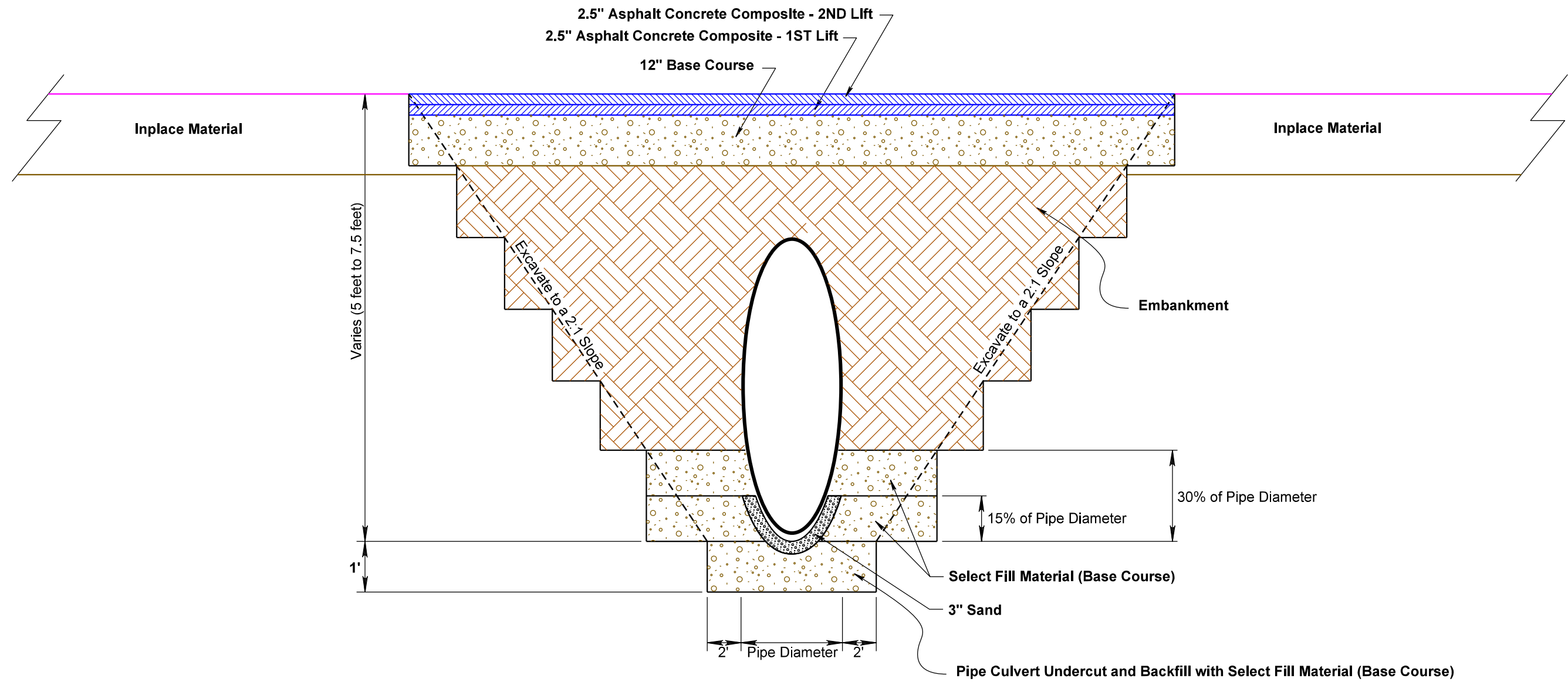

PLOT SCALE - 1:10

PLOTTED FROM - TRYAINT45

FILE - ... \DESIGN\16AF\_PIPE\PIPEX1.DGN

PLOT NAME - 1

**TOLERANCES IN DIMENSIONS**

Diameter:  $\pm 1.5\%$  for 24" Dia. or less and  $\pm 1\%$  or  $\frac{3}{8}$ " whichever is more for 27" Dia. or greater.  
 Diameters at joints:  $\pm \frac{3}{16}$ " for 30" Dia. or less and  $\pm \frac{1}{4}$ " for 36" or greater.  
 Length of joint (j):  $\pm \frac{1}{4}$ ".  
 Wall thickness (T): not less than design T by more than 5% or  $\frac{3}{16}$ ", whichever is greater.  
 Laying length: shall not underrun by more than  $\frac{1}{2}$ ".

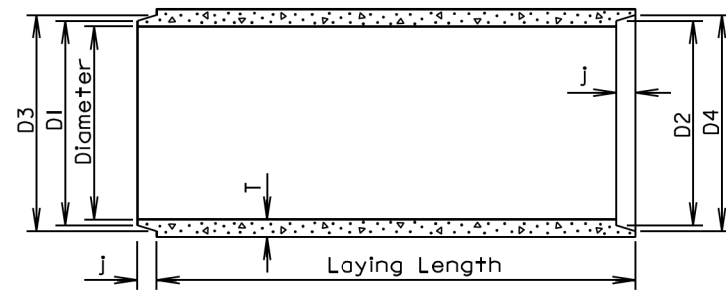

LONGITUDINAL SECTION

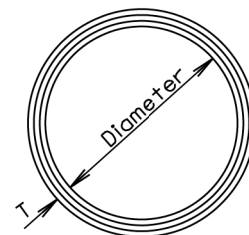

END VIEW

**GENERAL NOTES:**

Construction of R. C. P. shall conform to the requirements of Section 990 of the Specifications.

Not more than 2 four-foot sections shall be permitted near the ends of any culvert. Four-foot lengths shall be used only to secure the required length of culvert.

Diam. (in.)	Approx. Wt./Ft. (lb.)	T (in.)	J (in.)	D1 (in.)	D2 (in.)	D3 (in.)	D4 (in.)
12	92	2	1 3/4	13 1/4	13 5/8	13 3/8	14 1/4
15	127	2 1/4	2	16 1/2	16 7/8	17 1/4	17 5/8
18	168	2 1/2	2 1/4	19 5/8	20	20 3/8	20 3/4
21	214	2 3/4	2 1/2	22 1/8	23 1/4	23 3/4	24 1/8
24	265	3	2 3/4	26	26 3/8	27	27 3/8
27	322	3 1/4	3	29 1/4	29 5/8	30 1/4	30 5/8
30	384	3 1/2	3 1/4	32 3/8	32 3/4	33 1/2	33 7/8
36	524	4	3 3/4	38 3/4	39 1/4	40	40 1/2
42	685	4 1/2	4	45 1/8	45 5/8	46 1/2	47
48	867	5	4 1/2	51 1/2	52	53	53 1/2
54	1070	5 1/2	4 1/2	57 1/8	58 3/8	59 3/8	59 7/8
60	1296	6	5	64 1/4	64 3/4	66	66 1/2
66	1542	6 1/2	5 1/2	70 5/8	71 1/8	72 1/2	73
72	1810	7	6	77	77 1/2	79	79 1/2
78	2098	7 1/2	6 1/2	83 3/8	83 7/8	85 5/8	86 1/8
84	2410	8	7	89 3/4	90 1/4	92 1/8	92 5/8
90	2740	8 1/2	7	95 3/4	96 1/4	98 1/8	98 5/8
96	2950	9	7	102 1/8	102 5/8	104 1/2	105
102	3075	9 1/2	7 1/2	109	109 1/2	111 1/2	112
108	3870	10	7 1/2	115 1/2	116	118	118 1/2

June 26, 2015

<b>S D D O T</b>	<b>REINFORCED CONCRETE PIPE</b>	PLATE NUMBER 450.01
	Published Date: 1st Qtr. 2021	Sheet 1 of 1

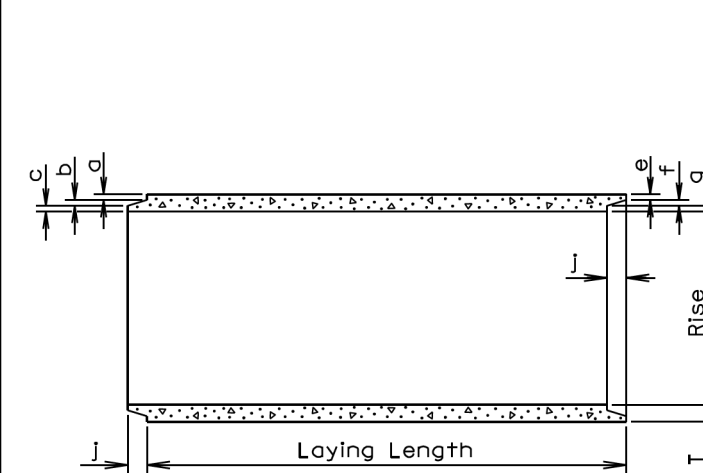

LONGITUDINAL SECTION

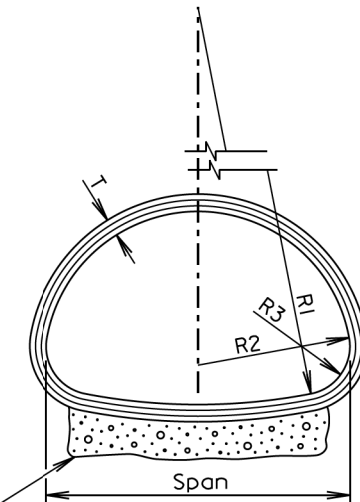

END VIEW

**TOLERANCES IN DIMENSIONS**

Radial dimensions at joints:  $\pm \frac{1}{8}$ " for 65" span or less and  $\pm \frac{1}{4}$ " for longer spans.  
 Rise and Span:  $\pm 2\%$  of tabular values.  
 Length of Joint (J):  $\pm \frac{1}{4}$ ".  
 Wall thickness (T): not less than design T by more than 5% or  $\frac{3}{16}$ ", whichever is greater.  
 Laying length: shall not underrun by more than  $\frac{1}{2}$ ".

Gravel Bedding Material shall be supplied for 102" to 169" spans. It shall be placed to a thickness of 6" (Min.) x 85% of the Span x Length of culvert and shall conform to the gradation requirements for gravel surfacing except material may be screened or may be plan provided material.

* Size (in.)	Approx. Wt./Ft. (lb.)	Rise (in.)	Span (in.)	T (in.)	a (in.)	b (in.)	c (in.)	j (in.)	e (in.)	f (in.)	g (in.)	R1 (in.)	R2 (in.)	R3 (in.)
18	170	13 1/2	22	2 1/2	1 3/8	3/8	3/4	2	1 1/8	3/8	1	27 1/2	13 3/4	5 1/4
24	320	18	28 1/2	3 1/2	1 5/8	1/2	1 3/8	3	1 3/8	1/2	1 5/8	40 1/16	14 3/4	4 5/8
30	450	22 1/2	36 1/4	4	1 13/16	5/8	1 9/16	3 1/2	1 9/16	5/8	1 13/16	51	18 3/4	6 1/8
36	600	26 5/8	43 3/4	4 1/2	2	3/4	1 3/4	4	1 3/4	3/4	2	62	22 1/2	6 1/2
42	740	31 5/16	51 1/8	4 1/2	2	3/4	1 3/4	4	1 3/4	3/4	2	73	26 1/4	7 3/4
48	890	36	58 1/2	5	2 1/4	3/4	2	5	2	3/4	2 1/4	84	30	8 7/8
54	1100	40	65	5 1/2	2 1/2	3/4	2 1/4	5	2 1/4	3/4	2 1/2	92 1/2	33 3/8	10
60	1400	45	73 1/2	6	3 5/16	3/4	1 5/16	5	2 3/4	3/4	2 1/2	105	37 1/2	11
72	1900	54	88	7	3 13/16	1	2 3/16	6	3 1/4	1	2 3/4	126	45	13 5/16
84	2500	62	102	8	4 1/8	1	2 7/8	6	3 1/2	1	3 1/2	162 1/2	52	14 1/2
96	3300	78	122 3/8	9	4 1/2	1	3 1/2	7	4	1	4	218	62	20
108	4200	88	138 1/2	10	5	1	4	7	4 1/2	1	4 1/2	269	70	22
120	5100	96 7/8	154	11	5 1/2	1	4 1/2	7	5	1	5	301 3/8	78	24
132	5100	106 1/2	168 3/4	10		1	4	7	4 1/2	1	4 1/2	329	85 5/8	26 7/8

\* Equivalent Diameter of Circular R. C. P.

**GENERAL NOTES:**

Construction of R.C.P. Arch shall conform to the requirements of Section 990 of the Specifications. Not more than 2 four-foot sections shall be permitted near the ends of any culvert. Four-foot lengths shall be used only to secure the required length of culvert.

June 26, 2015

<b>S D D O T</b>	<b>REINFORCED CONCRETE PIPE ARCH</b>	PLATE NUMBER 450.02
	Published Date: 1st Qtr. 2021	Sheet 1 of 1



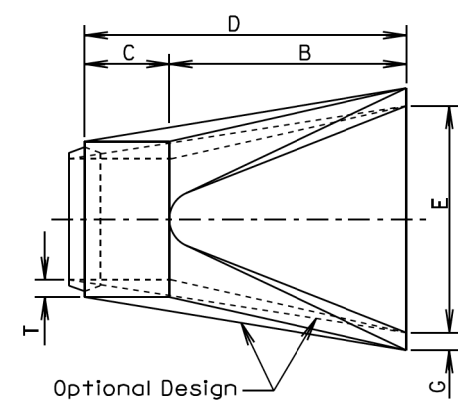

TOP VIEW

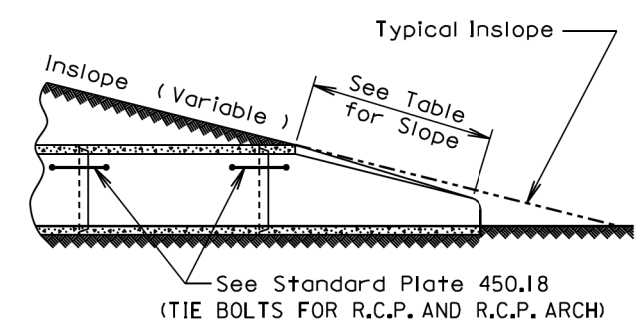

SLOPE DETAIL

**GENERAL NOTES:**  
 Lengths of concrete pipe shown on plan sheets are between flared ends only.  
 Construction of R.C.P. Flared End shall conform to the requirements of Section 990 of the Specifications.

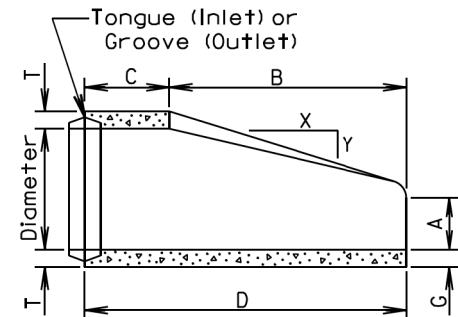

LONGITUDINAL SECTION

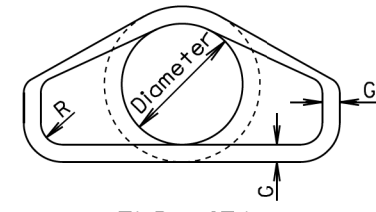

END VIEW

Dia. (in.)	Approx. Wt. of Section (lbs.)	Approx. Slope (X to Y)	T (in.)	A (in.)	B (in.)	C (in.)	D (in.)	E (in.)	G (in.)	R (in.)
12	530	2.4:1	2	4	24	48 1/8	72 7/8	24	2	1 1/2
15	740	2.4:1	2 1/4	6	27	46	73	30	2 1/4	1 1/2
18	990	2.3:1	2 1/2	9	27	46	73	36	2 1/2	1 1/2
21	1280	2.4:1	2 3/4	9	36	37 1/2	73 1/2	42	2 3/4	1 1/2
24	1520	2.5:1	3	9 1/2	43 1/2	30	73 1/2	48	3	1 1/2
27	1930	2.5:1	3 1/4	10 1/2	49 1/2	24	73 1/2	54	3 1/4	1 1/2
30	2190	2.5:1	3 1/2	12	54	19 3/4	73 3/4	60	3 1/2	1 1/2
36	4100	2.5:1	4	15	63	34 3/4	97 3/4	72	4	1 1/2
42	5380	2.5:1	4 1/2	21	63	35	98	78	4 1/2	1 1/2
48	6550	2.5:1	5	24	72	26	98	84	5	1 1/2
54	8240	2:1	5 1/2	27	65	33 1/4	98 1/4	90	5 1/2	1 1/2
60	8730	1.9:1	6	35	60	39	99	96	5	1 1/2
66	10710	1.7:1	6 1/2	30	72	27	99	102	5 1/2	1 1/2
72	12520	1.8:1	7	36	78	21	99	108	6	1 1/2
78	14770	1.8:1	7 1/2	36	90	21	111	114	6 1/2	1 1/2
84	18160	1.6:1	8	36	90 1/2	21	111 1/2	120	6 1/2	1 1/2
90	20900	1.5:1	8 1/2	41	87 1/2	24	111 1/2	132	6 1/2	6

June 26, 2015

<b>S D D O T</b>	<b>R. C. P. FLARED ENDS</b>	PLATE NUMBER <b>450.10</b>
	Published Date: 1st Qtr. 2021	Sheet 1 of 1

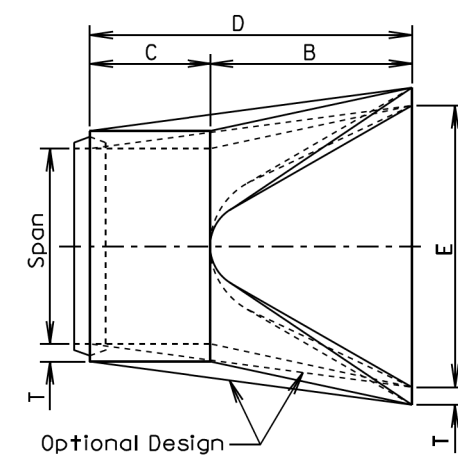

TOP VIEW

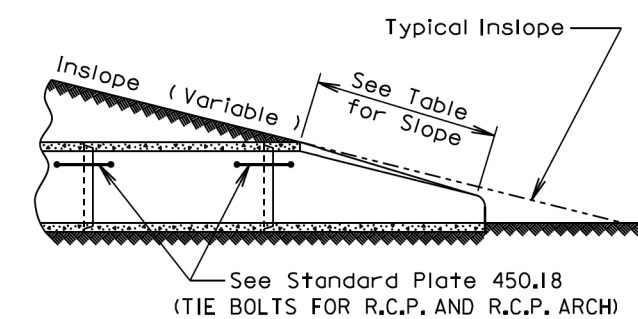

SLOPE DETAIL

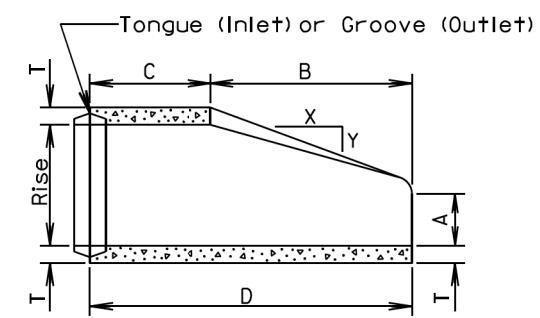

LONGITUDINAL SECTION

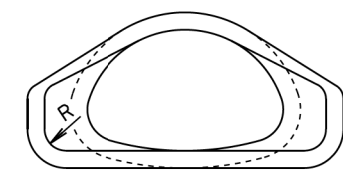

END VIEW

**GENERAL NOTES:**  
 Lengths of concrete pipe shown on plan sheets are between flared ends only.  
 Construction of R.C.P. Arch Flared End shall conform to the requirements of Section 990 of the Specifications.

* Size (in.)	Approximate Weight of Section (lbs.)	Rise (in.)	Span (in.)	Slope (X:Y)	T (in.)	A (in.)	B (in.)	C (in.)	D (in.)	E (in.)	R (in.)
18	1100	13 1/2	22	3:1	2 1/2	7	27	45	72	36	2
24	1750	18	28 1/2	3:1	3 1/2	8 1/2	39	33	72	48	3
30	3300	22 1/2	36 1/4	3:1	4	9 1/2	50	46	96	60	3
36	4350	26 5/8	43 3/4	3:1	4 1/2	11 1/8	60	36	96	72	6
42	5250	31 5/16	51 1/8	3:1	4 1/2	15 13/16	60	36	96	78	6
48	6400	36	58 1/2	3:1	5	21	60	36	96	84	6
54	7850	40	65	3:1	5 1/2	25 1/2	60	36	96	90	6
60	9500	45	73 1/2	3:1	6	31	60	36	96	96	6
72	13550	54	88	2:1	7	31	60	39	99	120	6
84	17950	62	102	2:1	8	28 1/2	83	19	102	144	6

\*Equivalent Diameter of Circular R. C. P.

June 26, 2015

<b>S D D O T</b>	<b>R. C. P. ARCH FLARED ENDS</b>	PLATE NUMBER <b>450.11</b>
	Published Date: 1st Qtr. 2021	Sheet 1 of 1

Wall "t" (in.)	Rod Dia. (in.)	Pipe Sleeve Dia. (nominal)
≤ 3/4	5/8	3/4
3/2-6/2	3/4	1
≥ 7	1	1 1/4

**GENERAL NOTES:**

Tie bolts shall conform to ASTM F1554 Grade 36 or ASTM A36. Nuts shall be heavy hex conforming to ASTM A563. Washers shall conform to ASTM F436.

Pipe Sleeve shall conform to ASTM A500 or A53, Grade B.

Galvanize adjustable eye bolt tie assembly in accordance with ASTM A153.

ASTM F1554 Grade 36 or ASTM A36 Tie Bolt with 2 Heavy Hex Nuts and 2 Washers

ASTM F1554 Grade 36 or ASTM A36 Rod with Heavy Hex Nut and Washer

**ADJUSTABLE EYE BOLT TIE**

Pipe Dia. (in.)	"L" (in.)	Bolt Dia. (in.)
≤ 48	4	3/4
> 48	6	1

**GENERAL NOTES:**

Angles shall conform to ASTM A36.

Bolts shall conform to ASTM A307. Nuts shall be heavy hex conforming to ASTM A563. Washers shall conform to ASTM F436.

Galvanize angles, bolts, nuts, and washers in accordance with ASTM A153.

ASTM A307 Bolt with Heavy Hex Nut and 2 Washers

**ANGLE AND BOLT TIE**

**GENERAL NOTES:**

In lieu of the tie bolts detailed above other types of tie bolt connections may be installed as approved by the Office of Bridge Design.

All pipe sections of R.C.P. and R.C.P. Arch shall be tied with tie bolts except for pipe located between drop inlets, manholes, and junction boxes. All pipe sections of pipes that only enter or exit drop inlets, manhole, and junction boxes shall be tied with tie bolts.

There will be no separate measurement or payment for the tie bolts. The cost for furnishing and installing the tie bolts shall be incidental to the contract unit price per foot for the corresponding bid item for R.C.P. or R.C.P. Arch.

**END VIEW "CIRCULAR"**

**END VIEW "ARCH"**

February 28, 2013

Diameter	A	L	Diameter	A	L	Diameter	A	B	C	L
Inches	Feet	Feet	Inches	Feet	Feet	Inches	Inches			Feet
12	1	2	12	2	4	12	25 1/2	11	18 1/2	4
15	1	2	15	2	4	15	26 1/2	12	18	4
18	1	2	18	2	4	18	27	14	17	4
21	2	4	21	2	4	21	27	15	16 1/2	4
24	2	4	24	2	4	24	27 1/2	16	16	4
27	2	4	27	2	4	27	27 1/2	17	15 1/2	4
30	2	4	30	3	6	30	40	19	26 1/2	6
33	2	4	33	3	6	33	40	20	26	6
36	2	4	36	3	6	36	40 1/2	21	25 1/2	6
42	2	4	42	3	6	42	41	23	24 1/2	6
48	2	4	48	4	8	48	53 1/2	26	35	8
54	3	6	54	4	8	54	54	28	34	8
60	3	6	60	4	8	60	54 1/2	31	32 1/2	8
66	3	6	66	4	8	66	54	33	31 1/2	8
72	3	6	72	5	10	72	67 1/2	36	42	10
78	3	6	78	5	10	78	68	39	40 1/2	10
84	3	6	84	5	10	84	68 1/2	41	39 1/2	10
90	3	6	90	6	12	90	70	46	37	10
96	3	6	96	6	12	96	82	46	49	12

**FABRICATED ELBOW LENGTHS FOR ALL CORRUGATIONS**

**GENERAL NOTES:**

All dimensions shown are nominal.

L = Linear Feet of C.M.P. required to fabricate fitting.

June 26, 2001

Alternate Type Connector Sections may be used with approval of the Engineer.

Dia. D (in.)	Ga.	DIMENSIONS (in.)					Approx. Slope	Body
		A	B	H	L	W		
12	16	6	6	6	21	24	2 1/2:1	1 Pc.
15	16	7	8	6	26	30	2 1/2:1	1 Pc.
18	16	8	10	6	31	36	2 1/2:1	1 Pc.
21	16	9	12	6	36	42	2 1/2:1	1 Pc.
24	16	10	13	6	41	48	2 1/2:1	1 Pc.
30	14	12	16	8	46	60	2 1/2:1	1 Pc.
36	14	14	19	9	51	72	2 1/2:1	2 Pc.
42	12	16	22	11	60	84	2 1/2:1	2 Pc.
48	12	18	27	12	69	90	2 1/4:1	2 Pc.
54	12	18	30	12	78	102	2:1	3 Pc.
60	12	18	33	12	84	114	1 3/4:1	3 Pc.
66	12	18	36	12	87	120	1 1/2:1	3 Pc.
72	12	18	39	12	87	126	1 1/3:1	3 Pc.
78	12	18	42	12	87	132	1 1/4:1	3 Pc.
84	12	18	45	12	87	138	1 1/6:1	3 Pc.

**STANDARD CONNECTIONS**

Threaded 5/8" Dia. Rod over Top of culvert Pipe  
Bolted on Side Lug  
Dimple Band Collar bolted to end section with 3/8" bolts  
Alternate for all sizes

For 30" through 84"

Pipe Strap Bolt  
Flat Strap Connector  
For 12" through 24" only

**TUBING ATTACHMENT DETAILS SECTION A-A**

1" O.D. 14 Ga. Galv. Tubing  
Sheet  
3/8" x 1/2" Gal. Buttonhead Rivets spaced 6" C. to C. Overall length of rivets=0.78"

**NOTE:**  
Tubing is slipped over the sheet and rivets or lugs prior to forming operations of the apron.

**TYPICAL CROSS-SECTION**

**SECTION A-A (alternate)**  
Half Punches (Lugs)  
1 1/2" (Max.)  
1 3/16"  
1/8"

**SECTION A-A (alternate)**  
1/2" I.D. (Metal Edge)

**GENERAL NOTES:**  
All 3 pc. bodies shall have 12 Ga. sides and 10 Ga. center panels. Width of center panels shall be greater than 20% of the pipe periphery. Multiple panel bodies to have lap seams tightly joined by 3/8" Dia. galvanized rivets or bolts.  
For 60" through 84" sizes, reinforced edges shall be supplemented with galvanized stiffener angles. The angles will be 2" x 2" x 1/4" for 60" through 72" diameters and 2 1/2" x 2 1/2" x 1/4" for 78" and 84" diameters. The angles shall be attached by 3/8" diameter galvanized nuts and bolts.  
Rivets and Bolts shall be 3/8" Dia. Min. for 10 Ga. and 12 Ga. sheet, and 5/16" Dia. Min. for 14 Ga. and 16 Ga. sheets. Tighten nuts with torque wrench to 25 lbs. torque.

March 31, 2000



**SDDOT**  
**C.M.P. FLARED ENDS**  
PLATE NUMBER 450.35  
Sheet 1 of 1  
Published Date: 1st Qtr. 2021

**GENERAL NOTE:**  
Arch pipe transitions shall be fabricated similar to the round transition shown above.

March 31, 2000

**SDDOT**  
**C.M.P. TO R.C.P. TRANSITION AND R.C.P. TO C.M.P. TRANSITION**  
PLATE NUMBER 450.50  
Sheet 1 of 1  
Published Date: 1st Qtr. 2021

Posted Speed Prior to Work (M.P.H.)	Spacing of Advance Warning Signs (Feet) (A)	Spacing of Channelizing Devices (Feet) (G)
0 - 30	200	25
35 - 40	350	25
45	500	25
50	500	50
55	750	50
60 - 65	1000	50

 Flagger  
 Channelizing Device

For low-volume traffic situations with short work zones on straight roadways where the flagger is visible to road users approaching from both directions, a single flagger may be used.

The ROAD WORK AHEAD and the END ROAD WORK signs may be omitted for short duration operations (1 hour or less).

For tack and/or flush seal operations, when flaggers are not being used, the FRESH OIL sign (W21-2) shall be displayed in advance of the liquid asphalt areas.

Flashing warning lights and/or flags may be used to call attention to the advance warning signs.

The channelizing devices shall be drums or 42" cones.

Channelizing devices are not required along the centerline adjacent to work area when pilot cars are utilized for escorting traffic through the work area.

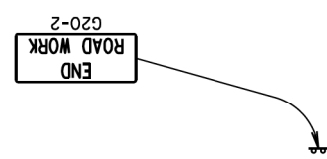

Channelizing devices and flaggers shall be used at intersecting roads to control intersecting road traffic as required.

The buffer space should be extended so that the two-way traffic taper is placed before a horizontal or vertical curve to provide adequate sight distance for the flagger and queue of stopped vehicles.

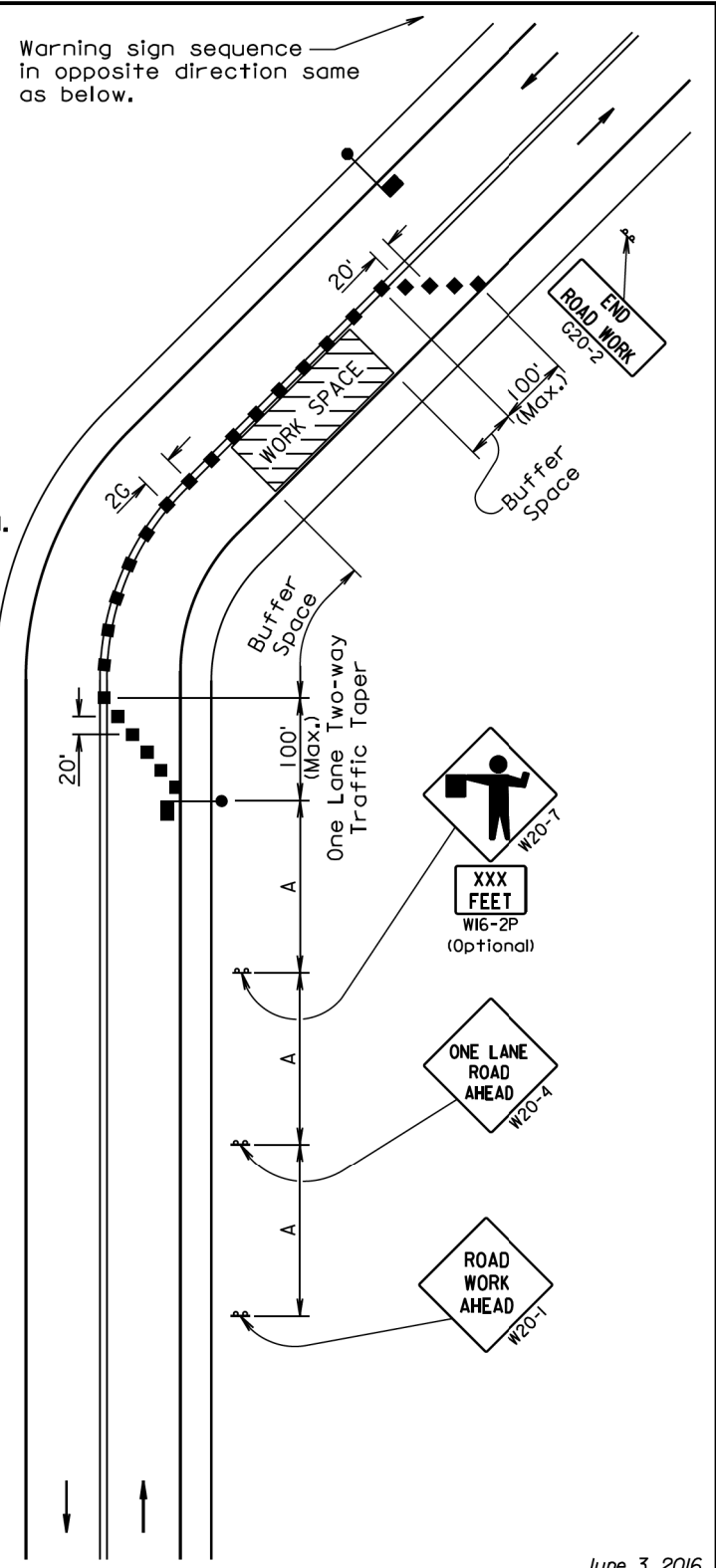

The length of A may be adjusted to fit field conditions.

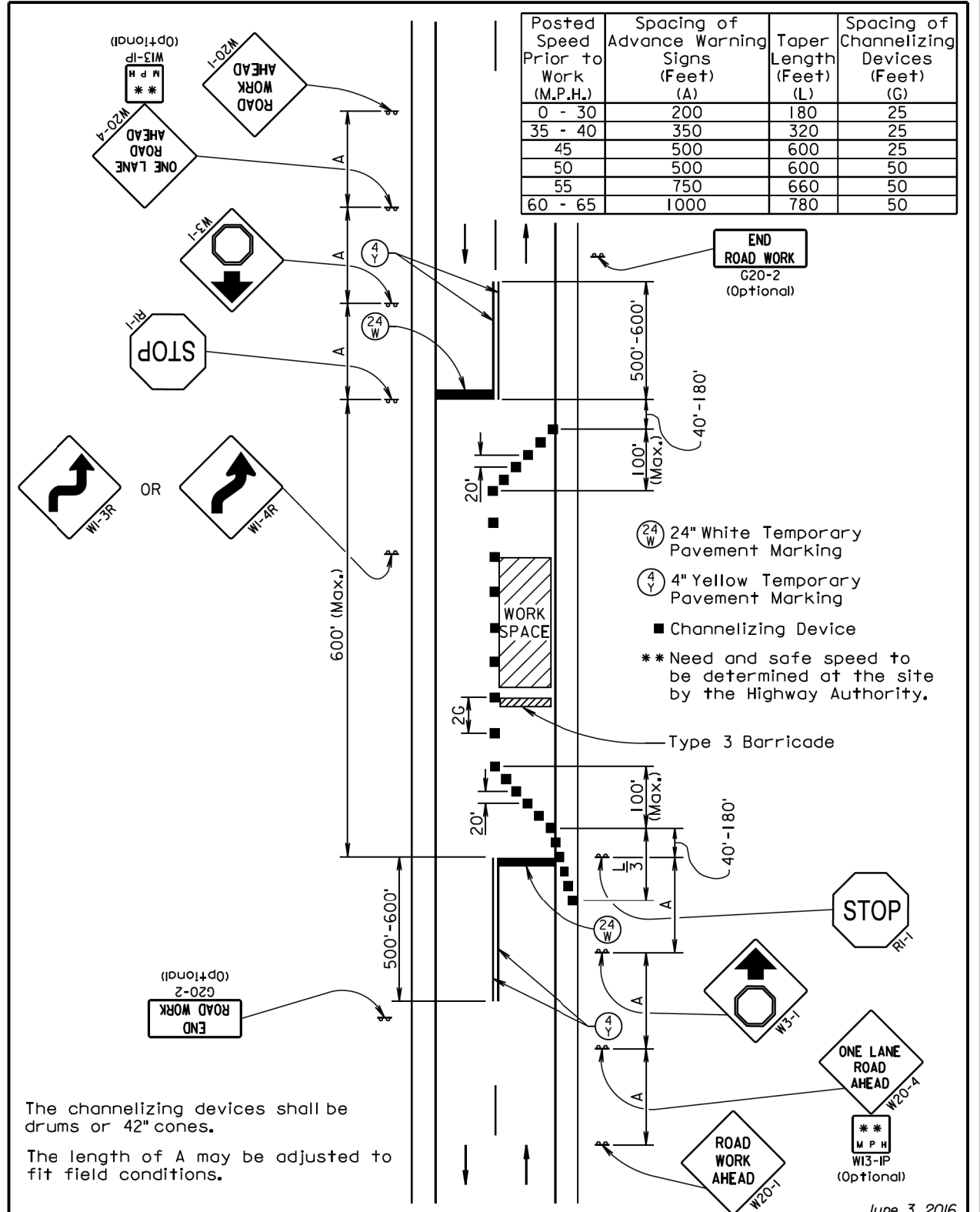

June 3, 2016



Posted Speed Prior to Work (M.P.H.)	Spacing of Advance Warning Signs (Feet) (A)	Taper Length (Feet) (L)	Spacing of Channelizing Devices (Feet) (G)
0 - 30	200	180	25
35 - 40	350	320	25
45	500	600	25
50	500	600	50
55	750	660	50
60 - 65	1000	780	50

 24" White Temporary Pavement Marking  
 4" Yellow Temporary Pavement Marking  
 Channelizing Device  
 \*\* Need and safe speed to be determined at the site by the Highway Authority.

The channelizing devices shall be drums or 42" cones.

The length of A may be adjusted to fit field conditions.

The length of A may be adjusted to fit field conditions.

June 3, 2016

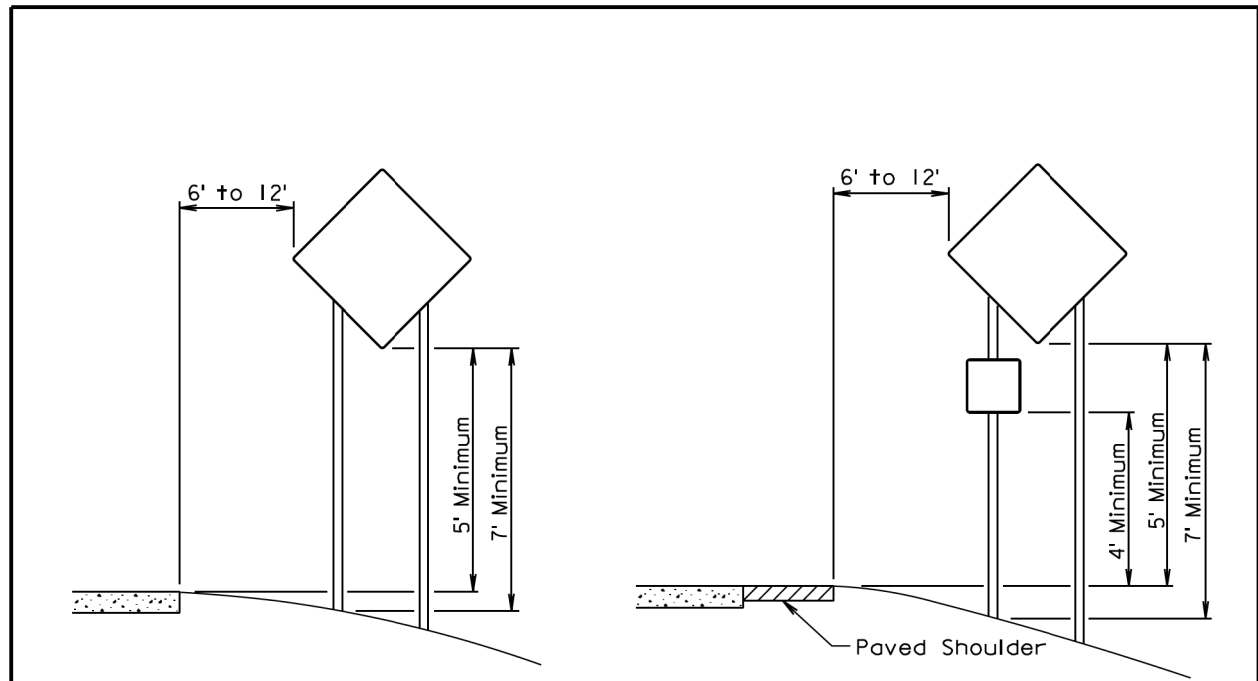

RURAL DISTRICT

RURAL DISTRICT WITH  
SUPPLEMENTAL PLATE

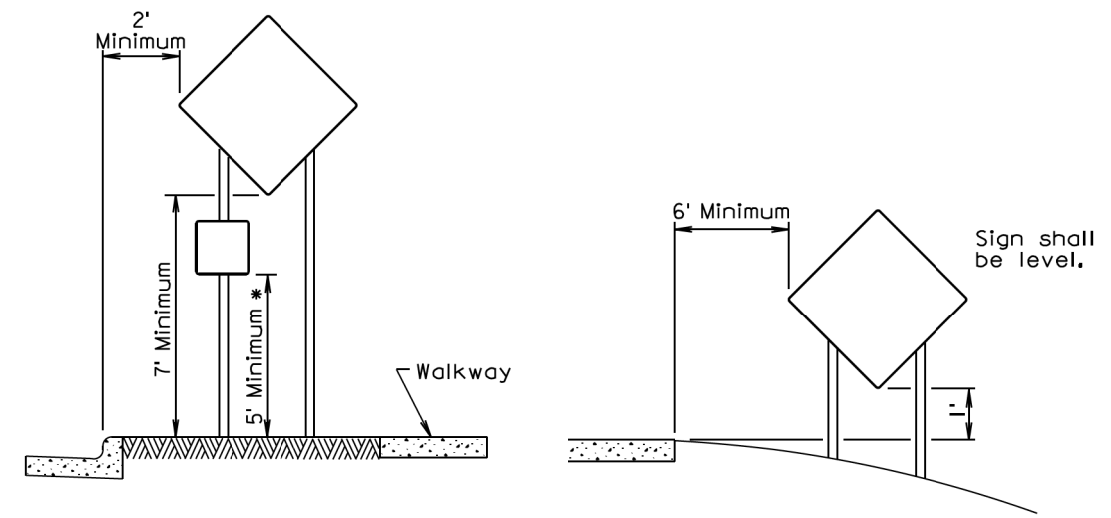

URBAN DISTRICT

RURAL DISTRICT  
3 DAY MAXIMUM  
(Not applicable to regulatory signs)

\* If the bottom of supplemental plate is mounted lower than 7 feet above a pedestrian walkway, the supplemental plate should not project more than 4" into the pedestrian facility.

September 22, 2014

Published Date: 1st Qtr. 2021	S D D O T	CRASHWORTHY SIGN SUPPORTS (Typical Construction Signing)	PLATE NUMBER 634.85
			Sheet 1 of 1

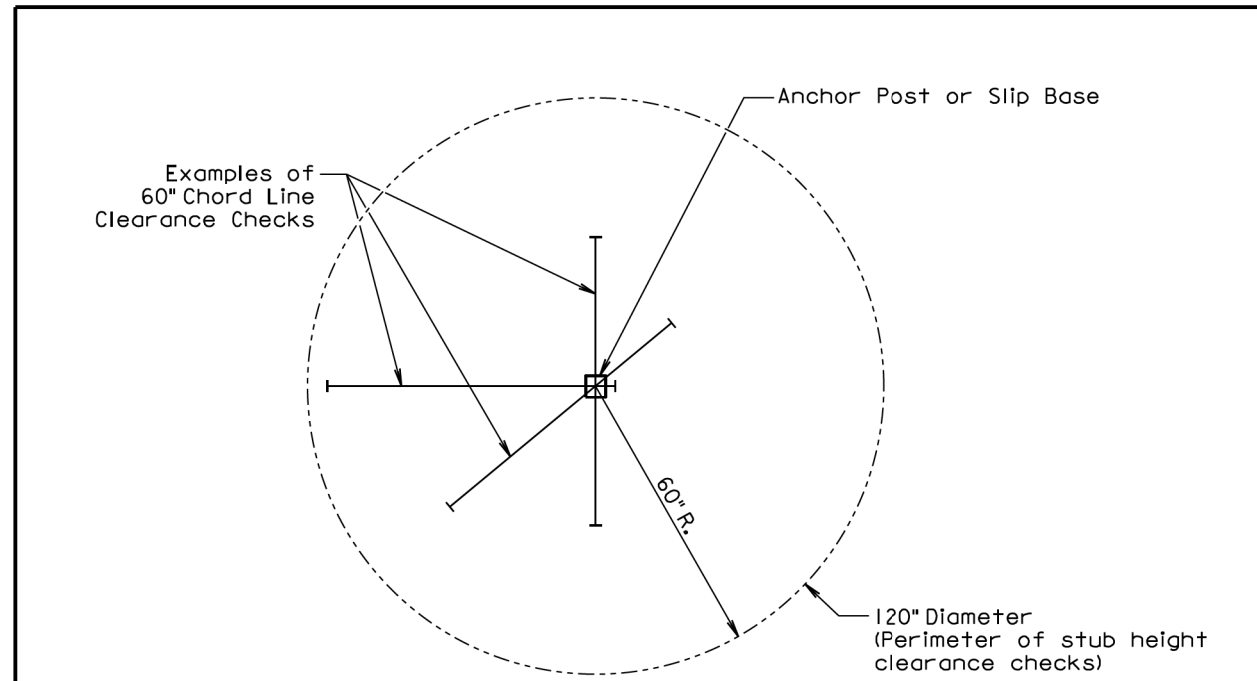

PLAN VIEW  
(Examples of stub height clearance checks)

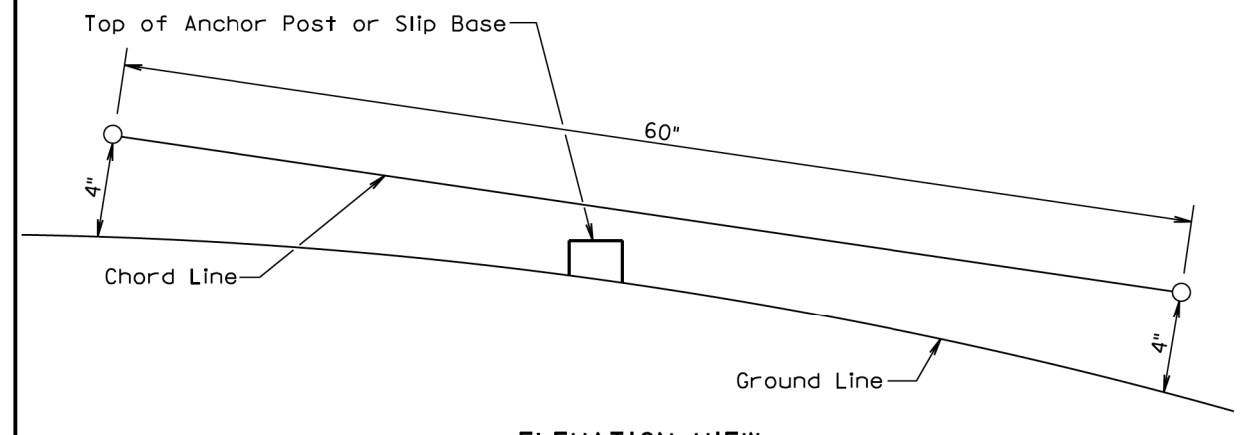

ELEVATION VIEW

GENERAL NOTES:

The top of anchor posts and slip bases SHALL NOT extend above a 60" chord line within a 120" diameter circle around the post with ends 4" above the ground.  
At locations where there is curb and gutter adjacent to the breakaway sign support, the stub height shall be a maximum of 4" above the ground line at the localized area adjacent to the breakaway support stub.  
The 4" stub height clearance is not necessary for U-channel lap splices where the support is designed to yield (bend) at the base.

July 1, 2005

Published Date: 1st Qtr. 2021	S D D O T	BREAKAWAY SUPPORT STUB CLEARANCE	PLATE NUMBER 634.99
			Sheet 1 of 1