

PLOT SCALE - 200,000,000:1

PLOTTED FROM - TRRC\INT23

STATE OF SOUTH DAKOTA
DEPARTMENT OF TRANSPORTATION

PLANS FOR PROPOSED

PROJECT 410D334
R.C. MAINTENANCE YARD
PENNINGTON COUNTY

C.I.P. RETAINING WALL SALT/SAND DIVIDER
PCN 126q

STATE OF SOUTH DAKOTA	PROJECT	SHEET NO.	TOTAL SHEETS
	410D334	1	7

Plotting Date: 18-APR-2011

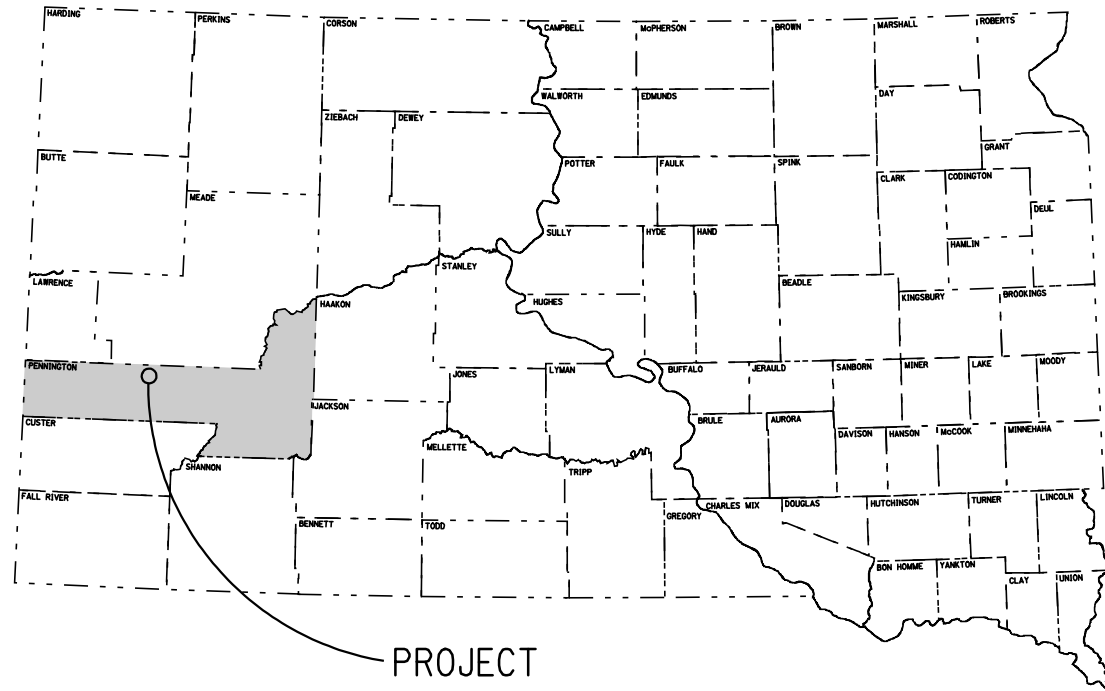

INDEX OF SHEETS

- Sheet No. 1: Title Sheet
- Sheet No. 2: Estimate of Quantities and Notes
- Sheet No. 3: Notes (continued)
- Sheet No. 4: Retaining Wall Layout
- Sheet No. 5: Details for Panel 1
- Sheet No. 6: Details for Panels 2, 3, & 4
- Sheet No. 7: Details for All Panels

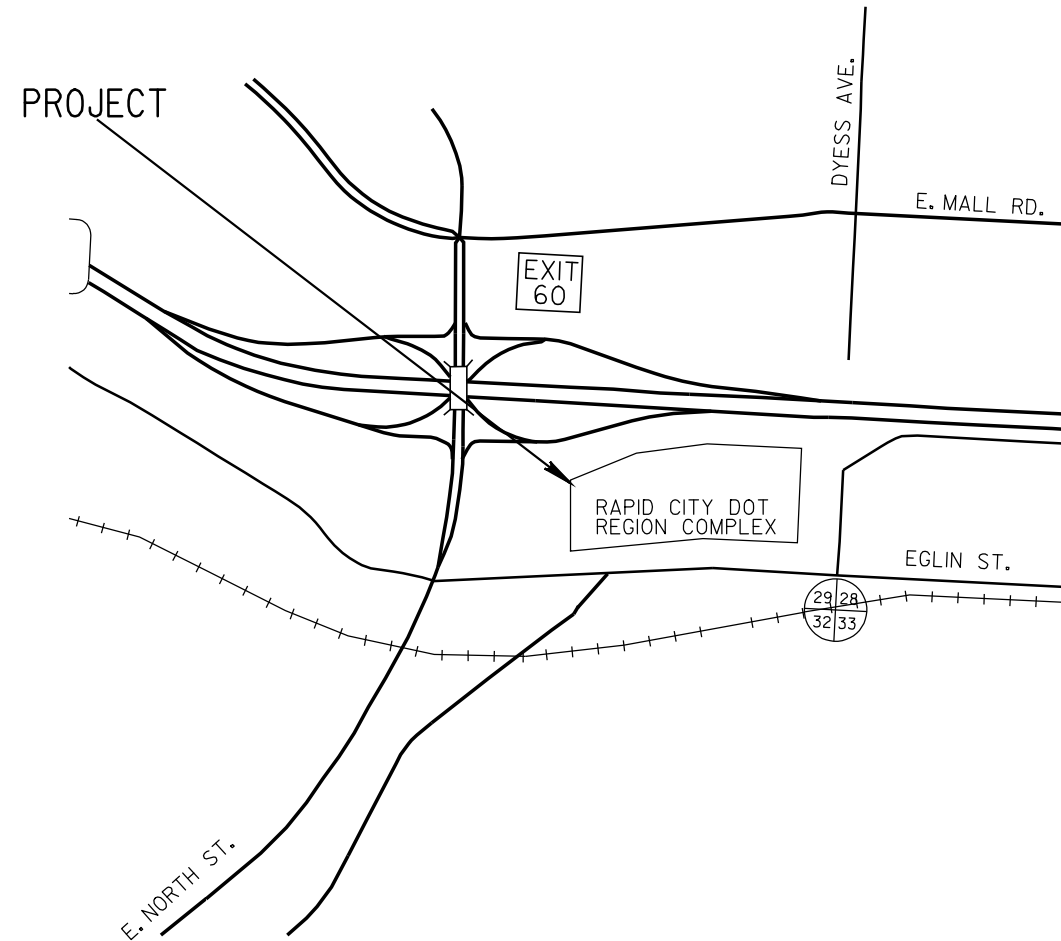

FILE - U:\REGION\RC\PR\2011\BUILDING\BUDGET\PLANS\126Q RC SALT-SAND DIVIDER\BUDGET\INDEX 1

STATE OF SOUTH DAKOTA	PROJECT	SHEET	TOTAL SHEETS
	410D334	2	7

ESTIMATE OF QUANTITIES

Item number	Item	Quantity	Unit
009E0010	Mobilization	Lump Sum	LS
110E1010	Remove Asphalt Concrete Pavement	102.1	Sq.Yd.
260E1010	Base Course	53.6	Ton
320E1200	Asphalt Concrete Composite	29.8	Ton
420E0300	Structure Excavation, Retaining Wall	86.2	Cu.Yd.
460E0380	Install Dowel in Concrete	8	Each
462E0100	Class M6 Concrete	88.2	Cu.Yd.
480E0200	Epoxy Coated Reinforcing Steel	10578	Lb.

SCOPE OF WORK

Construct new reinforced concrete retaining wall in existing salt/sand storage building to provide storage separation of salt and salt/sand mixture. New retaining wall height is 8' above finished grade. New retaining wall length is 115'-4".

SPECIFICATIONS

Design Specifications: AASHTO Standard Specifications for Highway Bridges 2002 Edition with 2003 Interim Specifications (Load Factor Design).

Standard Specifications for Roads & Bridges, 2004 Edition and Required Provisions, Supplemental Specifications and/or Special Provisions as included in the Proposal.

DESIGN LOADS

Retained materials:

Salt: $\gamma = 80 \text{ pcf}$ $\phi = 32^\circ$

Salt/sand mixture: $\gamma = 110 \text{ pcf}$ $\phi = 30^\circ$

The new retaining wall is designed for retaining the above materials to the top wall with sloping backfill above the wall. The material can be retained on either side of the wall or on both sides of the wall at the same time.

SOIL PARAMETERS

Silt-Clay foundation soils:

Soil parameters: $\gamma = 120 \text{ pcf}$ $\phi = 20^\circ$ $c = 300$

Footing allowable loading pressure: 2000 psf

Base course parameters: $\gamma = 135 \text{ pcf}$ $\phi = 32^\circ$ $c = 0$

UTILITIES

The Contractor shall contact the involved utility companies through South Dakota One Call (1-800-781-7474) prior to starting work. It shall be the responsibility of the Contractor to coordinate work with the utility owners to avoid damage to existing facilities.

DESIGN MIX OF CONCRETE

All concrete shall be Class M6 and conform to Section 462 of the Standard Specification.

GENERAL CONSTRUCTION

1. All reinforcing steel shall be epoxy coated and shall conform to ASTM A615, Grade 60. The epoxy coating shall conform to AASHTO M284. All reinforcing, except D and D1, bars shall be deformed. D and D1 bars shall be smooth.

2. All exposed concrete corners and edges shall be chamfered 3/4" unless noted otherwise.

3. Use clear cover on reinforcing steel as shown.

4. The excavation for the reinforced concrete retaining wall shear (base) key shall be neat lined and the concrete cast against undisturbed earth. Excavation shall be by trenching or other approved means. Minimum shear key width shall be sixteen inches. The shear key joint surface between the shear key and the bottom of the reinforced concrete retaining wall footing shall be rough floated sufficiently to thoroughly consolidate the surface and intentionally left in a roughened condition.

5. The sides and bottom of the excavation for the base course below the retaining wall shall be neat lined and the base course placed against undisturbed earth.

6. The excavation for the sides of the reinforced concrete retaining wall footing shall be neat lined and the concrete cast against undisturbed earth.

7. The joint surface between the top of the reinforced concrete retaining wall footing and the bottom of the reinforced retaining wall shall be rough floated sufficiently to thoroughly consolidate the surface and intentionally left in a roughened condition.

8. Costs of the preformed expansion joint filler, keyway installation, bituminous coatings and styrofoam blockouts shall be incidental to the contract unit price per cubic yard for "Class M6 Concrete".

9. Structure excavation is the volume of the neat lined excavation below the bottom of the existing asphalt pavement removal.

10. The exposed retaining wall surfaces shall receive a finish in accordance with 460.3M of the Standard Specifications.

IN-PLACE ASPHALT CONCRETE REMOVAL

The existing asphalt concrete shall be removed above the neat lines of the excavation required for construction of the reinforced concrete retaining wall. Existing asphalt thickness is estimated to be 6". The existing asphalt shall be vertically saw-cut full depth at the limits of the work as detailed in the plans.

All costs for saw-cutting, removing, and disposal of in-place asphalt material shall be included in the contract unit price per square yard for "Remove Asphalt Concrete Pavement".

ASPHALT CONCRETE COMPOSITE

Mineral aggregate for the Asphalt Concrete Composite shall conform to the requirements of the Standard Specifications for Class E, Type 1.

All other requirements in the Standard Specifications for Asphalt Concrete Composite shall apply.

The asphalt binder used in the mixture shall be PG 64-22, PG 64-28 or PG 64-34 Asphalt Binder.

Place three 2" lifts of asphalt.

BASE COURSE

Base Course shall be furnished by the Contractor.

The aggregate base course shall be placed in lifts not exceeding 4" and compacted to 97% of the maximum dry density. All other requirements of the Standard Specifications for Base Course shall apply.

ESTIMATE OF QUANTITIES AND NOTES
FOR
C.I.P. RETAINING WALL
SALT / SAND DIVIDER
SALT / SAND STORAGE BUILDING
WIP #410D334
PCN i26q

RAPID CITY, SOUTH DAKOTA
S. D. DEPT. OF TRANSPORTATION
APRIL 2011

STATE OF SOUTH DAKOTA	PROJECT	SHEET	TOTAL SHEETS
	410D334	3	7

INSTALLING DOWELS IN CONCRETE

1. Holes drilled in the existing concrete shall be true and normal or as shown in the plans. Drilling holes using a core drill shall not be allowed. Care shall be taken not to damage the existing reinforcing steel. The Contractor can still expect to encounter and have to drill through reinforcing steel or shift the dowel spacing as approved by the Engineer to miss the existing reinforcing steel. If the Contractor shifts the dowel spacing, the unused drill holes shall be completely filled with the epoxy resin specified in note number 2 under "Installing Dowels in Concrete" as approved by the Engineer.
2. The epoxy resin mixture shall be of a type for bonding steel to hardened concrete and shall conform to AASHTO M235 Type IV, Grade 3 (Equivalent to ASTM C881, Type IV, Grade 3). Grade 1, 2 or 3 may be used for vertical dowels and Grade 3 epoxy shall be used for all horizontal dowels.
3. The diameter of the drilled holes shall not be less than 1/8 inch greater, nor more than 3/8 inch greater than the diameter of the dowels or as per the Manufacturer's recommendations. Holes shall not be drilled using core bits. The drilled holes shall be blown out with compressed air using a device that will reach the back of the hole to ensure that all debris or loose material has been removed prior to epoxy injection.
4. Mix epoxy resin as recommended by the Manufacturer and apply by an injection method as approved by the Engineer. Beginning at the back of the drilled holes, fill the holes 1/3 to 1/2 full of epoxy, or as recommended by the Manufacturer, prior to insertion of the steel bar. Use epoxy resin intended for horizontal dowel installation. Care shall be taken to prevent epoxy from running out of the horizontal holes prior to steel bar insertion. Rotate the steel bar during installation to eliminate voids and ensure complete bonding of the bar. Insertion of the bars by the dipping or painting method will not be allowed.
5. No loads shall be applied to the epoxy grouted dowel bars until the epoxy resin has had sufficient time to cure as specified by the epoxy resin manufacturer.
6. Dowel bars shall be smooth bars conforming to ASTM A615 Grade 60.
7. The cost of epoxy resin, dowels, installation and other incidental items shall be incidental to the contract unit price per each for "Install Dowel in Concrete".

WASTE DISPOSAL SITE

The Contractor will be required to furnish a site(s) for the disposal of construction/demolition debris generated by this project.

Construction/demolition debris may not be disposed of within the State ROW or on DOT PROPERTY.

The waste disposal site(s) shall be managed and reclaimed in accordance with the following from the General Permit for Highway, Road, and Railway Construction/Demolition Debris Disposal Under the South Dakota Waste Management Program issued by the Department of Environment and Natural Resources.

The waste disposal site(s) shall not be located in a wetland, within 200 feet of surface water, or in an area that adversely affects wildlife, recreation, aesthetic value of an area, or any threatened or endangered species, as approved by the Engineer.

If the waste disposal site(s) is located such that it is within view of any ROW, the following additional requirements shall apply:

1. Construction/demolition debris consisting of concrete, asphalt concrete, or other similar materials shall be buried in a trench completely separate from wood debris. The final cover over the construction/demolition debris shall consist of a minimum of 1 foot of soil capable of supporting vegetation. Waste disposal sites provided outside of the State ROW shall be seeded in accordance with Natural Resources Conservation Service recommendations. The seeding recommendations may be obtained through the appropriate County NRCS Office. The Contractor shall control the access to waste disposal sites not within the State ROW through the use of fences, gates, and placement of a sign or signs at the entrance to the site stating "No Dumping Allowed".
2. Concrete and asphalt concrete debris may be stockpiled within view of the ROW for a period of time not to exceed the duration of the project. Prior to project completion, the waste shall be removed from view of the ROW or buried and the waste disposal site reclaimed as noted above.

The above requirements will not apply to waste disposal sites that are covered by an individual solid waste permit as specified in SDCL 34A-6-58, SDCL 34A-6-1.13, and ARSD 74:27:10:06.

Failure to comply with the requirements stated above may result in civil penalties in accordance with South Dakota Solid Waste Law, SDCL 34A-6-1.31.

All costs associated with furnishing waste disposal site(s), disposing of waste, maintaining control of access (fence, gates, and signs), and reclamation of the waste disposal site(s) shall be incidental to the various contract items.

NOTES (CONTINUED)
FOR
C.I.P. RETAINING WALL
SALT / SAND DIVIDER
SALT / SAND STORAGE BUILDING
WIP #410D334
PCN i26q

RAPID CITY, SOUTH DAKOTA
S. D. DEPT. OF TRANSPORTATION
APRIL 2011

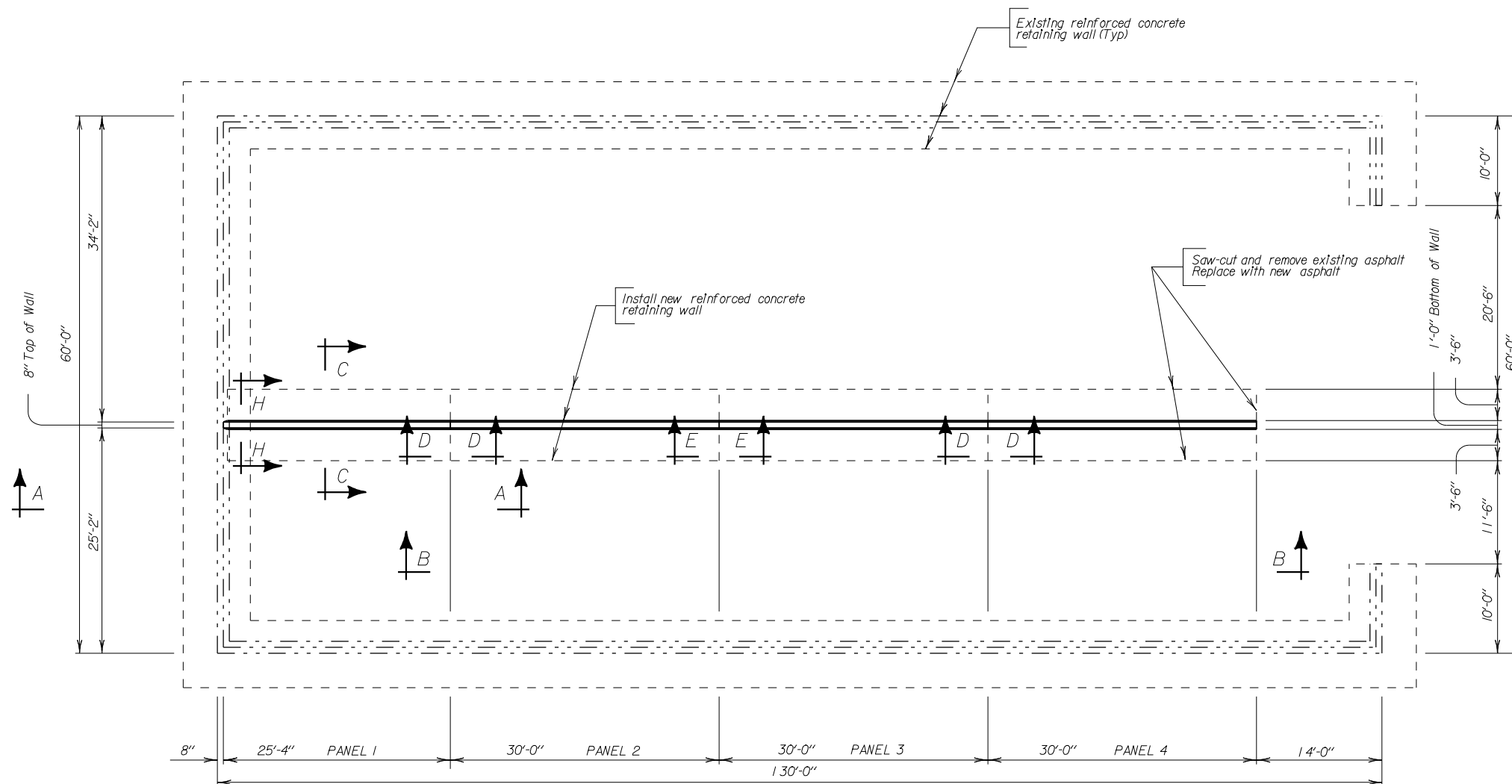

PLAN

RETAINING WALL LAYOUT
 FOR
C. I. P. RETAINING WALL
 SALT/SAND DIVIDER
 SALT/SAND STORAGE BUILDING
 WIP #410D334
 PCN 126q

RAPID CITY, SOUTH DAKOTA
 S. D. DEPT. OF TRANSPORTATION
 APRIL 2011

DESIGNED BY RS	DRAWN BY RS	CHECKED BY RS	
-------------------	----------------	------------------	--

REINFORCING SCHEDULE

	Mk.	No.	Size	Type
Panel 2	D	15	5	1'-0"
	J1	45	6	7'-6"
	J2	45	5	7'-6"
	k0	90	5	8'-0"
	kl	46	5	8'-3"
Panel 3	D	15	5	1'-0"
	J1	45	6	7'-6"
	J2	45	5	7'-6"
	k0	90	5	8'-0"
	kl	46	5	8'-3"
Panel 4	J1	45	6	7'-6"
	J2	45	5	7'-6"
	k0	90	5	8'-0"
	kl	46	5	8'-3"
	p4	38	4	29'-6"

NOTES:
 All dimensions are out to out of bars.
 All bars to be Epoxy Coated.
 ϕ D bars shall be smooth bars.

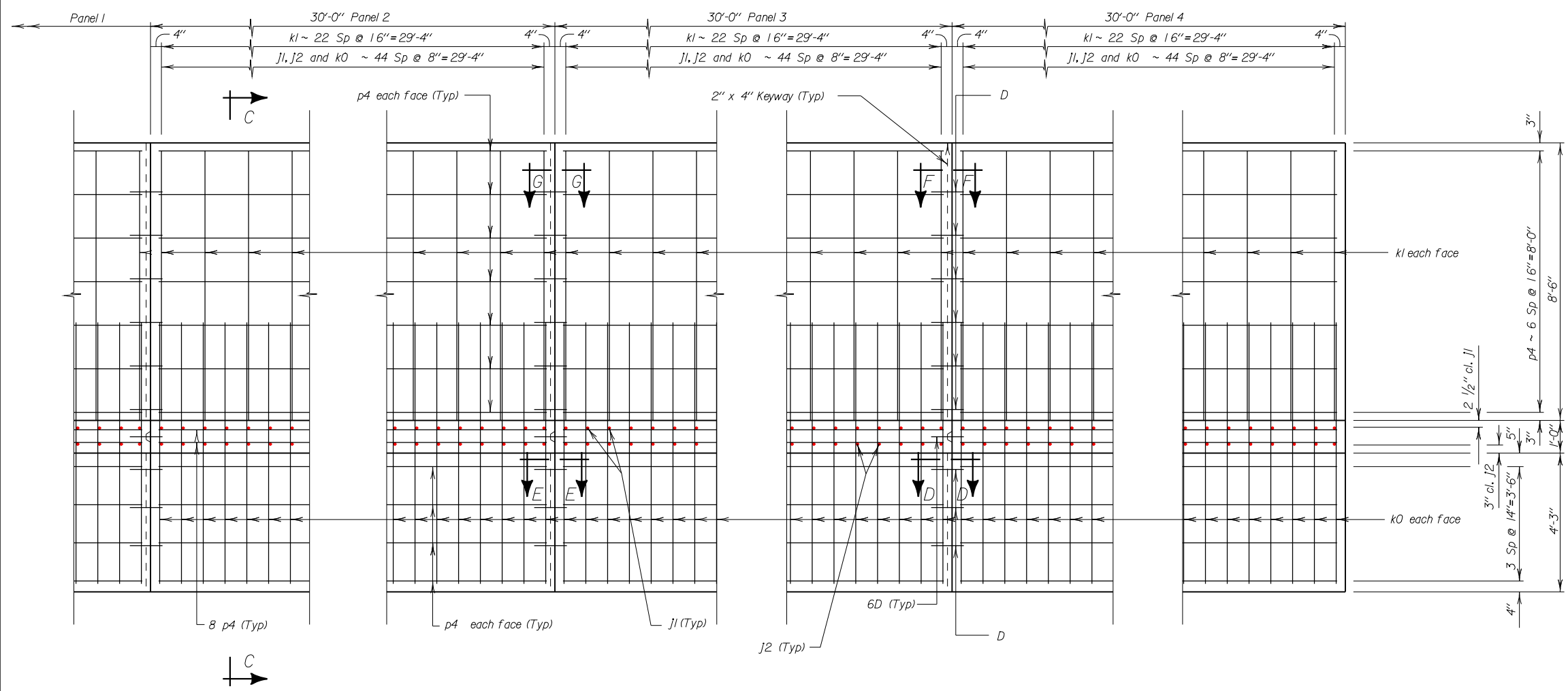

ELEVATION B-B
 (Panels 2, 3 & 4)

ESTIMATED QUANTITIES		
ITEM	Class M6 Concrete	Epoxy Coated Reinforcing
UNIT	Cu.Yd.	Lb.
Panel 2	23.1	2770
Panel 3	23.1	2770
Panel 4	23.1	2755

DETAILS FOR PANELS 2, 3 & 4
 FOR
C. I. P. RETAINING WALL
 SALT/SAND DIVIDER
 SALT/SAND STORAGE BUILDING
 WIP #410D334
 PCN 126q

RAPID CITY, SOUTH DAKOTA
 S. D. DEPT. OF TRANSPORTATION
 APRIL 2011

DESIGNED BY RS	DRAWN BY RS	CHECKED BY RS	
-------------------	----------------	------------------	--

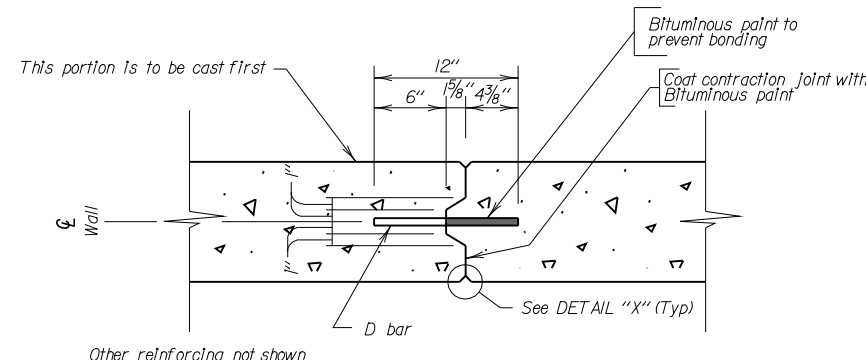
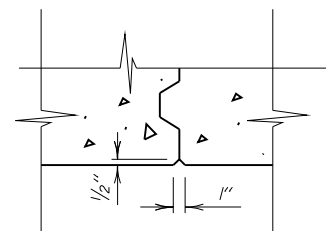
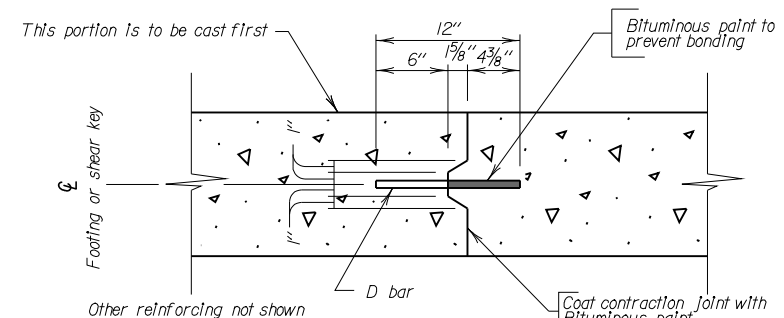
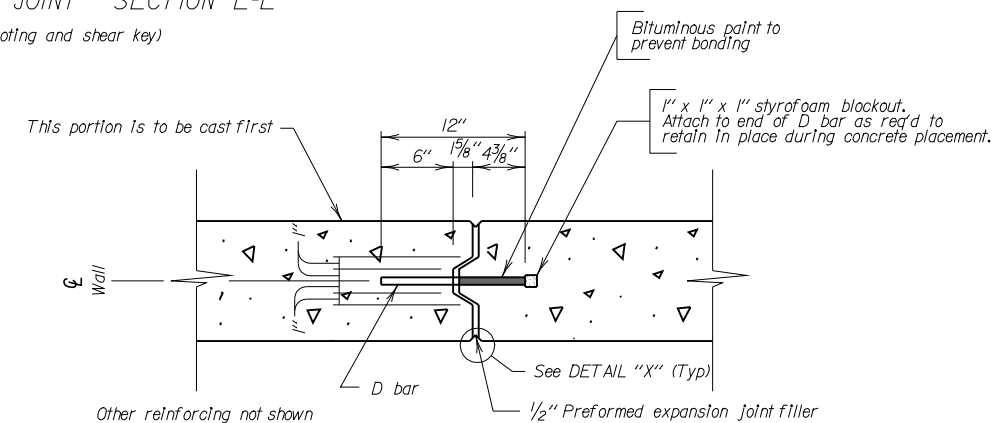
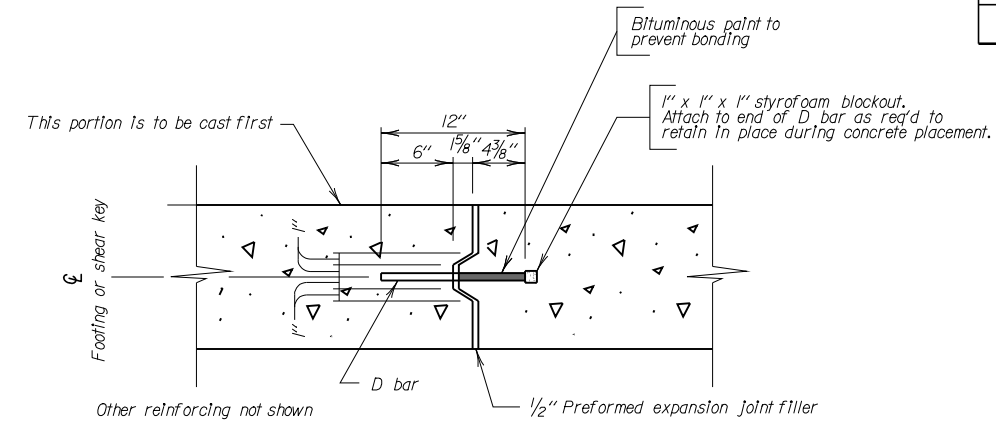
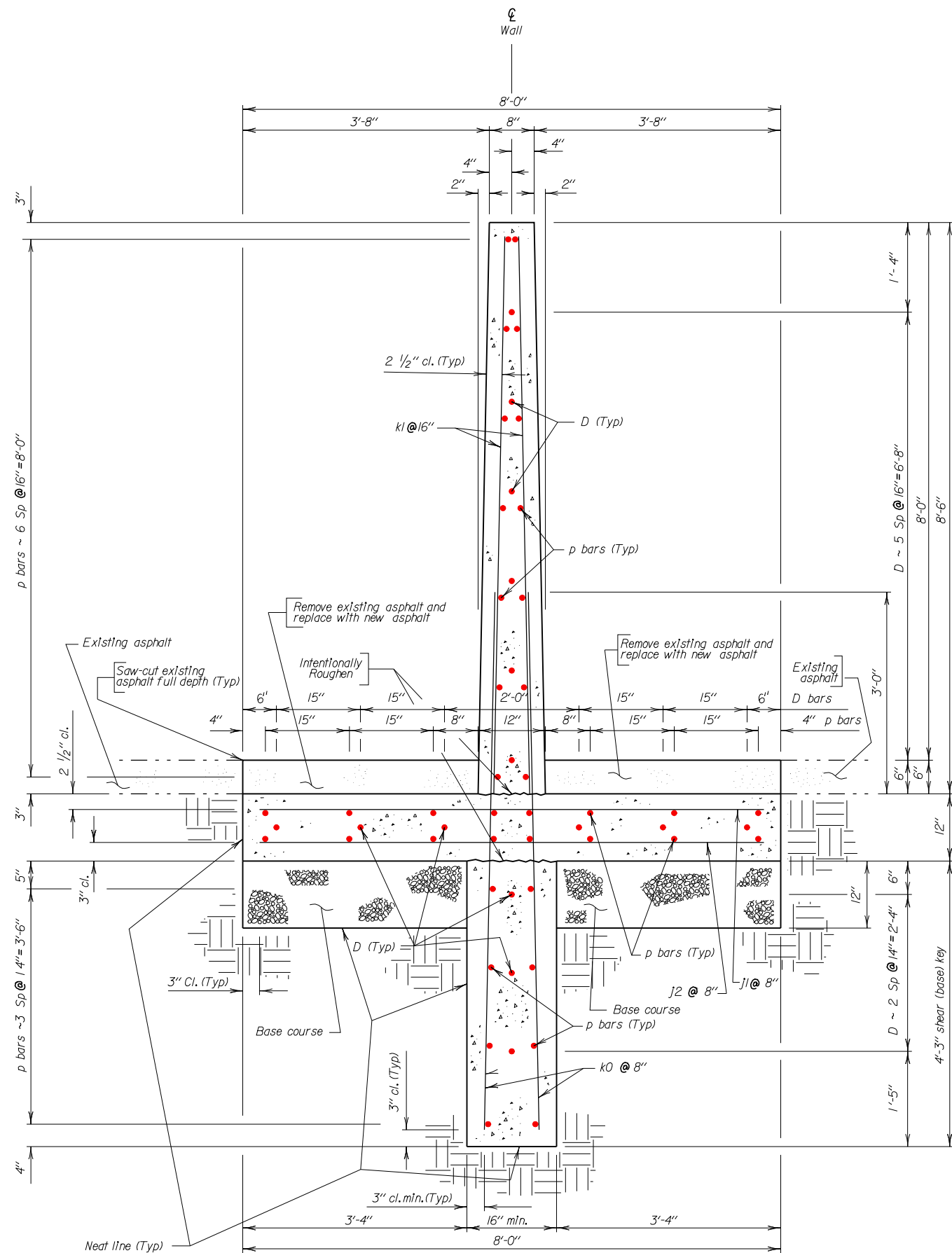

DETAILS FOR ALL PANELS FOR
C. I. P. RETAINING WALL
SALT/SAND DIVIDER
SALT/SAND STORAGE BUILDING
WIP #410D334
PCN 126q

RAPID CITY, SOUTH DAKOTA
S. D. DEPT. OF TRANSPORTATION
APRIL 2011

DESIGNED BY RS	DRAWN BY RS	CHECKED BY RS	
-------------------	----------------	------------------	--