

044-391  
Fence Replacement  
Pennington & Jackson Counties

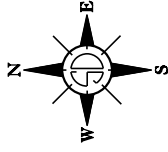

044-391  
FENCE REPLACEMENT  
PENNINGTON & JACKSON COUNTIES  
pcn i666A

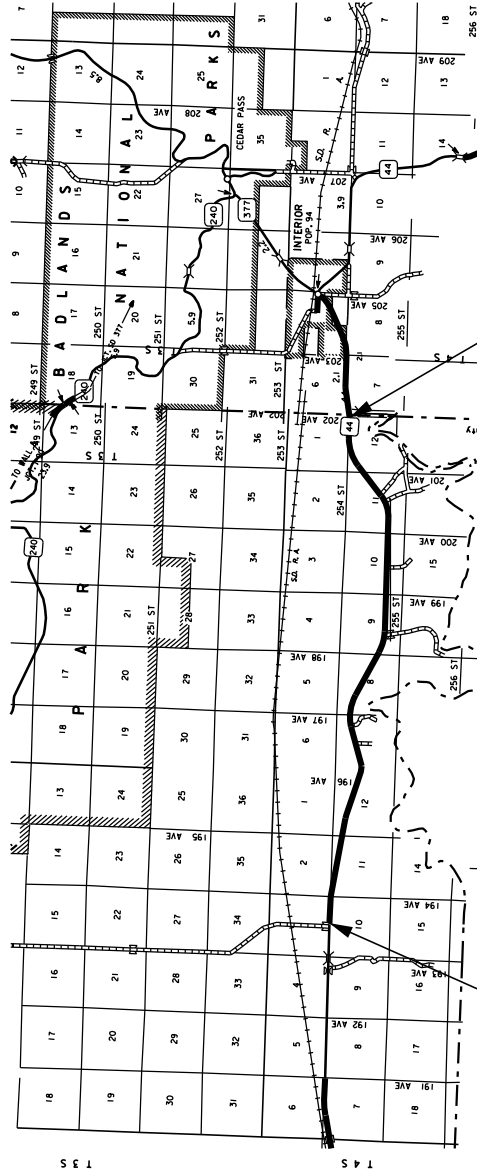

END PROJECT 044-391  
MRM 117.41

BEGIN PROJECT 044-391  
MRM 107.53

**INDEX OF SHEETS**

Sheet 1	Layout Map
Sheet 2	Index of Sheets
Sheet 3	Estimate of Quantities & Table of Fence Quantities
Sheets 4 - 8	Plan Notes
Sheets 8 to 17	Standard Plates

044-391  
Fence Replacement  
Pennington & Jackson Counties

**ESTIMATE OF QUANTITIES**

BID ITEM NUMBER	ITEM	QUANTITY	UNIT
* 009E0010	Mobilization	Lump Sum	LS
* 100E0100	Clearing	Lump Sum	LS
* 110E0600	Remove Fence	40,818	Ft
* 620E0020	Type 2 Right-of-Way Fence	40,818	Ft
* 620E1020	2 Post Panel	84	Each
* 620E1030	3 Post Panel	47	Each
* 634E0120	Traffic Control, Miscellaneous	Lump Sum	LS
* 734E0010	Erosion Control	Lump Sum	LS

\* - Denotes Non-Participating

**TABLE OF FENCE QUANTITIES**

HIGHWAY 44 Direction	MRM	to	MRM	Remove Fence FT	Type 2 Fence FT	2 Post Panels Each	3 Post Panels Each	Gates (Information Only) Each	Stream Crossings (Information Only) Each
Eastbound	107.530	to	109.000	2801	2801	3	6	2	1
Eastbound	109.000	to	109.442	2333	2333	2	4	1	0
Eastbound	112.011	to	113.000	5222	5222	9	6	3	1
Eastbound	113.000	to	113.136	718	718	3	0	2	0
Eastbound	113.465	to	114.000	3024	3024	8	4	1	1
Eastbound	114.000	to	114.149	787	787	1	1	0	0
Eastbound	115.500	to	116.000	2624	2624	4	5	2	3
Eastbound	116.000	to	116.375	1993	1993	5	2	1	1
<b>Eastbound Total =</b>				19,502.00	19,502.00	35	28	12	7
Westbound	107.530	to	109.000	2801	2801	3	1	1	1
Westbound	109.000	to	109.442	2500	2500	5	2	1	0
Westbound	112.011	to	113.000	5222	5222	9	6	3	1
Westbound	113.000	to	113.136	718	718	1	1	0	0
Westbound	113.136	to	114.000	4572	4572	17	3	2	2
Westbound	114.000	to	114.149	786	786	3	0	1	0
Westbound	115.500	to	116.000	2724	2724	6	4	1	3
Westbound	116.000	to	116.375	1993	1993	5	2	1	1
<b>Westbound Total =</b>				21,316.00	21,316.00	49	19	10	8
<b>PROJECT TOTAL =</b>				40,818.00	40,818.00	84	47	22	15

## **SPECIFICATIONS**

Standard Specifications for Roads and Bridges, 2015 Edition, and required Provisions, Supplemental Specifications and/or Special Provisions as included in the Proposal.

## **SCOPE OF WORK**

The work required for this project includes, but is not limited to, the following items, not listed in order of execution.

1. Set Up Traffic Control
2. Remove and Replace Fence
3. Restore and Seed any Disturbed Ground
4. Dispose of Debris
5. Remove Traffic Control

The Contractor is encouraged to inspect the project site prior to bidding to evaluate the extent of work that will be required for construction.

Work on the project will not be allowed to start until August 1, 2022, or as approved by the Engineer.

## **UTILITIES**

The Contractor will contact the involved utility companies through South Dakota One Call (1-800-781-7474) prior to starting work. It will be the responsibility of the Contractor to coordinate work with the utility owners to avoid damage to existing facilities.

## **WASTE DISPOSAL SITE**

The Contractor will furnish a site(s) for the disposal of construction and/or demolition debris generated by this project.

Construction and/or demolition debris may not be disposed of within the Public ROW.

The waste disposal site(s) will be managed and reclaimed in accordance with the following from the General Permit for Construction/Demolition Debris Disposal Under the South Dakota Waste Management Program issued by the Department of Environment and Natural Resources.

The waste disposal site(s) will not be located in a wetland, within 200 feet of surface water, or in an area that adversely affects wildlife, recreation, aesthetic value of an area, or any threatened or endangered species, as approved by the Environmental Office and the Project Engineer.

### **WASTE DISPOSAL SITE (Continued)**

If the waste disposal site(s) is located such that it is within view of any ROW, the following additional requirements will apply:

1. Construction and/or demolition debris consisting of concrete, asphalt concrete, or other similar materials will be buried in a trench completely separate from wood debris. The final cover over the construction and/or demolition debris will consist of a minimum of 1 foot of soil capable of supporting vegetation. Waste disposal sites provided outside of the Public ROW will be seeded in accordance with Natural Resources Conservation Service recommendations. The seeding recommendations may be obtained through the appropriate County NRCS Office. The Contractor will control the access to waste disposal sites not within the Public ROW with fences, gates, and placement of a sign or signs at the entrance to the site stating, "No Dumping Allowed".
2. Concrete and asphalt concrete debris may be stockpiled within view of the ROW for a period of time not to exceed the duration of the project. Prior to project completion, the waste shall be removed from view of the ROW or buried and the waste disposal site reclaimed as noted above.

The above requirements will not apply to waste disposal sites that are covered by an individual solid waste permit as specified in SDCL 34A-6-58, SDCL 34A-6-1.13, and ARSD 74:27:10:06.

Failure to comply with the requirements stated above may result in civil penalties in accordance with South Dakota Solid Waste Law, SDCL 34A-6-1.31.

All costs associated with furnishing waste disposal site(s), disposing of waste, maintaining control of access (fence, gates, and signs), and reclamation of the waste disposal site(s) will be incidental to the various contract items.

### **MAINTENANCE OF TRAFFIC**

All temporary traffic control sign locations will be set in the field by the Contractor and verified by the Engineer prior to installation.

All construction operations will be conducted in the general direction of traffic movement. Traffic will be maintained on the proper directional set of lanes throughout the project during construction operations. No crossing over traffic to the opposing lane be allowed. The Contractor will arrange the details of their operation as to cause a minimum of inconvenience and delay to the traveling public.

If there is a discrepancy between the traffic control plans, standard plates, and the MUTCD, whichever is more stringent will be used, as determined by the Engineer.

Unless otherwise stated in these plans, work will not be allowed during hours of darkness. During nights, weekends and other non-working hours, all non-applicable traffic control signs, materials and equipment will be removed from the roadway or ditch will be stored a minimum of 30 feet from the traveled lanes.

All costs for traffic control, including signs, will be incidental to the contract lump sum price for "Traffic Control, Miscellaneous".

### **RESTORATION OF INSLOPES AND DITCHES**

Any slope area or ditch that is rutted or otherwise unduly disturbed by the Contractors equipment during fencing operations, will be restored and seeded by the Contractor at his expense and approved by the Engineer. Cost for this work will be incidental to other contract items. The permanent seed mixture as stated elsewhere in this proposal will be used.

### **REMOVE FENCE**

As designated in the Plans and/or as ordered by the Engineer, the Contractor will remove the existing right-of-way fence that is to be replaced with a new right-of-way fence. All old fencing materials will become the property of the Contractor to dispose of.

The Contractor will be responsible to contact all landowners along the project route prior to removing fence.

Fence removed will be paid at the contract unit price per linear foot for "Remove Fence". Such payment will be full compensation for all labor, equipment and incidentals required to satisfactorily remove and dispose of the fence material

### **CONTROL OF ACCESS**

The Contractor is responsible to control access throughout the project. All fence removed during any one working day is to be replaced during the same day. If the contractor elects to use temporary fence to control access or to accommodate livestock, the cost of the temporary fence will be incidental to the contract unit prices for the various items.

### **CLEARING**

Prior to installing right-of-way fence, the fence alignment will be cleared of all trees, tree branches, tree stumps, brush, vegetation and debris.

Clearing will be paid for at the contract lump sum price for "Clearing". Payment will be full compensation for labor and equipment necessary to clear the entire line for the fence and smooth ground irregularities.

### **FENCE ALIGNMENT**

Where fence is being removed and replaced, fence will be installed on the same alignment as the existing. It will be the Contractor's responsibility to preserve the fence alignment.

## **TYPE 2 RIGHT-OF-WAY FENCE**

Type 2 Right-of-Way Fence will be installed according to Standard Plate 620.01 in the plans at locations determined by the Engineer. An estimate of quantities and location of the new right-of-way fence is given in the plans. Materials used to construct type 2 right-of-way fence will be in new condition. No salvaged materials may be used.

It's estimated that 15 locations along the project will require wide depression or stream crossing fencing as shown on Standard Plate 620.10. These locations may require existing deadmen to be reset and/or new deadmen to be installed as per section 620.5 in the Standard Specifications. All costs associated with installing and/or repairing the deadmen including materials, equipment and labor will be incidental to the contract unit price per ft for "Type 2 Right-of-Way Fence".

Type 2 Right-of-Way Fence will be measured and paid for at the contract unit price per linear foot. Payment will be full compensation for labor, equipment and all incidentals to construct the fence.

## **NEW POST PANELS**

Existing post panels will be replaced. Existing 4 Post Panels will be replaced with a combination of 2 Post Panels as determined by the Engineer.

The number of 2 Post and 3 Post Panels will be the actual number installed and will be paid for at the contract unit price per each. Payment will be full compensation for furnishing material, (including posts, brace post, diagonal brace wire, dowels), labor, equipment and incidentals necessary to construct the post panels.

## **GATES**

The Contractor will remove all existing wire gates and install new wire gates in the ROW fence. The installation of a new access gate will consist of installing a 30 ft wide wire gate as shown on Standard Plate 620.20 in the plans. Any tubular gates will be salvaged and installed after the new brace panels are in place. The materials and installation of the brace panels for the wire gates will correspond to the "New Post Panels" note and Standard Plate 620.03. Brace panels necessary to complete the gate will be paid for on a per each basis under the corresponding bid item "2-Post Panel" or "3-Post Panel".

The Contractor will be responsible to furnish all other materials necessary to construct the wire gate.

Payment for the wire gates will be incidental to the contract unit price per foot for "Type 2 Right-of-Way Fence" and will be full compensation for furnishing all materials, constructing the wire gate as shown on Standard Plate 620.20, attaching and stretching the existing wires to the brace post panel, labor, equipment and all other incidentals associated with the installation of the gates.

## **EROSION CONTROL**

The estimated area requiring erosion control is 500 square feet. In areas where the fence is adjacent to cropland and reseeding is required, the permanent seeding will extend one (1) foot beyond the fence or as directed by the Engineer. All costs for the erosion control work for furnishing, placing, and maintaining erosion control including equipment, labor, seeding and mulching will be incidental to the contract lump sum price for "Erosion Control".

The limits of erosion control work will be determined by the Engineer during construction.

### **Permanent Seeding**

Type C Permanent Seed Mixture will consist of the following:

Grass Species	Variety	Pure Live Seed (PLS) (Pounds/Acre)
Western Wheatgrass	Arriba, Flintlock, Rodan, Rosana, Walsh	16
Canada Wildrye	Mandan	2
Total:		18

Hand seeding devices approved by the Engineer will be allowed. Following the seeding operations, the area will be raked to the satisfaction of the Engineer.

### **Mulching (Grass Hay or Straw)**

The Contractor will hand mulch all disturbed areas after the completion of hand seeding. Mulch will be free of noxious weed.



044-391  
Fence Replacement  
Pennington & Jackson Counties

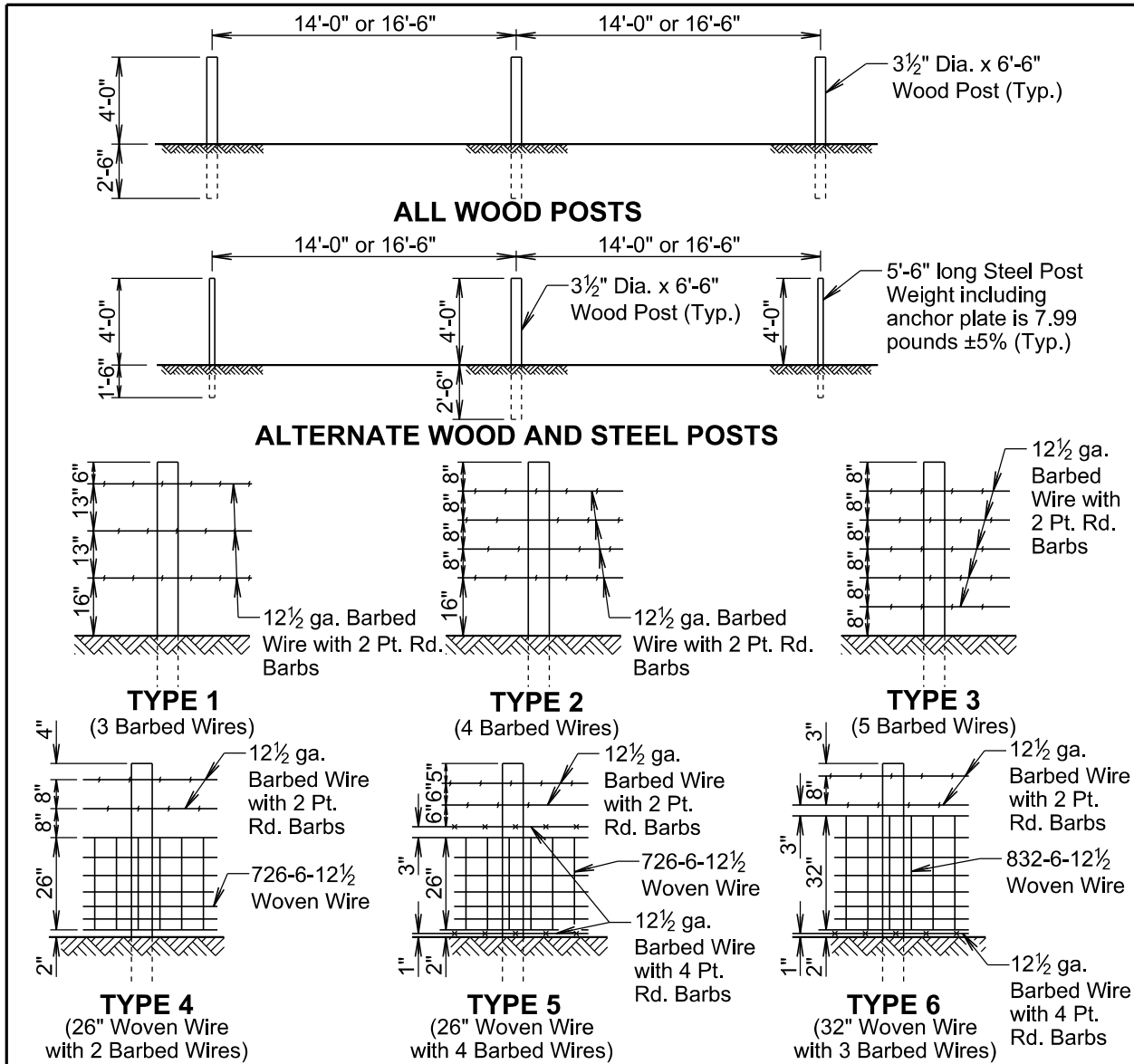

TYPE OF FENCE		LINE POST SPACING	BARBED WIRE		WOVEN WIRE
			WIRE GAGE	NUMBER AND SHAPE OF BARBS	STYLE OR DESIGN NO.
TYPE	DESCRIPTION				
1	3 Barbed Wires	16'-6"	12½	2 Point Round	—
2	4 Barbed Wires	16'-6"	12½	2 Point Round	—
3	5 Barbed Wires	16'-6"	12½	2 Point Round	—
4	26" Woven Wire with 2 Barbed Wires	14'-0"	12½	2 Point Round	726-6-12½
5	26" Woven Wire with 4 Barbed Wires	14'-0"	12½	2 wires with 2 Pt. Rd. 2 wires with 4 Pt. Rd.	726-6-12½
6	32" Woven Wire with 3 Barbed Wires	14'-0"	12½	2 wires with 2 Pt. Rd. 1 wire with 4 Pt. Rd.	832-6-12½

**GENERAL NOTES:**

Fence types designated on the plans that are followed by the letter S will have smooth (barbless) wires.

When type 5S or 6S is designated the bottom wire may be barbed, smooth, or left off.

All degrees of curvature stated for fence are at centerline of roadway.

June 26, 2019

<b>Published Date: 2nd Qtr. 2022</b>	<b>S D D O T</b>	<b>RIGHT-OF-WAY FENCE</b>	<b>PLATE NUMBER</b> <b>620.01</b> <hr/> Sheet 1 of 1
--------------------------------------	----------------------------------	---------------------------	--

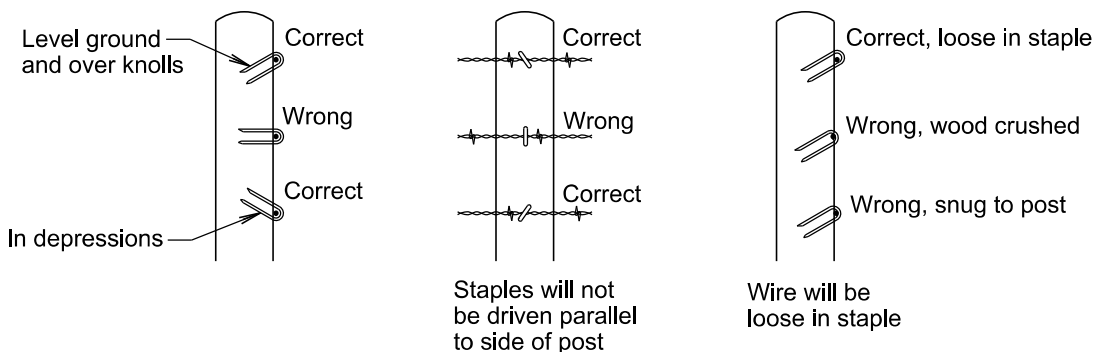

**STAPLE INSTALLATION**

**GENERAL NOTES:**

The Right-of-Way fence will consist of barbed wire or a combination of woven wire and barbed wire. The barbed wire and/or woven wire will be fastened to all wood posts or fastened to alternating wood and steel posts. Only wood posts will be used for brace panels. Gates will be of the type designated in the plans or as otherwise directed by the Engineer. Fence will be constructed conforming to the details on the standard plates and in the plans unless otherwise directed by the Engineer.

Right-of-Way fence on Interstate Projects will be constructed one foot within the Interstate Right-of-Way lines except at bridge openings, cattle passes, and as otherwise directed by the Engineer.

Right-of-Way fence other than on Interstate Projects will be constructed within one foot of the Right-of-Way on the Landowner's side except at bridge openings, cattle passes, and as otherwise directed by the Engineer.

Barbs will be fabricated from zinc coated 14 ga. wire. Two point barbs will be wrapped twice around one main strand at four-inch spacings and the four point barbs will be interlocked and wrapped around both main strands at five-inch spacings.

The gages of wire and wood post lengths and sizes are the minimum acceptable unless otherwise specified in the plans. The tolerances for steel posts will be as stated in AASHTO M281. Woven wire will conform to design and specifications of ASTM A116 and barbed wire will conform to ASTM A121.

June 26, 2019

<i>Published Date: 2nd Qtr. 2022</i>	<b>S D D O T</b>	<b>STAPLE INSTALLATION AND GENERAL RIGHT-OF-WAY FENCE NOTES</b>	<i>PLATE NUMBER</i> <b>620.02</b>
			<i>Sheet 1 of 1</i>

044-391  
 Fence Replacement  
 Pennington & Jackson Counties

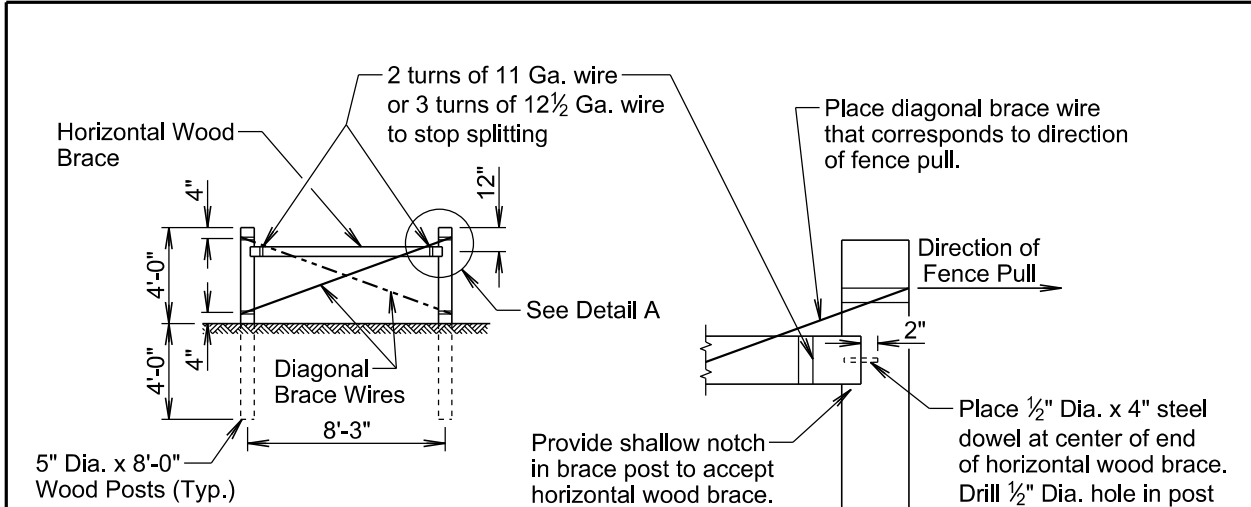

**ELEVATION VIEW**  
 (2 Post Panel)

**DETAIL A**

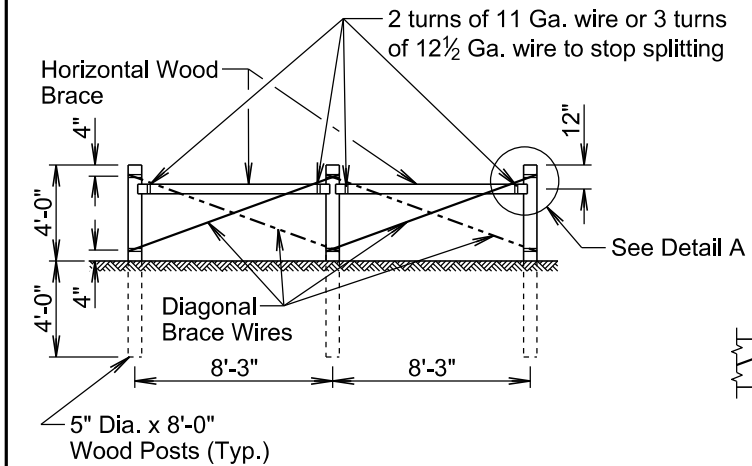

**ELEVATION VIEW**  
 (3 Post Panel)

**DETAIL B**

**GENERAL NOTES:**

- Two Post Panels will be installed at least every 1320' between corners.
- Two Post Panels will be installed at any sharp vertical angle crest points and as directed by the Engineer.
- Horizontal wood braces will consist of 4" dia. x 8' wood posts or rough 4" x 4" x 8' timbers.
- Diagonal brace wires will be fabricated with 4 strands of 9 Ga. galvanized wire twisted tight. The diagonal brace wires will be installed in accordance with the direction of the fence pull. Two diagonal brace wires are required if fence pull is in both directions.

June 26, 2019

<b>Published Date: 2nd Qtr. 2022</b>	<b>S D D O T</b>	<b>BRACE PANELS AND          APPLICATIONS OF BRACE PANELS</b>	<b>PLATE NUMBER          620.03</b>
			Sheet 1 of 3

SPACING OF 2 POST PANELS WITHIN CURVES	
DEGREE OF CURVE	SPACING OF 2 POST PANEL
less than 3°15'	** 1320'
3°15' and greater	** At P.C., P.T., and at every 1320' between P.C. and P.T.

**GENERAL NOTE:**

All degrees of curvature stated for fence are at centerline of roadway.

- \* If fence length is less than 600' to next corner use a 2 post panel.  
If fence length is greater than 600' to next corner use a 3 post panel.

- \*\* Fence lengths greater than 1320' and less than 2640' place 2 Post Panel approximately at midpoint.

① See Detail B on Sheet 1 of 3.

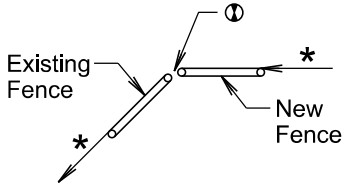

**BEGIN OR END FENCE**

(Where new fence ties into existing fence)

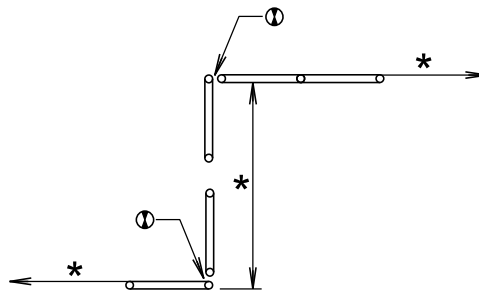
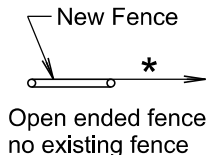

**SHORT JOGS IN FENCE**

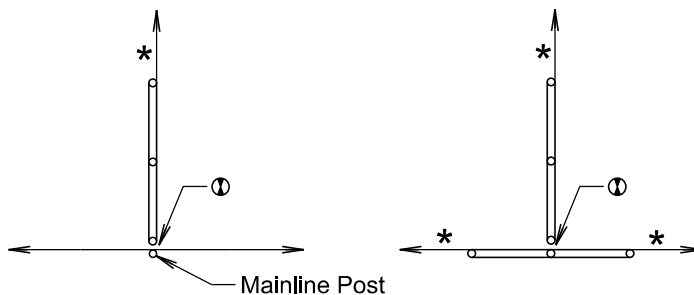

**CROSS FENCE**

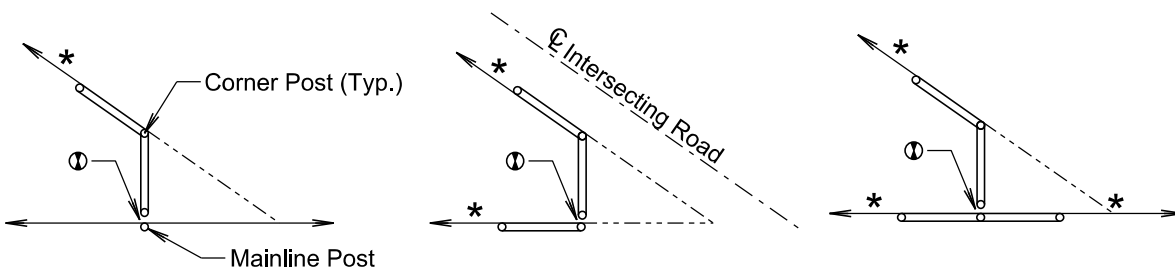

**SHARP ANGLES IN CROSS FENCE**

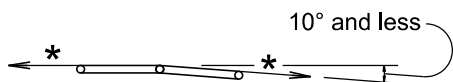

Additional fence panel is NOT required when an angle in the mainline fence is 10° and less.

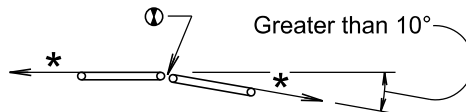

Additional fence panel is required when an angle in the mainline fence is greater than 10°.

**ANGLES IN MAINLINE FENCE**

June 26, 2019

Published Date: 2nd Qtr. 2022

**S  
D  
D  
O  
T**

**BRACE PANELS AND  
APPLICATIONS OF BRACE PANELS**

PLATE NUMBER  
620.03

Sheet 2 of 3

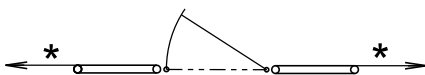

**ENTRANCE**  
 (Not on corner)

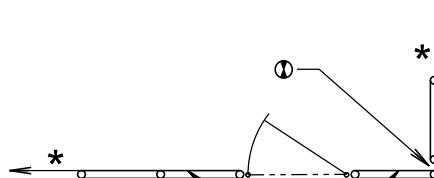
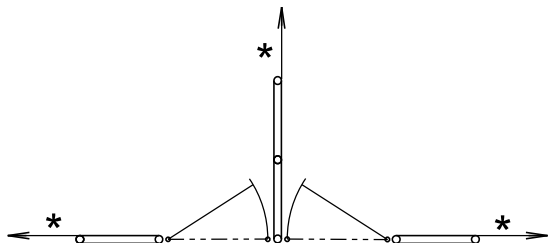

Fence type will be same as adjacent fence type or as directed by the Engineer.

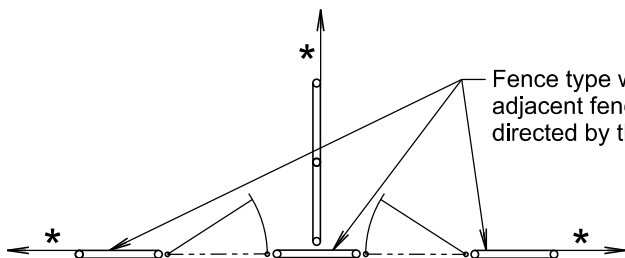
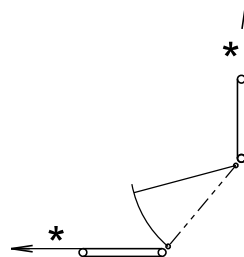
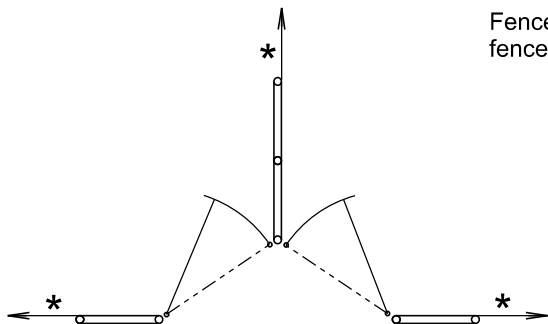

Fence type will be same as adjacent fence type or as directed by the Engineer.

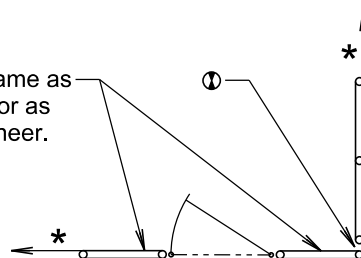

**DOUBLE ENTRANCES**

**ENTRANCES AT CORNERS**

**GATES**

- \* If fence length is less than 600' to next corner use a 2 post panel.
- \* If fence length is greater than 600' to next corner use a 3 post panel.

① See Detail B on Sheet 1 of 3.

June 26, 2019

Published Date: 2nd Qtr. 2022

**S  
D  
D  
O  
T**

**BRACE PANELS AND  
 APPLICATIONS OF BRACE PANELS**

PLATE NUMBER  
**620.03**

Sheet 3 of 3

044-391  
 Fence Replacement  
 Pennington & Jackson Counties

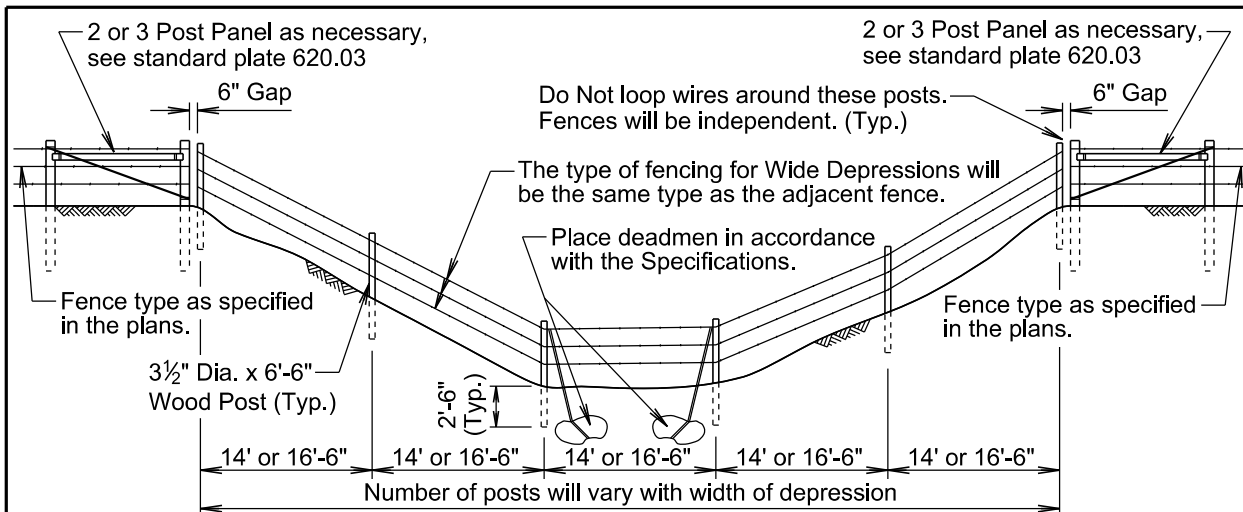

This installation will be made when requested by the Engineer.  
**FENCING AT WIDE DEPRESSION**  
 (Subject to Flooding)

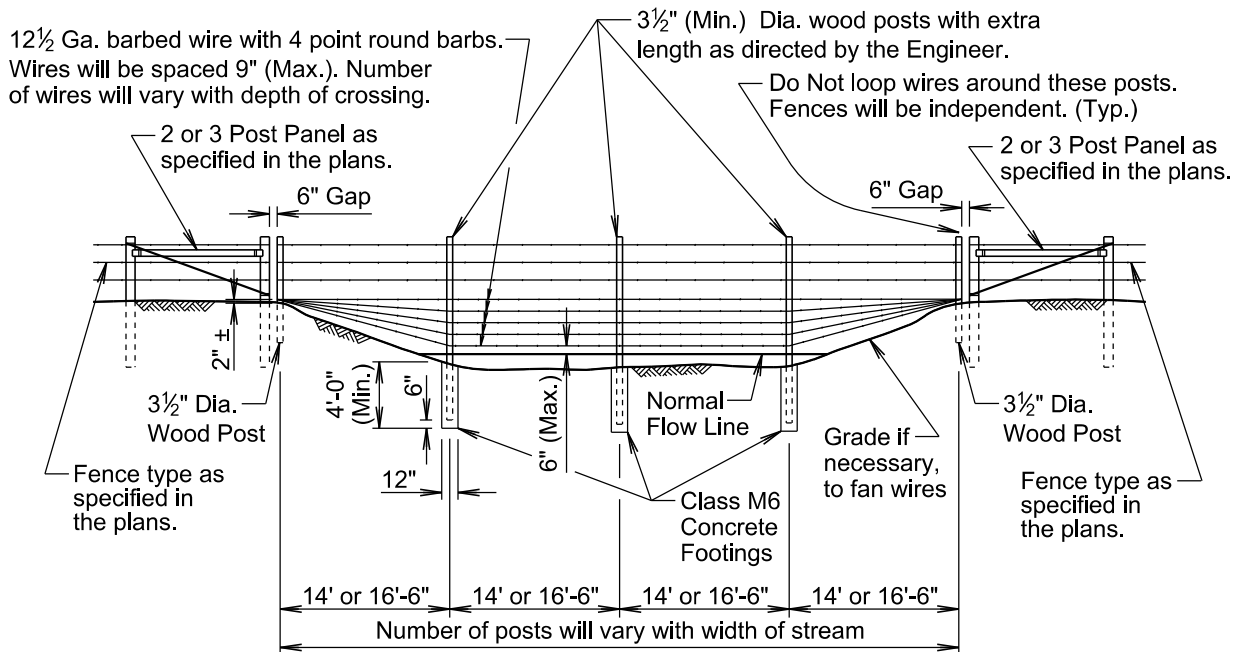

This installation will be made only when stated in the plans.  
**FENCING AT STREAM CROSSING**

**GENERAL NOTES:**

There will be no extra payment for the additional work and materials required to construct the fencing at the wide depression(s) and/or the fencing at the stream crossing(s). The deadmen will be paid for in accordance with 620.5 A of the Specifications.

Measurement and payment for the fencing at the wide depression(s) and/or the fencing at the stream crossing(s) will be at the contract unit price per foot for the corresponding Right-of-Way fence contract item.

June 26, 2019

<i>Published Date: 2nd Qtr. 2022</i>	<b>S D D O T</b>	<b>FENCING AT WIDE DEPRESSION(S) AND STREAM CROSSING(S)</b>	PLATE NUMBER <b>620.10</b>
			Sheet 1 of 1

044-391  
Fence Replacement  
Pennington & Jackson Counties

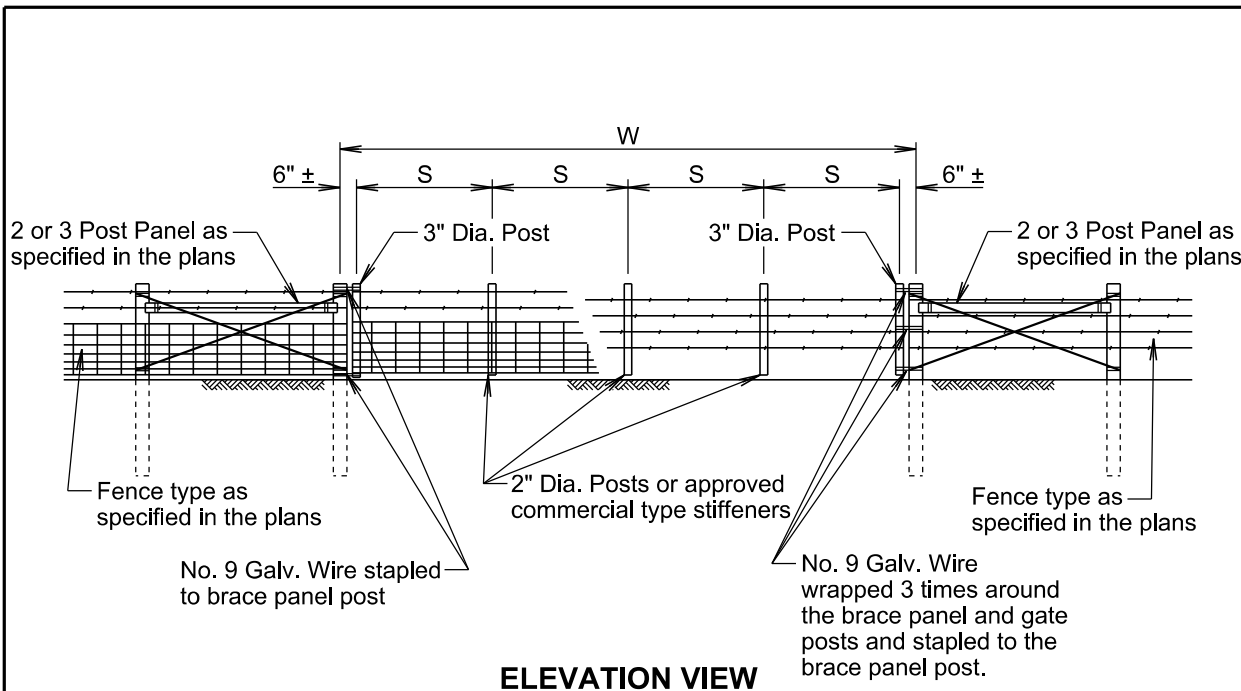

W Gate Width (Ft.)	S Post Spacing
16	3 @ 5'-0" ±
20	4 @ 4'-9" ±
24	4 @ 5'-9" ±
30	5 @ 5'-10" ±
40	6 @ 6'-6" ±

**GENERAL NOTES:**

Creosote treatment of the gate posts will not be accepted.

The type of fencing in the gate will be of the same type as specified for the adjacent Right-of-Way fence.

All costs for furnishing and constructing the wire gate(s) will be incidental to the contract unit price per foot for the respective Right-of-Way fence contract item.

June 26, 2019

<i>Published Date: 2nd Qtr. 2022</i>	<b>S D D O T</b>	<b>WIRE GATES</b>	<i>PLATE NUMBER</i> <b>620.20</b>
			<i>Sheet 1 of 1</i>

044-391  
Fence Replacement  
Pennington & Jackson Counties

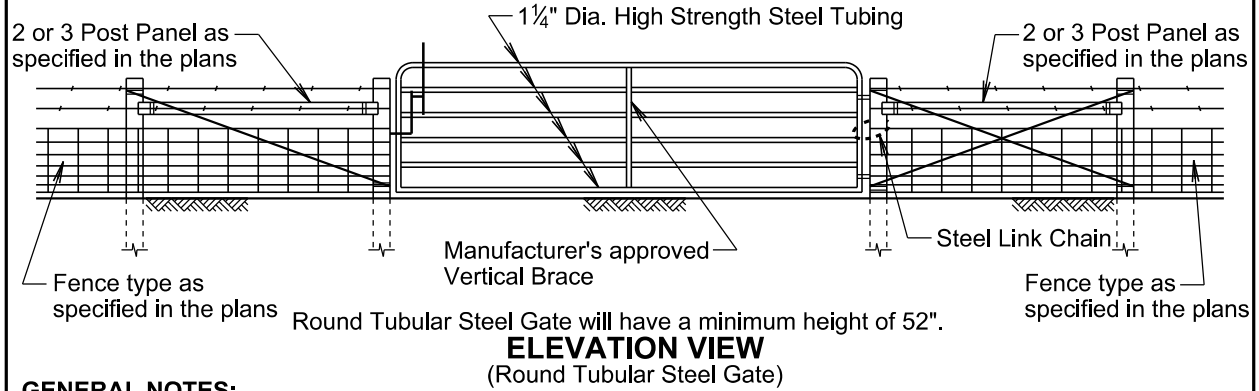
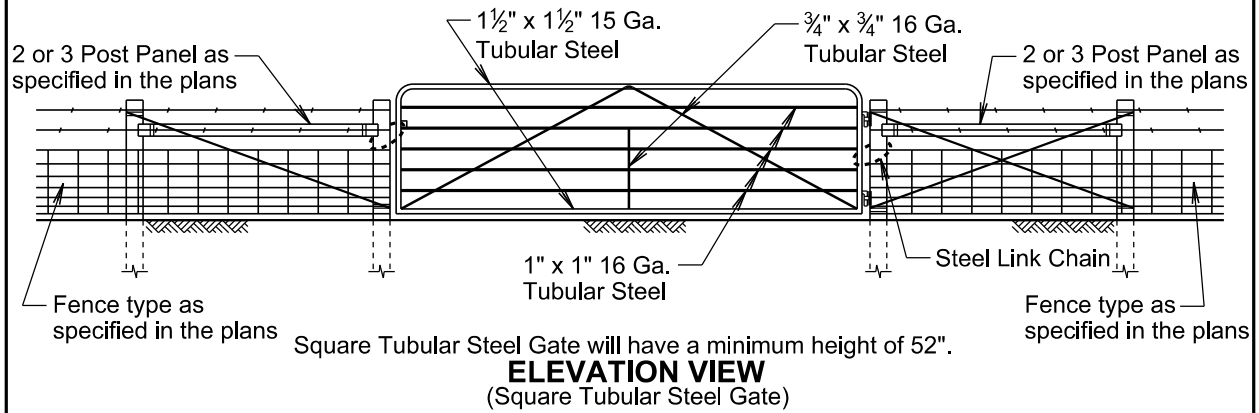
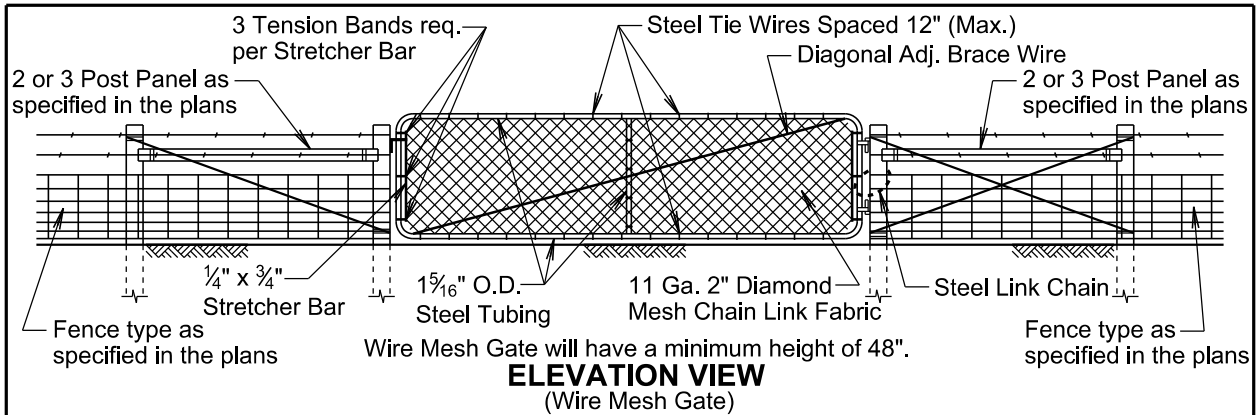

**GENERAL NOTES:**

Only single tubular frame gates are shown on this standard plate. If double tubular frame gates are specified, the gates will be of the same type and materials as shown above. Double tubular gates will swing toward the middle of the opening and will be secured by a chain, latch, or other suitable hardware.

Gate hardware will conform to the specific type of gate installed. The gate and gate hardware will either be painted or galvanized. The paint on the gates and hardware will be subject to approval by the Engineer.

The Steel Link Chain will be a minimum of 1/4", 4' long, rust resistant, and have electrically welded links. The chain will be wrapped around the gate hinge post and gate frame and the ends of the chain will be welded together with enough slack in the chain to provide free operation of the gate.

June 26, 2019

<i>Published Date: 2nd Qtr. 2022</i>	<b>S D D O T</b>	<b>TUBULAR FRAME GATES</b>	<b>PLATE NUMBER</b> <b>620.21</b>
			Sheet 1 of 1



044-391  
 Fence Replacement  
 Pennington & Jackson Counties

The signs illustrated are not required if the work space is behind a barrier, more than 2 feet behind the curb, or 15 feet or more from the edge of any roadway.

The signs illustrated will be used where there are distracting situations; such as: vehicles parked on shoulder, vehicles accessing the work site via the highway, and equipment traveling on or crossing the roadway to perform work operations.

The ROAD WORK AHEAD sign may be replaced with other appropriate signs, such as the SHOULDER WORK sign. The SHOULDER WORK sign may be used for work adjacent to the shoulder.

\* If the work space is on a divided highway, an advance warning sign should also be placed on the left side of the directional roadway.

For short term, short duration, or mobile operations, all signs and channelizing devices may be eliminated if a vehicle with an activated flashing or revolving yellow light is used.

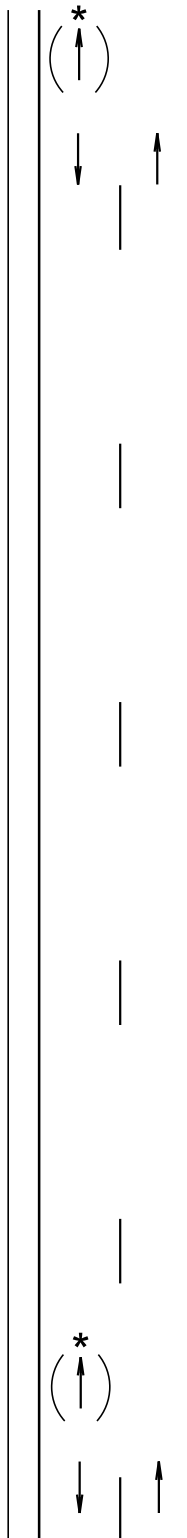

Posted Speed Prior to Work (M.P.H.)	Spacing of Advance Warning Signs (Feet) (A)
0 - 30	200
35 - 40	350
45 - 50	500
55	750
60 - 80	1000

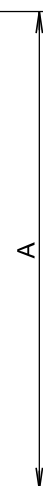

January 22, 2021

<i>Published Date: 2nd Qtr. 2022</i>	<b>S D D O T</b>	<b>WORK BEYOND THE SHOULDER</b>	PLATE NUMBER <b>634.01</b>
			Sheet 1 of 1